

TTL DATA BOOK

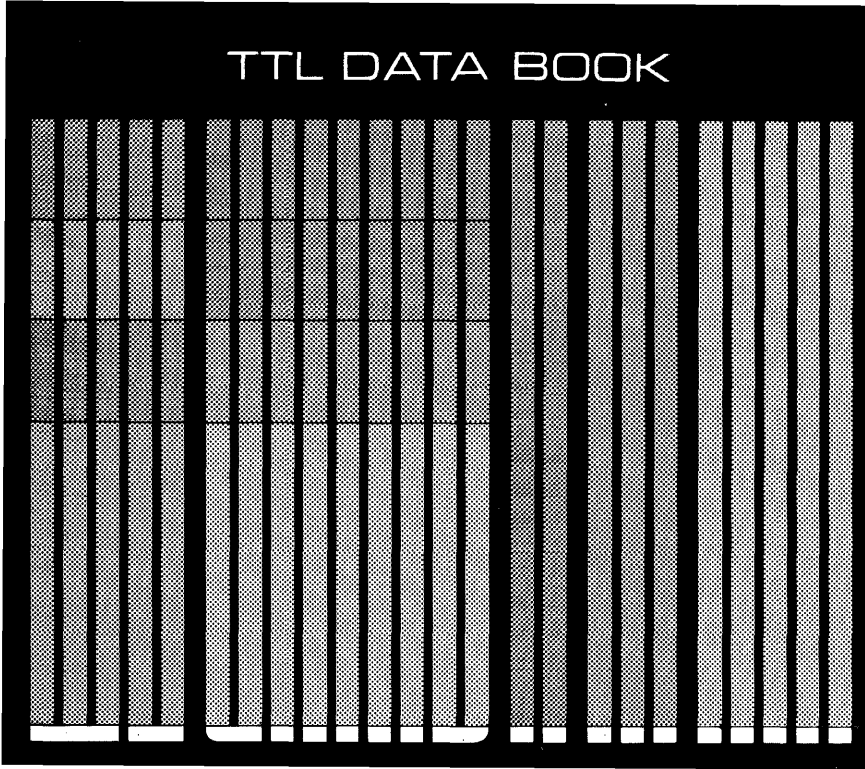

MADE IN
FAIRCHILD

**Fairchild
Semiconductor
TTL Data Book
Contents And
Section Selector**

If you know the correct 5400, 7400, 9300 or 9600 device type number, find the correct page in the Numerical Index.

General and Order Information

1

Numerical Index

2

Selector Guide and Functional Index

3

If you are trying to choose the best device for your application, consult the Selector guides.

TTL Loading Rules

4

SSI
9000, 9H(54H/74H), 9L, 9N(54/74)
and 9S(54S/74S) Series Data Sheets

5

SSI
Switching and dc Test Circuits

6

If you need the package dimensions for a specific device, see Packaging Information.

SSI
Monostable Multivibrator and Interface
Circuits 9600 Series Data Sheets

7

MSI
9300, 93L, 93S and 54/74
Series Data Sheets

8

Memory - 93400 Data Sheets

9

If you need the exact, or nearest Fairchild equivalent to another manufacturer's device, consult the Cross Reference Guide.

Packaging Information

10

Industry Cross Reference Guide

11

Other Fairchild Digital Families
and Application Notes

12

The Fairchild Semiconductor TTL Data Book

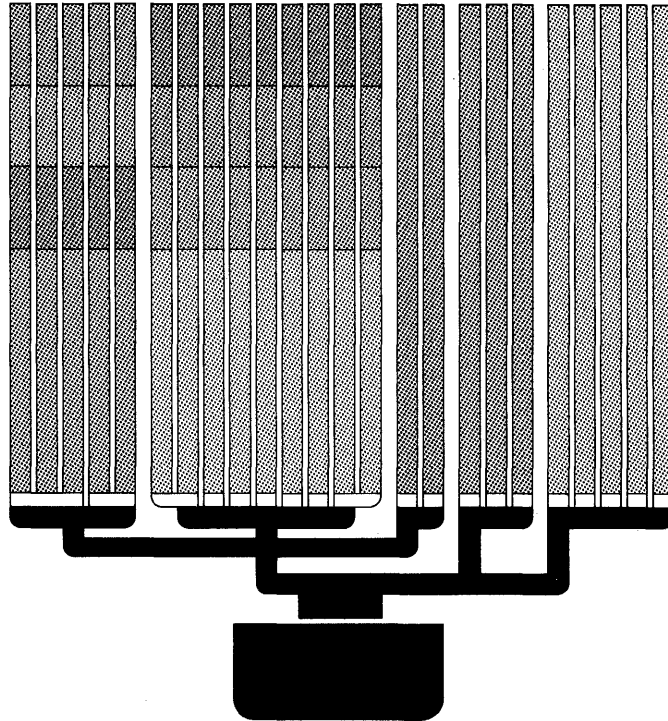

The TTL Family

Fairchild's TTL Family is the most complete line of TTL products available today. There are over 250 circuit functions with more than 100 MSI devices from which to choose. The family consists of logic, memory and interface functions, and is a unique blend of Fairchild proprietary circuits and a large number of second source devices which have achieved wide market acceptance.

Fairchild's family of functions has been designed to provide the system designer with a complete line of standard off-the-shelf functional building blocks that can be interfaced directly with each other in the same system to provide the optimum Speed/Power combination.

9000	Medium Speed SSI
9H00	High Speed SSI
9L00	Low Power SSI
9N00	Standard SSI
9S00	Schottky SSI
9300	Standard MSI
93L00	Low Power MSI
93S00	Schottky MSI
9600	Monostable SSI
93400	Memory Elements

Fairchild Semiconductor
464 Ellis Street
Mountain View, California 94040

FAIRCHILD SALES OFFICES

HUNTSVILLE, ALABAMA
3322 So. Memorial Parkway 35801
Suite 92
Tel: 205-883-7020 TWX: 810-726-2214

PHOENIX, ARIZONA
301 West Indian School Rd. 85013
Suite 103
Tel: 602-264-4948 TWX: 910-951-1544

LOS ALTOS, CALIFORNIA
Village Corner, Suite L
El Camino and San Antonio Rds. 94022
Tel: 415-941-3150 TWX: 910-370-7952

LOS ANGELES, CALIFORNIA
6922 Hollywood Blvd. 90028
Suite 818
Tel: 213-466-8393 TWX: 910-321-3009

SANTA ANA, CALIFORNIA
2100 East 4th Street 92705
Suite 207
Tel: 714-558-1881 TWX: 910-595-1109

SAN DIEGO, CALIFORNIA
8865 Balboa Ave. 92123
Suite H
Tel: 714-279-6021

DENVER, COLORADO
5115 South Valley Highway
Greenwood Gardens, Suite 240
Englewood, Colo. 80110
Tel: 303-770-2884 TWX: 910-935-0708

STAMFORD, CONNECTICUT
36 Turn of River Road 06905
Tel: 203-329-8106 TWX: 710-474-1763

FT. LAUDERDALE, FLORIDA
3440 N.E. 12th Avenue 33308
Room 2
Tel: 305-566-7414 TWX: 510-955-9840

ORLANDO, FLORIDA
211 N. Maitland Avenue
Suite 307
Altamonte Springs, Florida 32701
Tel: 305-834-7000 TWX: 810-850-0152

CHICAGO, ILLINOIS
9950 W. Lawrence Avenue
Room 311
Schiller Park, Ill. 60176
Tel: 312-671-4660 TWX: 910-227-0051

INDIANAPOLIS, INDIANA
4002 Meadows Drive 46205
Suite 216
Tel: 317-542-0641 TWX: 810-341-3432

FORT WAYNE, INDIANA
2118 Inwood Drive 46805
Suite 111
Tel: 219-483-6453 TWX: 810-332-1507

BLADENSBURG, MARYLAND
5809 Annapolis Road 20710
Suite 408
Tel: 301-779-0954 TWX: 710-826-9654

BOSTON, MASSACHUSETTS
167 Worcester Street
Wellesley Hills, Mass. 02181
Tel: 617-237-3400 TWX: 710-348-0424

DETROIT, MICHIGAN
Westland Office Plaza
33 300 Warren Avenue Suite 101
Westland, Mich. 48185
Tel: 313-425-3250 TWX: 810-242-2973

MINNEAPOLIS, MINNESOTA
4640 W. 77th Street 55435
Suite 347
Tel: 612-920-1030 TWX: 910-576-2944

ST. LOUIS, MISSOURI
400 Brookes Lane
Hazelwood, Missouri 63042
Tel: 314-731-1161 TWX: 910-762-0603

WAYNE, NEW JERSEY
1200 Preakness Ave. 07470
Tel: 201-696-7070

ALBUQUERQUE, NEW MEXICO
First National Bank, Bldg. E, Suite 1213
5301 Central N.E. 87108
Tel: 505-265-5601 TWX: 910-989-1186

MELVILLE, NEW YORK
275 Broadhollow Road 11746
Tel: 516-293-2900 TWX: 510-224-6480

WAPPINGERS FALLS, NEW YORK
120 E. Main Street (Rt. 9) 12590
Tel: 914-297-4351 TWX: 510-248-7686

SYRACUSE, NEW YORK
333 E. Onondaga Street 13202
Tel: 315-472-3391 TWX: 710-541-0499

CLEVELAND, OHIO
6151 Wilson Mills Rd.
Suite 102
Highland Heights, Ohio 44143
Tel: 216-461-8288

DAYTON, OHIO
4812 Frederick Road 45414
Suite 101
Tel: 513-278-8278 TWX: 810-459-1803

FT. WASHINGTON, PENNSYLVANIA
Ft. Washington Industrial Park
1000 Center 19034
Tel: 215-886-6623 TWX: 510-665-1654

DALLAS, TEXAS
725 So. Central Expressway
Suite B-6
Richardson, Texas 75080
Tel: 214-234-3391 TWX: 910-867-4757

HOUSTON, TEXAS
6440 Hillcroft 77036
Suite 507
Tel: 713-772-0200

SEATTLE, WASHINGTON
700 108th Avenue Northeast
Suite 211
Bellevue, Washington 98004
Tel: 206-454-4946 TWX: 910-443-2318

INTERNATIONAL FIELD SALES OFFICES

AUSTRALIA
Fairchild Australia Pty. Ltd.
420 Mt. Dandenong Road
P.O. Box 151
Croydon, Victoria
Tel: 723-4131 Telex: 79030846

BRAZIL
Fairchild Electronica Ltd.
Caixa Postal 30.407
Sao Paulo S.P., Brazil
Tel: 33-5891
33-2765
TWX: NBR 021-261

CANADA
Toronto Regional Office
FSC
17 Canso Road, Unit 6
Rexdale, Ontario
Tel: 416-248-0285 TWX: 610-492-2700

FRANCE
Fairchild Semiconducteurs, S.A.
11, Rue Sainte Felicite
75 Paris 15,
Tel: 824-8494 Telex: 842-20614

HOLLAND
Fairchild Semiconductor
Wal 11
Eindhoven, Holland
Tel: 0314067727 Telex: 044 51024

HONG KONG
Semiconductor, Ltd.
135 Hoi Bun Road
P.O. Box 9575
Kwun Tong, Kowloon
Tel: 89 0271 Telex: 780-3531

ITALY
Fairchild Semiconductori, S.p.A.
Via F. Lampertico 7
00191 Roma
Tel: 32 78 434
Fairchild Semiconductori, S.p.A.
Via Palmanova 67 - II B
20132 Milan
Tel: 2899248 Telex: 043 34338

GERMANY
Fairchild Halbleiter GmbH
European Headquarters
6202 Wiesbaden Biebrich
Postfach 4559
Hagenauer Strasse 38
Tel: 06121/2051 TWX: 041-86588
Fairchild Halbleiter GmbH
Bayerstr. 15
8000 Munchen 2
Tel: 0811/593632 Telex: 0524831

Fairchild Halbleiter GmbH
Königswoerther Str. 23
3000 Hannover
Tel: (0511) 1 78 44 Telex: 092-2922

GERMANY (cont.)
Fairchild Halbleiter GmbH
Parler Strasse 65
7000 Stuttgart-Nord
Tel: (0711) 22 35 75 Telex: 072-2644

JAPAN
TDK-Fairchild
Sanyo Kokusaku Bldg. 2nd Fl.
7-8 Shiguya 1-Chrome
Shibuya-KU, Tokyo, Japan
Tel: (03) 400-8351 TWX: 2424173

MEXICO
Fairchild Mexicana S/A
Blvd. Presidente Adolfo Lopez Mateos 163
Col. Mexcoac, Mexico 19, D.F.
Tel: 563 5411 Telex: 0071-71-038

SWEDEN
Fairchild Semiconductor AB
Svartensgatan 6,
S-11620 Stockholm
Tel: 08-449255 Telex: 17759

UNITED KINGDOM
Fairchild Semiconductor Ltd.
Kingmaker House, Station Road
New Barnet, Herts EN5 1NX
Tel: 0441/4407311 Telex: 051-262 835

ORDER INFORMATION

A simplified ordering procedure for Fairchild digital integrated circuits is introduced with the publication of this catalog. Three basic units of information are contained in the new order code:

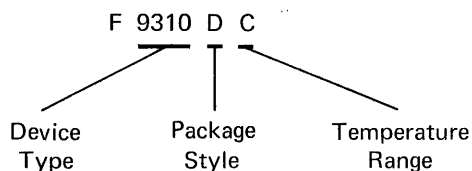

Device Type

Four to seven alpha numeric characters define the device functional and electrical characteristics, as specified in the data sheets.

Package Style

One letter represents the basic package style.

- D = Dual In-Line Ceramic (Hermetic)
- E = Plastic Can
- F = Flat Package (Hermetic)
- H = Metal Can
- P = Dual In-Line Plastic

Different outlines exist within each package style to accommodate the various die sizes and numbers of leads. Specific dimensions for each package can be found in the "Packaging Information" section.

Temperature Range

Two Basic temperature grades are in common use:

- C = Commercial-Industrial, 0°C to +70°C (or 75°C)
- M = Military, -55°C to +125°C

Exact values and conditions are indicated on the data sheets.

Examples

- (a) 93L28FM
This number code indicates a 93L28 register in a flat package with military temperature rating capability.
- (b) 9317BDC
This number code indicates a 9317 decoder/driver with B voltage option in a ceramic dual in-line package with commercial temperature rating.

Device Identification/Marking

All Fairchild standard catalog digital circuits will be marked as follows:

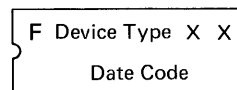

When more than one number is in common use for a device, slash marking with both numbers may be used. Example: 74H04/9H04.

Mil Spec 38510 Processing

Additional processing to Fairchild Unique 38510 specifications is indicated by noting the appropriate requirements after the standard order code.

Detailed ordering procedures are provided in the OEM price list.

Old Order Codes

Devices may continue to be purchased against old order codes (Example: U7B931059X). However, all products will be marked with new order codes unless otherwise specified.

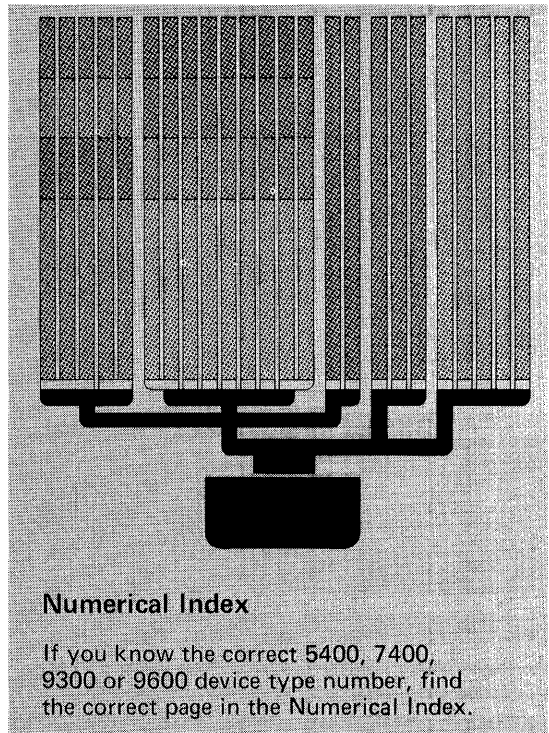

- 2
- 3
- 4
- 5
- 6
- 7
- 8
- 9
- 10
- 11
- 12

NUMERICAL INDEX OF DEVICES

DEVICE	DESCRIPTION	PAGE	DEVICE	DESCRIPTION	PAGE
4100	See 93400	9-1	54H30 (9H30)	Single 8-Input NAND Gate	5-69
4101	See 93401	9-27	5432 (9N32)	Quad 2-Input OR Gate	5-71
4102	See 93402	9-6	5437 (9N37)	Quad 2-Input NAND Gate/Buffer	5-72
4103	See 93403	9-10	5438 (9N38)	Quad 2-Input NAND Gate/Buffer (Open Collector)	5-72
4106	See 93406	9-13	5439 (9N39)	Quad 2-Input NAND Gate/Buffer (Open Collector)	5-74
5033	See 93407	9-23	5440 (9N40)	Dual 4-Input NAND Buffer	5-76
5400 (9N00)	Quad 2-Input NAND Gate	5-28	54H40 (9H40)	Dual 4-Input NAND Buffer	5-75
54H00 (9H00)	Quad 2-Input NAND Gate	5-25	54S40 (9S40)	Dual 4-Input NAND Buffer	5-77
54S00 (9S00)	Quad 2-Input NAND Gate	5-29	5442 (9352)	BCD to Decimal Decoder/Driver	8-183
5401 (9N01)	Quad 2-Input NAND Gate (Open Collector)	5-31	5443 (9353)	Excess-3 to Decimal Decoder	8-183
54H01 (9H01)	Quad 2-Input NAND Gate (Open Collector)	5-30	5444 (9354)	Excess-3 Gray to Decimal Decoder	8-183
5402 (9N02)	Quad 2-Input NOR Gate	5-32	5445 (9345)	1-of-10 Decoder	8-173
5403 (9N03)	Quad 2-Input NAND Gate (Open Collector)	5-33	5446 (9357A)	BCD to 7-Segment Decoder/Driver	8-191
* 54S03 (9S03)	Quad 2-Input NAND Gate (Open Collector)	5-34	5447 (9357B)	BCD to 7-Segment Decoder/Driver	8-191
5404 (9N04)	Hex Inverter	5-38	5448 (9358)	BCD to 7-Segment Decoder	8-197
54H04 (9H04)	Hex Inverter	5-35	5449 (9359)	BCD to 7-Segment Decoder	8-197
54S04 (9S04)	Hex Inverter	5-39	5450 (9N50)	Dual AND/OR Gate Inverter/Expander	5-80
5405 (9N05)	Hex Inverter (Open Collector)	5-41	54H50 (9H50)	Dual AND/OR Gate Inverter/Expander	5-78
54H05 (9H05)	Hex Inverter (Open Collector)	5-40	5451 (9N51)	Dual 2-Input AND/OR Invert Gate	5-80
* 54S05 (9S05)	Hex Inverter (Open Collector)	5-42	54H51 (9H51)	Dual 2-Input AND/OR Invert Gate	5-78
5406 (9N06)	Hex Inverter Buffer/Driver	5-43	54H52 (9H52)	2-2-2-3-Input AND/OR Gate	5-82
5407 (9N07)	Hex Buffer/Driver	5-44	5453 (9N53)	Expandable 4 Wide 2-Input AND/OR Invert Gate	5-86
5408 (9N08)	Quad 2-Input AND Gate	5-46	54H53 (9H53)	Expandable 2-2-2-3-Input AND/OR Invert Gate	5-84
54H08 (9H08)	Quad 2-Input AND Gate	5-45	5454 (9N54)	4 Wide 2-Input AND/OR Invert Gate	5-86
5409 (9N09)	Quad 2-Input AND Gate (Open Collector)	5-47	54H54 (9H54)	2-2-2-3-Input AND/OR Invert Gate	5-84
5410 (9N10)	Triple 3-Input NAND Gate	5-49	54H55 (9H55)	2 Wide 4-Input AND/OR Invert Gate	5-90
54H10 (9H10)	Triple 3-Input NAND Gate	5-48	5460 (9N60)	Dual 4-Input Expander	5-93
5411 (9N11)	Triple 3-Input AND Gate	5-51	54H60 (9H60)	Dual 4-Input Expander	5-92
54H11 (9H11)	Triple 3-Input AND Gate	5-50	54H61 (9H61)	Triple 3-Input Expander	5-94
5412 (9N12)	Triple 3-Input NAND Gate (Open Collector)	5-52	54H62 (9H62)	3-2-2-3-Input AND/OR Expander	5-95
5413 (9N13)	Dual 4-Input NAND Schmitt Trigger	5-53	54S64 (9S64)	4-2-3-2-Input AND/OR Invert Gate	5-96
5416 (9N16)	Hex Inverter Buffer/Driver	5-43	* 54S65 (9S65)	4-2-3-2-Input AND/OR Invert Gate (Open Collector)	5-97
5417 (9N17)	Hex Buffer/Driver	5-44	5470 (9N70)	JK Edge Triggered Flip-Flop	5-98
5420 (9N20)	Dual 4-Input NAND Gate	5-56	54H71 (9H71)	JK M/S Flip-Flop	5-100
54H20 (9H20)	Dual 4-Input NAND Gate	5-55	5472 (9N72)	JK M/S Flip-Flop	5-104
54S20 (9S20)	Dual 4-Input NAND Gate	5-57	54H72 (9H72)	JK M/S Flip-Flop	5-102
54H21 (9H21)	High Speed AND Gate	5-58	5473 (9N73)	Dual JK M/S Flip-Flop	5-108
54H22 (9H22)	Dual 4-Input NAND Gate (Open Collector)	5-59	54H73 (9H73)	Dual JK M/S Flip-Flop	5-106
* 54S22 (9S22)	Dual 4-Input NAND Gate (Open Collector)	5-60	5474 (9N74)	Dual D Flip-Flop	5-112
5423 (9N23)	Dual 4-Input NOR Gate w/Strobe	5-61	54H74 (9H74)	Dual D Flip-Flop	5-110
5425 (9N25)	Dual 4-Input NOR Gate w/Strobe	5-61			
5426 (9N26)	Quad 2-Input High Voltage NAND Gate	5-67			
5427 (9N27)	Triple 3-Input NOR Gate	5-68			
5430 (9N30)	Single 8-Input NAND Gate	5-70			

*To be announced.

NUMERICAL INDEX OF DEVICES

DEVICE	DESCRIPTION	PAGE	DEVICE	DESCRIPTION	PAGE
54S74 (9S74)	Dual D Flip-Flop	5-114	54181 (9341)	4-Bit ALU	8-153
5475 (9375)	4-Bit Latch	8-211	54S181 (93S41)	4-Bit ALU	8-158
5476 (9N76)	Dual JK M/S Flip-Flop	5-118	54182 (9342)	Carry Lookahead Unit	8-163
54H76 (9H76)	Dual JK M/S Flip-Flop	5-116	54S182 (93S42)	Carry Lookahead Unit	8-167
5477 (9377)	4-Bit Latch	8-211	54H183 (93H183)	Dual Full Adder	8-288
54H78 (9H78)	Dual JK M/S Flip-Flop	5-120	54187 (93406)	1024-Bit Read Only Memory	9-13
5480 (9380)	Full Adder	8-215	54190 (93190)	Up/Down Decade Counter	8-292
5481 (93407)	16-Bit Read/Write Memory	9-23	54191 (93191)	Up/Down Binary Counter	8-292
5482 (9382)	2-Bit Full Adder	8-221	54192 (9360)	Up/Down Decade Counter	8-203
5483 (9383)	4-Bit Full Adder	8-225	54193 (9366)	Up/Down Binary Counter	8-203
5486 (9N86)	Quad Exclusive OR Gate	5-124	54195 (9300)	4-Bit Universal Shift Register	8-1
54H87 (93H87)	4-Bit True/Complement 0/1 Element	8-232	*54S195 (93S00)	4-Bit Universal Shift Register	8-14
5488A (93434)	256-Bit Read Only Memory	9-36	*54196 (93196)	Decade Counter	8-297
5489 (93403)	64-Bit Read/Write Memory	9-10	*54197 (93197)	Binary Counter	8-297
5490 (9390)	Decade Counter	8-236	*54198 (93198)	8-Bit Shift Register	8-301
5491 (9391)	8-Bit Shift Register	8-240	55107	Dual Line Receiver	7-34
5492 (9392)	Divide by 12 Counter	8-244	55108	Dual Line Receiver	7-34
5493 (9393)	Binary Counter	8-248	55109	Dual Line Driver	7-35
5494 (9394)	4-Bit Shift Register	8-252	55110	Dual Line Driver	7-35
5495 (9395)	4-Bit Right/Left Shift Register	8-254	7400 (9N00)	Quad 2-Input NAND Gate	5-28
5496 (9396)	5-Bit Shift Register	8-259	74H00 (9H00)	Quad 2-Input NAND Gate	5-25
54H101 (9H101)	JK Edge Triggered Flip-Flop	5-126	74S00 (9S00)	Quad 2-Input NAND Gate	5-29
54H102 (9H102)	JK Edge Triggered Flip-Flop	5-128	7401 (9N01)	Quad 2-Input NAND Gate (Open Collector)	5-31
54H103 (9H103)	Dual JK Edge Triggered Flip-Flop	5-130	74H01 (9H01)	Quad 2-Input NAND Gate (Open Collector)	5-30
54104 (9000)	JK M/S Flip-Flop	5-14	7402 (9N02)	Quad 2-Input NOR Gate	5-32
54105 (9001)	JK M/S Flip-Flop	5-14	7403 (9N03)	Quad 2-Input NAND Gate (Open Collector)	5-33
54H106 (9H106)	Dual JK Edge Triggered Flip-Flop	5-132	74S03 (9S03)	Quad 2-Input NAND Gate (Open Collector)	5-34
54107 (9N107)	Dual JK M/S Flip-Flop	5-108	7404 (9N04)	Hex Inverter	5-38
54H108 (9H108)	Dual JK Edge Triggered Flip-Flop	5-134	74H04 (9H04)	Hex Inverter	5-35
54S112 (9S112)	Dual JK Edge Triggered Flip-Flop	5-138	74S04 (9S04)	Hex Inverter	5-39
54S113 (9S113)	Dual JK Edge Triggered Flip-Flop	5-140	7405 (9N05)	Hex Inverter (Open Collector)	5-41
54S114 (9S114)	Dual JK Edge Triggered Flip-Flop	5-142	74H05 (9H05)	Hex Inverter (Open Collector)	5-40
54121 (9603)	One-Shot Multivibrator	7-21	74S05 (9S05)	Hex Inverter (Open Collector)	5-42
54S140 (9S140)	Dual 4-Input Line Driver	5-144	7406 (9N06)	Hex Inverter Buffer/Driver	5-43
54145 (93145)	1-of-10 Decoder/Driver	8-173	7407 (9N07)	Hex Buffer/Driver	5-44
54150 (93150)	16-Input Multiplexer	8-265	7408 (9N08)	Quad 2-Input AND Gate	5-46
54151 (93151)	8-Input Multiplexer	8-265	74H08 (9H08)	Quad 2-Input AND Gate	5-45
54152 (93152)	8-Input Multiplexer	8-265	7409 (9N09)	Quad 2-Input AND Gate (Open Collector)	5-47
54153 (93153)	Dual 4-Input Multiplexer	8-272	7410 (9N10)	Triple 3-Input NAND Gate	5-49
54154 (9311)	1-of-16 Decoder	8-66	74H10 (9H10)	Triple 3-Input NAND Gate	5-48
54157 (9322)	Quad 2-Input Multiplexer	8-117	7411 (9N11)	Triple 3-Input AND Gate	5-51
54160 (9310)	Decade Counter	8-54	74H11 (9H11)	Triple 3-Input AND Gate	5-50
54161 (9316)	Binary Counter	8-54	7412 (9N12)	Triple 3-Input NAND Gate (Open Collector)	5-52
*54164 (93164)	8-Bit Serial to Parallel Converter	8-276	7413 (9N13)	Dual 4-Input NAND Schmitt Trigger	5-53
54165 (93165)	8-Bit Parallel to Serial Converter	8-279	7416 (9N16)	Hex Inverter Buffer/Driver	5-43
*54176 (93176)	BCD Decade Counter	8-282	7417 (9N17)	Hex Buffer/Driver	5-44
*54177 (93177)	Binary Counter	8-282			
*54178 (93178)	4-Bit Shift Register	8-283			
*54179 (93179)	4-Bit Shift Register	8-283			
54180 (93180)	8-Bit Parity Generator/Checker	8-284			

*To be announced.

NUMERICAL INDEX OF DEVICES

DEVICE	DESCRIPTION	PAGE	DEVICE	DESCRIPTION	PAGE
7420 (9N20)	Dual 4-Input NAND Gate	5-56	74H60 (9H60)	Dual 4-Input Expander	5-92
74H20 (9H20)	Dual 4-Input NAND Gate	5-55	74H61 (9H61)	Triple 3-Input Expander	5-94
74S20 (9S20)	Dual 4-Input NAND Gate	5-57	74H62 (9H62)	3-2-2-3-Input AND/OR Expander	5-95
74H21 (9H21)	High Speed AND Gate	5-58	74S64 (9S64)	4-2-3-2-Input AND/OR Invert Gate	5-96
74H22 (9H22)	Dual 4-Input NAND Gate (Open Collector)	5-59	74S65 (9S65)	4-2-3-2-Input AND/OR Invert Gate (Open Collector)	5-97
74S22 (9S22)	Dual 4-Input NAND Gate (Open Collector)	5-60	7470 (9N70)	JK Edge Triggered Flip-Flop	5-98
7423 (9N23)	Dual 4-Input NOR Gate w/Strobe	5-61	74H71 (9H71)	JK M/S Flip-Flop	5-100
7425 (9N25)	Dual 4-Input NOR Gate w/Strobe	5-61	7472 (9N72)	JK M/S Flip-Flop	5-104
7426 (9N26)	Quad 2-Input High Voltage NAND Gate	5-67	74H72 (9H72)	JK M/S Flip-Flop	5-102
7427 (9N27)	Triple 3-Input NOR Gate	5-68	7473 (9N73)	Dual JK M/S Flip-Flop	5-108
7430 (9N30)	Single 8-Input NAND Gate	5-70	74H73 (9H73)	Dual JK M/S Flip-Flop	5-106
74H30 (9H30)	Single 8-Input NAND Gate	5-69	7474 (9N74)	Dual D Flip-Flop	5-112
7432 (9N32)	Quad 2-Input OR Gate	5-71	74H74 (9H74)	Dual D Flip-Flop	5-110
7437 (9N37)	Quad 2-Input NAND Gate/Buffer	5-72	74S74 (9S74)	Dual D Flip-Flop	5-114
7438 (9N38)	Quad 2-Input NAND Gate/Buffer (Open Collector)	5-72	7475 (9375)	4-Bit Latch	8-211
7439 (9N39)	Quad 2-Input NAND Gate/Buffer (Open Collector)	5-74	7476 (9N76)	Dual JK M/S Flip-Flop	5-118
7440 (9N40)	Dual 4-Input Buffer	5-76	74H76 (9H76)	Dual JK M/S Flip-Flop	5-116
74H40 (9H40)	Dual 4-Input Buffer	5-75	7477 (9377)	4-Bit Latch	8-211
74S40 (9S40)	Dual 4-Input Buffer	5-77	74H78 (9H78)	Dual JK M/S Flip-Flop	5-120
7441 (9315)	1-of-10 Decoder/Driver	8-95	7480 (9380)	Full Adder	8-215
7442 (9352)	BCD to Decimal Decoder/Driver	8-183	7481 (93407)	16-Bit Read/Write Memory	9-23
7443 (9353)	Excess 3 to Decimal Decoder	8-183	7482 (9382)	2-Bit Full Adder	8-221
7444 (9354)	Excess 3 Gray to Decimal Decoder	8-183	7483 (9383)	4-Bit Full Adder	8-225
7445 (9345)	1-of-10 Decoder	8-173	7486 (9N86)	Quad Exclusive OR Gate	5-124
7446 (9357A)	BCD to 7-Segment Decoder/Driver	8-191	74H87 (93H87)	4-Bit True/Complement 0/1 Element	8-232
7447 (9357B)	BCD to 7-Segment Decoder/Driver	8-191	7488A (93434)	256-Bit Read Only Memory	9-36
7448 (9358)	BCD to 7-Segment Decoder	8-197	7489 (93403)	64-Bit Read/Write Memory	9-10
7449 (9359)	BCD to 7-Segment Decoder	8-197	7490 (9390)	Decade Counter	8-236
7450 (9N50)	Dual AND/OR Gate Inverter/Expander	5-80	7491 (9391)	8-Bit Shift Register	8-240
74H50 (9H50)	Dual AND/OR Gate Inverter/Expander	5-78	7492 (9392)	Divide by 12 Counter	8-244
7451 (9N51)	Dual 2-Input AND/OR Invert Gate	5-80	7493 (9393)	Binary Counter	8-248
74H51 (9H51)	Dual 2-Input AND/OR Invert Gate	5-78	7494 (9394)	4-Bit Shift Register	8-252
74H52 (9H52)	2-2-2-3-Input AND/OR Gate	5-82	7495 (9395)	4-Bit Right/Left Shift Register	8-254
7453 (9N53)	Expandable 4 Wide 2-Input AND/OR Invert Gate	5-86	7496 (9396)	5-Bit Shift Register	8-259
74H53 (9H53)	Expandable 2-2-2-3-Input AND/OR Invert Gate	5-84	74H101 (9H101)	JK Edge Triggered Flip-Flop	5-126
7454 (9N54)	4 Wide 2-Input AND/OR Invert Gate	5-86	74H102 (9H102)	JK Edge Triggered Flip-Flop	5-128
74H54 (9H54)	2-2-2-3-Input AND/OR Invert Gate	5-84	74H103 (9H103)	Dual JK Edge Triggered Flip-Flop	5-130
74H55 (9H55)	2 Wide 4-Input AND/OR Invert Gate	5-90	74104 (9000)	JK M/S Flip-Flop	5-14
7460 (9N60)	Dual 4-Input Expander	5-93	74105 (9001)	JK M/S Flip-Flop	5-14
			74H106 (9H106)	Dual JK Edge Triggered Flip-Flop	5-132
			74107 (9N107)	Dual JK M/S Flip-Flop	5-108
			74H108 (9H108)	Dual JK Edge Triggered Flip-Flop	5-134
			74S112 (9S112)	Dual JK Edge Triggered Flip-Flop	5-138
			74S113 (9S113)	Dual JK Edge Triggered Flip-Flop	5-140
			74S114 (9S114)	Dual JK Edge Triggered Flip-Flop	5-142
			74121 (9603)	One-Shot Multivibrator	7-21
			74S140 (9S140)	Dual 4-Input Line Driver	5-144
			74141 (93141)	BCD to Decimal Decoder/Driver	8-261

NUMERICAL INDEX OF DEVICES

DEVICE	DESCRIPTION	PAGE	DEVICE	DESCRIPTION	PAGE
74145 (93145)	1-of-10 Decoder/Driver	8-173	9S03 (54/74S03)	Quad 2-Input NAND Gate (Open Collector)	5-34
74150 (93150)	16-Input Multiplexer	8-265	9004	Dual 4-Input NAND Gate	5-2
74151 (93151)	8-Input Multiplexer	8-265	9H04 (54/74H04)	Hex Inverter	5-35
74152 (93152)	8-Input Multiplexer	8-265	9L04	Hex Inverter	5-36
74153 (93153)	Dual 4-Input Multiplexer	8-272	9N04 (54/7404)	Hex Inverter	5-38
74154 (9311)	1-of-16 Decoder	8-66	9S04 (54/74S04)	Hex Inverter	5-39
74157 (9322)	Quad 2-Input Multiplexer	8-117	9S04A	Hex Inverter	5-39
74160 (9310)	Decade Counter	8-54	9005	Dual AND/OR Invert Gate/Expander	5-5
74161 (9316)	Binary Counter	8-54	9H05 (54/74H05)	Hex Inverter (Open Collector)	5-40
*74164 (93164)	8-Bit Serial to Parallel Converter	8-276	9N05 (54/7405)	Hex Inverter (Open Collector)	5-41
74165 (93165)	8-Bit Parallel to Serial Converter	8-279	9S05 (54/74S05)	Hex Inverter (Open Collector)	5-42
*74176 (93176)	BCD Decade Counter	8-282	9S05A	Hex Inverter (Open Collector)	5-42
*74177 (93177)	Binary Counter	8-282	9006	Dual 4-Input Expander	5-5
*74178 (93178)	4-Bit Shift Register	8-283	9N06 (54/7406)	Hex Inverter Buffer/Driver	5-43
*74179 (93179)	4-Bit Shift Register	8-283	9007	8-Input NAND Gate	5-2
74180 (93180)	8-Bit Parity Generator/Checker	3-284	9N07 (54/7407)	Hex Buffer/Driver	5-44
74181 (9341)	4-Bit ALU	8-153	9008	2-2-2-3-Input AND/OR Invert Gate	5-5
74S181 (93S41)	4-Bit ALU	8-158	9H08 (54/74H08)	Quad 2-Input AND Gate	5-45
74182 (9342)	Carry Lookahead Unit	8-163	9N08 (54/7408)	Quad 2-Input AND Gate	5-46
74S182 (93S42)	Carry Lookahead Unit	8-167	9009	Dual 4-Input NAND Buffer	5-9
74H183 (93H183)	Dual Full Adder	8-288	9N09 (54/7409)	Quad 2-Input AND Gate (Open Collector)	5-47
74187 (93406)	1024-Bit Read Only Memory	9-13	9H10 (54/74H10)	Triple 3-Input NAND Gate	5-48
74190 (93190)	Up/Down Decade Counter	8-292	9N10 (54/7410)	Triple 3-Input NAND Gate	5-49
74191 (93191)	Up/Down Binary Counter	8-292	9H11 (54/74H11)	Triple 3-Input AND Gate	5-50
74192 (9360)	Up/Down Decade Counter	8-203	9N11 (54/7411)	Triple 3-Input AND Gate	5-51
74193 (9366)	Up/Down Binary Counter	8-203	9012	Quad 2-Input NAND Gate (Open Collector)	5-2
74195 (9300)	4-Bit Universal Shift Register	8-1	9N12 (54/7412)	Triple 3-Input NAND Gate (Open Collector)	5-52
*74S195 (93S00)	4-Bit Universal Shift Register	8-14	9N13 (54/7413)	Dual 4-Input NAND Schmitt Trigger	5-53
*74196 (93196)	Decade Counter	8-297	9014	Quad Exclusive OR Gate	5-11
*74197 (93197)	Binary Counter	8-297	9015	2-2-2-4-Input NOR Gate	5-13
*74198 (93198)	8-Bit Shift Register	8-301	9016	Hex Inverter	5-2
75107	Dual Line Receiver	7-34	9N16 (54/7416)	Hex Inverter Buffer/Driver	5-43
75108	Dual Line Receiver	7-34	9017	Hex Inverter (Open Collector)	5-2
75109	Dual Line Driver	7-35	9N17 (54/7417)	Hex Buffer/Driver	5-44
75110	Dual Line Driver	7-35	9020	Dual JK Flip-Flop	5-14
75450	Dual Peripheral Driver	7-36	9H20 (54/74H20)	Dual 4-Input NAND Gate	5-55
9000 (54/74104)	JK M/S Flip-Flop	5-14	9N20 (54/7420)	Dual 4-Input NAND Gate	5-56
9H00 (54/74H00)	Quad 2-Input NAND Gate	5-25	9S20 (54/74S20)	Dual 4-Input NAND Gate	5-57
9L00	Quad 2-Input NAND Gate	5-26	9H21 (54/74H21)	High Speed AND Gate	5-58
9N00 (54/7400)	Quad 2-Input NAND Gate	5-28	9022	Dual JK M/S Flip-Flop	5-14
9S00 (54/74S00)	Quad 2-Input NAND Gate	5-29	9H22 (54/74H22)	Dual 4-Input NAND Gate (Open Collector)	5-59
9001 (54/74105)	JK M/S Flip-Flop	5-14	9S22 (54/74S22)	Dual 4-Input NAND Gate (Open Collector)	5-60
9H01 (54/74H01)	Quad 2-Input NAND Gate (Open Collector)	5-30	9N23 (54/7423)	Dual 4-Input NOR Gate w/Strobe	5-61
9N01 (54/7401)	Quad 2-Input NAND Gate (Open Collector)	5-31	9024	Dual JK Flip-Flop	5-22
9002	Quad 2-Input NAND Gate	5-2			
9N02 (54/7402)	Quad 2-Input NOR Gate	5-32			
9003	Triple 3-Input NAND Gate	5-2			
9N03 (54/7403)	Quad 2-Input NAND Gate (Open Collector)	5-33			

*To be announced.

NUMERICAL INDEX OF DEVICES

DEVICE	DESCRIPTION	PAGE	DEVICE	DESCRIPTION	PAGE
9L24	Dual JK Flip-Flop	5-63	9N74 (54/7474)	Dual D Flip-Flop	5-112
9N25 (54/7425)	Dual 4-Input NOR Gate w/Strobe	5-61	9S74 (54/74S74)	Dual D Flip-Flop	5-114
9N26 (54/7426)	Quad 2-Input High Voltage NAND Gate	5-67	9H76 (54/74H76)	Dual JK M/S Flip-Flop	5-116
9N27 (54/7427)	Triple 3-Input NOR Gate	5-68	9N76 (54/7476)	Dual JK M/S Flip-Flop	5-118
9H30 (54/74H30)	Single 8-Input NAND Gate	5-69	9H78 (54/74H78)	Dual JK M/S Flip-Flop	5-120
9N30 (54/7430)	Single 8-Input NAND Gate	5-70	9L86	Quad Exclusive OR Gate	5-122
9N32 (54/7432)	Quad 2-Input OR Gate	5-71	9N86 (54/7486)	Quad Exclusive OR Gate	5-124
9033	See 93433	9-23	9H101 (54/74H101)	JK Edge Triggered Flip-Flop	5-126
9034	See 93434	9-36	9H102 (54/74H102)	JK Edge Triggered Flip-Flop	5-128
9035	See 93435	9-39	9H103 (54/74H103)	Dual JK Edge Triggered Flip-Flop	5-130
9N37 (54/7437)	Quad 2-Input NAND Gate/Buffer	5-72	9H106 (54/74H106)	Dual JK Edge Triggered Flip-Flop	5-132
9N38 (54/7438)	Quad 2-Input NAND Gate/Buffer (Open Collector)	5-72	9N107 (54/74107)	Dual JK M/S Flip-Flop	5-108
9N39 (54/7439)	Quad 2-Input NAND Gate/Buffer (Open Collector)	5-74	9H108 (54/74H108)	Dual JK Edge Triggered Flip-Flop	5-134
9H40 (54/74H40)	Dual 4-Input Buffer	5-75	9S109	Dual JK Flip-Flop	5-136
9N40 (54/7440)	Dual 4-Input Buffer	5-76	9S112 (54/74S112)	Dual JK Edge Triggered Flip-Flop	5-138
9S40 (54/74S40)	Dual 4-Input Buffer	5-77	9S113 (54/74S113)	Dual JK Edge Triggered Flip-Flop	5-140
9H50 (54/74H50)	Dual AND/OR Invert Gate/Expander	5-78	9S114 (54/74S114)	Dual JK Edge Triggered Flip-Flop	5-142
9N50 (54/7450)	Dual AND/OR Invert Gate/Expander	5-80	9S140 (54/74S140)	Dual 4-Input Line Driver	5-144
9H51 (54/74H51)	Dual 2-Input AND/OR Invert Gate	5-78	9300	4-Bit Shift Register	8-1
9N51 (54/7451)	Dual 2-Input AND/OR Invert Gate	5-80	93H00	4-Bit Shift Register	8-6
9H52 (54/74H52)	2-2-2-3-Input AND/OR Gate	5-82	93L00	4-Bit Shift Register	8-10
9H53 (54/74H53)	Expandable 2-2-2-3-Input AND/OR Invert Gate	5-84	*93S00	4-Bit Shift Register	8-14
9N53 (54/7453)	Expandable 4 Wide 2-Input AND/OR Invert Gate	5-86	9301	1-of-10 Decoder	8-15
9H54 (54/74H54)	2-2-2-3-Input AND/OR Invert Gate	5-84	93L01	1-of-10 Decoder	8-18
9L54	2-2-2-3-Input AND/OR Invert Gate	5-88	9302	1-of-10 Decoder (Open Collector)	8-21
9N54 (54/7454)	4 Wide 2-Input AND/OR Invert Gate	5-86	9304	Dual Full Adder	8-24
9H55 (54/74H55)	2 Wide 4-Input AND/OR Invert Gate	5-90	9305	Variable Modulo Counter	8-28
9H60 (54/74H60)	Dual 4-Input Expander	5-92	93S05	Variable Modulo Counter	8-33
9N60 (54/7460)	Dual 4-Input Expander	5-93	9307	7-Segment Decoder	8-34
9H61 (54/74H61)	Triple 3-Input Expander	5-94	9308	Dual 4-Bit Latch	8-38
9H62 (54/74H62)	3-2-2-3-Input AND/OR Expander	5-95	93L08	Dual 4-Bit Latch	8-43
9S64 (54/74S64)	4-2-3-2-Input AND/OR Invert Gate	5-96	9309	Dual 4-Input Multiplexer	8-47
9S65 (54/74S65)	4-2-3-2-Input AND/OR Invert Gate (Open Collector)	5-97	93L09	Dual 4-Input Multiplexer	8-51
9N70 (54/7470)	JK Edge Triggered Flip-Flop	5-98	9310	Decade Counter	8-54
9H71 (54/74H71)	JK M/S Flip-Flop	5-100	93L10	Decade Counter	8-60
9H72 (54/74H72)	JK M/S Flip-Flop	5-102	*93S10	Decade Counter	8-65
9N72 (54/7472)	JK M/S Flip-Flop	5-104	9311	1-of-16 Decoder	8-66
9H73 (54/74H73)	Dual JK M/S Flip-Flop	5-106	93L11	1-of-16 Decoder	8-69
9N73 (54/7473)	Dual JK M/S Flip-Flop	5-108	9312	8-Input Multiplexer	8-72
9H74 (54/74H74)	Dual D Flip-Flop	5-110	93L12	8-Input Multiplexer	8-76
			*93S12	8-Input Multiplexer	8-79
			9313	8-Input Multiplexer (Open Collector)	8-80
			9314	4-Bit Latch	8-85
			93L14	4-Bit Latch	8-90
			9315	1-of-10 Decoder/Driver	8-95
			9316	4-Bit Binary Counter	8-54
			93L16	4-Bit Binary Counter	8-60
			*93S16	4-Bit Binary Counter	8-65
			9317B	7-Segment Decoder/Driver	8-98
			9317C	7-Segment Decoder/Driver	8-98

*To be announced.

NUMERICAL INDEX OF DEVICES

DEVICE	DESCRIPTION	PAGE	DEVICE	DESCRIPTION	PAGE
9318	8-Input Priority Encoder	8-103	9394 (54/7494)	4-Bit Shift Register	8-252
93L18	8-Input Priority Encoder	8-107	9395 (54/7495)	4-Bit Right/Left Shift Register	8-254
9321	Dual 1-of-4 Decoder	8-111	9396 (54/7496)	5-Bit Shift Register	8-259
93L21	Dual 1-of-4 Decoder	8-114	93141 (74141)	BCD to Decimal Decoder/Driver	8-261
9322	Quad 2-Input Multiplexer	8-117	93145 (54/74145)	1-of-10 Decoder/Driver	8-173
93L22	Quad 2-Input Multiplexer	8-121	93150 (54/74150)	16-Input Multiplexer	8-265
9324	5-Bit Comparator	8-124	93151 (54/74151)	8-Input Multiplexer	8-265
93L24	5-Bit Comparator	8-128	93152 (54/74152)	8-Input Multiplexer	8-265
9328	Dual 8-Bit Shift Register	8-131	93153 (54/74153)	Dual 4-Input Multiplexer	8-272
93L28	Dual 8-Bit Shift Register	8-135	*93164 (54/74164)	8-Bit Serial to Parallel Converter	8-276
9334	8-Bit Addressable Latch	8-138	93165 (54/74165)	8-Bit Parallel to Serial Converter	8-279
9338	8-Bit Multiport Register	8-142	*93176 (54/74176)	BCD Decade Counter	8-282
*93S39	8-Bit Multiport Register	8-147	*93177 (54/74177)	Binary Counter	8-282
9340	4-Bit ALU	8-148	*93178 (54/74178)	4-Bit Shift Register	8-283
			*93179 (54/74179)	4-Bit Shift Register	8-283
9341 (54/74181)	4-Bit ALU	8-153	93180 (54/74180)	8-Bit Parity Generator/Checker	8-284
93S41	4-Bit ALU	8-158	93H183 (54/74H183)	Dual Full Adder	8-288
9342 (54/74182)	Carry Lookahead Unit	8-163	93190 (54/74190)	Up/Down Decade Counter	8-292
93S42	Carry Lookahead Unit	8-167	93191 (54/74191)	Up/Down Binary Counter	8-292
9344	4-Bit by 2-Bit Multiplier	8-168	*93196 (54/74196)	Decade Counter	8-297
9345 (54/7445)	1-of-10 Decoder	8-173	*93197 (54/74197)	Binary Counter	8-297
9348	12-Input Parity Checker/Generator	8-177	*93198 (54/74198)	8-Bit Shift Register	8-301
			93400	256-Bit Read/Write Memory	9-1
9350	Decade Counter	8-180	93400B	256-Bit Read/Write Memory	9-1
9352 (54/7442)	BCD to Decimal Decoder	8-183	93401	Decoder/Driver for 93400	9-1
9353 (54/7443)	Excess 3 to Decimal Decoder	8-183	93402	16-Bit CAM	9-6
9354 (54/7444)	Excess 3 Gray to Decimal Decoder	8-183	93403 (54/7489)	64-Bit Read/Write Memory	9-10
			93406 (54/74187)	1024-Bit Read Only Memory	9-13
9356	Binary Counter	8-188	93407 (54/7481)	16-Bit Read/Write Memory	9-23
9357A (54/7446)	BCD to 7-Segment Decoder/Driver	8-191	93410	256-Bit Read/Write Memory	9-27
			93415	1024-Bit Read/Write Memory	9-32
9357B (54/7447)	BCD to 7-Segment Decoder/Driver	8-191	93433	16-Bit Read/Write Memory	9-23
			93434 (54/7488A)	256-Bit Read Only Memory	9-35
9358 (54/7448)	BCD to 7-Segment Decoder	8-197	93435	64-Bit Read/Write Memory	9-38
9359 (54/7449)	BCD to 7-Segment Decoder	8-197	9600	One-Shot Multivibrator	7-1
9360 (54/74192)	Up/Down Decade Counter	8-203	9601	One-Shot Multivibrator	7-6
*93S62	9-Bit Parity Checker/Generator	8-206	9602	Dual One-Shot Multivibrator	7-11
9366 (54/74193)	Up/Down Binary Counter	8-203	96L02	Dual One-Shot Multivibrator	7-16
93H72	4-Bit Shift Register	8-207		One-Shot Multivibrator	7-21
9375 (54/7475)	4-Bit Latch	8-211	9603 (54/74121)	One-Shot Multivibrator	7-21
9377 (54/7477)	4-Bit Latch	8-211	9614	Dual Line Driver	7-25
9380 (54/7480)	Full Adder	8-215	9615	Dual Line Receiver	7-26
9382 (54/7482)	2-Bit Full Adder	8-221	9616	EIA Line Driver	7-27
9383 (54/7483)	4-Bit Full Adder	8-225	9617	EIA Line Receiver	7-28
9386	Quad Exclusive NOR/Comparator	8-230	9620	Dual Line Receiver	7-29
93H87 (54/74H87)	4-Bit True/Complement 0/1 Element	8-232	9621	Dual Line Driver	7-30
			9622	Dual Line Receiver	7-31
9390 (54/7490)	Decade Counter	8-236	9624	Dual TTL to MOS Interface	7-32
9391 (54/7491)	8-Bit Shift Register	8-240	9625	Dual MOS to TTL Interface	7-32
9392 (54/7492)	Divide by 12 Counter	8-244	9644	Dual High Voltage High Current Driver	7-33
9393 (54/7493)	Binary Counter	8-248			

*To be announced.

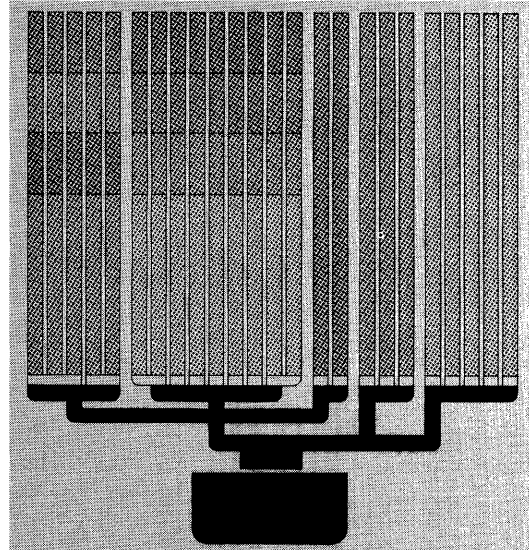

Selector Guide and Functional Index

The following selector guides provide a comparison of the key parameters for all Fairchild TTL devices. They should be used to help determine the most suitable device for a specific application. Final selection should be made using the appropriate data sheet.

Charts are provided covering the following device categories.

SSI











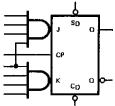

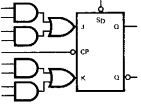

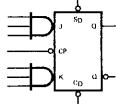
- Gates, Buffers and Inverters
- Flip-Flops
- Monostables
- Interface-Drivers
- Interface-Receivers
- Interface-Level Translators

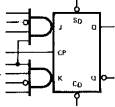
MSI/MEMORIES

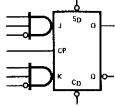
- Arithmetic Operators
 - Adders, ALU.S, Comparators, Multipliers, Parity Checkers.
- Counters
- Decoders-Display
- Decoders/Demultiplexers
- Encoders
- Latches
- Memories [RAM (Read/Write), ROM, Associative]
- Multiplexers
- Registers

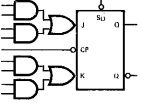

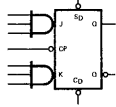







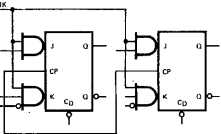

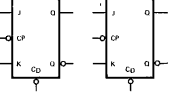

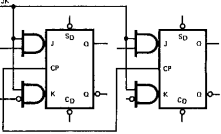

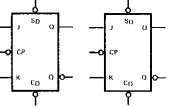

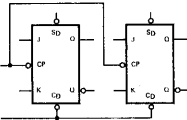

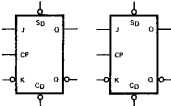

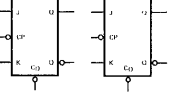

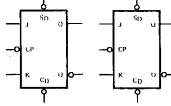

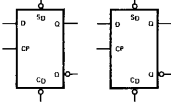
3
4
5
6
7
8
9
10
11
12

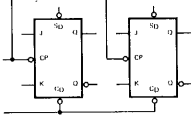
SINGLE FLIP-FLOP SELECTOR GUIDE

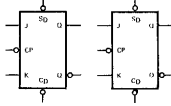
	OUTPUT CHANGES ON POSITIVE GOING EDGE	OUTPUT CHANGES ON NEGATIVE GOING EDGE	
MASTER/SLAVE	 <p>9000/74104 20 MHz/16 ns</p> 	<p>9H71/74H71 30 MHz/22 ns</p>  	<p>9N72/7472 20 MHz/25 ns 9H72/74H72 30 MHz/22 ns</p>  
	 <p>9001/74105 50 MHz/16 ns</p> 		
EDGE TRIGGERED	 <p>9N70/7470 35 MHz/27 ns</p> 	 <p>9H101/74H101 50 MHz/16 ns</p> 	 <p>9H102/74H102 50 MHz/16 ns</p> 

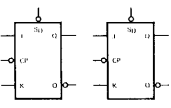
3

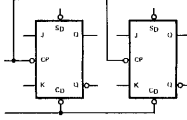
DUAL FLIP-FLOP SELECTOR GUIDE

MASTER/SLAVE	 <p>9020 50 MHz/16 ns</p> 	 <p>9N73/7473 • 9N107/74107 20 MHz/25 ns 9H73/74H73 30 MHz/22 ns</p> 	
	 <p>9022 50 MHz/16 ns</p> 	 <p>9N76/7476 20 MHz/25 ns 9H76/74H76 30 MHz/22 ns</p> 	 <p>9H78/74H78 30 MHz/22 ns</p> 
EDGE TRIGGERED	 <p>9024 25 MHz/22 ns 9L24 8 MHz/66 ns 9S109 100 MHz/7 ns</p> 	 <p>9H103/74H103 50 MHz/16 ns</p> 	 <p>9H106/74H106 50 MHz/16 ns</p> 
	 <p>9N74/7474 25 MHz/20 ns 9H74/74H74 43 MHz/13 ns 9S74/74S74 100 MHz/7 ns</p> 	 <p>9H108/74H108 50MHz/16 ns</p> 	 <p>9S112/74S112 125 MHz/5 ns</p> 
		 <p>9S113/74S113 125 MHz/5 ns</p> 	 <p>9S114/74S114 125 MHz/5 ns</p> 

MASTER/SLAVE (or "ONES CATCHING" MASTER/SLAVE)—The master is sensitive to input conditions during the active portion of the clock pulse.
EDGE TRIGGERED — Only sensitive to input conditions immediately prior to active clock edge.

SSI • GATES, BUFFERS AND INVERTERS

	LOW POWER		STANDARD	
	$t_{pd} = 20 \text{ ns}$ $P_d = 2 \text{ mW per Gate}$		$t_{pd} = 10 \text{ ns}$ $P_d = 10 \text{ mW per Gate}$	
	$0^\circ \text{C to } +70^\circ \text{C and}$ $-55^\circ \text{ to } +125^\circ \text{C}$		$0^\circ \text{ to } +70^\circ \text{C}$	$-55^\circ \text{ to } +125^\circ \text{C}$
NAND GATES				
Quad 2-Input Positive NAND Gate	9L00	9N00/7400	9N00/5400	
Quad 2-Input Positive NAND Gate with Open-Collector Output		9N01/7401 9N03/7403	9N01/5401 9N03/5403	
Quad 2-Input Positive NAND Gate (15 Volts)		9N26/7426	9N26/5426	
Triple 3-Input Positive NAND Gate		9N10/7410	9N10/5410	
Triple 3-Input Positive NAND (Open Collector)		9N12/7412	9N12/5412	
Dual 4-Input Positive NAND Gate		9N20/7420	9N20/5420	
8-Input Positive NAND Gate		9N30/7430	9N30/5430	
NOR GATES				
Quad 2-Input Positive NOR Gate		9N02/7402	9N02/5402	
Quad 2-2-2-4-Input Positive NOR Gate				
Triple 3-Input Positive NOR Gate		9N27/7427	9N27/5427	
Dual 4-Input Positive NOR Gate (with strobe)		9N23,25/7423,25	9N23,25/5423,25	
AND GATES				
Quad 2-Input Positive AND Gate		9N08/7408	9N08/5408	
Quad 2-Input Positive AND Gate (Open Collector)		9N09/7409	9N09/5409	
Triple 3-Input Positive AND Gate		9N11/7411	9N11/5411	
Dual 4-Input Positive AND Gate				
OR GATES				
Quad 2-Input Positive OR Gate		9N32/7432	9N32/5432	
EXCLUSIVE-OR GATES				
Quad Exclusive-OR Gate	9L86	9N86/7486	9N86/5486	
Quad Exclusive-OR Gate with Inverted Outputs				
AND-OR, AND-OR-INVERT GATES AND EXPANDERS				
Expandable 2-2-2-3 Input AND-OR Gate				
Dual 2-Wide 2-Input AND-OR-INVERT Gate		9N51/7451	9N51/5451	
Expandable Dual 2-Wide 2-Input AND-OR-INVERT Gate		9N50/7450	9N50/5450	
Expandable 2-Wide, 4-Input AND-OR-INVERT Gate				
4-Wide 2-Input AND-OR-INVERT Gate	9L54	9N54/7454	9N54/5454	
4-2-3-2-Input AND-OR-INVERT Gate				
4-2-3-2-Input AND-OR-INVERT Gate (Open Collector)				
Expandable 4-Wide 2-Input AND-OR-INVERT Gate		9N53/7453	9N53/5453	
Expandable 4-Wide 2-2-2-3-Input AND-OR-INVERT Gate				
Triple 3-Input Expander				
Dual 4-Input Expander		9N60/7460	9N60/5460	
3-2-2-3-Input AND-OR Expander				
INVERTERS AND BUFFERS				
Hex Inverter	9L04	9N04/7404	9N04/5404	
Hex Inverter with Open-Collector Output		9N05/7405	9N05/5405	
Hex Inverter Buffer/Driver (30 Volts)		9N06/7406	9N06/5406	
Hex Inverter Buffer/Driver (15 Volts)		9N16/7416	9N16/5416	
Hex Buffer/Drivers (30 Volts)		9N07/7407	9N07/5407	
Hex Buffer/Drivers (15 Volts)		9N17/7417	9N17/5417	
Quad 2-Input Positive NAND Buffer		9N37/7437	9N37/5437	
Quad 2-Input Positive NAND Buffer (Open Collector)		9N38/7438	9N38/5438	
Quad 2-Input Positive NAND Buffer (Open Collector - 15 Volts)		9N39/7439		
Dual 4-Input Positive NAND Buffer		9N40/7440	9N40/5440	
Dual 4-Input Positive NAND 50 Ω Driver				
SCHMITT TRIGGER				
Dual NAND Schmitt Trigger		9N13/7413	9N13/5413	

SSI • GATES, BUFFERS AND INVERTERS

STANDARD	HIGH SPEED		SUPER HIGH SPEED (SCHOTTKY)	
$t_{pd} = 8 \text{ ns}$ $P_d = 10 \text{ mW per Gate}$	$t_{pd} = 6 \text{ ns}$ $P_d = 22 \text{ mW per Gate}$		$t_{pd} = 3 \text{ ns}$ $P_d = 19 \text{ mW per Gate}$	
$0^\circ\text{C to } +70^\circ\text{C}$ and $-55^\circ\text{ to } +125^\circ\text{C}$	$0^\circ\text{ to } +70^\circ\text{C}$	$-55^\circ\text{ to } +125^\circ\text{C}$	$0^\circ\text{ to } +70^\circ\text{C}$	$-55^\circ\text{ to } +125^\circ\text{C}$
9002	9H00/74H00 9H01/74H01	9H00/54H00 9H01/54H01	9S00/74S00	9S00/54S00
9012			9S03/74S03	*9S03/54S03
9003	9H10/74H10	9H10/54H10	*9S10/74S10	*9S10/54S10
9004	9H20,22/74H20,22	9H20,22/54H20,22	9S20,22/74S20,22	9S20*, 22/54S20*, 22
9007	9H30/74H30	9H30/54H30		
9015				
	9H08/74H08	9H08/54H08		
	9H11/74H11	9H11/54H11	*9S11/74S11	*9S11/54S11
	9H21/74H21	9H21/54H21		
9014				
9005	9H52/74H52 9H51/74H51 9H50/74H50 9H55/74H55 *9H54/74H54	9H52/54H52 9H51/54H51 9H50/54H50 9H55/54H55 *9H54/54H54	9S64/74S64 9S65/74S65	9S64/54S64 *9S65/54S65
9008	*9H53/74H53	*9H53/54H53		
9006	9H61/74H61 9H60/74H60 *9H62/74H62	9H61/54H61 9H60/54H60 *9H62/54H62		
9016	9H04/74H04	9H04/54H04	9S04/74S04, 9S04A	9S04/54S04, 9S04A
9017	9H05/74H05	9H05/54H05	9S05/74S05, 9S05A	*9S05/54S05, *9S05A
9009	9H40/74H40	9H40/54H40	9S40/74S40 9S140/74S140	9S40/54S40 9S140/54S140

* To be announced.

SELECTOR GUIDE/FUNCTIONAL INDEX

SSI MONOSTABLES

Function	Type No.	Pulse Width Variation (%)		Number of Inputs		Resettable	Min. Output t_{pw} ns	Power Dissipation mW	Page No.
		vs. Temp	vs. V_{CC}	Positive	Negative				
Single Retriggerable	9600	± 1.5	± 1.5	3	2	x	75	125	7-1
	9601	± 2.7	± 1.0	2	2		50	125	7-6
Dual Retriggerable	9602	± 1.5	± 1.5	1	1	x	72	250	7-11
	96L02	± 0.4	± 1.5	1	1	x	110	50	7-16
Single Non-Retriggerable	9603	± 0.2	± 0.15	1	2		40	90	7-21

SSI INTERFACE – DRIVERS

Function	Type No.	Companion Receiver	Supply Voltages	V_{OH}	V_{OL}	t_{pd} ns	Power Dissipation mW	Page No.
			V	V	V			
Single +5 V Operation	9614	9615	+5.0	+3.2	+0.2	16	175	7-25
EIA RS232 Operation	9616	9617	+12	+6	-6	300	250	7-27
			-12	+4.3	+0.2	10	120	7-30
General Purpose	75109	75107	+5 -5	O.C.*	O.C.*	9	180	7-35
	75110	75108	+5 -5	O.C.*	O.C.*	9	180	7-35
High Voltage	9644		+5	30	0.8	50	120	7-33
	75450		+5	30	0.4	20	30	7-36

*Open Collector

SSI INTERFACE – RECEIVERS

Function	Type No.	Companion Driver	Supply Voltages	V_{TH}	V_{CM}	Output Enable	Diff. Inputs	t_{pd} ns	Power Dissipation mW	Page No.
			V	V	V					
Single +5 V Operation	9615	9614	+5	± 0.5	± 15	x	x	28	175	7-26
EIA RS-232 Operation	9617	9616	+5	+1.5	± 25			50	100	7-28
General Purpose	9620	9621	+5 -12	± 0.5	± 15		x	30	110	
	9622	9621	+5 -10	± 2.0	± 10	x	x	35	140	7-31
	75107	75109	± 5	± 0.25	± 3	x	x	19	180	7-34
	75108	75110	± 5	± 0.25	± 3	x	x	19	180	7-34

SSI INTERFACE – LEVEL TRANSLATORS

Function	Type No.	Supply Voltages		V_{OH} V	V_{OL} V	t_{pd} ns	Power Dissipation mW	Page No.
		+V	-V					
TTL – MOS Dual 2-Input w/Expander	9624	5.0	0 – 30	-0.5	+0.2	120	40	7-32
MOS – TTL Dual Buffer	9625	5.0	0 – 30	+0.4	+2.6	70	60	7-32
*HLL – TTL Hex-Inverter	9109	12–20	0	2.4–5.5	0.4	120	380	**
TTL – *HLL Hex-Inverter	9112	12–20	0	10–18		90	440	**

*HLL = HIGH Level Logic

** For Data Sheet write FSC, P.O. Box 880A, Mt. View, California 94040

SELECTOR GUIDE/FUNCTIONAL INDEX

MSI ARITHMETIC OPERATORS ADDERS, A.L.U.'S, COMPARATORS, MULTIPLIERS

Function	Type No.	Description	Number of Bits	t _{pd} ns	Power Dissipation mW	Page No.
Addition	9380	Single 1-Bit Full Adder	1	47	105	8-215
	9304	Dual 1-Bit Full Adder	1	26	150	8-24
	93H183	Dual 1-Bit Full Adder	1	12	250	8-288
	9382	Single 2-Bit Full Adder	2	38	176	8-221
	9383	Single 4-Bit Full Adder	4	39	390	8-225
Arithmetic Logic Units	9340	ALU with Internal CLA	4	24	400	8-148
	9341	ALU with External CLA	4	24	450	8-153
	93S41	ALU with External CLA	4	11	500	8-158
CLA Carry Look-Ahead	9342	For Use with 9341		12	180	8-163
	93S42	For Use with 93S41		7	260	8-167
Multiplication	9344	Binary Full Multiplier	4 x 2	30	550	8-168
Compare	9324	Magnitude Comparator	5	20	210	8-124
	93L24	Magnitude Comparator	5	55	55	8-128
	9386	Identity Comparator (Quad EX-NOR)	4	18	170	8-230
Parity	9348	Parity Checker/Generator	12	40	270	8-177
	93S62	Parity Checker/Generator	9	16	350	8-206
True/Complement Generation	93H87	True/Complement, Zero/One Element	4	14	270	8-232

MSI COUNTERS

Function	Type No.	Parallel Load	Count Enable	Clock Transitions	Async. Clear	Count Rate MHz	t _{pd} ns	Power Dissipation mW	Page No.
Variable Modulo	9305			L-H	L	26	55	195	8-28
	93S05			L-H	L	100	25	400	8-33
Decade Synchronous	9310	S	H	L-H	L	45	15	325	8-54
	93L10	S	H	L-H	L	20	25	75	8-60
	93S10	S	H	L-H	L	90	8	400	8-65
Decade Asynchronous	9350			H-L	H	18	60	160	8-180
	9390			H-L	H	18	60	160	8-236
	93176	A		H-L	L	25	30	185	8-282
	93196	A		H-L	L	70	28	250	8-297
Decade Up/Down	9360	A		L-H	H	30	30	300	8-203
	93190	A	L	L-H		25	37	325	8-292
Binary Synchronous	9316	S	H	L-H	L	45	15	325	8-54
	93L16	S	H	L-H	L	20	25	75	8-60
	93S16	S	H	L-H	L	90	8	400	8-65
Binary Asynchronous	9356			H-L	H	18	75	160	8-188
	9393			H-L	H	18	75	160	8-248
	93177	A		H-L	L	25	30	185	8-282
	93197	A		H-L	L	70	42	250	8-297
Binary Up/Down	9366	A		L-H	H	30	30	300	8-203
	93191	A	L	L-H		25	37	325	8-292
Divide by 12	9392			H-L	H	18	60	160	8-244

S = Synchronous
A = Asynchronous

SELECTOR GUIDE/FUNCTIONAL INDEX

MSI DECODERS/DEMULTIPLEXERS

Function	Type No.	Active LOW Outputs No.	Separate Enable	Wired-OR Capability	Select Delay ns	Enable Delay ns	Power Dissipation mW	Page No.
Dual 1-of-4 (BCD)	9321	2 x 4	x		22	17	150	8-111
	93L21	2 x 4	x		50	38	45	8-114
1-of-8	9301	8	x		22	22	145	8-15
	9334	8*	x		22	19	280	8-138
	9302	8	x	x	30	30	145	8-21
1-of-10 (BCD)	9301	10			22		145	8-15
	93L01	10			63		45	8-18
	9302	10		x	30		145	8-21
	9345	10		x	50		215	8-173
	9352	10			24		140	8-183
1-of-10 (Excess 3)	9353	10			24		140	8-183
	9354	10			24		140	8-183
1-of-16	9311	16	x		21	17	175	8-66
	93L11	16	x		70	48	58	8-69
Programmable	93402	4**	x	x	25	25	500	9-6

*9334 is an 8-Bit addressable latch which can be used as an active HIGH decoder or demultiplexer.

**93402 is a 4x4 content addressable memory which can also be used as a programmable decoder.

MSI DISPLAY DECODER/DRIVERS

Function	Type No.	Output Sink mA	Output Voltage V	Pull-Up Resistors	Ripple Blanking	Blanking Above BCD 9 Input	Power Dissipation mW	Page No.
1-of-10 (Cold Cathode)	9315	7	55				100	8-95
	93141	7	55			x	105	8-261
1-of-10 (Incandescent, Relays Actuators)	9302	16	5			x	215	8-21
	9345	80	30			x	215	8-173
	93145	80	15			x	215	8-173
7-Segment (Decoder)	9307	11	5	x	x		165	8-34
	9358	8	5	x	x		265	8-197
	9359	9.6	5				167	8-197
7-Segment (Incandescent or LED)	9317B	40	20		x	x	220	8-98
	9317C	20	30		x	x	220	8-98
	9357A	20	30		x		265	8-191
	9357B	20	15		x		265	8-191

7-SEGMENT DECODING FORMATS

9307

0	1	2	3	4	5	6	7	8	9	10	11	12	13	14	15
0	1	2	3	4	5	6	7	8	9	0	1	2	3	4	5

9317

0	1	2	3	4	5	6	7	8	9	10	11	12	13	14	15
0	1	2	3	4	5	6	7	8	9						

9357A, 9357B, 9358 and 9359

0	1	2	3	4	5	6	7	8	9	10	11	12	13	14	15
0	1	2	3	4	5	6	7	8	9	0	1	2	3	4	5

SELECTOR GUIDE/FUNCTIONAL INDEX

MSI ENCODERS

Function	Type No.	Description	t _{pd} ns	Power Dissipation mW	Page No.
Encoders	9318	8-Input Priority Encoder	25	250	8-103
	93L18	8-Input Priority Encoder	55	70	8-107

MSI LATCHES

Function	Type No.	R-S Input	D Input	Enable Active	Clear	Reset	t _{pd} Enable ns	t _{pd} Data ns	Power Dissipation mW	Page No.
4-Bit	9314	x	x	L	x	x	20	10	175	8-85
	93L14	x	x	L	x	x	70	45	50	8-90
	9375		x	H			16	16	160	8-211
	9377		x	H			16	16	160	8-211
Dual 4-Bit	9308		x	L	x	x	20	15	340	8-38
	93L08		x	L	x	x	65	50	90	8-43
Addressable 8-Bit	9334*		x	L	x	x	20	30	280	8-138

* Addressable latch with single D-Input and three address lines.

MEMORIES

Function	Type No.	Organization		Decoding Scheme	Wired-OR Output	Address Access ns	Chip Select Access ns	Power Per Bit mW	Page No.
		Words	Bits						
16-Bit RAM	93407	16	1	1-of-4/1-of-4	x	15		20	9-23
	93433	16	1	Coincident Select	x	15		20	9-23
64-Bit RAM	93403	16	4	Full	x	40	40	8	9-10
	93435	16	4	1-of-16 Select	x	20	20	8	9-38
256-Bit RAM	93400	256	1	3-of-6/3-of-6	x	70	70	2	9-1
	93410	256	1	Full	x	30	20	1.8	9-27
1024-Bit RAM	93415	1024	1	Full	x	75	40	0.5	9-32
256-Bit ROM	93434	32	8	Full	x	40	40	2	9-35
1024-Bit ROM	93406	256	4	Full	x	40	30	0.7	9-13
8-Bit Multiple Port	9338	8	1	Full		25		50	8-142
	93S39	8	1	Full		12		60	8-147
16-Bit Associative	93402	4	4	Linear Select	x	20		25	9-6

SELECTOR GUIDE/FUNCTIONAL INDEX

MSI MULTIPLEXERS

Function	Type No.	Enable Input	Complementary Output	Wired-OR Capability	Data Z Delay	Data \bar{Z} Delay	Select Delay	Enable Delay	Power Dissipation	Page No.
					ns	ns	ns	ns	mW	
Quad 2-Input	9322	x			10		19	15	125	8-117
	93L22	x			44		38	30	45	8-121
Dual 4-Input	9309		x		17	9	24		150	8-47
	93L09		x		34	18	48		40	8-51
	93153	x			15		22	19	180	8-272
Single 8-Input	9312	x	x		19	9	24	14	135	8-72
	93L12	x	x		80	18	48	28	34	8-76
	93S12	x	x		8	5	12	7	250	8-79
	9313	x	x	x	26	20	30	25	135	8-80
	93151	x	x		18	10	28	18	150	8-265
	93152					10	28		130	8-265
Single 16-Input	93150	x				10	28	18	200	8-265

MSI REGISTERS

Function	Type No.	No. Bits	Serial Data Input	Parallel Data Input	Reset Active	Clock Enable	Shift Frequency	Clock to Output	Power Dissipation	Page No.
							MHz	ns	mW	
General Purpose	9300	4	J-K	S	L		35		300	8-1
	93L00	4	J-K	S	L		10	55	75	8-10
	93H00	4	J-K	S	L		55	10	375	8-6
	93S00	4	J-K	S	L		100	7	400	8-14
	93H72	4	D	S	L	x	60	10	400	8-207
	9394	4	D	A	H		15	25	175	8-252
	9395	4	D	S			36	21	250	8-254
	9396	5	D	A	L		15	25	240	8-259
	93178	4	D	S			22	25	170	8-283
	93179	4	D	S	L	x	22	25	270	8-283
Parallel-In/ Parallel-Out	93198	8	D	S	L	x	35	20	370	8-301
Serial/Parallel Converters	93164	8	D		L		20	20	180	8-276
	93165	8	D	A		x	20	20	230	8-279
Multiple Port	9338	8	D					25	265	8-142
	93S39	8	D					12	400	8-147
Serial-In	9328	16	D		L	x	25	15	300	8-131
Serial-Out	93L28	16	D		L	x	10	50	75	8-135

S = Synchronous
A = Asynchronous

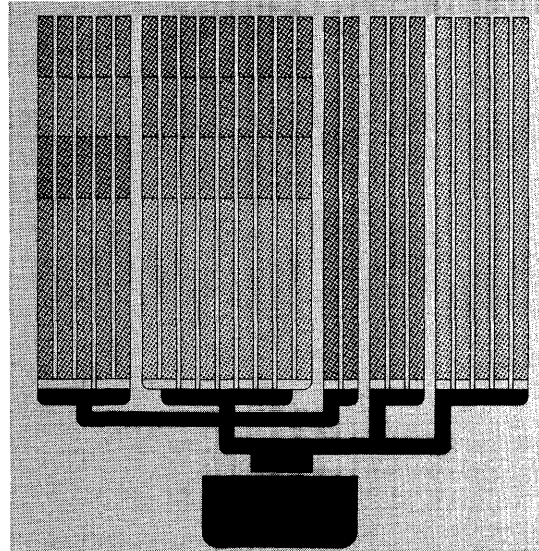

TTL Loading Rules

All devices in the Fairchild TTL family have compatible logic levels. Standard, low power and high speed device, may be mixed in a system to obtain the optimum cost, power, speed combination.

To simplify design calculations the different loading rules of each series have been normalized to one standard set of conditions.

4

5

6

7

8

9

10

11

12

TTL LOADING RULES

All Transistor Transistor Logic integrated circuits are derived from the simple gate schematic shown in Figure 1.

The output is LOW (logic "0") only if both inputs A and B are HIGH (logic "1"). This is defined as a positive logic NAND gate.

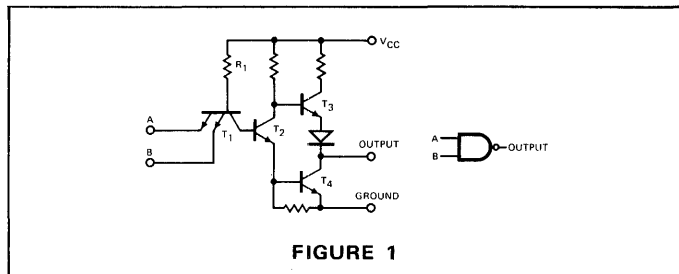

FIGURE 1

Input Characteristics

A low voltage at inputs A or B will cause current to flow out of the forward biased base-emitter diode of the multi-emitter transistor (T1). When the voltage level at A or B or both is less than $2 V_{BE(SAT)}$ levels, the current supplied by R1 will flow out of the LOW input terminal (see Figure 2) keeping transistors T2 and T4 turned off. If both inputs A and B are raised to a HIGH voltage level, the base-emitter diodes of the input transistor (T1) will be reverse biased. The current supplied by R1 will then flow through the base-collector diode of T1 (see Figure 3) turning on transistor T2 and T4. The HIGH level input voltage source must be capable of supplying leakage current to the reverse biased input transistor. Because of the NPN action of the input device, this leakage current is referred to as inverse beta current. The value of the input LOW current and input HIGH leakage current is dependent on the value of R1. The value of this resistor is chosen to optimize the specific speed/power performance characteristics of each device.

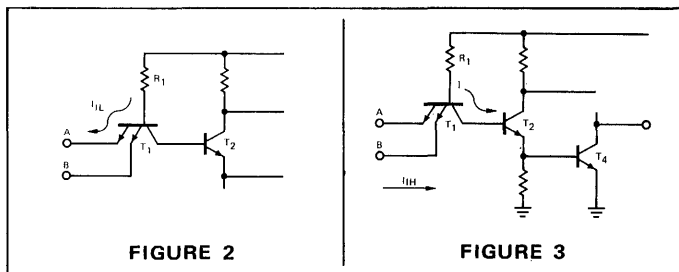

FIGURE 2

FIGURE 3

Output Characteristics

The fan out or drive capability of a TTL device reflects its ability to sink current in the output LOW (logic "0") state (see Figure 4) and to source or drive current in the output HIGH (logic "1") state (see Figure 5).

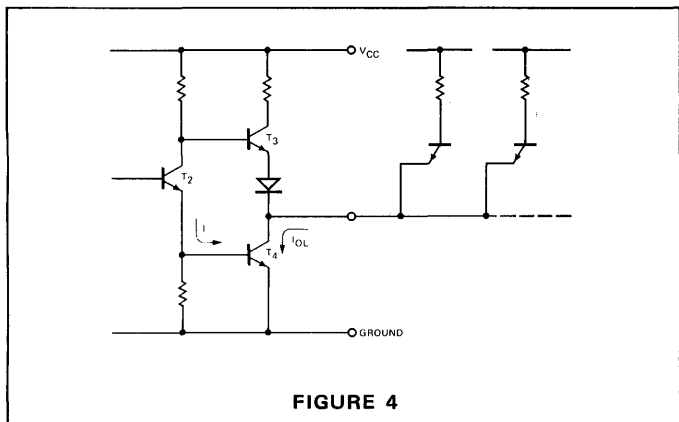

FIGURE 4

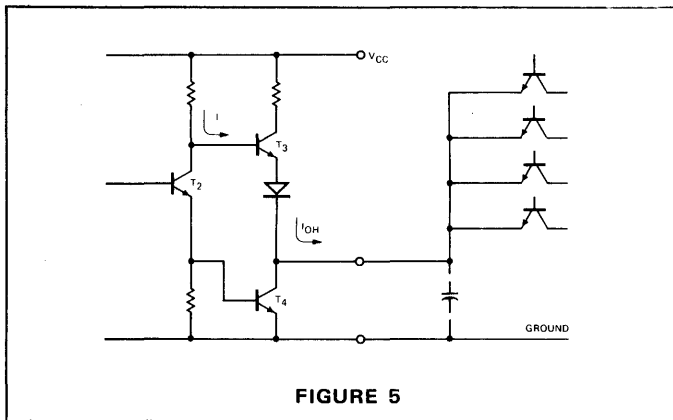

FIGURE 5

In the output LOW state the "phase splitter" transistor T2 is "on". It supplies base drive to the output pull down transistor (T4). The amount of base drive required for the pull down transistor is dependent on the worst case beta of the device and the fan out (I_{OL}) sink current requirements of the circuit. The output HIGH drive current (I_{OH}) of the device is supplied from the pull up transistor (T3). When the phase splitter transistor (T2) is turned "off", the pull up transistor is turned "on". This presents a low impedance drive source at the output. Although the static I_{OH} requirements of most circuits is less than 0.5 mA, about 35 mA is made available at the instant of LOW to HIGH output transition to charge up the distributed line, board and package capacitances encountered in most system designs. Different types of pull up circuits are used to achieve faster system speeds by minimizing HIGH output impedance and the resulting RC time constant.

Normalized Fan In/Fan Out Rules

In order to simplify designing with Fairchild TTL devices, the input and output loading parameters of all families are normalized to the following values:

1 Unit TTL Load (U.L.) = $40 \mu A$ in the HIGH state (logic "1")
= 1.6 mA in the LOW state (logic "0")

Input loading and output drive factors of all products described in this catalog are related to these definitions.

Examples – Input Load

1. A 9N00/7400 gate, which has a maximum I_{IL} of 1.6 mA and I_{IH} of $40 \mu A$ is specified as having an input load factor of 1 U.L. (Also called a fan in of 1 load.)
2. The 93H72, which has a value of $I_{IL} = 3.2 \text{ mA}$ and I_{IH} of $80 \mu A$ on the CP terminal, is specified as having an input load factor of $\frac{3.2 \text{ mA}}{1.6 \text{ mA}}$ or 2 U.L.

Examples – Output Drive

1. The output of the 9N00/7400 will sink 16 mA in the LOW (logic "0") state and source $800 \mu A$ in the HIGH (logic "1") state. The normalized output LOW drive factor is therefore $\frac{16 \text{ mA}}{1.6 \text{ mA}} = 10 \text{ U.L.}$ and the output HIGH drive factor is $\frac{800 \mu A}{40 \mu A} = 20 \text{ U.L.}$

Relative load and drive factors for the basic TTL gate families specified in this catalog are given in Table 1.

Table I

FAMILY	INPUT LOAD		OUTPUT DRIVE	
	HIGH	LOW	HIGH	LOW
9000	1 U.L.	1 U.L.	20 U.L.	10 U.L.
9H00/74H00	1.25 U.L.	1.25 U.L.	25 U.L.	12.5 U.L.
9L00	0.5 U.L.	0.25 U.L.	10 U.L.	2.5 U.L.
9N00/7400	1 U.L.	1 U.L.	20 U.L.	10 U.L.
9S00/74S00	1.25 U.L.	1.25 U.L.	25 U.L.	12.5 U.L.

Values for MSI devices vary significantly from one element to another. Consult the appropriate data sheet for actual characteristics.

DC Noise Margin

The loading rules defined above have been determined under test conditions chosen to insure useful worst case noise margin values over the full temperature and supply voltage ranges specified for the Fairchild TTL families.

Noise margin is defined in Figure 6 as the difference between the worst case output logic voltage and the worst case input voltage which guarantees the desired output level.

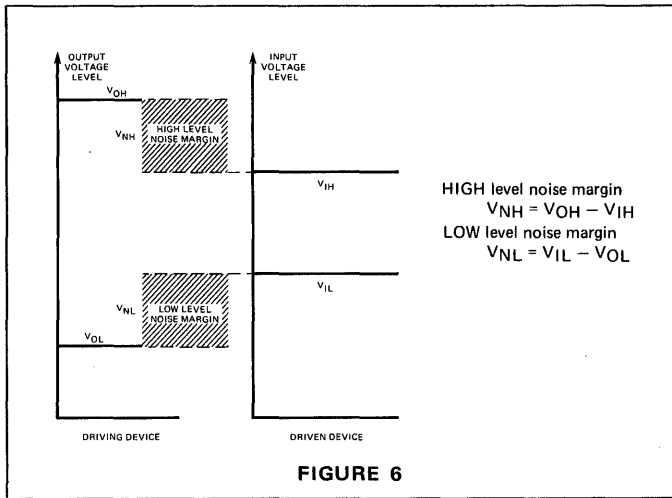

Table II below lists the worst case dc logic levels for Fairchild TTL devices.

Table II

PARAMETER	DEFINITION	9300 9N/54, 74 9H/54H, 74H	93L00 9L00	93S00 9S/74S	9S/54S
VOH	Minimum Output Voltage in the HIGH State	2.4 V	2.4 V	2.5 V	2.7 V
VOL	Maximum Output Voltage in the LOW State	0.4 V	0.3 V	0.5 V	0.5 V
VIH	Minimum Voltage Level Which is Guaranteed to be Interpreted as a HIGH at the Input	2.0 V	2.0 V	2.0 V	2.0 V
VIL	Maximum Voltage Level Which is Guaranteed to be Interpreted as a LOW at the Input	0.8 V	0.7 V	0.8 V	0.8 V

Example

- The worst case guaranteed dc noise margin for a 9300 MSI interfacing with another 9300 MSI is therefore:

$$V_{NH} = 2.4 - 2.0 = 400 \text{ mV}$$

$$V_{NL} = 0.8 - 0.4 = 400 \text{ mV}$$

- The worst case guaranteed noise margin for a 74S00 gate driving a 7400 gate is therefore:

$$V_{NH} = 2.7 - 2.0 = 700 \text{ mV}$$

$$V_{NL} = 0.8 - 0.5 = 300 \text{ mV}$$

Wired-OR Applications

Certain TTL devices are provided with an "open" collector output to permit the Wired-OR (actually Wired-AND) function. This is achieved by connecting open collector outputs together and adding an external pull up resistor.

The value of the pull up resistor is determined by considering the fan out of the OR tie and the number of devices in the OR tie. The pull up resistor value is chosen from a range between a maximum value (established to maintain the required VOH with all the OR tied outputs HIGH) and a minimum value (established so that the OR tie fan out is not exceeded when only one output is LOW).

Minimum and Maximum Pull Up Values

$$R_X (\text{Min.}) = \frac{V_{CC} (\text{max.}) - V_{OL}}{I_{OL} - N_2 I_{IL}}$$

$$R_X (\text{Max.}) = \frac{V_{CC} (\text{min.}) - V_{OH}}{N_1 I_{CEX} + N_2 I_{IH}}$$

Where

- R_X = External Pull Up Resistor
- N₁ = Number of Wired-OR Outputs
- N₂ = Number of Input Unit Loads Being Driven
- I_{CEX}(I_{OH}) = Output HIGH Leakage Current
- I_{OL} = LOW Level Fan Out Current of Driving Element
- I_{IH} = Input HIGH U.L. (40 μA)
- I_{IL} = Input LOW U.L. (1.6 mA)
- V_{OL} = Output LOW Voltage Level (0.4 V)
- V_{OH} = Output HIGH Voltage Level (2.4 V)
- V_{CC} = Power Supply Voltage

Example: Four 9N01/7401 gates driving four other gate or MSI inputs.

$$N_1 = 4$$

$$N_2 = 4 (\text{U.L.})$$

$$I_{CEX} = 250 \mu\text{A}$$

$$I_{OL} = 16 \text{ mA}$$

$$I_{IH} = 40 \mu\text{A}$$

$$I_{IL} = 1.6 \text{ mA}$$

$$V_{OL} = 0.4 \text{ V}$$

$$V_{OH} = 2.4 \text{ V}$$

$$R_X (\text{min.}) = \frac{5.25 \text{ V} - 0.4 \text{ V}}{16 \text{ mA} - 4(1.6 \text{ mA})} = \frac{4.85 \text{ V}}{9.6 \text{ mA}} \geq 505 \Omega$$

$$R_X (\text{max.}) = \frac{4.75 \text{ V} - 2.4 \text{ V}}{4(0.250 \text{ mA}) + (0.04 \text{ mA})} = \frac{2.35 \text{ V}}{1.16 \text{ mA}} \leq 2.03 \text{ k}\Omega$$

Unused Inputs

To minimize noise sensitivity and optimize switching times, unused inputs of all TTL circuits should be held between 2.4 V and the absolute maximum 5.5 V. This eliminates the effect of the distributed capacitance associated with the floating input, and ensures that no degradation will occur in the propagation delay times.

Possible ways of handling unused inputs are:

- Connect unused inputs to a μsd input if maximum HIGH level fan out of the driving output will not be exceeded. Each additional input presents a full load to the driving output at a HIGH level voltage but adds no loading at a LOW level voltage. The HIGH level fan out for all circuits has been specified at double the LOW level fan out specifically to provide for this method of treating unused inputs.
- Connect unused inputs to V_{CC} through a 1 kΩ resistor. If a transient exceeding the 5.5 V maximum rating should occur, the impedance will be high enough to protect the input. One to 25 unused inputs may be connected to each 1 kΩ resistor.
- Tie the inputs to the output of an unused gate in the system. The gate must provide a constant HIGH level output.
- Connect unused inputs to an independent supply voltage in the range of 2.4 V to 3.5 V.

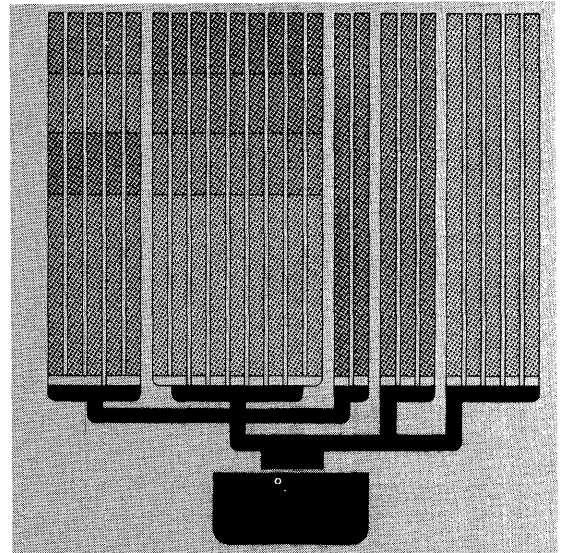

**SSI
9000, 9H(54/74H), 9L,
9N(54/74) and 9S(54/74S)
Series Data Sheets**

This section comprises data sheets on the five basic Fairchild TTL/SSI series.

9000
9H00/54H, 74H00
9L00
9N00/54, 7400
9S00/54S, 74S00

Devices are presented in alpha-numerical sequence, with the exception of the 9000 elements. All 9000 series functions are grouped together at the beginning of this section.

TTL/SSI INTRODUCTION

INTRODUCTION – The Fairchild TTL/SSI line offers the designer a broad selection of gates and flip-flops for use with Fairchild MSI, Interface and Memory products in implementing TTL system designs. These TTL/SSI functions are available for use in military and industrial temperature range applications. These products are available in the popular Dual In-Line package as well as flat packages. All Fairchild TTL products are logic and supply voltage compatible so that circuit families may be mixed within a system for optimum speed, power and economy.

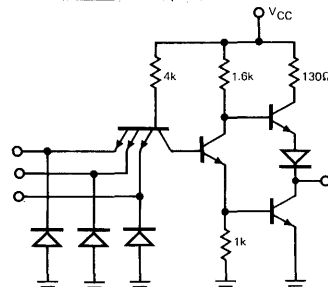
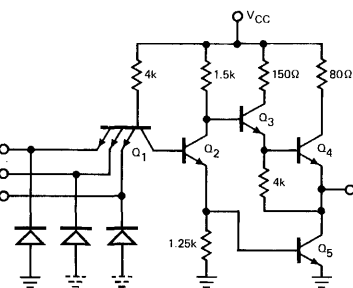
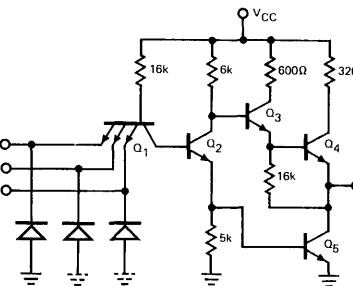
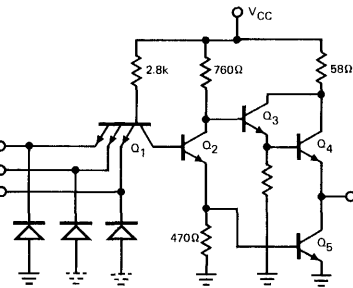
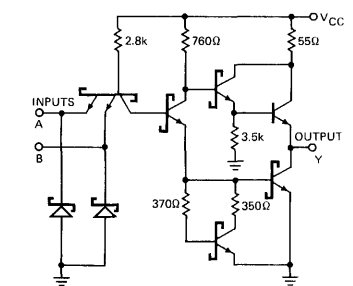
<p>9N/54, 74 SERIES TTL/SSI</p> <p>FEATURES</p> <ul style="list-style-type: none"> • 10 ns Typical Gate Delay • 10 mW Typical Gate Power Dissipation • Input Clamp Diodes Minimize Termination Effects • Military and Industrial Temperature Range • Available in DIP and Flat Packages 	<p>DESCRIPTION</p> <p>The 9N/54, 74 Series is a broad family of SSI devices which are pin and function identical with the popular 7400 series. These gates and binaries are available in industrial and military temperature ranges in both DIP and Flat packages. The line included NAND gates, NOR gates, Exclusive-OR gates, AND gates, open collector gates as well as single and dual flip-flops.</p> 
<p>9000 SERIES TTL/SSI</p> <p>FEATURES</p> <ul style="list-style-type: none"> • 8 ns Typical Gate Delay • 10 mW Typical Gate Power Dissipation • Input Clamp Diodes Reduce Termination Effects • Darlington Output Stage Increases Circuit Speed • Military and Industrial Temperature Range • Available in DIP and Flat Packages 	<p>DESCRIPTION</p> <p>The 9000 Series of gates and flip-flops offers a family of high speed functions with speed and power specifications in between the 9N/54, 74 Series and the 9H/54H, 74H Series. The Darlington output stage provides faster switching times and increased capacitive drive capability over the 9N/54, 74 Series.</p> 
<p>9L SERIES LPTTL/SSI</p> <p>FEATURES</p> <ul style="list-style-type: none"> • 20 ns Typical Gate Delay • 2 mW Typical Gate Power Dissipation • Input Clamp Diodes Minimize Termination Effects • Darlington Output Stage Increases Circuit Speed • Military and Industrial Temperature Range • Available in DIP and Flat Packages 	<p>DESCRIPTION</p> <p>The 9L Series of low power TTL gates and flip-flops offers a speed/power trade-off well suited to both industrial and military applications. The power is one fourth that of a standard TTL gate and typical system speeds of up to 10 MHz are possible. The 9L Series TTL/SSI functions are used with the 93L low power TTL/MSI devices to implement low power, moderate speed systems.</p> 
<p>9H/54H, 74H SERIES HSTTL/SSI</p> <p>FEATURES</p> <ul style="list-style-type: none"> • 6 ns Typical Gate Delay • 22 mW Typical Gate Power Dissipation • Input Clamp Diodes to Minimize Termination Effects • Darlington Output State to Increase Circuit Speed • Military and Industrial Temperature Range • Available in DIP and Flat Packages • 11 Functions Available 	<p>DESCRIPTION</p> <p>The 9H/54H, 74H Series is a line of high speed gates and flip-flops which are pin and function identical with the popular 74H00 Series. These devices are used with the 9300 and 93H Series of TTL/MSI devices to substantially reduce critical path delay times and enhance overall system speeds.</p> 
<p>9S/54S, 74S SERIES TTL/SSI</p> <p>FEATURES</p> <ul style="list-style-type: none"> • 3 ns Typical Gate Delay • 125 MHz Typical Input Clock Frequency for J-K Flip-Flops • 22 mW Gate Power Dissipation • Input Clamp Diodes to Minimize Termination Effects • Low Output Impedance to Drive High Capacitive Loads 	<p>DESCRIPTION</p> <p>The 9S00 Series is a line of super high speed devices featuring Schottky-barrier diode clamping on all normally saturated devices. The result is an overall improvement in propagation delays and greatly reduced sensitivity of delay times to temperature variation. These gate and flip-flop functions can be used with Fairchild's 93S00 Series of MSI Schottky-clamped logic elements to achieve the highest possible system speeds and still maintain typical 1.0 V noise immunity.</p> 

FAIRCHILD SERIES TTL/SSI

ABSOLUTE MAXIMUM RATINGS (above which the useful life may be impaired)

Storage Temperature	-65°C to +150°C
Temperature (Ambient) Under Bias	-55°C to +125°C
V _{CC} Pin Potential to Ground Pin	-0.5 V to +7.0 V
*Input Voltage (dc)	-0.5 V to +5.5 V
*Input Current (dc)	-30 mA to +5.0 mA
Voltage Applied to Outputs (Output HIGH)	0.5 V to +V _{CC}
Output Current (dc) (Output LOW)	
9N/54,74 and 9L Series	+30 mA
9000, 9H and 9S Series	+50 mA
See Detail Data Sheets for Buffer Drive Capability.	

*Either Input Voltage limit or Input Current limit is sufficient to protect the inputs.

INPUT AND OUTPUT LOAD FACTORS FOR THE 9000 SERIES GATES & FLIP-FLOPS

The test conditions and resulting limits for the input and output levels of the 9000 Series gates and flip-flops differs from the other 9N, 9H, 9L, and 9S series of devices. These 9000 Series levels and conditions are equivalent to the other families for all practical purposes. For instance, an input HIGH level current guaranteed to be 60 μ A when measured at 4.5 V, will be less than 40 μ A for most operating conditions. Therefore, the load factors for the 9000 Series has been normalized to simplify system design considerations.

NAND GATES – 9002, 9003, 9004, 9007 AND 9012* HEX INVERTER – 9016 AND 9017*

The 9002, 9003, 9004, 9007 and 9012 are active LOW level output AND gates commonly known as NAND gates. The 9016 and 9017 are hex inverters with input and output characteristics identical to NAND gate. The variety of gate combinations provides the system designer the utmost in logic flexibility and reduces package count.

LOGIC SYMBOL AND PIN CONFIGURATIONS

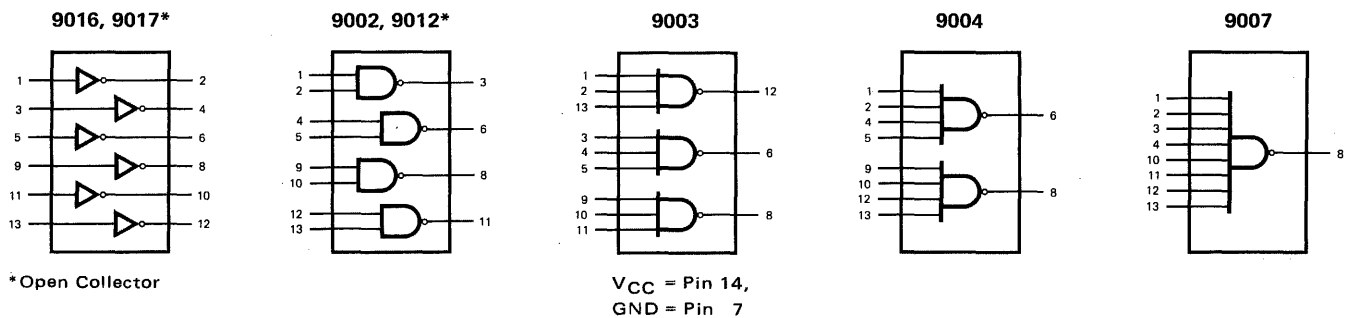

Fig. 1

TTL/SSI • 9000 SERIES

BASIC GATE CIRCUIT

Nominal Resistor Values

- $R_1 = R_5 = 4.0 \text{ k}\Omega$
- $R_2 = 1.5 \text{ k}\Omega$
- $R_3 = 150 \Omega$
- $R_4 = 80 \Omega$
- $R_6 = 1.25 \text{ k}\Omega$

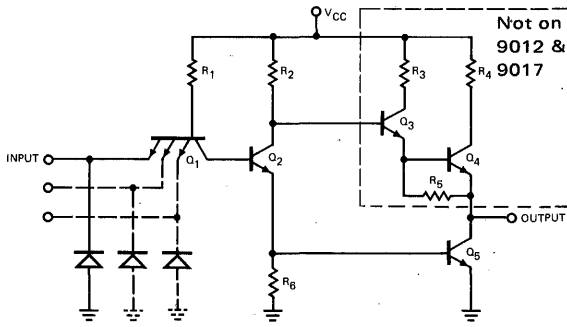

Fig. 2

LOADING FACTORS

PIN NAMES LOADING

All Inputs 1 U.L.

All Outputs 10 U.L.*

(1 U.L. = 40 μA HIGH/1.6 mA LOW)

*The 9012 & 9017 need external resistors to provide HIGH level drive.

Fig. 3

ELECTRICAL CHARACTERISTICS 9002XC, 9003XC, 9004XC, 9007XC, 9012XC, 9016XC AND 9017XC ($T_A = 0^\circ\text{C}$ to 75°C , $V_{CC} = 5.0 \text{ V} \pm 5\%$)

SYMBOL	PARAMETER	LIMITS			UNITS	TEST CONDITIONS
		0°C MIN. MAX.	25°C MIN. TYP. MAX.	75°C MIN. MAX.		
V_{IH}	Input HIGH Voltage	1.9	1.8		Volts	Guaranteed Input HIGH Threshold Voltage for All Inputs
V_{IL}	Input LOW Voltage	0.85		0.85	Volts	Guaranteed Input LOW Threshold Voltage for All Inputs
V_{OH}	Output HIGH Voltage (except 9012, 9017)	2.4	2.4 2.9	2.4	Volts	$V_{CC} = 4.75 \text{ V}$, $I_{OH} = -1.2 \text{ mA}$, Inputs at V_{IL}
V_{OL}	Output LOW Voltage	0.45	0.21 0.45	0.45	Volts	$V_{CC} = 5.25 \text{ V}$, $I_{OL} = 16.0 \text{ mA}$, $V_{IN} = 5.25 \text{ V}$ $V_{CC} = 4.75 \text{ V}$, $I_{OL} = 14.1 \text{ mA}$, Inputs at V_{IH}
I_{IH}	Input HIGH Current		10 60	60	μA	$V_{CC} = 5.25 \text{ V}$, $V_{IN} = 4.5 \text{ V}$ GND on Other Inputs
I_{IL}	Input LOW Current	-1.6 -1.41	-1.0 -1.6 -0.91 -1.41	-1.6 -1.41	mA	$V_{CC} = 5.25 \text{ V}$ $V_{IN} = 0.45 \text{ V}$ $V_{CC} = 4.75 \text{ V}$ 5.25 V on Other Inputs
I_{CEX}	Output Reverse Current 9012, 9017 only		2.0 250	250	μA	$V_{CC} = 4.75 \text{ V}$, $V_{IN} = V_{IL}$, $V_{OUT} = 5.5 \text{ V}$
I_{CC}	V_{CC} Current, Gate On (each gate) V_{CC} Current, Gate Off (each gate)	6.1 1.7	3.6 6.1 1.07 1.7	6.1 1.7	mA	Inputs HIGH Inputs at GND $V_{CC} = 5.0 \text{ V}$
t_{PLH}	Turn OFF Delay Input to Output		3.0 13		ns	$V_{CC} = 5.0 \text{ V}$, $C_L = 15 \text{ pF}$ See Fig. 12
	9012, 9017 only		3.0 45			
t_{PHL}	Turn ON Delay Input to Output		3.0 15		ns	$R_L = 400 \Omega$
	9012, 9017 only		3.0 15			

ELECTRICAL CHARACTERISTICS 9002XM, 9003XM, 9004XM, 9007XM, 9012XM, 9016XM, AND 9017XM ($T_A = -55^\circ\text{C}$ to $+125^\circ\text{C}$, $V_{CC} = 5.0 \text{ V} \pm 10\%$)

SYMBOL	PARAMETER	LIMITS			UNITS	TEST CONDITIONS
		-55°C MIN. MAX.	25°C MIN. TYP. MAX.	125°C MIN. MAX.		
V_{IH}	Input HIGH Voltage	2.0	1.7		Volts	Guaranteed Input HIGH Threshold Voltage for All Inputs
V_{IL}	Input LOW Voltage	0.8		0.9	Volts	Guaranteed Input LOW Threshold Voltage for All Inputs
V_{OH}	Output HIGH Voltage (except 9012, 9017)	2.4	2.4 2.7	2.4	Volts	$V_{CC} = 4.5 \text{ V}$, $I_{OH} = -1.32 \text{ mA}$, Inputs at V_{IL}
V_{OL}	Output LOW Voltage	0.4	0.21 0.4	0.4	Volts	$V_{CC} = 5.5 \text{ V}$, $I_{OL} = 17.6 \text{ mA}$, $V_{IN} = 5.5 \text{ V}$ $V_{CC} = 4.5 \text{ V}$, $I_{OL} = 13.6 \text{ mA}$, Inputs at V_{IH}
I_{IH}	Input HIGH Current		10 60	60	μA	$V_{CC} = 5.5 \text{ V}$, $V_{IN} = 4.5 \text{ V}$ GND on Other Inputs
I_{IL}	Input LOW Current	-1.6 -1.24	-1.1 -1.6 -0.87 -1.24	-1.6 -1.24	mA	$V_{CC} = 5.5 \text{ V}$ $V_{IN} = 0.4 \text{ V}$ $V_{CC} = 4.5 \text{ V}$ 5.5 V on Other Inputs
I_{CEX}	Output Reverse Current 9012, 9017 only		2.0 250	250	μA	$V_{CC} = 4.5 \text{ V}$, $V_{IN} = V_{IL}$, $V_{OUT} = 5.5 \text{ V}$
I_{CC}	V_{CC} Current, Gate On (each gate) V_{CC} Current, Gate Off (each gate)	5.5 1.6	3.5 5.5 1.07 1.6	5.5 1.6	mA	Inputs HIGH Inputs at GND $V_{CC} = 5.0 \text{ V}$
t_{PLH}	Turn OFF Delay Input to Output		3.0 10		ns	$V_{CC} = 5.0 \text{ V}$ $C_L = 15 \text{ pF}$ See Fig. 12
	9012, 9017 only		3.0 45			
t_{PHL}	Turn ON Delay Input to Output		3.0 12		ns	$R_L = 400 \Omega$
	9012, 9017 only		3.0 15			

9002, 9003, 9004, 9007, 9012, 9016 AND 9017
TYPICAL INPUT AND OUTPUT CHARACTERISTICS

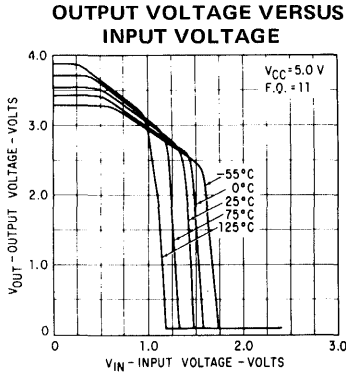

Fig. 4

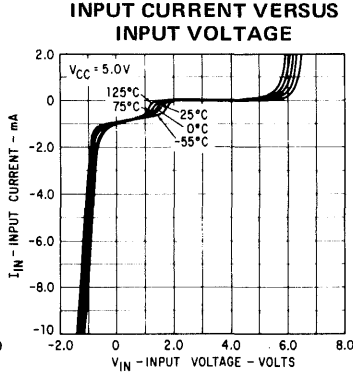

Fig. 5

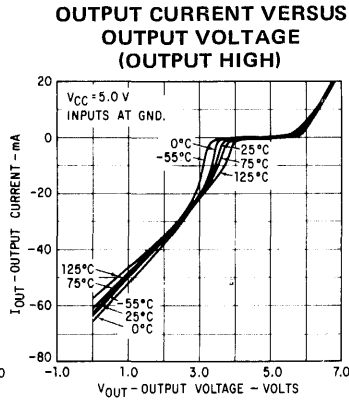

Fig. 6

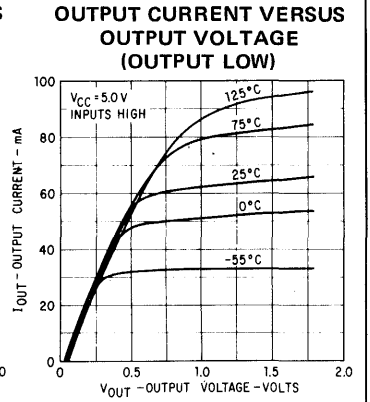

Fig. 7

POWER DISSIPATION, LOGIC LEVELS AND NOISE IMMUNITY

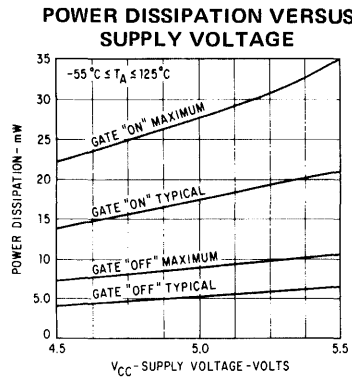

Fig. 8

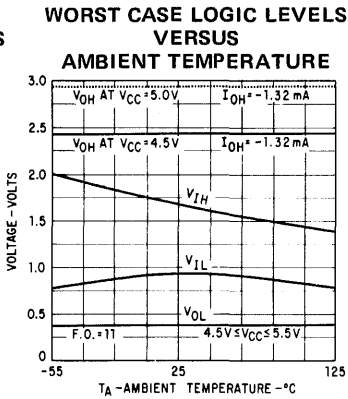

Fig. 9

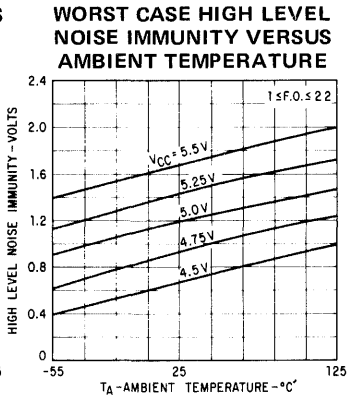

Fig. 10

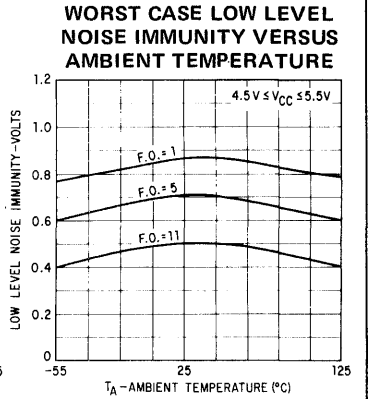

Fig. 11

SWITCHING CHARACTERISTICS

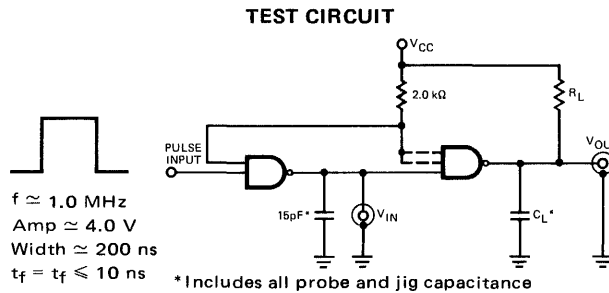

Fig. 12

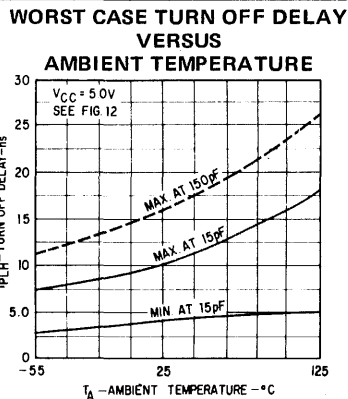
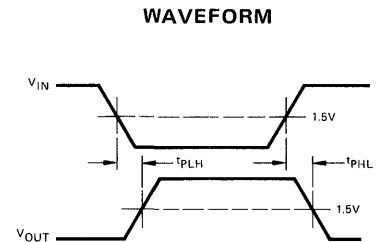

Fig. 13

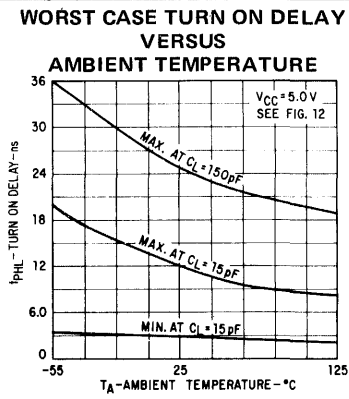

Fig. 14

**EXTENDABLE AND-OR-INVERT GATES – 9005, 9008
EXTENDER – 9006**

The TTL 9005 and 9008 are AND-OR-INVERT gates which may be OR extended with the use of the 9006. For noise immunity and operating level curves, refer to the gate section.

LOGIC DIAGRAMS

**9005
EXTENDABLE GATE**

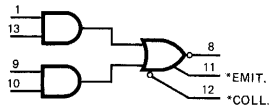

NON-EXTENDABLE GATE

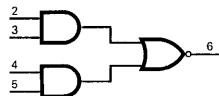

V_{CC} = Pin 14
GND = Pin 7

* Four Extenders (9006) may be tied to these terminals

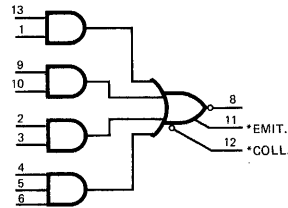

V_{CC} = Pin 14
GND = Pin 7

* Four Extenders (9006) may be tied to these terminals

9006

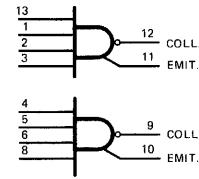

V_{CC} = Pin 14
GND = Pin 7

Fig. 1

CIRCUIT DIAGRAMS

**9005
EXTENDABLE GATE**

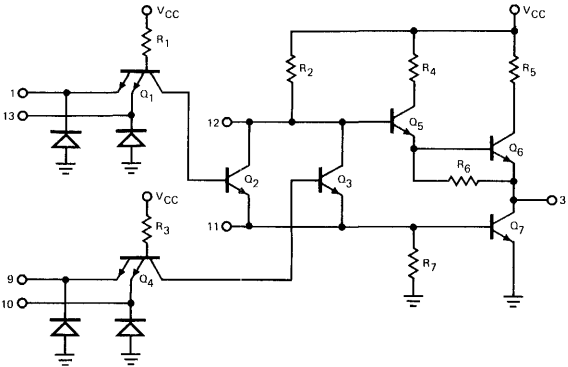

NON-EXTENDABLE GATE

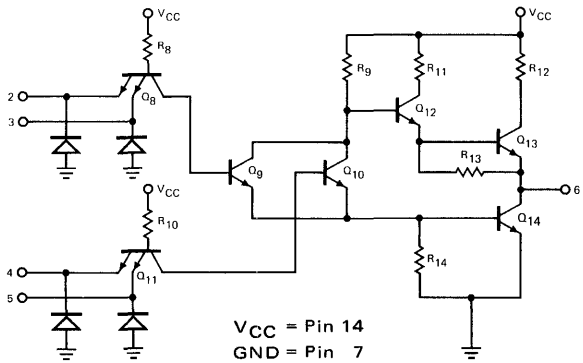

V_{CC} = Pin 14
GND = Pin 7

Typical Resistor Values

- R₁ = R₃ = 2.6 kΩ
- R₂ = 800 Ω
- R₄ = R₁₁ = 150 Ω
- R₅ = R₁₂ = 80 Ω
- R₆ = R₈ = R₁₀ = R₁₃ = 4.0 kΩ
- R₇ = 665 Ω
- R₉ = 1.5 kΩ
- R₁₄ = 1.25 kΩ

9008

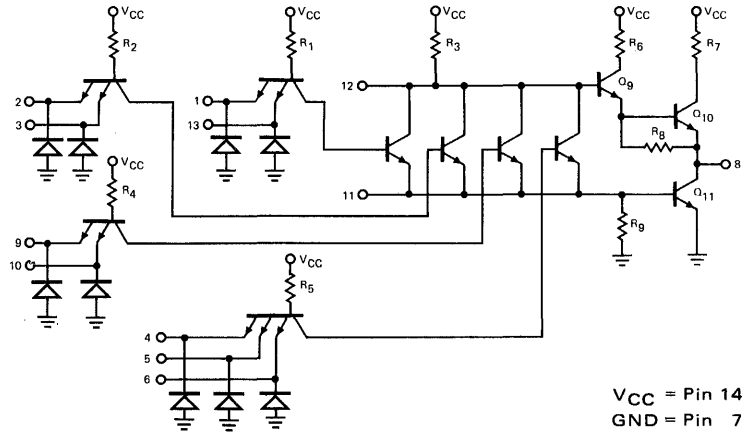

V_{CC} = Pin 14
GND = Pin 7

Typical Resistor Values

- R₁ = R₂ = R₄ = R₅ = 2.6 kΩ
- R₃ = 800 Ω
- R₆ = 150 Ω
- R₇ = 80 Ω
- R₈ = 4.0 kΩ
- R₉ = 665 Ω

9006

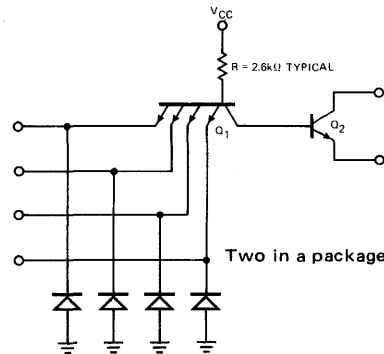

V_{CC} = Pin 14
GND = Pin 7

Fig. 2

TTL/SSI • 9000 SERIES

LOADING FACTORS

9005		9008		9006	
PIN NAMES	LOADING	PIN NAMES	LOADING	PIN NAMES	LOADING
Non-extendable Gate Inputs	1.0 U.L.	All Inputs	1.5 U.L.	All Inputs	1.5 U.L.
Extendable Gate Inputs	1.5 U.L.	Outputs	10 U.L.	Outputs	*
All Outputs	10 U.L.				

*Outputs on 9006 have open emitter and collector.

(1 U.L. = 40 μ A HIGH/1.6 mA LOW)

Fig. 3

ELECTRICAL CHARACTERISTICS 9005XC, 9006XC AND 9008XC ($T_A = 0^\circ\text{C}$ to 75°C , $V_{CC} = 5.0\text{ V} \pm 5\%$)

SYMBOL	PARAMETER	LIMITS				UNITS	TEST CONDITIONS		
		0°C		25°C				75°C	
		MIN.	MAX.	MIN.	TYP. MAX.			MIN.	MAX.
V_{IH}	Input HIGH Voltage	1.9		1.8		1.6	Volts	Guaranteed Input HIGH Threshold Voltage for All Inputs	
V_{IL}	Input LOW Voltage	0.85		0.85		0.85	Volts	Guaranteed Input LOW Threshold Voltage for All Inputs	
V_{OH}	Output HIGH Voltage	2.4		2.4	2.9	2.4	Volts	$V_{CC} = 4.75\text{ V}$, $I_{OH} = -1.2\text{ mA}$ $V_{IL} = \text{Value indicated on This Table}$	
V_{OL}	Output LOW Voltage	0.45		0.2	0.45	0.45	Volts	$V_{CC} = 5.25\text{ V}$, $I_{OL} = 16.0\text{ mA}$, $V_{IN} = 5.25\text{ V}$ $V_{CC} = 4.75\text{ V}$, $I_{OL} = 14.1\text{ mA}$, Inputs at V_{IL}	
I_{IH}	Input HIGH Current 9005 Non-Extendable Gate			5.0	60	60	μ A	$V_{IN} = 4.5\text{ V}$ $V_{CC} = 4.75\text{ V}$ GND on All Other Inputs	
	Input HIGH Current Extendable Gates and Extender			7.5	90	90			
I_{IL}	Input LOW Current 9005 Non-Extendable Gate	-1.6		-1.04	-1.6	-1.6	mA	$V_{IN} = 0.45\text{ V}$ 5.25 V on Other Inputs	
	Input LOW Current Extendable Gates and Extender	-2.4		-1.56	-2.4	-2.4			
		-2.12		-1.19	-2.12	-2.12	mA		
I_{CC}	V_{CC} Current, Gate "ON" 9005 Non-Extendable Gate	7.7		4.5	7.7	7.7	mA	$V_{CC} = 5.0\text{ V}$ All Inputs Open	
	9005 Extendable Gate	13.6		7.6	13.6	13.6			
	9008	17.7		9.3	17.7	17.7			
	V_{CC} Current, Gate "OFF" 9005 Non-Extendable Gate	3.4		2.2	3.4	3.4	mA	$V_{CC} = 5.0\text{ V}$ All Inputs Except Extender Inputs GND	
	9005 Extendable Gate	5.1		3.3	5.1	5.1			
	9008	10.2		6.6	10.2	10.2			
ΔI_{CC}	Extra Current Drain when one 9006 Extender is attached to a 9005 Gate "ON"	2.05		1.08	2.05	2.05	mA	$V_{CC} = 5.0\text{ V}$ All Inputs HIGH	
	Extra Current Drain when one 9006 Extender is attached to a 9005 Gate "OFF"	2.54		1.65	2.54	2.54			

NOTE:

Output characteristics above apply to a 9005 (both gates) or a 9008.

Input characteristics above apply to a 9005 (both gates) or a 9008 using either the internal gates or an external 9006 extender.

TTL/SSI • 9000 SERIES

ELECTRICAL CHARACTERISTICS 9005XM, 9006XM AND 9008XM ($T_A = -55^\circ\text{C}$ to 125°C , $V_{CC} = 5.0\text{ V} \pm 10\%$)

SYMBOL	PARAMETER	LIMITS			UNITS	TEST CONDITIONS			
		-55°C		25°C			125°C		
		MIN.	MAX.	MIN. TYP. MAX.	MIN. MAX.				
V_{IH}	Input HIGH Voltage	2.0		1.7		1.4	Volts	Guaranteed Input HIGH Threshold Voltage for All Inputs	
V_{IL}	Input LOW Voltage		0.8		0.9	0.8	Volts	Guaranteed Input LOW Threshold Voltage for All Inputs	
V_{OH}	Output HIGH Voltage	2.4		2.4	2.7	2.4	Volts	$V_{CC} = 4.5\text{ V}$, $I_{OH} = -1.32\text{ mA}$ $V_{IL} =$ Value Indicated on This Table	
V_{OL}	Output LOW Voltage		0.4		0.2	0.4	Volts	$V_{CC} = 5.5\text{ V}$, $I_{OL} = 17.6\text{ mA}$, $V_{IN} = 5.5\text{ V}$ $V_{CC} = 4.5\text{ V}$, $I_{OL} = 13.6\text{ mA}$, Inputs at V_{IH}	
I_{IH}	Input HIGH Current 9005 Non-extendable Gate			5.0	60	60	μA	$V_{CC} = 5.5\text{ V}$ $V_{IN} = 4.5\text{ V}$	GND on All Other Inputs
	Input HIGH Current Extendable Gate and Extender			7.5	90	90			
I_{IL}	Input LOW Current 9005 Non-extendable Gate	-1.6		-1.1	-1.6	-1.6	mA	$V_{CC} = 5.5\text{ V}$ $V_{CC} = 4.5\text{ V}$	$V_{IN} = 0.4\text{ V}$, 5.5 V on Other Inputs
	Input LOW Current Extendable Gate and Extender	-2.4		-1.5	-2.4	-2.4			
		-1.86		-1.31	-1.86	-1.86			
I_{CC}	V_{CC} Current, Gate "ON" 9005 Non-extendable Gate	6.5		4.5	6.5	6.5	mA	$V_{CC} = 5.0\text{ V}$	All Inputs Open
	9005 Extendable Gate	11.3		7.6	11.3	11.3			
	9008	12.5		9.3	12.5	12.5			
	V_{CC} Current, Gate "OFF" 9005 Non-extendable Gate	3.1		2.1	3.1	3.1			
	9005 Extendable Gate	4.7		3.3	4.7	4.7			
9008	9.4		6.6	9.4	9.4				
ΔI_{CC}	Extra Current Drain from one 9006 Extender Gate "ON"	1.61		1.08	1.61	1.61	mA	$V_{CC} = 5.0\text{ V}$, All Inputs HIGH 9006 Attached to a 9005	
	Extra Current Drain from one 9006 Extender Gate "OFF"	2.35		1.65	2.35	2.35			

NOTE:

Output characteristics apply to a 9005 (both gates) or a 9008.

Input characteristics apply to a 9005 (both gates) or a 9008 using either the internal gates or an external 9006 extender.

9005, 9006, 9008 TYPICAL INPUT-OUTPUT CHARACTERISTICS (EXTENDABLE GATES)

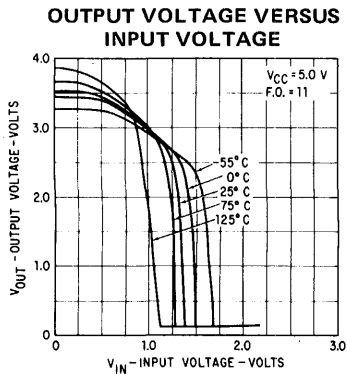

Fig. 4

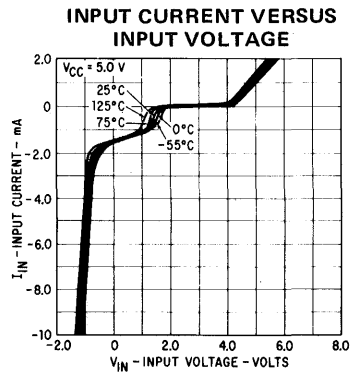

Fig. 5

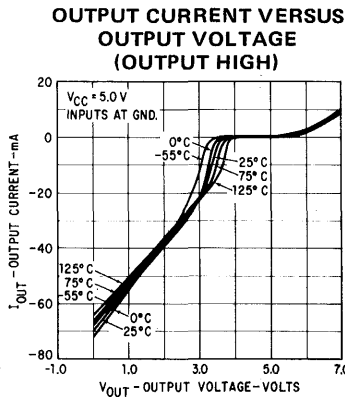

Fig. 6

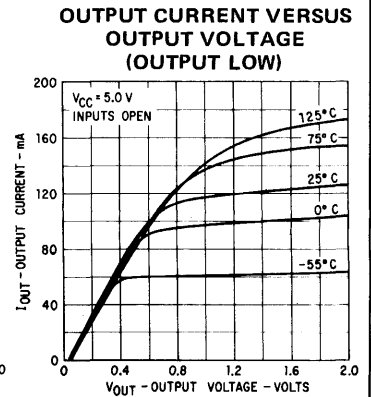

Fig. 7

SWITCHING CHARACTERISTICS

TEST CIRCUITS

9005 NON-EXTENDABLE GATE

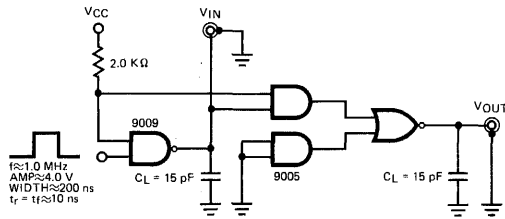

Fig. 8

9005 OR 9008 EXTENDABLE GATE

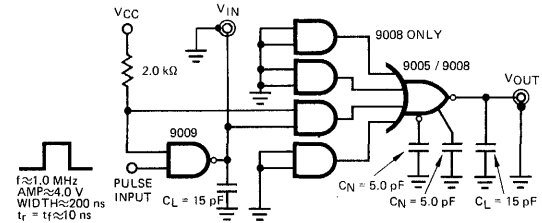
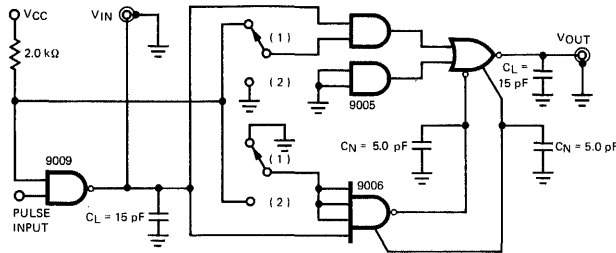

Fig. 9

Note: Capacitance includes probe and jig capacitance

9006 EXTENDER



Note: Capacitance includes probe and jig capacitance

Fig. 10

SWITCHING WAVEFORM

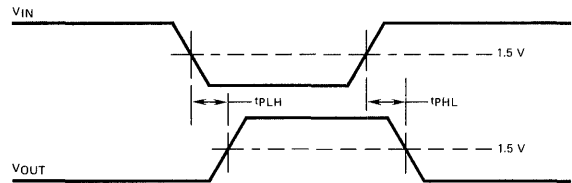

NOTES:

With switch in position (1) measure delay of 9005. With switch in position (2) measure delay (9005) + Δdelay (9006). Capacitances include probe and jig capacitances.

SWITCHING CHARACTERISTICS (TA = 25°C)

SYMBOL	LIMITS		UNITS	TEST CONDITIONS
	MIN.	MAX.		
tPLH	3.0	12	ns	VCC = 5.0 V, CL = 15 pF 9005 Non-extendable Gate Only, See Figure 8
tPHL	3.0	14		
tPLH	3.0	15	ns	VCC = 5.0 V, CL = 15 pF, CN = 5.0 pF 9005 Extendable Gate and 9008, See Figure 9
tPHL	3.0	12		
ΔtPLH	-2.0	4.0	ns	9006 Only The 9006 is tested by measuring its propagation time through the 9005. The delay readings shall not exceed the 9005 readings by the specified amount. See Figure 10.
ΔtPHL	-2.0	4.0		

Symbols are defined in the test circuit.

WORST CASE TURN OFF DELAY OF EXTENDABLE GATE VERSUS AMBIENT TEMPERATURE

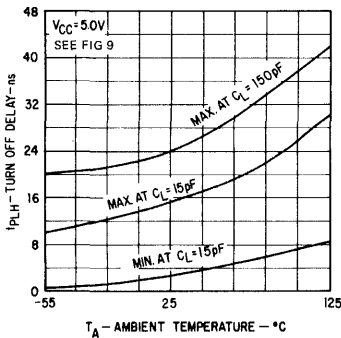

Fig. 11

WORST CASE TURN ON DELAY OF EXTENDABLE GATE VERSUS AMBIENT TEMPERATURE

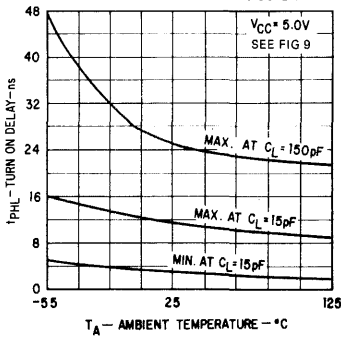

Fig. 12

WORST CASE TURN OFF DELAY OF NON-EXTENDABLE GATE VERSUS AMBIENT TEMPERATURE

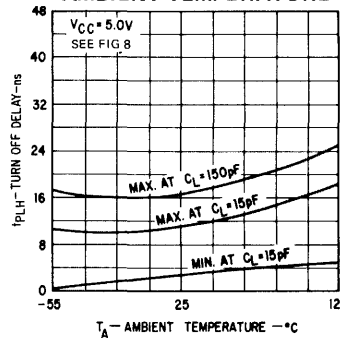

Fig. 13

WORST CASE TURN ON DELAY OF NON-EXTENDABLE GATE VERSUS AMBIENT TEMPERATURE

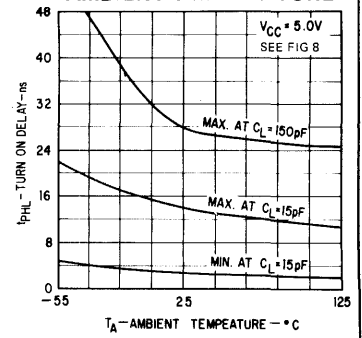

Fig. 14

TTL/SSI • 9000 SERIES

NAND BUFFER – 9009

The 9009 is a power gate capable of sinking and sourcing large currents for high fan out applications. Logically it is the same as the 9004.

LOGIC DIAGRAM AND PIN CONFIGURATION

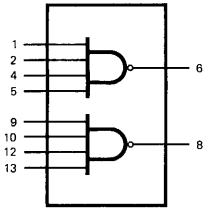

V_{CC} = Pin 14
GND = Pin 7

Fig. 1

CIRCUIT DIAGRAM (One Gate)

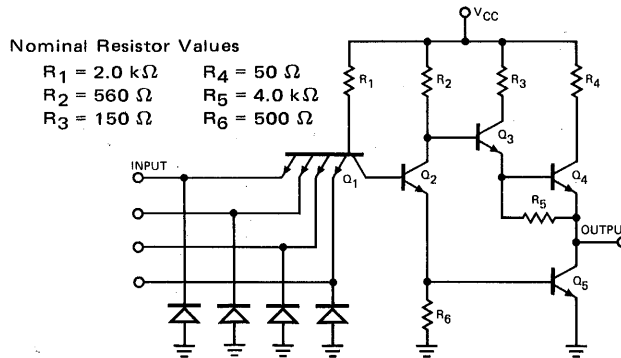

Fig. 2

LOADING FACTORS

PIN NAMES	LOADING
All Inputs	2.0 U.L.
All Outputs	30 U.L. LOW 90 U.L. HIGH

(1 U.L. = 40 μ A HIGH/1.6 mA LOW)

Fig. 3

ELECTRICAL CHARACTERISTICS 9009XC ($T_A = 0^\circ\text{C}$ to 75°C , $V_{CC} = 5.0\text{ V} \pm 5\%$)

SYMBOL	PARAMETER	LIMITS				UNITS	TEST CONDITIONS			
		0°C		25°C				75°C		
		MIN.	MAX.	MIN.	TYP.	MAX.	MIN.	MAX.		
V_{IH}	Input HIGH Voltage	1.9		1.8			1.6		Volts	Guaranteed Input HIGH Threshold Voltage for All Inputs
V_{IL}	Input LOW Voltage		0.85			0.85		0.85	Volts	Guaranteed Input LOW Threshold Voltage for All Inputs
V_{OH}	Output HIGH Voltage	2.4		2.4	2.9		2.4		Volts	$V_{CC} = 4.75\text{ V}$, $I_{OH} = -3.6\text{ mA}$, Inputs at V_{IL}
V_{OL}	Output LOW Voltage		0.45		0.21	0.45		0.45	Volts	$V_{CC} = 5.25\text{ V}$, $I_{OL} = 48.0\text{ mA}$, $V_{IN} = 5.25\text{ V}$ $V_{CC} = 4.75\text{ V}$, $I_{OL} = 42.3\text{ mA}$, Inputs at V_{IH}
I_{IH}	Input HIGH Current				20	120		120	μ A	$V_{CC} = 5.25\text{ V}$, $V_{IN} = 4.5\text{ V}$ GND on Other Inputs
I_{IL}	Input LOW Current		-3.2		-2.0	-3.2		-3.2	mA	$V_{CC} = 5.25\text{ V}$, $V_{IN} = 0.45\text{ V}$ $V_{CC} = 4.75\text{ V}$, 5.25 V on Other Inputs
I_{CC}	V_{CC} Current, Gate On (each gate)		14.6		8.6	14.6		14.6	mA	Inputs HIGH
	V_{CC} Current, Gate Off (each gate)		3.4		2.15	3.4		3.4	mA	Inputs at GND
t_{PLH}	Turn Off Delay				3.0		17		ns	$V_{CC} = 5.0\text{ V}$, See Figure 12 $C_L = 15\text{ pF}$
t_{PHL}	Turn On Delay				2.0		13		ns	

ELECTRICAL CHARACTERISTICS 9009XM ($T_A = -55^\circ\text{C}$ to 125°C , $V_{CC} = 5.0\text{ V} \pm 10\%$)

SYMBOL	PARAMETER	LIMITS				UNITS	TEST CONDITIONS			
		-55°C		25°C				125°C		
		MIN.	MAX.	MIN.	TYP.	MAX.	MIN.	MAX.		
V_{IH}	Input HIGH Voltage	2.0		1.7			1.4		Volts	Guaranteed Input HIGH Threshold Voltage for All Inputs
V_{IL}	Input LOW Voltage		0.8			0.9		0.8	Volts	Guaranteed Input LOW Threshold Voltage for All Inputs
V_{OH}	Output HIGH Voltage	2.4		2.4	2.7		2.4		Volts	$V_{CC} = 4.5\text{ V}$, $I_{OH} = -3.96\text{ mA}$, Inputs at V_{IL}
V_{OL}	Output LOW Voltage		0.4		0.21	0.4		0.4	Volts	$V_{CC} = 5.5\text{ V}$, $I_{OL} = 52.8\text{ mA}$, $V_{IN} = 5.5\text{ V}$ $V_{CC} = 4.5\text{ V}$, $I_{OL} = 40.8\text{ mA}$, Inputs at V_{IH}
I_{IH}	Input HIGH Current				20	120		120	μ A	$V_{CC} = 5.5\text{ V}$, $V_{IN} = 4.5\text{ V}$ GND on Other Inputs
I_{IL}	Input LOW Current		-3.2		-2.2	-3.2		-3.2	mA	$V_{CC} = 5.5\text{ V}$, $V_{IN} = 0.4\text{ V}$ $V_{CC} = 4.5\text{ V}$, 5.5 V on Other Inputs
I_{CC}	V_{CC} Current, Gate On (each gate)		12.9		8.6	12.9		12.9	mA	Inputs HIGH
	V_{CC} Current, Gate Off (each gate)		3.2		2.15	3.2		3.2	mA	Inputs at GND
t_{PLH}	Turn Off Delay				4.0		15		ns	$V_{CC} = 5.0\text{ V}$, See Figure 12
t_{PHL}	Turn On Delay				3.0		10		ns	$C_L = 15\text{ pF}$

9009
TYPICAL INPUT AND OUTPUT CHARACTERISTICS

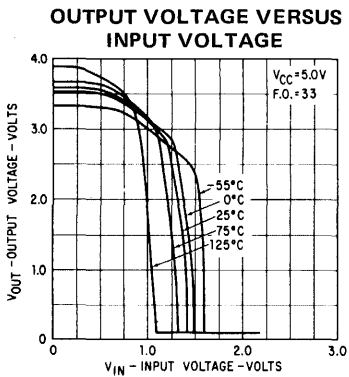

Fig. 4

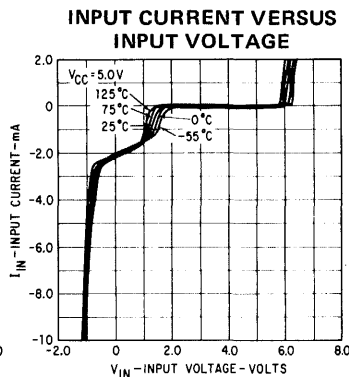

Fig. 5

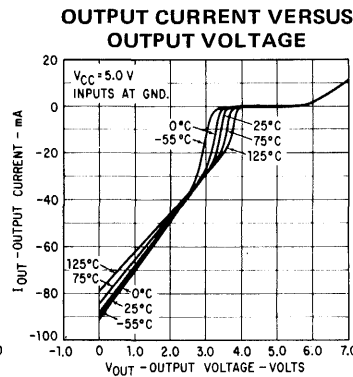

Fig. 6

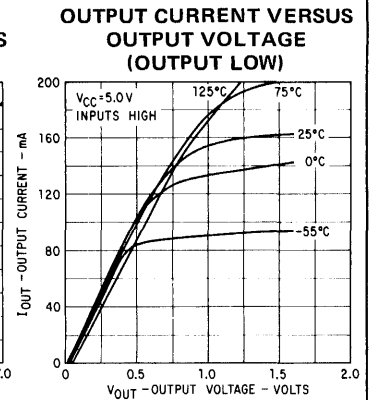

Fig. 7

POWER DISSIPATION, LOGIC LEVELS AND NOISE IMMUNITY

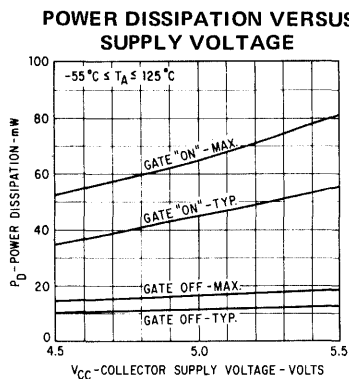

Fig. 8

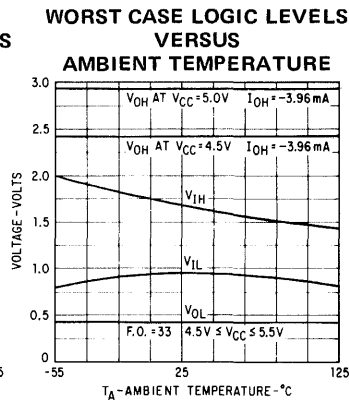

Fig. 9

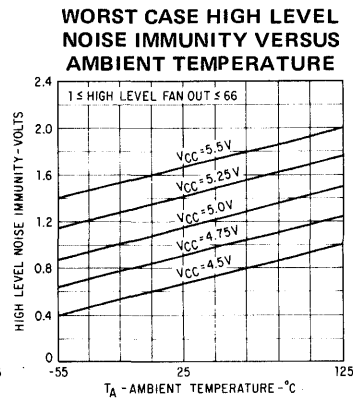

Fig. 10

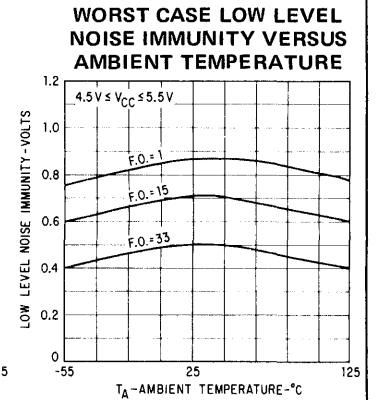

Fig. 11

SWITCHING CHARACTERISTICS

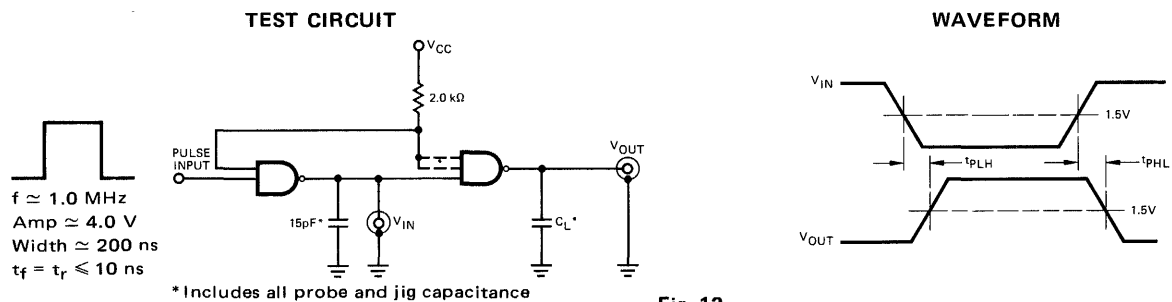

Fig. 12

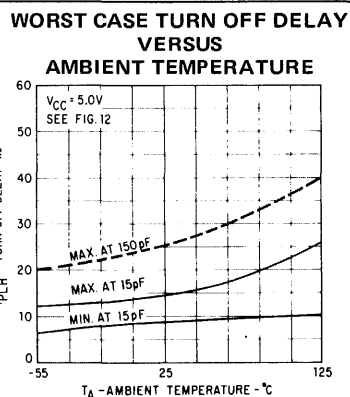

Fig. 13

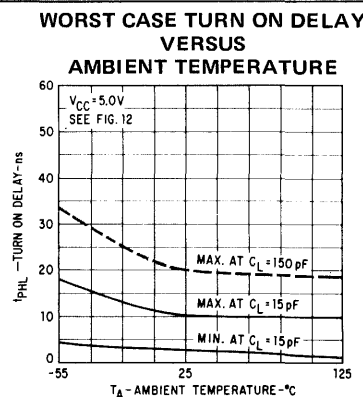
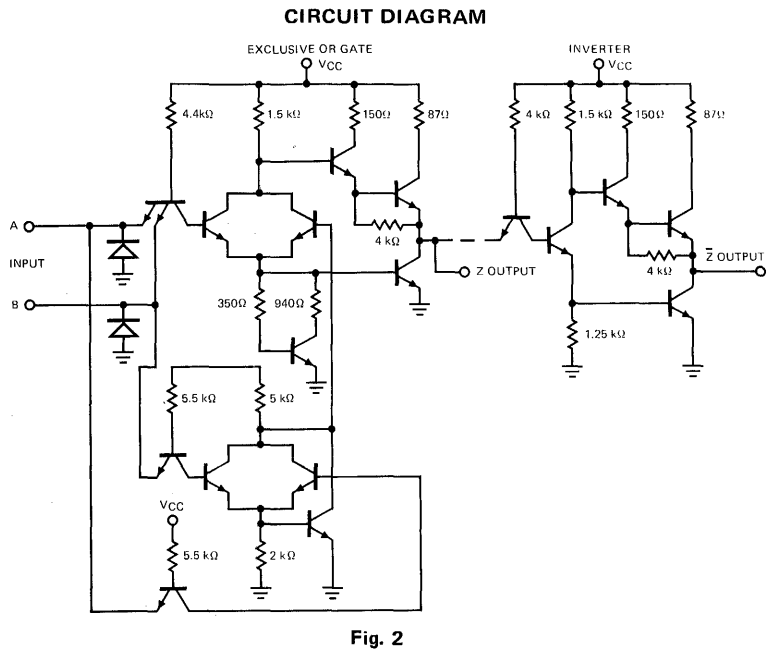
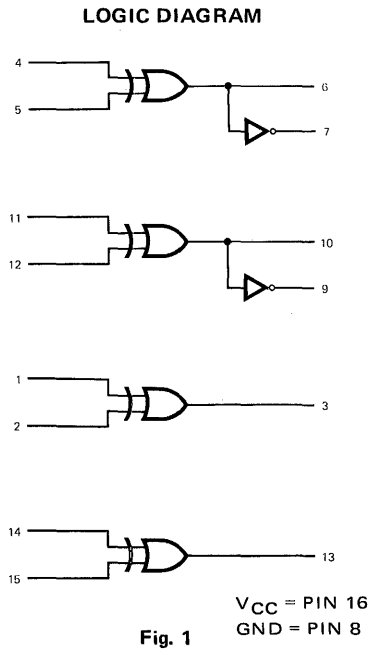

Fig. 14

QUAD EXCLUSIVE OR GATE – 9014

The 9014 consists of four exclusive OR gates, useful in a large number of code conversion, parity generation/checking, and comparison applications. Two of the gates have an additional complemented output for greater system flexibility. The 9014 has high speed, high fanout capabilities and is compatible with all members of the Fairchild TTL family.



LOADING FACTORS

PIN NAMES	LOADING (Note a)
All Inputs	1.5 U.L.
Outputs	
3, 7, 9, 13 (Note b)	10 U.L.
6, 10 (Note c)	9 U.L.

NOTES:
 a. 1 Unit Load (U.L.) = 40 μA HIGH/1.6 mA LOW
 b. 10 U.L. is the output LOW drive factor and 20 U.L. is the output HIGH drive factor.
 c. 9 U.L. is the output LOW drive factor and 19 U.L. is the output HIGH drive factor.

Fig. 3

FUNCTIONAL DESCRIPTION – The exclusive OR gate produces an output when the inputs are complementary. Two gates have an additional inverted output which provides directly a compare capability. The Boolean expressions for the gates are: $Z = \overline{A}B + A\overline{B}$; $\overline{Z} = AB + \overline{A}\overline{B}$.

TRUTH TABLE

A	B	Z	\overline{Z}
L	L	L	H
L	H	H	L
H	L	H	L
H	H	L	H

H = HIGH Voltage Level
L = LOW Voltage Level

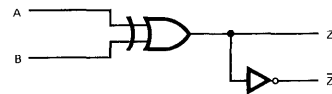

Fig. 4

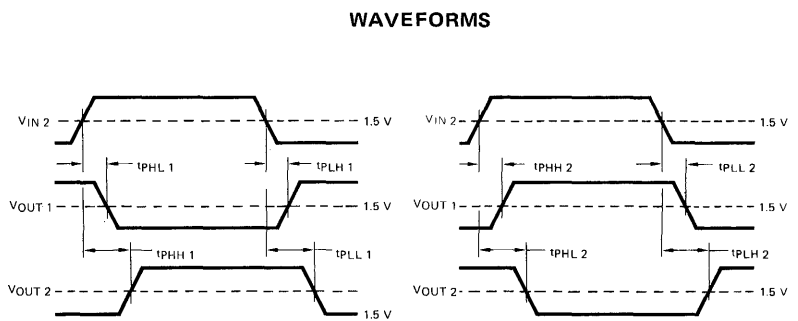
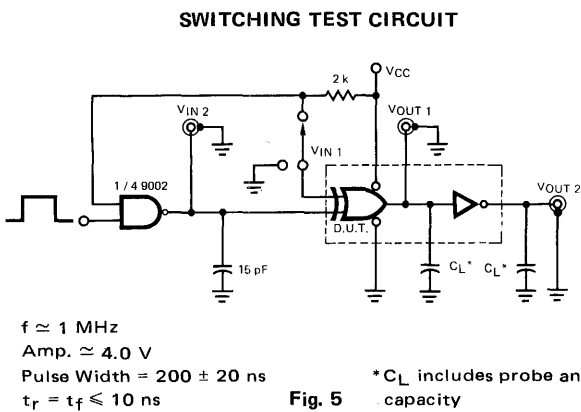

Fig. 6

Fig. 7

TTL/SSI • 9000 SERIES

ELECTRICAL CHARACTERISTICS 9014XC (T_A = 0°C to +75°C, V_{CC} = 5.0 V ±5%)

SYMBOL	PARAMETER	LIMITS				UNITS	TEST CONDITIONS			
		0°C		+25°C				+75°C		
		MIN.	MAX.	MIN.	TYP. MAX.			MIN.	MAX.	
V _{IH}	Input HIGH Voltage	1.9		1.8		1.6	Volts	Guaranteed Input HIGH Threshold Voltage for All Inputs		
V _{IL}	Input LOW Voltage		0.85		0.85		0.85	Volts	Guaranteed Input LOW Threshold Voltage for All Inputs	
V _{OH}	Output HIGH Voltage	2.4		2.4	3.1	2.4		Volts	V _{CC} = 4.75 V, I _{OH} = -1.20 mA I _{OH} = -1.14 mA (Pins 6 & 10) Inputs at V _{IL} & V _{IH} per Truth Table	
V _{OL}	Output LOW Voltage		0.45		0.29 0.45		0.45	Volts	V _{CC} = 5.25 V, I _{OL} = 16.0 mA I _{OL} = 14.4 mA (Pins 6 & 10) Inputs = 5.25 V or 0 V per Truth Table	
			0.45		0.45		0.45	Volts	V _{CC} = 4.75 V, I _{OL} = 14.1 mA I _{OL} = 12.7 mA (Pins 6 & 10) Inputs = 5.25 V or 0 V per Truth Table	
I _{IH}	Input HIGH Current				15 90		90	µA	V _{CC} = 5.25 V, V _{IN} = 4.5 V Other Inputs = GND	
I _{IL}	Input LOW Current		-2.4		-1.54 -2.4		-2.4	mA	V _{CC} = 5.25 V, V _{IN} = 0.45 V	
			-2.1		-2.1		-2.1	mA	V _{CC} = 4.75 V, Other Inputs = 5.25 V	
I _{CC}	V _{CC} Current, Gate On (each gate)		4.5		3.15 4.5		4.5	mA	V _{CC} = 5.0 V, One Input = 5.5 V, One Input = GND	
	V _{CC} Current, Gate Off (each gate)		8.7		6.06 8.7		8.7	mA	V _{CC} = 5.0 V, Inputs = GND	
	V _{CC} Current Per Inverter	On		6.1		3.6 6.1		6.1	mA	V _{CC} = 5.0 V, Input Node HIGH
		Off		1.7		1.07 1.7		1.7	mA	V _{CC} = 5.0 V, Input Node LOW
t _{PLH 1}	Switching Tests			3.0	8.0 13			ns	V _{CC} = 5.0 V, V _{IN1} = 5.0 V C _L = 15 pF See Figures 5 & 6 on previous page	
t _{PHL 1}				3.0	11 15			ns		
t _{PHH 1}				6.0	16 28			ns		
t _{PLL 1}				6.0	16 28			ns		
t _{PHH 2}				7.0	11 17			ns		
t _{PLL 2}	Switching Tests			7.0	15 19			ns	V _{CC} = 5.0 V, V _{IN1} = 0 V C _L = 15 pF See Figures 5 & 7 on previous page	
t _{PLH 2}				10	21 32			ns		
t _{PHL 2}				10	20 32			ns		
t _{PHL 2}				10	20 32			ns		

ELECTRICAL CHARACTERISTICS 9014XM (T_A = -55°C to +125°C, V_{CC} = 5.0 V ±10%)

SYMBOL	PARAMETER	LIMITS				UNITS	TEST CONDITIONS			
		-55°C		+25°C				125°C		
		MIN.	MAX.	MIN.	TYP. MAX.			MIN.	MAX.	
V _{IH}	Input HIGH Voltage	2.0		1.7		1.4	Volts	Guaranteed Input HIGH Threshold Voltage for All Inputs		
V _{IL}	Input LOW Voltage		0.8		0.9		0.8	Volts	Guaranteed Input LOW Threshold Voltage for All Inputs	
V _{OH}	Output HIGH Voltage	2.4		2.4	2.9	2.4		Volts	V _{CC} = 4.5 V, I _{OH} = -1.32 mA I _{OH} = -1.20 mA (Pins 6 & 10) Inputs at V _{IL} & V _{IH} per Truth Table	
V _{OL}	Output LOW Voltage		0.4		0.27 0.4		0.4	Volts	V _{CC} = 5.5 V, I _{OL} = 17.6 mA I _{OL} = 16 mA (Pins 6 & 10) Inputs = 5.5 V or 0 V per Truth Table	
			0.4		0.4		0.4	Volts	V _{CC} = 4.5 V, I _{OL} = 13.6 mA I _{OL} = 12.4 mA (Pins 6 & 10) Inputs = 5.5 V or 0 V per Truth Table	
I _{IH}	Input HIGH Current				10 90		90	µA	V _{CC} = 5.5 V, V _{IN} = 4.5 V Other Inputs = GND	
I _{IL}	Input LOW Current		-2.4		-1.65 -2.4		-2.4	mA	V _{CC} = 5.5 V, V _{IN} = 0.4 V	
			-1.86		-1.86		-1.86	mA	V _{CC} = 4.5 V, Other Inputs = 5.5 V	
I _{CC}	V _{CC} Current, Gate On (each gate)		4.2		3.15 4.2		4.2	mA	V _{CC} = 5.0 V, One Input = 5.5 V One Input = GND	
	V _{CC} Current, Gate Off (each gate)		8.1		6.06 8.1		8.1	mA	V _{CC} = 5.0 V, Inputs = GND	
	V _{CC} Current Per Inverter	On		5.5		3.5 5.5		5.5	mA	V _{CC} = 5.0 V, Input Node HIGH
		Off		1.6		1.07 1.6		1.6	mA	V _{CC} = 5.0 V, Input Node LOW
t _{PLH 1}	Switching Tests			3.0	7.0 10			ns	V _{CC} = 5.0 V, V _{IN1} = 5.0 V C _L = 15 pF See Figures 5 & 6 on previous page	
t _{PHL 1}				3.0	8.0 12			ns		
t _{PHH 1}				6.0	14 22			ns		
t _{PLL 1}				6.0	14 22			ns		
t _{PHH 2}				7.0	10 14			ns		
t _{PLL 2}	Switching Tests			7.0	12 16			ns	V _{CC} = 5.0 V, V _{IN1} = 0 V C _L = 15 pF See Figures 5 & 7 on previous page	
t _{PLH 2}				10	18 26			ns		
t _{PHL 2}				10	17 26			ns		
t _{PHL 2}				10	17 26			ns		

TTL/SSI • 9000 SERIES

QUAD NOR GATE – 9015

The TTL 9015 consists of three 2-input and one 4-input NOR gates. The NOR gate produces a LOW output if any of the inputs are HIGH.

LOGIC DIAGRAM

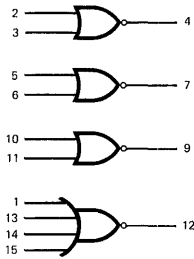

V_{CC} = Pin 16
GND = Pin 8

Fig. 1

CIRCUIT DIAGRAM

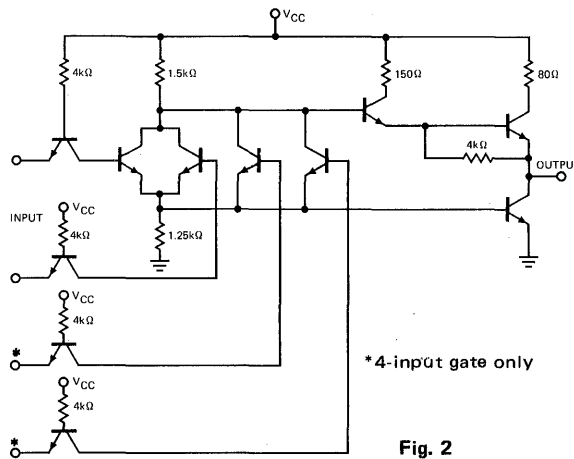

Fig. 2

LOADING FACTORS

PIN NAMES	LOADING
All Inputs	1 U.L.
All Outputs	10 U.L.

(1 U.L. = 40 μA HIGH/1.6 mA LOW)

Fig. 3

SWITCHING WAVEFORMS

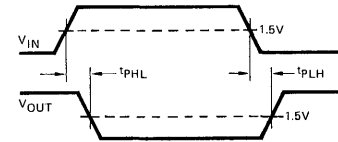

Fig. 4

ELECTRICAL CHARACTERISTICS 9015XC (0°C to +75°C, V_{CC} = 5.0 V ±5%)

SYMBOL	PARAMETER	LIMITS			UNITS	TEST CONDITIONS	
		0°C MIN. MAX.	+25°C MIN. TYP. MAX.	+75°C MIN. MAX.			
V _{IH}	Input HIGH Voltage	1.9	1.8	1.6	Volts	Guaranteed Input HIGH Threshold Voltage for All Inputs	
V _{IL}	Input LOW Voltage	0.85	0.85	0.85	Volts	Guaranteed Input LOW Threshold Voltage for All Inputs	
V _{OH}	Output HIGH Voltage	2.4	2.4 2.9	2.4	Volts	V _{CC} = 4.75 V, I _{OH} = -1.2 mA, Inputs = V _{IL}	
V _{OL}	Output LOW Voltage	0.45	0.21 0.45	0.45	Volts	V _{CC} = 5.25 V, I _{OL} = 16.0 mA, Inputs = 5.25 V	
		0.45	0.21 0.45	0.45	Volts	V _{CC} = 4.75 V, I _{OL} = 14.1 mA, Inputs = V _{IH}	
I _{IH}	Input HIGH Current		10 60	60	μA	V _{CC} = 5.25 V, GND on Other Inputs	
I _{IL}	Input LOW Current	-1.6	-1.0 -1.6	-1.6	mA	V _{CC} = 5.25 V V _{IN} = 0.45 V	
		-1.41	-0.91 -1.41	-1.41		V _{CC} = 4.75 V 5.25 V on Other Inputs	
I _{CC}	V _{CC} Current, Gate On (each gate)	6.55	4.25 6.55	6.55	mA	V _{CC} = 5.0 V	
	V _{CC} Current, Gate Off (each gate)	3.38	2.2 3.38	3.38			
		6.77	4.4 6.77	6.77			Inputs HIGH
							Inputs HIGH (4-Input Gate Only)
					Inputs LOW		
					Inputs LOW (4-Input Gate Only)		
t _{PLH}	Turn Off Delay		3.0 7.0 13		ns	V _{CC} = 5.0 V, C _L = 15 pF	
t _{PHL}	Turn On Delay		3.0 9.0 15		ns	(See Figure 4)	

ELECTRICAL CHARACTERISTICS 9015XM (-55°C to +125°C, V_{CC} = 5.0 V ±10%)

SYMBOL	PARAMETER	LIMITS			UNITS	TEST CONDITIONS	
		-55°C MIN. MAX.	+25°C MIN. TYP. MAX.	+125°C MIN. MAX.			
V _{IH}	Input HIGH Voltage	2.0	1.7	1.4	Volts	Guaranteed Input HIGH Threshold Voltage for All Inputs	
V _{IL}	Input LOW Voltage	0.8	0.9	0.8	Volts	Guaranteed Input LOW Threshold Voltage for All Inputs	
V _{OH}	Output HIGH Voltage	2.4	2.4 2.7	2.4	Volts	V _{CC} = 4.5 V, I _{OH} = -1.32 mA, Inputs = V _{IL}	
V _{OL}	Output LOW Voltage	0.4	0.21 0.4	0.4	Volts	V _{CC} = 5.5 V, Inputs = 5.5 V, I _{OL} = 17.6 mA	
		0.4	0.21 0.4	0.4	Volts	V _{CC} = 4.5 V, V _{IN} = V _{IH} , I _{OL} = 13.6 mA	
I _{IH}	Input HIGH Current		10 60	60	μA	V _{CC} = 5.5 V, V _{IN} = 4.5 V GND on Other Inputs	
I _{IL}	Input LOW Current	-1.6	-1.1 -1.6	-1.6	mA	V _{CC} = 5.5 V V _{IN} = 0.4 V	
		-1.24	-0.87 -1.24	-1.24		V _{CC} = 4.5 V 5.5 V on Other Inputs	
I _{CC}	V _{CC} Current, Gate On (each gate)	6.07	4.25 6.07	6.07	mA	V _{CC} = 5.0 V	
	V _{CC} Current, Gate Off (each gate)	3.2	2.2 3.2	3.2			
		6.4	4.4 6.4	6.4			Inputs HIGH
							Inputs HIGH (4-Input Gate Only)
					Inputs LOW		
					Inputs LOW (4-Input Gate Only)		
t _{PLH}	Turn Off Delay		3.0 6.0 10		ns	V _{CC} = 5.0 V, C _L = 15 pF	
t _{PHL}	Turn On Delay		3.0 8.0 12		ns	(See Figure 4)	

JK FLIP-FLOPS – 9000, 9001
DUAL JK FLIP-FLOPS – 9020, 9022

DESCRIPTION – The TTL 9000 series has four flip-flops to satisfy the storage requirements of a logic system. All are master/slave JK designs and have the same high speed and high noise immunity as the rest of the 9000 series. As with the gates, all inputs have diode clamps to reduce ringing caused by long lines and impedance mismatches.

The JK type flip-flop was chosen for all flip-flop elements in this family because of its inherent logic power. The input function required to produce a given sequence of states for a JK flip-flop will, in general, contain more "don't care" conditions than the corresponding function for an RS flip-flop. These additional "don't care" conditions will, in most cases, reduce the amount of gating elements required to implement the input function.

The master/slave design offers the advantage of a dc threshold on the clock input initiating the transition of the outputs, so that careful control of clock pulse rise and fall times is not required.

Data is accepted by the master while the clock is in the LOW state. Refer to the truth table for definition of HIGH and LOW data. Transfer from the master to the slave occurs on the LOW to HIGH transition of the clock. When the clock is HIGH, the J and K inputs are inhibited.

A joint (JK) input is provided for all flip-flops in this family. This common input removes the necessity of gating the clock signal with an external gate in many applications. This not only reduces package count, but also reduces the possibility of clock skew problems, since with internal gating provided, all flip-flops may be driven from a common clock line. Several TTL drivers may be used in parallel to drive this common clock line if the load exceeds the F.O. capability of the 9009 buffer.

The asynchronous inputs provide ability to control the state of the flip-flop independent of static conditions of the clock and synchronous inputs. Both asynchronous set and clear are provided on all flip-flops except the 9020, which because of a logic trade-off has only clear inputs. The set or clear pin being LOW absolutely guarantees that one output will be HIGH, but if opposing data is present at the synchronous inputs and the flip-flop is clocked, the LOW output may momentarily spike HIGH synchronous with a positive transition of the clock. If the LOW output of the flip-flop is connected to other flip-flop inputs clocked from the same line, the spike will be masked by the clock. If the clock is suspended during the time when the asynchronous inputs are activated, no spike will occur. When the spikes can cause problems, a simple solution is to common the joint JK inputs with the synchronous set or reset signal.

LOGIC DIAGRAMS

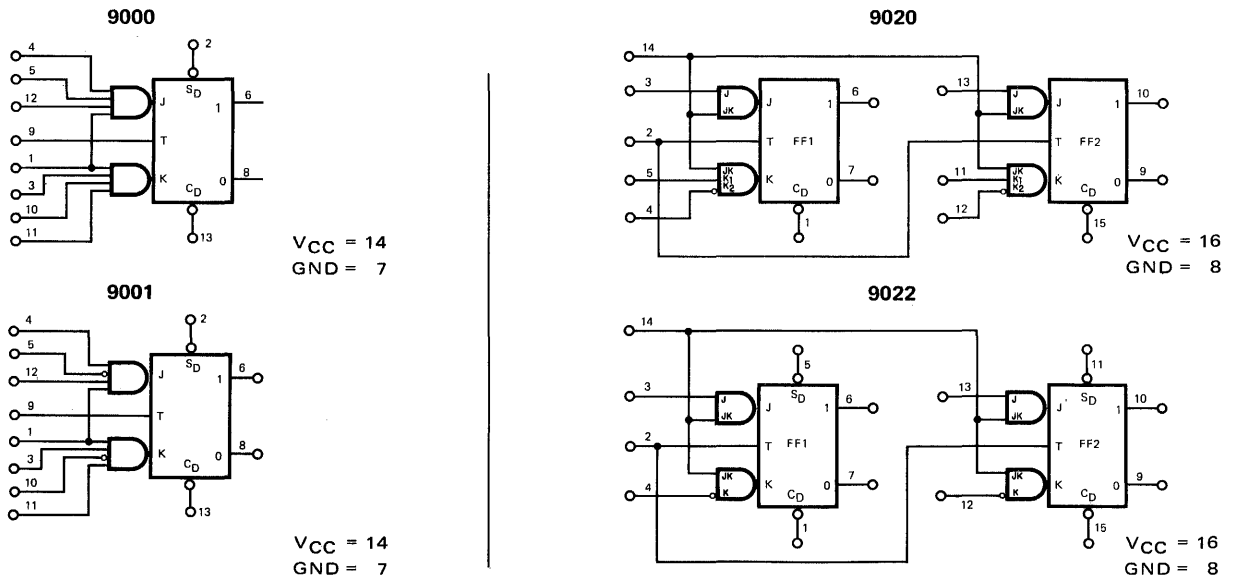

Fig. 1

FUNCTIONAL LOGIC DIAGRAMS

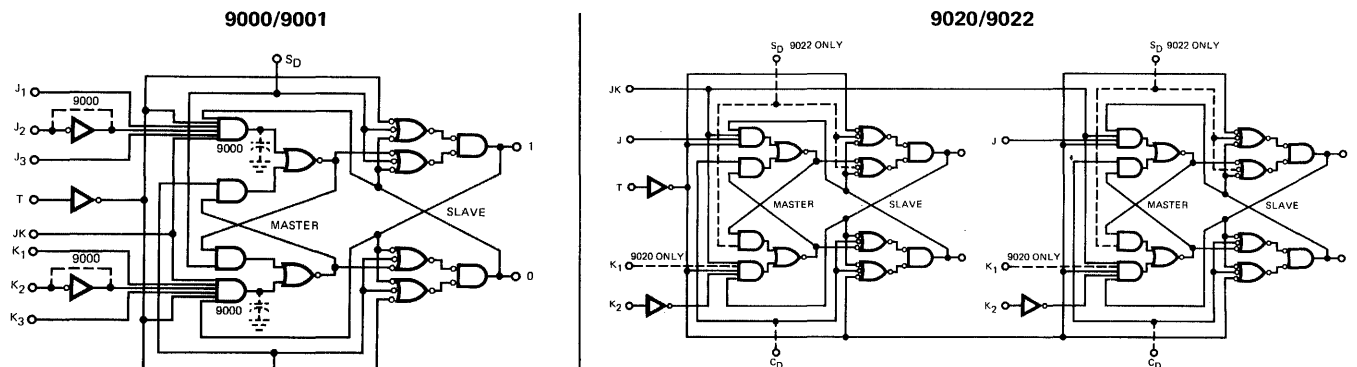

Fig. 2

TTL/SSI • 9000 SERIES

TRUTH TABLES

SYNCHRONOUS OPERATION

BEFORE CLOCK				AFTER CLOCK	
OUTPUTS		INPUTS		OUTPUTS	
ONE	ZERO	J	K	ONE	ZERO
L	H	L*	X	L	H
L	H	H*	X	H	L
H	L	X	L*	H	L
H	L	X	H*	L	H

ASYNCHRONOUS OPERATION

INPUTS		OUTPUTS	
S _D	C _D	ONE	ZERO
L	L	H	H
L	H	H	L
H	L	L	H
H	H	SYNCHRONOUS INPUTS CONTROL	

SYNCHRONOUS OPERATION – The truth table defines the next state of the flip-flop after a LOW to HIGH transition of the clock pulse. The next state is a function of the present state and the J and K inputs as shown in the table.

The J and K inputs in the table refer to the basic flip-flop J and K inputs as indicated on the logic diagrams. These internal inputs are for every flip-flop the result of a logic operation on the external J and K inputs. This operation is represented symbolically by AND gates in the logic diagram for each flip-flop. Logic diagrams are in accordance with MIL Standard 806B.

The L* symbol in the J and K input column is defined as meaning that **input does not go HIGH at any time while the clock is LOW.**

The H* symbol in the J or K input column is defined as meaning that the **input is HIGH at some time while the clock is LOW.**

The X symbol indicates that the condition of that input has no effect on the next state of the flip-flop.

The H and L symbols refer to steady state HIGH and LOW voltage levels, respectively.

UNUSED INPUTS – The 9001, 9020 and 9022 all have active level LOW synchronous inputs. When not in use they must be grounded. All other unused inputs, including asynchronous, should be tied HIGH for maximum operating speed.

ELECTRICAL CHARACTERISTICS 9000XC, 9001XC, 9020XC AND 9022XC (T_A = 0°C to 75°C, V_{CC} = 5.0 V ±5%)

SYMBOL	PARAMETER	LIMITS				UNITS	TEST CONDITIONS			
		0°C		25°C				75°C		
		MIN.	MAX.	MIN.	TYP.	MAX.	MIN.	MAX.		
V _{IH}	Input HIGH Voltage	1.9		1.8			1.6		Volts	Guaranteed Input HIGH Threshold Voltage for All Inputs
V _{IL}	Input LOW Voltage		0.85			0.85		0.85	Volts	Guaranteed Input LOW Threshold Voltage for All Inputs
V _{OH}	Output HIGH Voltage	2.4		2.4	3.0		2.4		Volts	V _{CC} = 4.75 V, I _{OH} = -1.2 mA
V _{OL}	Output LOW Voltage		0.45		0.21	0.45		0.45	Volts	V _{CC} = 4.75 V, I _{OL} = 14.1 mA V _{CC} = 5.25 V, I _{OL} = 16 mA
I _{IH}	Input HIGH Current All J, K Inputs T Inputs 9000, 9001				5.0	60		60	μA	V _{CC} = 5.25 V, V _{IN} = 4.5 V GND on Other Inputs
	JK Inputs 9000, 9001				10	120		120		
	T Inputs 9020, 9022				20	240		240		
	JK Inputs 9020, 9022				14	160		160		
I _{IL}	Input LOW Current All J, K Inputs T Inputs 9000, 9001		-1.60		-1.0	-1.60		-1.60	mA	V _{CC} = 5.25 V
	JK Inputs 9000, 9001		-3.20		-2.0	-3.20		-3.20		
	T Inputs 9020, 9022		-6.40		-4.0	-6.40		-6.40		
	JK Inputs 9020, 9022		-4.32		-2.7	-4.32		-4.32		
	S _D , C _D (all Flip-Flops)		-4.32		-2.7	-4.32		-4.32		
	Input LOW Current All J, K Inputs T Inputs 9000, 9001		-1.41		-0.94	-1.41		-1.41	mA	V _{CC} = 4.75 V
	JK Inputs 9000, 9001		-2.82		-1.88	-2.82		-2.82		
	T Inputs 9020, 9022		-5.64		-3.76	-5.64		-5.64		
	JK Inputs 9020, 9022		-3.78		-2.54	-3.78		-3.78		
	S _D , C _D (all Flip-Flops)		-3.78		-2.54	-3.78		-3.78		
I _{CC}	V _{CC} Current 9000		28		28		28	mA	V _{CC} = 5.0 V	
	9001		33		33		33			
	9020, 9022 each Flip-Flop		30		30		30			

TTL/SSI • 9000 SERIES

LOADING FACTORS

9000		9001	
PIN NAMES	LOADING (Note a)	PIN NAMES	LOADING (Note a)
JK	2 U.L.	JK	2 U.L.
J ₁ , J ₂ , J ₃ , K ₁ , K ₂ , K ₃ , T	1 U.L.	J ₁ , J ₂ , J ₃ , K ₁ , K ₂ , K ₃ , T	1 U.L.
S _D , C _D	3 U.L.	S _D , C _D	3 U.L.
Outputs (Note b)	10 U.L.	Outputs (Note b)	10 U.L.

9020		9022	
PIN NAMES	LOADING (Note a)	PIN NAMES	LOADING (Note a)
JK	4 U.L.	JK	4 U.L.
J, K ₁ , K ₂	1 U.L.	J, K	1 U.L.
T	2 U.L.	T	2 U.L.
C _D	3 U.L.	C _D	3 U.L.
Outputs (Note b)	10 U.L.	Outputs (Note b)	10 U.L.

NOTES:

- a. 1 Unit Load (U.L.) = 40 μ A HIGH/1.6 mA LOW; the HIGH load factor of 40 μ A measured at 2.4 V is considered equivalent to 60 μ A measured at 4.5 V for purposes of system loading calculations.
- b. 10 U.L. is the LOW drive factor and 30 U.L. is the HIGH drive factor.

Fig. 3

ELECTRICAL CHARACTERISTICS 9000XM, 9001XM, 9020XM AND 9022XM (T_A = -55°C to 125°C, V_{CC} = 5.0 V \pm 10%)

SYMBOL	PARAMETER	LIMITS						UNITS	TEST CONDITIONS	
		-55°C		25°C		125°C				
		MIN.	MAX.	MIN.	TYP.	MAX.	MIN.	MAX.		
V _{IH}	Input HIGH Voltage	2.0		1.7			1.4		Volts	Guaranteed Input HIGH Threshold Voltage for All Inputs
V _{IL}	Input LOW Voltage		0.8			0.9		0.8	Volts	Guaranteed Input LOW Threshold Voltage for All Inputs
V _{OH}	Output HIGH Voltage	2.4		2.4	2.7		2.4		Volts	V _{CC} = 4.5 V, I _{OH} = -1.2 mA
V _{OL}	Output LOW Voltage		0.4		0.21	0.4		0.4	Volts	V _{CC} = 4.5 V, I _{OL} = 12.4 mA V _{CC} = 5.5 V, I _{OL} = 16.0 mA
I _{IH}	Input HIGH Current								μ A	V _{CC} = 5.5 V, V _{IN} = 4.5 V GND on Other Inputs
	All J, K Inputs			5.0	60		60			
	T Inputs 9000, 9001									
	JK Inputs 9000, 9001			10	120		120			
	T Inputs 9020, 9022									
I _{IL}	Input LOW Current								mA	V _{CC} = 5.5 V
	All J, K Inputs	-1.60		-1.1	-1.60		-1.60			
	T Inputs 9000, 9001									
	JK Inputs 9000, 9001	-3.20		-2.2	-3.20		-3.20			
	T Inputs 9020, 9022									
	JK Inputs 9020, 9022	-6.40		-4.4	-6.40		-6.40			
	S _D , C _D (all Flip-Flops)	-4.32		-2.97	-4.32		-4.32			
Input LOW Current								mA	V _{CC} = 4.5 V	
All J, K Inputs	-1.24		-0.87	-1.24		-1.24				
T Inputs 9000, 9001										
JK Inputs 9000, 9001	-2.48		-1.74	-2.48		-2.48				
T Inputs 9020, 9022										
JK Inputs 9020, 9022	-4.96		-3.48	-4.96		-4.96				
S _D , C _D (all Flip-Flops)	-3.35		-2.35	-3.75		-3.35				
I _{CC}	V _{CC} Current								mA	V _{CC} = 5.0 V
	9000	24		13	24		24			
	9001	28		14	28		28			
	9020, 9022 each Flip-Flop	27		14	27		27			

TYPICAL INPUT AND OUTPUT CHARACTERISTICS
9000, 9001, 9020 AND 9022

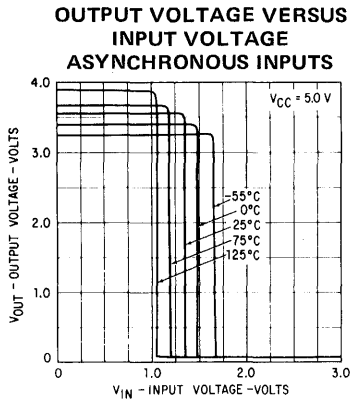

Fig. 4

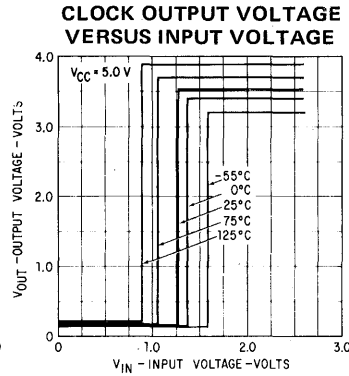

Fig. 5

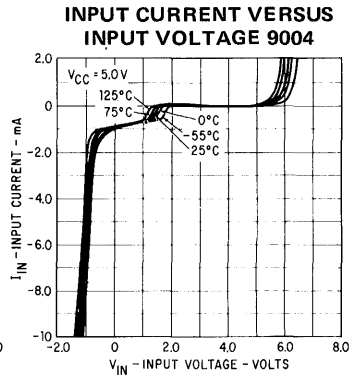

Fig. 6

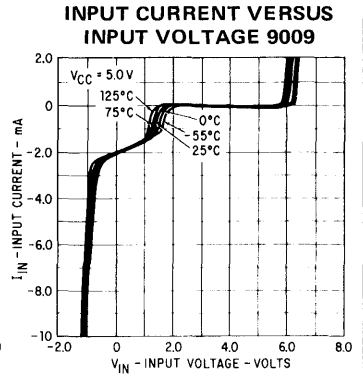

Fig. 7

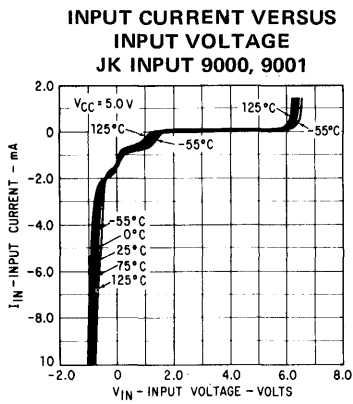

Fig. 8

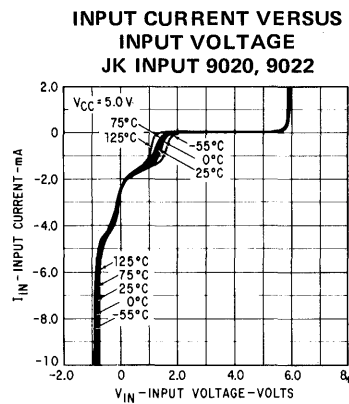

Fig. 9

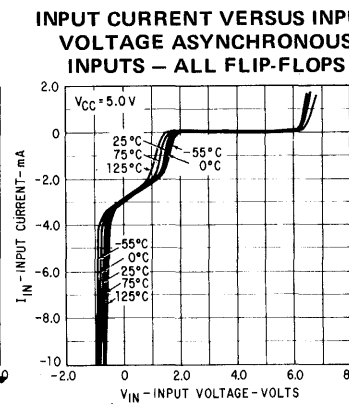

Fig. 10

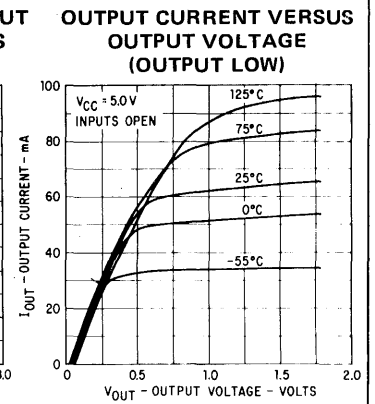

Fig. 11

SWITCHING CHARACTERISTICS ($T_A = 25^\circ\text{C}$, $V_{CC} = 5.0\text{V}$, $C_L = C_1 = 15\text{pF}$ of all flip-flops unless otherwise noted)

SYMBOL	PARAMETER		LIMITS			UNITS	FIGURES
			MIN.	TYP.	MAX.		
t_{PLH}	Clock to Output			12	20	ns	17, 18, 19
	S_D or C_D to Output			12	20		
t_{PHL}	Clock to Output			20	30	ns	17, 18, 19
	S_D or C_D to Output			25	35		
t_{set-up}	J, K or JK	9000XM	30	22		ns	17, 19
		9000XC	35	22			
		9001XM, 9020XM, 9022XM	10	8			
		9001XC, 9020XC, 9022XC	15	8			
	J or K Data Entry		17	12			
$t_{release}$	J, K or JK	9000 only		18	10	ns	17, 19
		9001, 9020, 9022		7	1.0		
	J or K Data Entry		11	4.0			
Pulse Widths	Clock	9000 only	Positive		20	ns	17, 19
			Negative		25		
		9001, 9020, 9022	Positive		8.0	ns	17, 18, 19
			Negative		10		
Toggle Frequency	S_D or C_D	9000 only	Negative		25	ns	17, 18, 19
			9001, 9020, 9022		20		
						50	MHz

MAX. AND MIN. PROPAGATION DELAYS VERSUS AMBIENT TEMPERATURE T TO OUTPUT

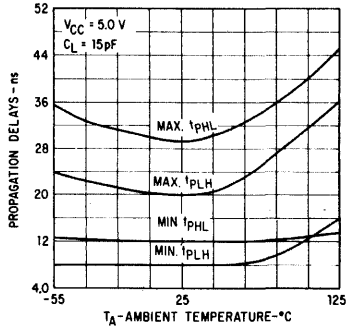

Fig. 12

MAX. AND MIN. PROPAGATION DELAYS VERSUS AMBIENT TEMPERATURE ASYNCHRONOUS INPUTS TO OUTPUTS

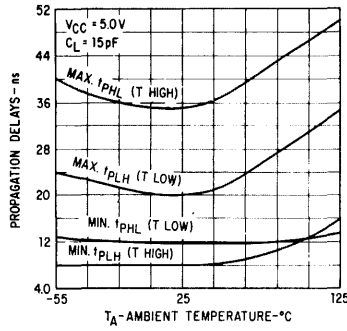

Fig. 13

INCREASE IN ASYNCHRONOUS OR CLOCK INPUT DUE TO OUTPUT CAPACITANCE

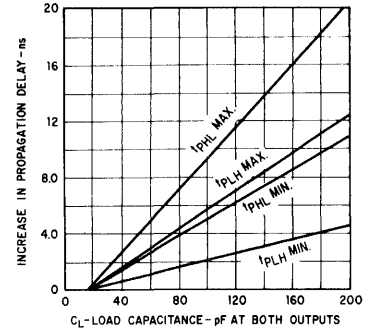

Fig. 14

9001 - 9020 - 9022 SET-UP/RELEASE TIME AND NEGATIVE CLOCK PULSE WIDTH VERSUS AMBIENT TEMPERATURE

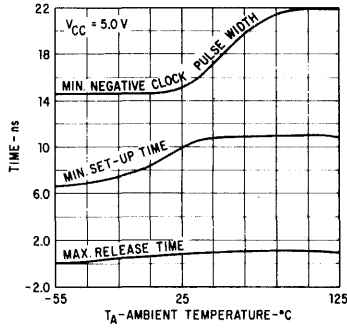

Fig. 15

9000 NEGATIVE CLOCK PULSE WIDTH SET-UP/RELEASE TIME VERSUS AMBIENT TEMPERATURE

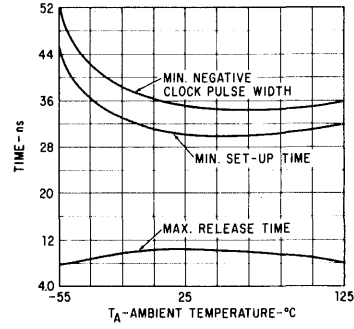

Fig. 16

SWITCHING TEST CIRCUITS

9000/9001

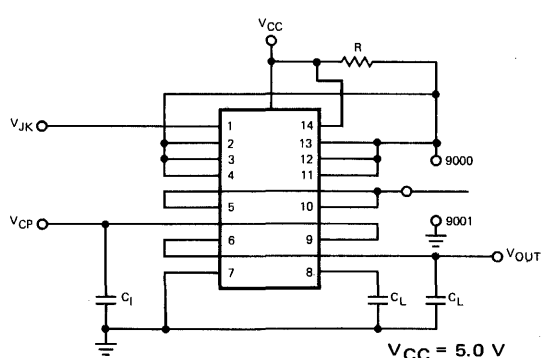

Fig. 17

9020/9022

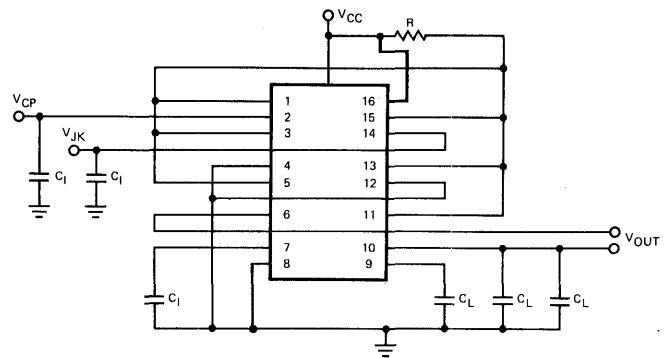

Fig. 18

$V_{CC} = 5.0 V$
 $R = 2.0 k\Omega$

$C_1 = C_L = 15 pF$ including probe and jig capacitance

WAVEFORMS

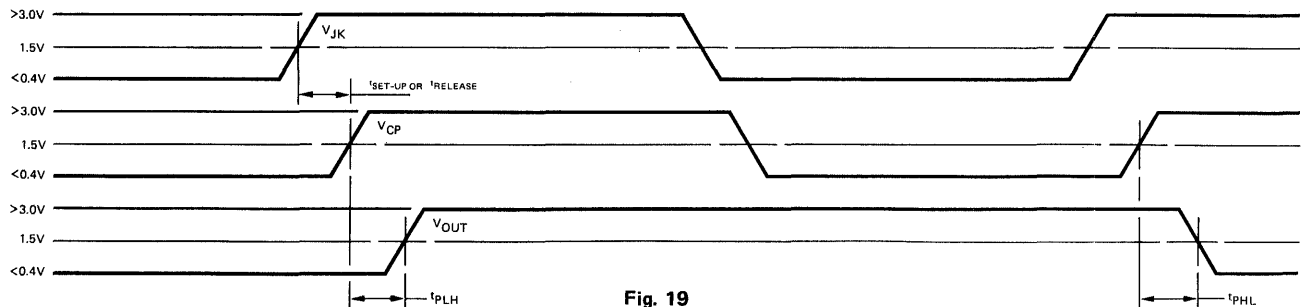

Fig. 19

SWITCHING TEST NOTES

t_{PLH} and t_{PHL}

1. V_{JK} should be kept at the HIGH logic level when performing t_{PLH}/t_{PHL} tests.
2. Drive the clock pulse input with a suitable pulse source. t_{PLH} and t_{PHL} delays are as defined in the waveforms.

t_{set-up}

1. t_{set-up} is defined as the minimum time required for a HIGH to be present at a synchronous logic input at any time during the LOW state of the clock in order for the flip-flop to respond to the data.
2. The test for t_{set-up} is performed by adjusting the timing relationship between the V_{CP} and V_{JK} inputs to the t_{set-up} minimum value. A device that passes the test will have the output waveform shown. The output of a device that does not pass the t_{set-up} test will remain at a static logic level (no switching will occur).

t_{release}

1. t_{release} is defined as the maximum time allowed for a HIGH to be present at a synchronous logic input at any time during the LOW state of the clock and not be recognized.
2. The test for t_{release} is performed by adjusting the timing relationship between V_{CP} and V_{JK} to the t_{release} maximum value. The outputs of devices that pass will remain at static logic levels. In order to check both J and K sides of the flip-flop it is necessary to perform the test with the flip-flop in each of its two possible states, i.e., set and clear. This can be accomplished by making use of the appropriate direct inputs to establish the state before a test. The outputs of devices that do not pass the t_{release} test will exhibit pulses instead of static levels.

RECOMMENDED INPUT PULSE SOURCES

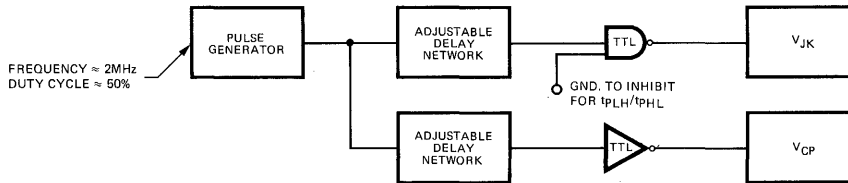

DTL9932 gates with adjustable capacitors connected from extender inputs to ground make suitable delay elements.

9000 SCHEMATIC DIAGRAM

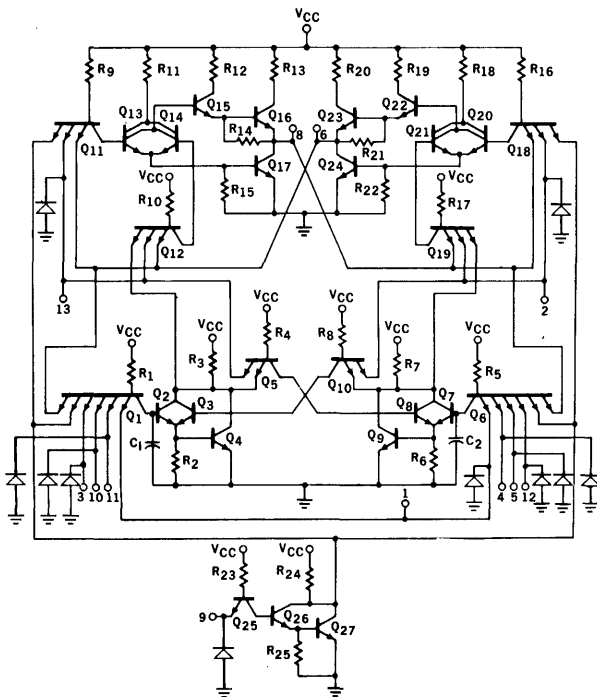

9001 SCHEMATIC DIAGRAM

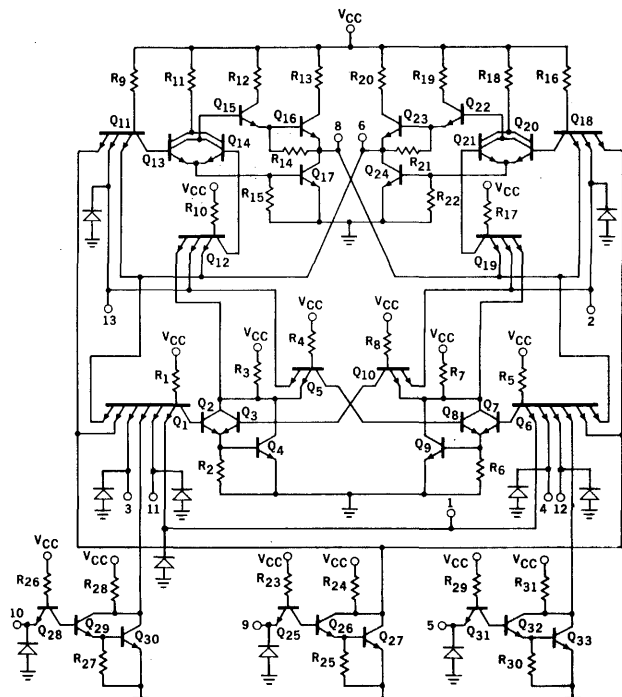

VCC = Pin 14
GND = Pin 7

9020 SCHEMATIC DIAGRAM

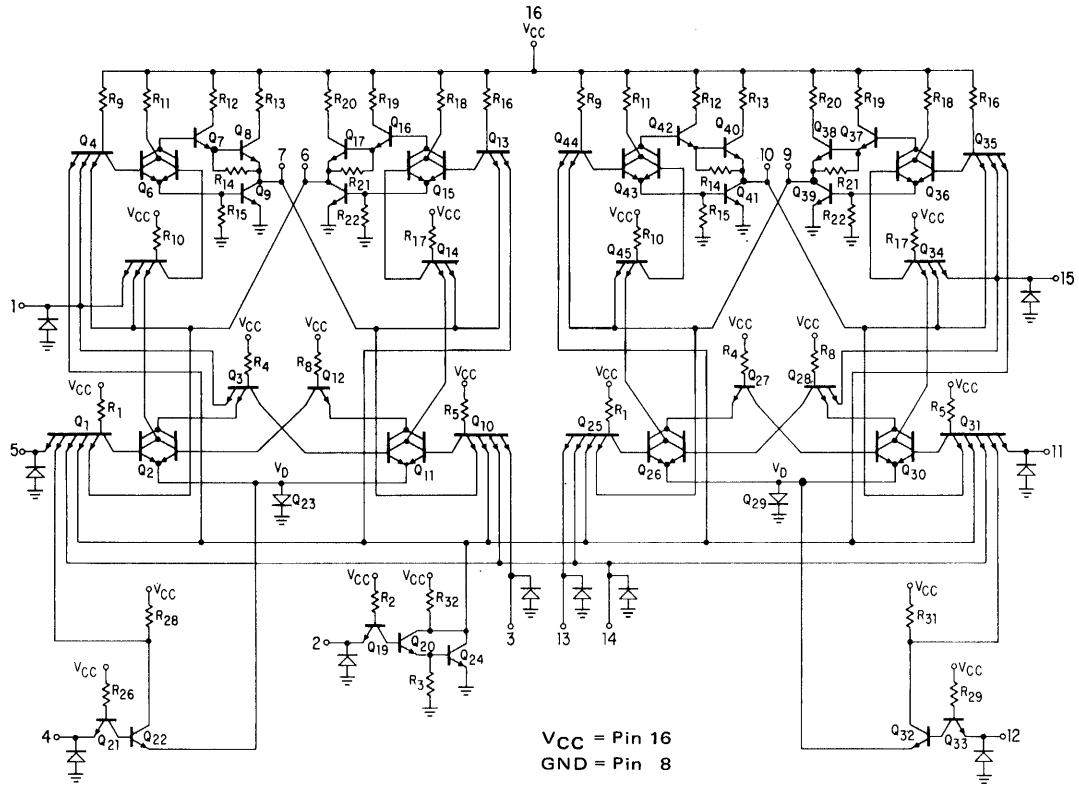

NOMINAL COMPONENT VALUES (ALL FLIP-FLOPS)

- R1, R4, R5, R8, R10, R14, R17, R21, R22, R23, R24, R26, R29 = 4.0 kΩ
- R2, R3, R6, R7 = 2.0 kΩ
- R9, R16, R28, R31 = 6.0 kΩ
- R11, R18 = 1.5 kΩ
- R12, R19 = 150 Ω
- R13, R20 = 80 Ω
- R15, R22, R25, R27, R30 = 1.25 kΩ
- R32 = 1.0 kΩ
- C1, C2 = 10 pF

9022 SCHEMATIC DIAGRAM

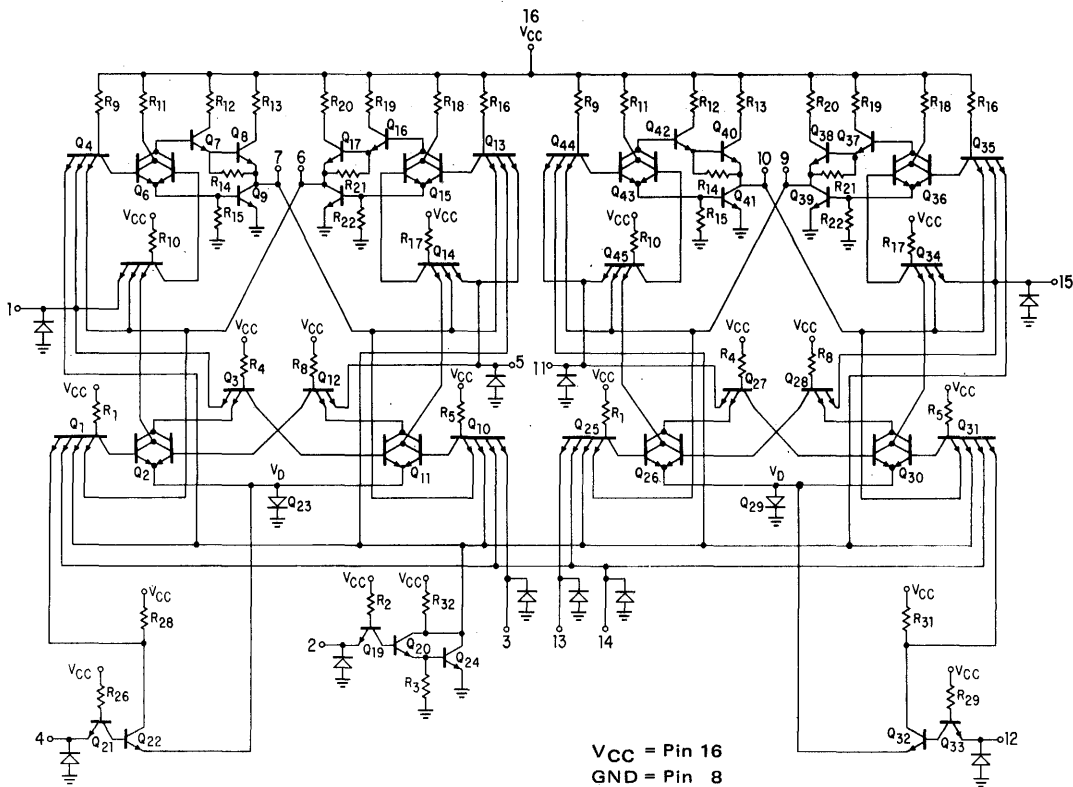

APPLICATIONS

SYNCHRONOUS BDC COUNTER

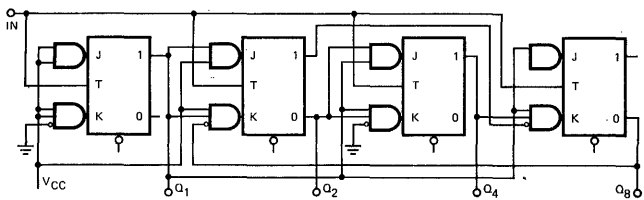

Two TTL 9020 Dual Flip-Flops require no additional gating to produce a fully synchronous 8421 code BCD Counter.

DIVIDE BY TEN COUNTER

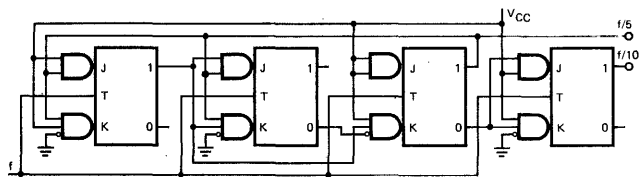

Two TTL 9020 Dual Flip-Flops require no additional gating elements to produce divide by ten circuit with a square wave divide by ten output and a divide by five output.

BINARY COUNTER WITH ASYNCHRONOUS PARALLEL LOAD AND CLEAR

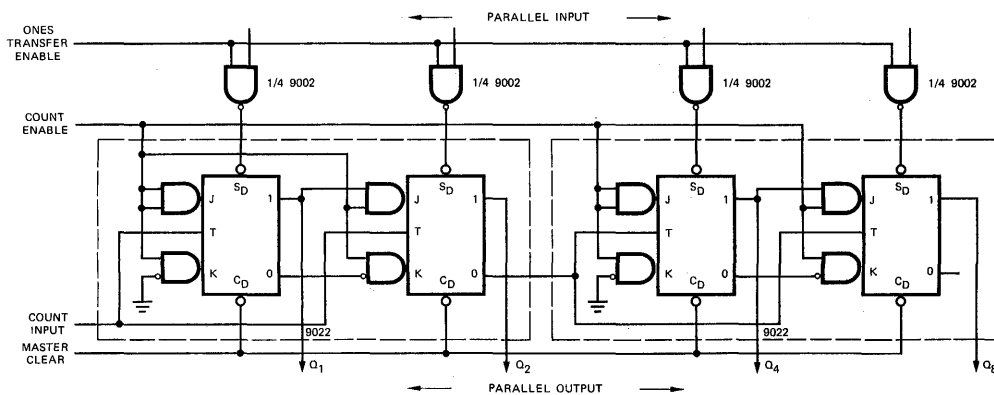

Binary counter using synchronous 2-bit stages with trickle down between stages illustrates method of utilizing dual JK flip-flops having common clocks in counter applications.

DUAL JK̄ (OR D) FLIP-FLOP — 9024

The 9024 consists of two high speed, completely independent transition clocked JK̄ flip-flops. The clocking operation is independent of rise and fall times of the clock waveform. The JK̄ design allows operation as a D flip-flop by simply connecting the J and K pins together.

LOGIC DIAGRAM

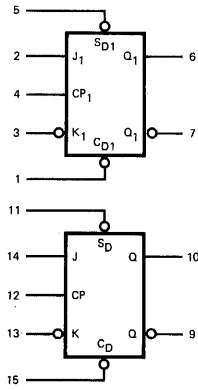

Fig. 1

FUNCTIONAL LOGIC DIAGRAM

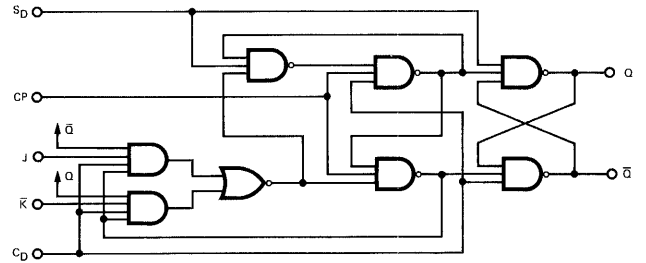

Fig. 2

LOADING FACTORS

PIN NAMES	LOADING
	(Note a)
J, K̄	1 U.L.
Clock, S _D	2 U.L.
C _D	3 U.L.
Outputs (Note b)	10 U.L.

Fig. 3

NOTES:

- a. 1 Unit Load (U.L.) = 40 μA HIGH/1.6 mA LOW; the HIGH load factor of 40 μA measured at 2.4 V is considered equivalent to 60 μA measured at 4.5 V for purposes of system loading calculations.
- b. 10 U.L. is the LOW drive factor and 30 U.L. is the HIGH drive factor.

TRUTH TABLES

SYNCHRONOUS ENTRY J-K̄ MODE OPERATION

INPUTS AT t _n		OUTPUTS AT t _{n+1}	
J	K̄	Q	Q̄
L	H	No Change	
L	L	L	H
H	H	H	L
H	L	Toggles	

SYNCHRONOUS ENTRY D MODE OPERATION

INPUTS AT t _n	OUTPUTS AT t _{n+1}	
D	Q	Q̄
L	L	H
H	H	L

ASYNCHRONOUS ENTRY INDEPENDENT OF CLOCK & SYNCHRONOUS INPUTS

INPUTS		OUTPUTS	
S _D	C _D	Q	Q̄
5(11)	1(15)	6(10)	7(9)
L	L	H	H
L	H	H	L
H	L	L	H
H	H	No Change	

L = LOW Logic Level
H = HIGH Logic Level

TTL/SSI • 9000 SERIES

ELECTRICAL CHARACTERISTICS 9024XC ($T_A = 0^\circ\text{C}$ to 75°C , $V_{CC} = 5\text{ V} \pm 5\%$) (Note 3)

SYMBOL	PARAMETER	LIMITS						UNITS	TEST CONDITIONS		
		0°C		25°C			75°C				
		MIN.	MAX.	MIN.	TYP.	MAX.	MIN.	MAX.			
V_{IH}	Input HIGH Voltage	1.9		1.8			1.6		Volts	Guaranteed Input HIGH Threshold Voltage for All Inputs	
V_{IL}	Input LOW Voltage		0.85			0.85		0.85	Volts	Guaranteed Input LOW Threshold Voltage for All Inputs	
V_{OH}	Output HIGH Voltage	2.4		2.4	3.0		2.4		Volts	$V_{CC} = 4.75\text{ V}$, $I_{OH} = -1.2\text{ mA}$	
V_{OL}	Output LOW Voltage		0.45		0.21	0.45		0.45	Volts	$V_{CC} = 4.75\text{ V}$, $I_{OL} = 14.1\text{ mA}$ $V_{CC} = 5.25\text{ V}$, $I_{OL} = 16\text{ mA}$	
I_{IH}	Input HIGH Current J, \bar{K}				5.0	60		60	μA	$V_{CC} = 5.25\text{ V}$, $V_{IN} = 4.5\text{ V}$ GND on Other Inputs	
	Clock Input, S_D				10	120		120			
	C_D				20	240		240			
I_{IL}	Input LOW Current J, \bar{K}		-1.6		-1.0	-1.6		-1.6	mA	$V_{CC} = 5.25\text{ V}$	$V_{IN} = 0.45\text{ V}$ 4.5 V on Other Inputs
	Clock Input, S_D		-3.2		-2.0	-3.2		-3.2			
	C_D (Note 4)		-4.8		-3.0	-4.8		-4.8			
	J, \bar{K}		-1.41		-0.94	-1.41		-1.41	mA	$V_{CC} = 4.75\text{ V}$	
	Clock Input, S_D		-2.82		-1.88	-2.82		-2.82			
	C_D (Note 4)		-4.23		-2.82	-4.23		-4.23			
I_{SC}	Output HIGH Short Circuit Current	-30	-100	-30	-65	-100	-30	-100	mA	$V_{CC} = 5.25\text{ V}$, $V_{OUT} = 0.0\text{ V}$	
I_{CC}	Current Drain				9.0	14			mA	Per Flip-Flop in Worst Logic State	

ELECTRICAL CHARACTERISTICS 9024XM ($T_A = -55^\circ\text{C}$ to 125°C , $V_{CC} = 5\text{ V} \pm 10\%$) (Note 3)

SYMBOL	PARAMETER	LIMITS						UNITS	TEST CONDITIONS		
		-55°C		25°C			125°C				
		MIN.	MAX.	MIN.	TYP.	MAX.	MIN.	MAX.			
V_{IH}	Input HIGH Voltage	2.0		1.7			1.4		Volts	Guaranteed Input HIGH Threshold Voltage for All Inputs	
V_{IL}	Input LOW Voltage		0.8			0.9		0.8	Volts	Guaranteed Input LOW Threshold Voltage for All Inputs	
V_{OH}	Output HIGH Voltage	2.4		2.4	2.7		2.4		Volts	$V_{CC} = 4.5\text{ V}$, $I_{OH} = -1.2\text{ mA}$	
V_{OL}	Output LOW Voltage		0.4		0.2	0.4		0.4	Volts	$V_{CC} = 4.5\text{ V}$, $I_{OL} = 12.4\text{ mA}$	
			0.4		0.25	0.4		0.4	Volts	$V_{CC} = 5.5\text{ V}$, $I_{OL} = 16\text{ mA}$	
I_{IH}	Input HIGH Current J, \bar{K}				5.0	60		60	μA	$V_{CC} = 5.5\text{ V}$, $V_{IN} = 4.5\text{ V}$ GND on Other Inputs	
	Clock Input, S_D				10	120		120			
	C_D				20	240		240			
I_{IL}	Input LOW Current J, \bar{K}		-1.6		-1.1	-1.6		-1.6	mA	$V_{CC} = 5.5\text{ V}$	$V_{IN} = 0.4\text{ V}$ 4.5 V on Other Inputs
	Clock Input, S_D		-3.2		-2.2	-3.2		-3.2			
	C_D (Note 4)		-4.8		-3.3	-4.8		-4.8			
	J, \bar{K}		-1.24		-0.91	-1.24		-1.24	mA	$V_{CC} = 4.5\text{ V}$	
	Clock Input, S_D		-2.48		-1.82	-2.48		-2.48			
	C_D (Note 4)		-3.72		-2.73	-3.72		-3.72			
I_{SC}	Output HIGH Short Circuit Current	-30	-100	-30	-65	-100	-30	-100	mA	$V_{CC} = 5.5\text{ V}$, $V_{OUT} = 0.0\text{ V}$	
I_{CC}	Current Drain				9.0	14			mA	Per Flip-Flop in Worst Logic State	

NOTES:

1. The maximum V_{CC} value of 8.0 V is not the primary factor in determining the maximum V_{CC} which may be applied to a number of interconnected devices. The voltage at a HIGH output is approximately 1 V_{BE} below the V_{CC} voltage, so the primary limit on the V_{CC} is that the voltage at any input may not go above 5.5 V unless the current is limited, so this effectively limits the system V_{CC} to approximately 7.0 V.
2. Because of the input clamp diodes, excess current can be drawn out of the inputs if the dc input voltage is more negative than -0.5 V. The diode is designed to clamp off large negative ac swings associated with fast fall times and long lines. This maximum rating is intended only to limit the steady state input voltage and current.
3. Positive current is into device and negative current is out of device.
4. Denotes maximum current under normal operation. These currents may increase up to 4 I_{IL} if J, \bar{K} = HIGH and S_D = LOW.

TTL/SSI • 9000 SERIES

SWITCHING CHARACTERISTICS ($T_A = 25^\circ\text{C}$)

SYMBOL	PARAMETER	LIMITS			UNITS	TEST CONDITIONS
		MIN.	25°C TYP.	MAX.		
t_{PLH}	Clock to Q or \bar{Q}		12	20	ns	$V_{CC} = 5.0\text{ V}$ $C_L = 15\text{ pF}$ Each Flip-Flop
t_{PHL}	Clock to Q or \bar{Q}		22	33	ns	
t_{release}			2.0		ns	
$t_{\text{set-up}}$		20	15	1.0	ns	
t_{PLH}	S_D to Q, C_D to \bar{Q}		8.0	12	ns	
t_{PHL}	S_D to \bar{Q} , C_D to Q		20	25	ns	
	Toggle Frequency	25	30		MHz	

SWITCHING TEST CIRCUIT

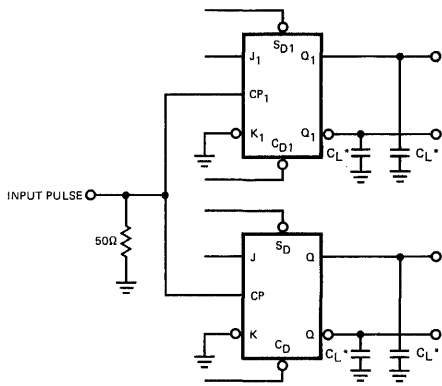

WAVEFORMS

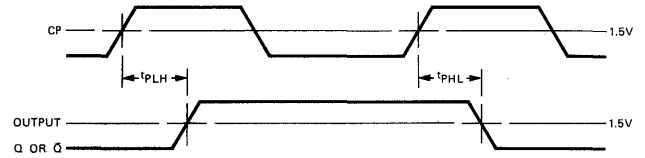

* C_L includes probe and jig capacitance

INPUT CURRENT VERSUS INPUT VOLTAGE

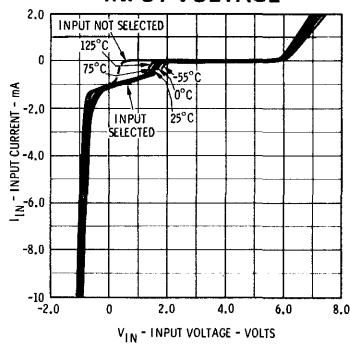

OUTPUT CURRENT VERSUS OUTPUT VOLTAGE (OUTPUT HIGH)

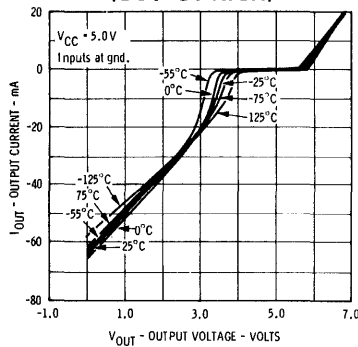

OUTPUT CURRENT VERSUS OUTPUT VOLTAGE (OUTPUT LOW)

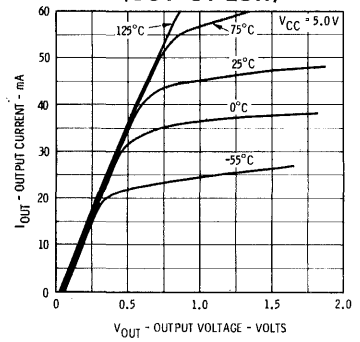

QUAD 2-INPUT NAND GATE

LOGIC AND CONNECTION DIAGRAM

DIP (TOP VIEW)

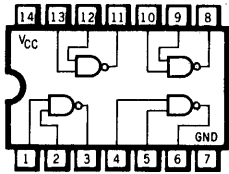

Positive logic: $Y = \overline{AB}$

FLATPAK (TOP VIEW)

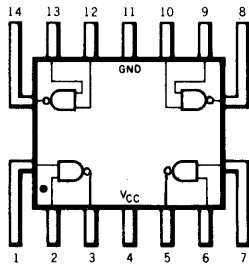

SCHEMATIC DIAGRAM (EACH GATE)

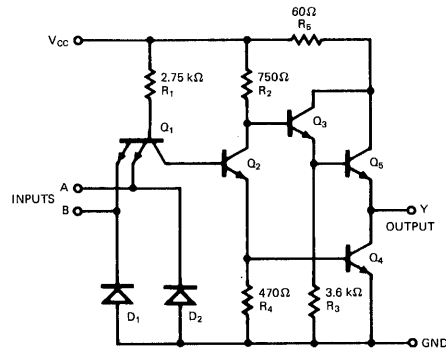

Component values shown are typical.

RECOMMENDED OPERATING CONDITIONS

PARAMETER	9H00XM/54H00XM			9H00XC/74H00XC			UNITS
	MIN.	TYP.	MAX.	MIN.	TYP.	MAX.	
Supply Voltage V_{CC}	4.5	5.0	5.5	4.75	5.0	5.25	Volts
Operating Free-Air Temperature Range	-55	25	125	0	25	70	°C
Input Loading for Each Input			1.25			1.25	U.L.

X = package type; F for Flatpak, D for Ceramic Dip, P for Plastic Dip. See Packaging Information Section for packages available on this product.

ELECTRICAL CHARACTERISTICS OVER OPERATING TEMPERATURE RANGE (Unless Otherwise Noted)

SYMBOL	PARAMETER	LIMITS			UNITS	TEST CONDITIONS (Note 1)	TEST FIGURE
		MIN.	TYP. (Note 2)	MAX.			
V_{IH}	Input HIGH Voltage	2.0			Volts	Guaranteed Input HIGH Voltage	1
V_{IL}	Input LOW Voltage			0.8	Volts	Guaranteed Input LOW Voltage	2
V_{OH}	Output HIGH Voltage	2.4			Volts	$V_{CC} = \text{MIN.}, I_{OH} = -0.5 \text{ mA}, V_{IN} = 0.8 \text{ V}$	2
V_{OL}	Output LOW Voltage			0.4	Volts	$V_{CC} = \text{MIN.}, I_{OL} = 20 \text{ mA}, V_{IN} = 2.0 \text{ V}$	1
I_{IH}	Input HIGH Current			50	μA	$V_{CC} = \text{MAX.}, V_{IN} = 2.4 \text{ V}$	Each Input 4
				1.0	mA	$V_{CC} = \text{MAX.}, V_{IN} = 5.5 \text{ V}$	
I_{IL}	Input LOW Current			-2.0	mA	$V_{CC} = \text{MAX.}, V_{IN} = 0.4 \text{ V}, \text{ Each Input}$	3
I_{OS}	Output Short Circuit Current (Note 3)	-40		-100	mA	$V_{CC} = \text{MAX.}$	5
I_{CCH}	Supply Current HIGH		10	16.8	mA	$V_{CC} = \text{MAX.}, V_{IN} = 0 \text{ V}$	6
I_{CCL}	Supply Current LOW		26	40	mA	$V_{CC} = \text{MAX.}, V_{IN} = 4.5 \text{ V}$	6

SWITCHING CHARACTERISTICS ($T_A = 25^\circ\text{C}$)

SYMBOL	PARAMETER	LIMITS			UNITS	TEST CONDITIONS	TEST FIGURE
		MIN.	TYP.	MAX.			
t_{PLH}	Turn Off Delay Input to Output		5.9	10	ns	$V_{CC} = 5.0 \text{ V}$ $C_L = 25 \text{ pF}$ $R_L = 280 \Omega$	T
t_{PHL}	Turn On Delay Input to Output		6.2	10	ns		

NOTES:

- For conditions shown as MIN. or MAX., use the appropriate value specified under recommended operating conditions for the applicable device type.
- Typical limits are at $V_{CC} = 5.0 \text{ V}, 25^\circ\text{C}$.
- Not more than one output should be shorted at a time, and duration of short-circuit test should not exceed 1 second.

LPTTL/SSI 9L00

LOW POWER QUAD 2-INPUT NAND GATE

DESCRIPTION — The low power TTL/SSI 9L00 consists of four NAND gates. Each gate has two inputs and performs positive logic. The 9L00 is designed for low power and medium speed operation.

- TYPICAL PROPAGATION DELAY OF 20 ns
- INPUT CLAMP DIODES LIMIT HIGH SPEED TERMINATION EFFECTS
- ALL CERAMIC "HERMETIC" 14-LEAD DUAL IN-LINE AND FLAT PACKAGES
- TTL COMPATIBLE

PIN NAMES

INPUTS (Pins 1, 2, 4, 5, 9, 10, 12, 13)
 OUTPUTS (Pins 3, 6, 8, 11)

LOADING	
HIGH	LOW
0.5 U.L.	0.25 U.L.
10 U.L.	2.5 U.L.

1 Unit Load (U.L.) = 40 μ A HIGH/1.6 mA LOW.

SCHEMATIC DIAGRAM

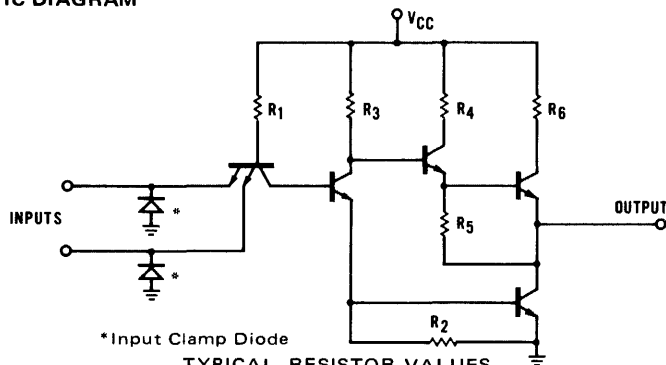

*Input Clamp Diode
TYPICAL RESISTOR VALUES
 $R_1 = 16\text{ k}\Omega$ $R_3 = 6\text{ k}\Omega$ $R_5 = 16\text{ k}\Omega$
 $R_2 = 5\text{ k}\Omega$ $R_4 = 600\ \Omega$ $R_6 = 320\ \Omega$

LOGIC SYMBOL

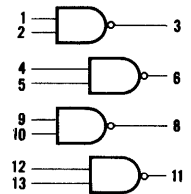

$V_{CC} = \text{PIN } 14$
 $\text{GND} = \text{PIN } 7$

**CONNECTION DIAGRAM
 DIP (TOP VIEW)**

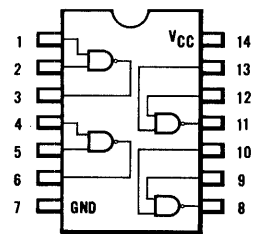

FLATPAK (TOP VIEW)

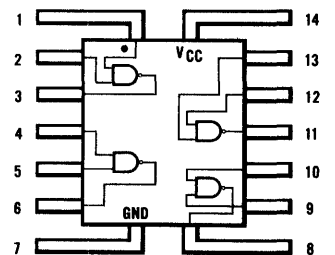

FAIRCHILD LPTTL/SSI • 9L00

ABSOLUTE MAXIMUM RATINGS (above which the useful life may be impaired)

Storage Temperature	-65°C to +150°C
Temperature (Ambient) Under Bias	-55°C to +125°C
V _{CC} Pin Potential to Ground Pin	-0.5 V to +7.0 V
*Input Voltage (dc)	-0.5 V to +5.5 V
*Input Current (dc)	-30 mA to +5.0 mA
Voltage Applied to Outputs (Output HIGH)	-0.5 V to +V _{CC} value
Output Current (dc) (Output LOW)	+30 mA

*Either Input Voltage limit or Input Current limit is sufficient to protect the inputs.

GUARANTEED OPERATING RANGES

PART NUMBER	SUPPLY VOLTAGE (V _{CC})			TEMPERATURE
	MIN.	TYP.	MAX.	
9L00XM	4.5 V	5.0 V	5.5 V	-55°C to 125°C
9L00XC	4.75 V	5.0 V	5.25 V	0°C to 75°C

X=package type; F for Flatpak, D for Ceramic Dip, P for Plastic Dip. See Packaging Information Section for packages available on this product.

ELECTRICAL CHARACTERISTICS OVER OPERATING TEMPERATURE RANGE (Unless Otherwise Noted) (See Notes 1, 2)

SYMBOL	PARAMETER	LIMITS			UNITS	CONDITIONS
		MIN.	TYP. Note 3	MAX.		
V _{OH}	Output HIGH Voltage	2.4	3.6		Volts	V _{CC} = MIN., I _{OH} = -0.4 mA, V _{IN} = V _{IL}
V _{OL}	Output LOW Voltage		0.1	0.3	Volts	V _{CC} = MIN., I _{OL} = 4.0 mA, V _{IN} = V _{IH}
V _{IH}	Input HIGH Voltage	2.0			Volts	Guaranteed input LOW threshold voltage for all inputs
V _{IL}	Input LOW Voltage			0.7	Volts	Guaranteed input HIGH threshold voltage for all inputs
I _{IL}	Input LOW Current		-0.25	-0.4	mA	V _{CC} = MAX., V _{IN} = 0.3 V, Other Input = 4.5V
I _{IH}	Input HIGH Current		2.0	20	μA	V _{CC} = MAX., V _{IN} = 2.4 V
				1.0	mA	V _{CC} = MAX., V _{IN} = 5.5 V
I _{SC} (Note 4)	Output Short Circuit Current	-10	-22	-40	mA	V _{CC} = MAX., V _{OUT} = 0.0 V, Inputs Grounded
I _{CC}	Power Supply Current per Gate		0.9	1.56	mA	V _{CC} = MAX., Inputs HIGH
			0.28	0.41	mA	V _{CC} = MAX., Inputs LOW

- NOTES: 1. Conditions for testing, not shown in the Table, are chosen to guarantee operation under "worst case" conditions.
 2. The specified LIMITS represent the "worst case" value for the parameter. Since these "worst case" values normally occur at the temperature and supply voltage extremes, additional noise immunity and guard banding can be achieved by decreasing the allowable system operating ranges.
 3. Typical limits are at V_{CC} = 5.0 V, 25°C, and max. loading.
 4. Not more than one output should be shorted at a time.

SWITCHING CHARACTERISTICS (T_A = 25°C)

SYMBOL	PARAMETER	LIMITS			UNITS	CONDITIONS
		MIN.	TYP.	MAX.		
t _{PLH}	Turn Off Delay Input to Output		15		ns	V _{CC} = 5.0V See Fig. 1 C _L = 15 pF
t _{PHL}	Turn On Delay Input to Output		25		ns	

SWITCHING TIME WAVEFORMS

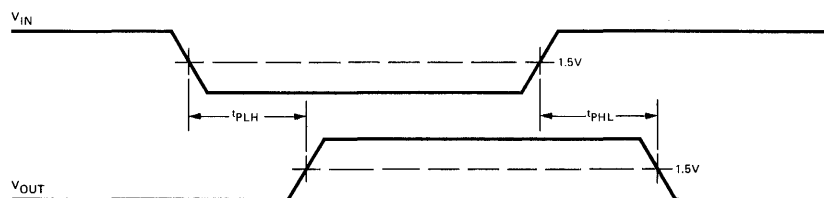

Fig. 1

5

FAIRCHILD TTL/SSI • 9N00/5400, 7400

QUAD 2-INPUT NAND GATE

LOGIC AND CONNECTION DIAGRAM

DIP (TOP VIEW)

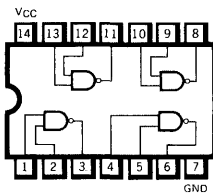

Positive logic: $Y = \overline{AB}$

FLATPAK (TOP VIEW)

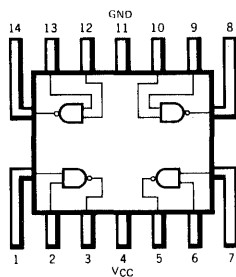

SCHEMATIC DIAGRAM (EACH GATE)

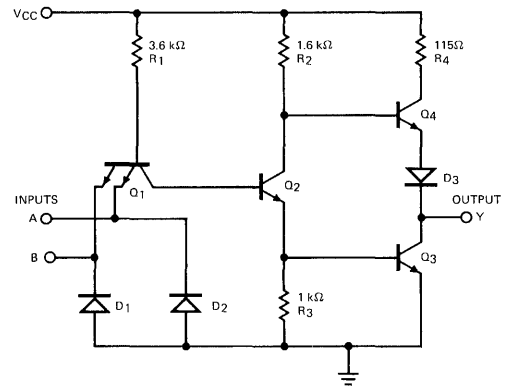

Component values shown are typical

RECOMMENDED OPERATING CONDITIONS

PARAMETER	9N00XM/5400XM			9N00XC/7400XC			UNITS
	MIN.	TYP.	MAX.	MIN.	TYP.	MAX.	
Supply Voltage V_{CC}	4.5	5.0	5.5	4.75	5.0	5.25	Volts
Operating Free-Air Temperature Range	-55	25	125	0	25	70	°C
Normalized Fan-Out from Each Output, N			10			10	U.L.

X = package type; F for Flatpak, D for Ceramic Dip, P for Plastic Dip. See Packaging Information Section for packages available on this product.

ELECTRICAL CHARACTERISTICS OVER OPERATING TEMPERATURE RANGE (Unless Otherwise Noted)

SYMBOL	PARAMETER	LIMITS			UNITS	TEST CONDITIONS (Note 1)	TEST FIGURE
		MIN.	TYP. (Note 2)	MAX.			
V_{IH}	Input HIGH Voltage	2.0			Volts	Guaranteed Input HIGH Voltage	1
V_{IL}	Input LOW Voltage			0.8	Volts	Guaranteed Input LOW Voltage	2
V_{OH}	Output HIGH Voltage	2.4	3.3		Volts	$V_{CC} = \text{MIN.}, I_{OH} = 0.4 \text{ mA}, V_{IN} = 0.8 \text{ V}$	2
V_{OL}	Output LOW Voltage		0.22	0.4	Volts	$V_{CC} = \text{MIN.}, I_{OL} = 16 \text{ mA}, V_{IN} = 2.0 \text{ V}$	1
I_{IH}	Input HIGH Current			40	μA	$V_{CC} = \text{MAX.}, V_{IN} = 2.4 \text{ V}$	Each Input 4
				1.0	mA	$V_{CC} = \text{MAX.}, V_{IN} = 5.5 \text{ V}$	
I_{IL}	Input LOW Current			-1.6	mA	$V_{CC} = \text{MAX.}, V_{IN} = 0.4 \text{ V}$, Each Input	3
I_{OS}	Output Short Circuit Current (Note 3)	-20		-55	mA	9N00/5400	$V_{CC} = \text{MAX.}$ 5
		-18		-55	mA	9N00/7400	
I_{CCH}	Supply Current HIGH		4.0	8.0	mA	$V_{CC} = \text{MAX.}, V_{IN} = 0 \text{ V}$	6
I_{CCL}	Supply Current LOW		12	22	mA	$V_{CC} = \text{MAX.}, V_{IN} = 5.0 \text{ V}$	6

SWITCHING CHARACTERISTICS ($T_A = 25^\circ\text{C}$)

SYMBOL	PARAMETER	LIMITS			UNITS	TEST CONDITIONS	TEST FIGURE
		MIN.	TYP.	MAX.			
t_{PLH}	Turn Off Delay Input to Output		11	22	ns	$V_{CC} = 5.0 \text{ V}$ $C_L = 15 \text{ pF}$ $R_L = 400\Omega$	A
t_{PHL}	Turn On Delay Input to Output		7.0	15	ns		

NOTES:

- (1) For conditions shown as MIN. or MAX., use the appropriate value specified under recommended operating conditions for the applicable device type.
- (2) Typical limits are at $V_{CC} = 5.0 \text{ V}$, 25°C .
- (3) Note more than one output should be shorted at a time.

QUAD 2-INPUT NAND GATE

LOGIC AND CONNECTION DIAGRAM

DIP (TOP VIEW)

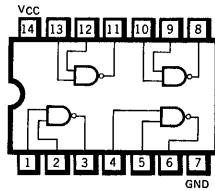

Positive logic: $Y = \overline{AB}$

SCHEMATIC DIAGRAM

(EACH GATE)

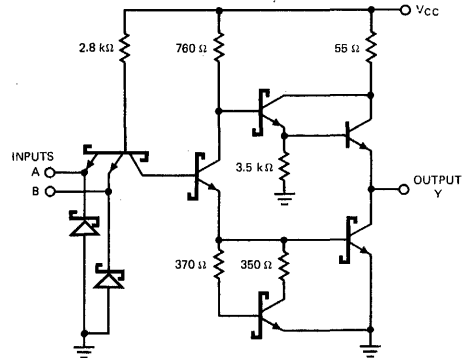

Component values shown are typical.

RECOMMENDED OPERATING CONDITIONS

PARAMETER	9S00XM/54S00XM			9S00XC/74S00XC			UNITS
	MIN.	TYP.	MAX.	MIN.	TYP.	MAX.	
Supply Voltage V_{CC}	4.5	5.0	5.5	4.75	5.0	5.25	Volts
Operating Free-Air Temperature Range	-55	25	125	0	25	75	°C
Input Loading for Each Input			1.25			1.25	U.L.

X = package type; F for Flatpak, D for Ceramic Dip, P for Plastic Dip. See Packaging Information Section for packages available on this product.

ELECTRICAL CHARACTERISTICS OVER OPERATING TEMPERATURE RANGE (Unless Otherwise Noted)

SYMBOL	PARAMETER	LIMITS			UNITS	TEST CONDITIONS (Note 1)
		MIN.	TYP. (Note 2)	MAX.		
V_{IH}	Input HIGH Voltage	2.0			Volts	Guaranteed Input HIGH Voltage
V_{IL}	Input LOW Voltage			0.8	Volts	Guaranteed Input LOW Voltage
V_{CD}	Input Clamp Diode Voltage		-0.65	-1.2	Volts	$V_{CC} = \text{MIN.}, I_{IN} = -18\text{mA}$
V_{OH}	Output HIGH Voltage	XM	2.5	3.4	Volts	$V_{CC} = \text{MIN.}, I_{OH} = -1.0\text{mA}, V_{IN} = 0.8\text{V}$
		XC	2.7	3.4		
V_{OL}	Output LOW Voltage		0.35	0.5	Volts	$V_{CC} = \text{MIN.}, I_{OL} = 20\text{mA}, V_{IN} = 2.0\text{V}$
I_{IH}	Input HIGH Current		1.0	50	μA	$V_{CC} = \text{MAX.}, V_{IN} = 2.7\text{V}$
				1.0	mA	$V_{CC} = \text{MAX.}, V_{IN} = 5.5\text{V}$
I_{IL}	Input LOW Current		-1.4	-2.0	mA	$V_{CC} = \text{MAX.}, V_{IN} = 0.5\text{V}$ Each Input
I_{OS}	Output Short Circuit Current (Note 3)	-40	-65	-100	mA	$V_{CC} = \text{MAX.}, V_{OUT} = 0\text{V}$
I_{CCH}	Supply Current HIGH		10.8	16.0	mA	$V_{CC} = \text{MAX.}, V_{IN} = 0\text{V}$
I_{CCL}	Supply Current LOW		25.2	36.0	mA	$V_{CC} = \text{MAX.}, \text{Inputs Open}$

SWITCHING CHARACTERISTICS ($T_A = 25^\circ\text{C}$)

SYMBOL	PARAMETER	LIMITS			UNITS	TEST CONDITIONS	TEST FIGURES
		MIN.	TYP.	MAX.			
t_{PLH}	Turn Off Delay Input to Output	2.0	3.0	4.5	ns	$V_{CC} = 5.0\text{V}$	DD
t_{PHL}	Turn On Delay Input to Output	2.0	3.0	5.0	ns	$C_L = 15\text{pF}$	

NOTES:

- (1) For conditions shown as MIN. or MAX., use the appropriate value specified under recommended operating conditions for the applicable device type.
- (2) Typical limits are at $V_{CC} = 5.0\text{V}, 25^\circ\text{C}$.
- (3) Not more than one output should be shorted at a time.

FAIRCHILD HIGH SPEED TTL/SSI • 9H01/54H01, 74H01

QUAD 2-INPUT NAND GATE (WITH OPEN-COLLECTOR OUTPUT)

LOGIC AND CONNECTION DIAGRAM

DIP (TOP VIEW)

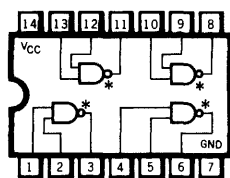

* Open collector

Positive logic: $Y = \overline{AB}$

FLATPAK (Top View)

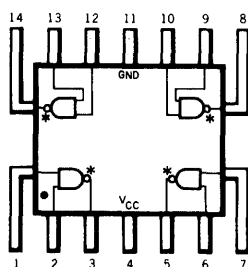

* Open collector

SCHEMATIC DIAGRAM (EACH GATE)

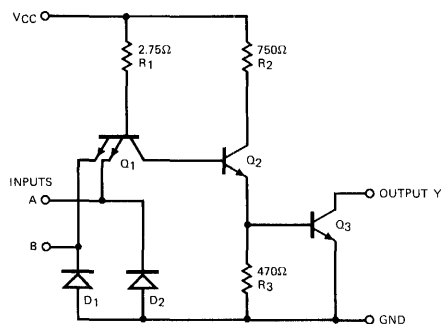

Component values shown are typical.

RECOMMENDED OPERATING CONDITIONS

PARAMETER	9H01XM/54H01XM			9H01XC/74H01XC			UNITS
	MIN.	TYP.	MAX.	MIN.	TYP.	MAX.	
Supply Voltage V_{CC}	4.5	5.0	5.5	4.75	5.0	5.25	Volts
Operating Free-Air Temperature Range	-55	25	125	0	25	70	°C
Input Loading for Each Input			1.25			1.25	U.L.

X = package type; F for Flatpak, D for Ceramic Dip, P for Plastic Dip. See Packaging Information Section for packages available on this product.

ELECTRICAL CHARACTERISTICS OVER OPERATING TEMPERATURE RANGE (Unless Otherwise Noted)

SYMBOL	PARAMETER	LIMITS			UNITS	TEST CONDITIONS (Note 1)	TEST FIGURE	
		MIN.	TYP. (Note 2)	MAX.				
V_{IH}	Input HIGH Voltage	2.0			Volts	Guaranteed Input HIGH Voltage	1	
V_{IL}	Input LOW Voltage			0.8	Volts	Guaranteed Input LOW Voltage	7	
I_{OH}	Output HIGH Current			0.25	mA	$V_{CC} = \text{MIN.}, V_{OH} = 5.5 \text{ V}, V_{IN} = 0.8 \text{ V}$	7	
V_{OL}	Output LOW Voltage			0.4	Volts	$V_{CC} = \text{MIN.}, I_{OL} = 20 \text{ mA}, V_{IN} = 2.0 \text{ V}$	1	
I_{IH}	Input HIGH Current			50	μA	$V_{CC} = \text{MAX.}, V_{IN} = 2.4 \text{ V}$	Each Input	4
				1.0	mA	$V_{CC} = \text{MAX.}, V_{IN} = 5.5 \text{ V}$		
I_{IL}	Input LOW Current			-2.0	mA	$V_{CC} = \text{MAX.}, V_{IN} = 0.4 \text{ V}$, Each Input	3	
I_{CCH}	Supply Current HIGH		6.8	10	mA	$V_{CC} = \text{MAX.}, V_{IN} = 0 \text{ V}$	6	
I_{CCL}	Supply Current LOW		26	40	mA	$V_{CC} = \text{MAX.}, V_{IN} = 4.5 \text{ V}$	6	

SWITCHING CHARACTERISTICS ($T_A = 25^\circ\text{C}$)

SYMBOL	PARAMETER	MIN.	LIMITS		UNITS	TEST CONDITIONS	TEST FIGURE
			TYP.	MAX.			
t_{PLH}	Turn Off Delay Input to Output		10	15	ns	$V_{CC} = 5.0 \text{ V}$ $C_L = 25 \text{ pF}$ $R_L = 280 \Omega$	T
t_{PHL}	Turn On Delay Input to Output		7.5	12	ns		

NOTES:

(1) For conditions shown as MIN. or MAX., use the appropriate value specified under recommended operating conditions for the applicable device type.

(2) Typical limits are at $V_{CC} = 5.0 \text{ V}, 25^\circ\text{C}$.

FAIRCHILD TTL/SSI • 9N01/5401, 7401

QUAD 2-INPUT NAND GATE
(WITH OPEN-COLLECTOR OUTPUT)

LOGIC AND CONNECTION DIAGRAM

DIP (TOP VIEW)

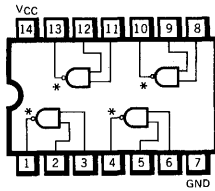

*OPEN COLLECTOR

Positive logic: $Y = \overline{AB}$

FLATPAK (TOP VIEW)

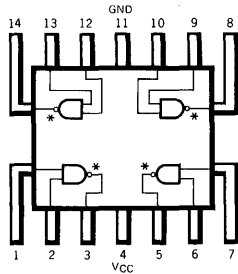

*OPEN COLLECTOR

SCHEMATIC DIAGRAM
(EACH GATE)

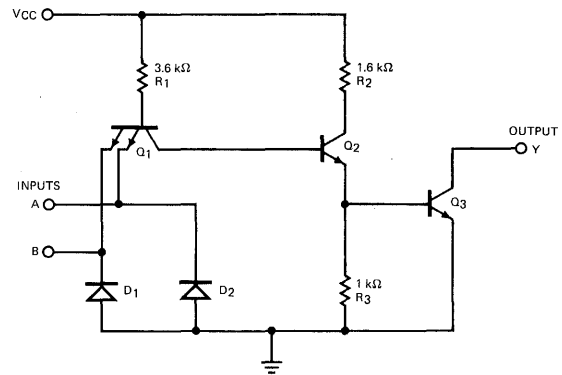

Component values shown are typical.

RECOMMENDED OPERATING CONDITIONS

PARAMETER	9N01XM/5401XM			9N01XC/7401XC			UNITS
	MIN.	TYP.	MAX.	MIN.	TYP.	MAX.	
Supply Voltage V_{CC}	4.5	5.0	5.5	4.75	5.0	5.25	Volts
Operating Free-Air Temperature Range	-55	25	125	0	25	70	°C
Normalized Fan-Out from Each Output, N			10			10	U.L.

X = package type; F for Flatpak, D for Ceramic Dip, P for Plastic Dip. See Packaging Information Section for packages available on this product.

ELECTRICAL CHARACTERISTICS OVER OPERATING TEMPERATURE RANGE (Unless Otherwise Noted)

SYMBOL	PARAMETER	LIMITS			UNITS	TEST CONDITIONS (Note 1)	TEST FIGURE	
		MIN.	TYP. (Note 2)	MAX.				
V_{IH}	Input HIGH Voltage	2.0			Volts	Guaranteed Input HIGH Voltage	1	
V_{IL}	Input LOW Voltage			0.8	Volts	Guaranteed Input LOW Voltage	7	
I_{OH}	Output HIGH Current			0.25	mA	$V_{CC} = \text{MIN.}, V_{OH} = 5.5 \text{ V}, V_{IL} = 0.8 \text{ V}$	7	
V_{OL}	Output LOW Voltage			0.4	Volts	$V_{CC} = \text{MIN.}, I_{OL} = 16 \text{ mA}, V_{IN} = 2.0 \text{ V}$ (On Level)	1	
I_{IH}	Input HIGH Current			40	μA	$V_{CC} = \text{MAX.}, V_{IN} = 2.4 \text{ V}$	Each Input	4
				1.0	mA	$V_{CC} = \text{MAX.}, V_{IN} = 5.5 \text{ V}$		
I_{IL}	Input LOW Current			-1.6	mA	$V_{CC} = \text{MAX.}, V_{IN} = 0.4 \text{ V}$, Each Input	3	
I_{CCH}	Supply Current HIGH		4.0	8.0	mA	$V_{CC} = \text{MAX.}, V_{IN} = 0 \text{ V}$	6	
I_{CCL}	Supply Current LOW		12	22	mA	$V_{CC} = \text{MAX.}, V_{IN} = 5.0 \text{ V}$	6	

SWITCHING CHARACTERISTICS ($T_A = 25^\circ\text{C}$)

SYMBOL	PARAMETER	LIMITS			UNITS	TEST CONDITIONS	TEST FIGURE
		MIN.	TYP.	MAX.			
t_{PLH}	Turn Off Delay Input to Output		35	45	ns	$R_L = 4.0 \text{ k}\Omega$	A
t_{PHL}	Turn On Delay Input to Output		8.0	15	ns	$R_L = 400\Omega$	

NOTES:

(1) For conditions shown as MIN. or MAX., use the appropriate value specified under recommended operating conditions for the applicable device type.

(2) Typical limits are at $V_{CC} = 5.0 \text{ V}, 25^\circ\text{C}$.

QUAD 2-INPUT NOR GATE

LOGIC AND CONNECTION DIAGRAM

DIP (TOP VIEW)

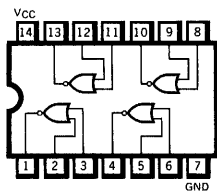

Positive logic: $Y = \overline{A+B}$

FLATPAK (TOP VIEW)

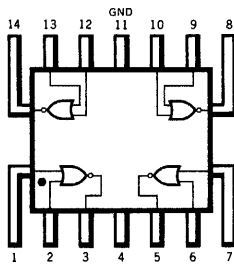

SCHEMATIC DIAGRAM (EACH GATE)

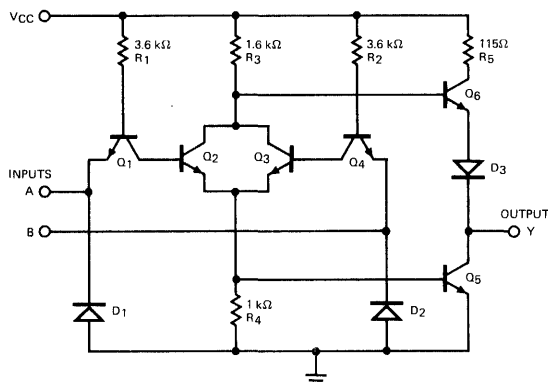

Component values shown are typical.

RECOMMENDED OPERATING CONDITIONS

PARAMETER	9N02XM/5402XM			9N02XC/7402XC			UNITS
	MIN.	TYP.	MAX.	MIN.	TYP.	MAX.	
Supply Voltage V_{CC}	4.5	5.0	5.5	4.75	5.0	5.25	Volts
Operating Free-Air Temperature Range	-55	25	125	0	25	70	$^{\circ}C$
Normalized Fan-Out from Each Output, N			10			10	U.L.

X = package type; F for Flatpak, D for Ceramic Dip, P for Plastic Dip. See Packaging Information Section for packages available on this product.

ELECTRICAL CHARACTERISTICS OVER OPERATING TEMPERATURE RANGE (Unless Otherwise Noted)

SYMBOL	PARAMETER	LIMITS			UNITS	TEST CONDITIONS (Note 1)	TEST FIGURE
		MIN.	TYP. (Note 2)	MAX.			
V_{IH}	Input HIGH Voltage	2.0			Volts	Guaranteed Input HIGH Voltage	8
V_{IL}	Input LOW Voltage			0.8	Volts	Guaranteed Input LOW Voltage	9
V_{OH}	Output HIGH Voltage	2.4	3.3		Volts	$V_{CC} = \text{MIN.}, I_{OH} = -0.4 \text{ mA}, V_{IN} = 0.8 \text{ V}$	9
V_{OL}	Output LOW Voltage		0.22	0.4	Volts	$V_{CC} = \text{MIN.}, I_{OL} = 16 \text{ mA}, V_{IN} = 2.0 \text{ V}$	10
I_{IH}	Input HIGH Current			40	μA	$V_{CC} = \text{MAX.}, V_{IN} = 2.4 \text{ V}$	Each Input 12
				1.0	mA	$V_{CC} = \text{MAX.}, V_{IN} = 5.5 \text{ V}$	
I_{IL}	Input LOW Current			-1.6	mA	$V_{CC} = \text{MAX.}, V_{IN} = 0.4 \text{ V}$, Each Input	11
I_{OS}	Output Short Circuit Current (Note 3)	-20		-55	mA	9N02/5402	$V_{CC} = \text{MAX.}$ 13
		18		-55	mA	9N02/7402	
I_{CCH}	Supply Current HIGH		8.0	16	mA	$V_{CC} = \text{MAX.}, V_{IN} = 0 \text{ V}$	14
I_{CCL}	Supply Current LOW		14	27	mA	$V_{CC} = \text{MAX.}, V_{IN} = 5.0 \text{ V}$	14

SWITCHING CHARACTERISTICS ($T_A = 25^{\circ}C$)

SYMBOL	PARAMETER	LIMITS			UNITS	TEST CONDITIONS	TEST FIGURE
		MIN.	TYP.	MAX.			
t_{PLH}	Turn Off Delay Input to Output		12	22	ns	$V_{CC} = 5.0 \text{ V}$ $C_L = 15 \text{ pF}$ $R_L = 400\Omega$	A
t_{PHL}	Turn On Delay Input to Output		8.0	15	ns		

NOTES:

- (1) For conditions shown as MIN. or MAX., use the appropriate value specified under recommended operating conditions for the applicable device type.
- (2) Typical limits are at $V_{CC} = 5.0 \text{ V}, 25^{\circ}C$.
- (3) Not more than one output should be shorted at a time.

FAIRCHILD TTL/SSI • 9N03/5403, 7403

QUAD 2-INPUT NAND GATE
(WITH OPEN-COLLECTOR OUTPUT)

LOGIC AND CONNECTION DIAGRAM

DIP (TOP VIEW)

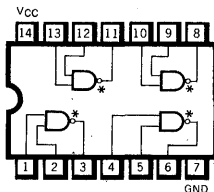

*OPEN COLLECTOR

Positive logic: $Y = \overline{AB}$

SCHEMATIC DIAGRAM
(EACH GATE)

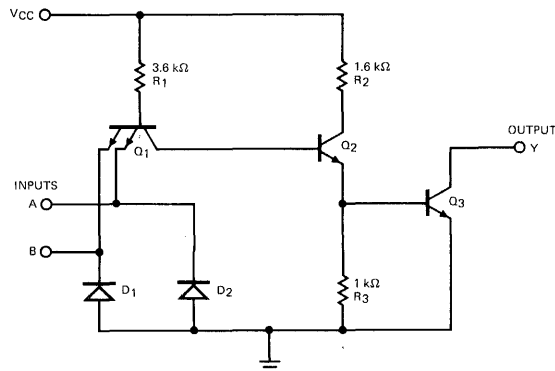

Component values shown are typical.

RECOMMENDED OPERATING CONDITIONS

PARAMETER	9N03XM/5403XM			9N03XC/7403XC			UNITS
	MIN.	TYP.	MAX.	MIN.	TYP.	MAX.	
Supply Voltage V_{CC}	4.5	5.0	5.5	4.75	5.0	5.25	Volts
Operating Free-Air Temperature Range	-55	25	125	0	25	70	°C
Normalized Fan-Out from Each Output, N			10			10	U.L.

X = package type; F for Flatpak, D for Ceramic Dip, P for Plastic Dip. See Packaging Information Section for packages available on this product.

ELECTRICAL CHARACTERISTICS OVER OPERATING TEMPERATURE RANGE (Unless Otherwise Noted)

SYMBOL	PARAMETER	LIMITS			UNITS	TEST CONDITIONS (Note 1)	TEST FIGURE	
		MIN.	TYP. (Note 2)	MAX.				
V_{IH}	Input HIGH Voltage	2.0			Volts	Guaranteed Input HIGH Voltage	1	
V_{IL}	Input LOW Voltage			0.8	Volts	Guaranteed Input LOW Voltage	7	
I_{OH}	Output HIGH Current			0.25	mA	$V_{CC} = \text{MIN.}, V_{OH} = 5.5 \text{ V}, V_{IN} = 0.8 \text{ V}$	7	
V_{OL}	Output LOW Voltage			0.4	Volts	$V_{CC} = \text{MIN.}, I_{OL} = 16 \text{ mA}, V_{IN} = 2.0 \text{ V}$ (On Level)	1	
I_{IH}	Input HIGH Current			40	μA	$V_{CC} = \text{MAX.}, V_{IN} = 2.4 \text{ V}$	Each Input	4
				1.0	mA	$V_{CC} = \text{MAX.}, V_{IN} = 5.5 \text{ V}$		
I_{IL}	Input LOW Current			-1.6	mA	$V_{CC} = \text{MAX.}, V_{IN} = 0.4 \text{ V}$	Each Input	3
I_{CCH}	Supply Current HIGH		4.0	8.0	mA	$V_{CC} = \text{MAX.}, V_{IN} = 0 \text{ V}$		6
I_{CCL}	Supply Current LOW		12	22	mA	$V_{CC} = \text{MAX.}, V_{IN} = 5.0 \text{ V}$		6

SWITCHING CHARACTERISTICS ($T_A = 25^\circ\text{C}$)

SYMBOL	PARAMETER	MIN.	LIMITS TYP.	MAX.	UNITS	TEST CONDITIONS		TEST FIGURE
						R_L	C_L	
t_{PLH}	Turn Off Delay Input to Output		35	45	ns	$R_L = 4.0 \text{ k}\Omega$	$V_{CC} = 5.0 \text{ V}$ $C_L = 15 \text{ pF}$	A
t_{PHL}	Turn On Delay Input to Output		8.0	15	ns	$R_L = 400 \Omega$		

NOTES:

(1) For conditions shown as MIN. or MAX., use the appropriate value specified under recommended operating conditions for the applicable device type.

(2) Typical limits are at $V_{CC} = 5.0 \text{ V}, 25^\circ\text{C}$.

FAIRCHILD SUPER HIGH SPEED TTL/SSI • 9S03/54S03, 74S03

QUAD 2-INPUT NAND GATE
(WITH OPEN-COLLECTOR OUTPUT)

LOGIC AND CONNECTION DIAGRAM

DIP (TOP VIEW)

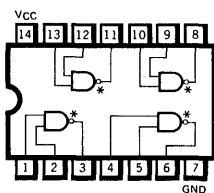

* OPEN COLLECTOR

Positive logic: $Y = \overline{AB}$

SCHEMATIC DIAGRAM

(EACH GATE)

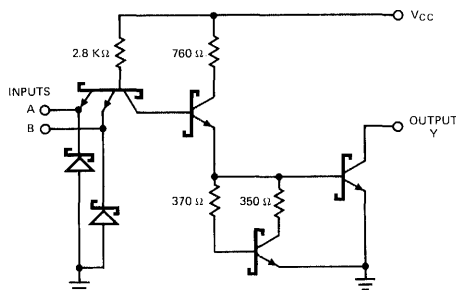

Component values shown are typical.

RECOMMENDED OPERATING CONDITIONS

PARAMETER	† 9S03XM/54S03XM			9S03XC/74S03XC			UNITS
	MIN.	TYP.	MAX.	MIN.	TYP.	MAX.	
Supply Voltage V_{CC}	4.5	5.0	5.5	4.75	5.0	5.25	Volts
Operating Free-Air Temperature Range	-55	25	125	0	25	75	°C
Input Loading for Each Input			1.25			1.25	U.L.

X = package type; F for Flatpak, D for Ceramic Dip, P for Plastic Dip. See Packaging Information Section for packages available on this product.

ELECTRICAL CHARACTERISTICS OVER OPERATING TEMPERATURE RANGE (Unless Otherwise Noted)

SYMBOL	PARAMETER	LIMITS			UNITS	TEST CONDITIONS (Note 1)
		MIN.	TYP. (Note 2)	MAX.		
V_{IH}	Input HIGH Voltage	2.0			Volts	Guaranteed Input HIGH Voltage
V_{IL}	Input LOW Voltage			0.8	Volts	Guaranteed Input LOW Voltage
V_{CD}	Input Clamp Diode Voltage		-0.65	-1.2	Volts	$V_{CC} = \text{MIN.}, I_{IN} = -18\text{mA}$
I_{OH}	Output HIGH Current		0.1	250	μA	$V_{CC} = \text{MIN.}, V_{OH} = 5.5\text{V}, V_{IN} = 0.8\text{V}$
V_{OL}	Output LOW Voltage		0.35	0.5	Volts	$V_{CC} = \text{MIN.}, I_{OL} = 20\text{mA}, V_{IN} = 2.0\text{V}$
I_{IH}	Input HIGH Current		1.0	50	μA	$V_{CC} = \text{MAX.}, V_{IN} = 2.7\text{V}$
				1.0	mA	$V_{CC} = \text{MAX.}, V_{IN} = 5.5\text{V}$
I_{IL}	Input LOW Current		-1.4	-2.0	mA	$V_{CC} = \text{MAX.}, V_{IN} = 0.5\text{V}$ Each Input
I_{CCH}	Supply Current HIGH		6.0	13.2	mA	$V_{CC} = \text{MAX.}, V_{IN} = 0\text{V}$
I_{CCL}	Supply Current LOW		25.2	36.0	mA	$V_{CC} = \text{MAX.}, \text{Inputs Open}$

SWITCHING CHARACTERISTICS ($T_A = 25^\circ\text{C}$)

SYMBOL	PARAMETER	LIMITS			UNITS	TEST CONDITIONS	TEST FIGURES
		MIN.	TYP.	MAX.			
t_{PLH}	Turn Off Delay Input to Output	2.0	5.0	7.5	ns	$V_{CC} = 5.0\text{V}$	EE
t_{PHL}	Turn On Delay Input to Output	2.0	4.5	7.0	ns	$C_L = 15\text{pF}$	

NOTES:

- (1) For conditions shown as MIN. or MAX., use the appropriate value specified under recommended operating conditions for the applicable device type.
- (2) Typical limits are at $V_{CC} = 5.0\text{V}, 25^\circ\text{C}$.

FAIRCHILD HIGH SPEED TTL/SSI • 9H04/54H04, 74H04

HEX INVERTER

LOGIC AND CONNECTION DIAGRAM

DIP (TOP VIEW)

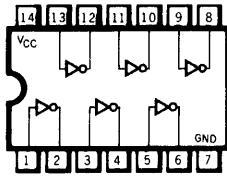

Positive logic: $Y = \bar{A}$

FLATPAK (TOP VIEW)

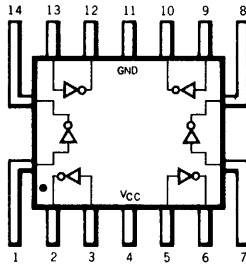

SCHEMATIC DIAGRAM (EACH INVERTER)

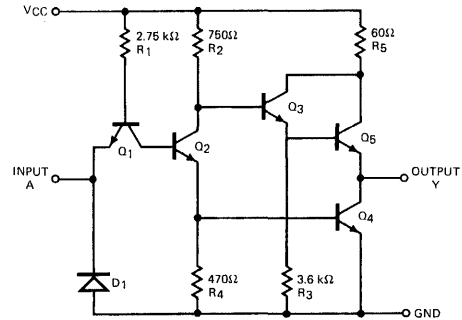

Component values shown are typical.

RECOMMENDED OPERATING CONDITIONS

PARAMETER	9H04XM/54H04XM			9H04XC/74H04XC			UNITS
	MIN.	TYP.	MAX.	MIN.	TYP.	MAX.	
Supply Voltage V_{CC}	4.5	5.0	5.5	4.75	5.0	5.25	Volts
Operating Free-Air Temperature Range	-55	25	125	0	25	70	$^{\circ}\text{C}$
Input Loading for Each Input			1.25			1.25	U.L.

X = package type; F for Flatpak, D for Ceramic Dip, P for Plastic Dip. See Packaging Information Section for packages available on this product.

ELECTRICAL CHARACTERISTICS OVER OPERATING TEMPERATURE RANGE (Unless Otherwise Noted)

SYMBOL	PARAMETER	LIMITS			UNITS	TEST CONDITIONS (Note 1)	TEST FIGURE
		MIN.	TYP. (Note 2)	MAX.			
V_{IH}	Input HIGH Voltage	2.0			Volts	Guaranteed Input HIGH Voltage	15
V_{IL}	Input LOW Voltage			0.8	Volts	Guaranteed Input LOW Voltage	16
V_{OH}	Output HIGH Voltage	2.4			Volts	$V_{CC} = \text{MIN.}, I_{OH} = -0.5 \text{ mA}, V_{IN} = 0.8 \text{ V}$	16
V_{OL}	Output LOW Voltage			0.4	Volts	$V_{CC} = \text{MIN.}, I_{OL} = 20 \text{ mA}, V_{IN} = 2.0 \text{ V}$	15
I_{IH}	Input HIGH Current			50	μA	$V_{CC} = \text{MAX.}, V_{IN} = 2.4 \text{ V}$	18
				1.0	mA	$V_{CC} = \text{MAX.}, V_{IN} = 5.5 \text{ V}$	
I_{IL}	Input LOW Current			-2.0	mA	$V_{CC} = \text{MAX.}, V_{IN} = 0.4 \text{ V}$	18
I_{OS}	Output Short Circuit Current (Note 3)	-40		-100	mA	$V_{CC} = \text{MAX.}$	19
I_{CCH}	Supply Current HIGH		16	26	mA	$V_{CC} = \text{MAX.}, V_{IN} = 0 \text{ V}$	20
I_{CCL}	Supply Current LOW		40	58	mA	$V_{CC} = \text{MAX.}, V_{IN} = 4.5 \text{ V}$	20

SWITCHING CHARACTERISTICS ($T_A = 25^{\circ}\text{C}$)

SYMBOL	PARAMETER	LIMITS			UNITS	TEST CONDITIONS	TEST FIGURE
		MIN.	TYP.	MAX.			
t_{PLH}	Turn Off Delay Input to Output		6.5	10	ns	$V_{CC} = 5.0 \text{ V}$ $C_L = 25 \text{ pF}$ $R_L = 280 \Omega$	T
t_{PHL}	Turn On Delay Input to Output		9.0	13	ns		

NOTES:

(1) For conditions shown as MIN. or MAX., use the appropriate value specified under recommended operating conditions for the applicable device type.

(2) Typical limits are at $V_{CC} = 5.0 \text{ V}, 25^{\circ}\text{C}$.

(3) Not more than one output should be shorted at a time, and duration of short-circuit test should not exceed 1 second.

LPTTL/SSI 9L04

LOW POWER HEX INVERTER

DESCRIPTION – The low power TTL/SSI 9L04 consists of six TTL gates, each performing a single inversion function. Designed for low power, medium speed operation, the 9L04 is very useful where a number of complement signals are desired simultaneously.

- TYPICAL PROPAGATION DELAY OF 20 ns
- INPUT CLAMP DIODES LIMIT HIGH SPEED TERMINATION EFFECTS
- ALL CERAMIC "HERMETIC" 14-LEAD DUAL IN-LINE AND FLAT PACKAGES
- TTL COMPATIBLE

PIN NAMES

INPUTS (Pins 1, 3, 5, 9, 11, 13)
 OUTPUTS (Pins 2, 4, 6, 8, 10, 12)

LOADING

HIGH	LOW
0.5 U.L.	0.25 U.L.
10 U.L.	2.5 U.L.

LOGIC SYMBOL

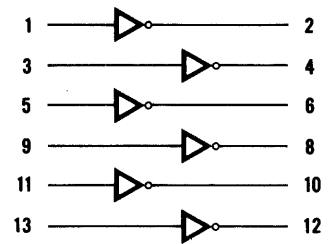

V_{CC} = Pin 14
 GND = Pin 7

CONNECTION DIAGRAMS

DIP (Top View)

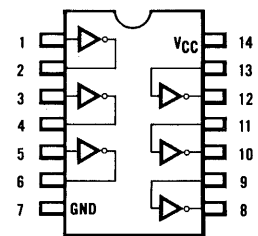

FLATPAK (Top View)

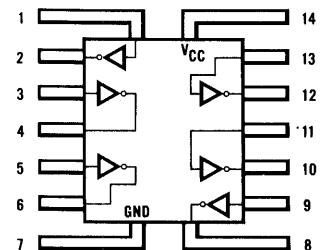

SCHEMATIC DIAGRAM

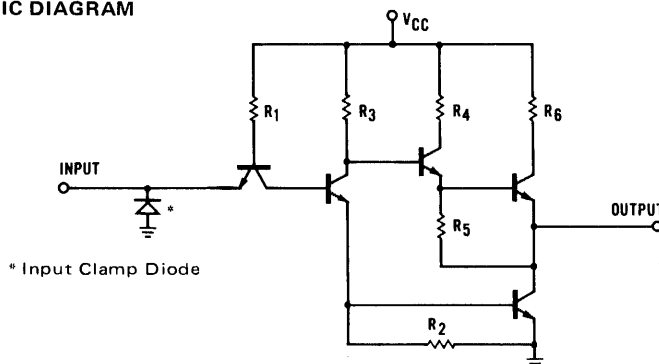

* Input Clamp Diode

TYPICAL RESISTOR VALUES

$R_1 = 16 \text{ k}\Omega$ $R_3 = 6 \text{ k}\Omega$ $R_5 = 16 \text{ k}\Omega$
 $R_2 = 5 \text{ k}\Omega$ $R_4 = 600 \Omega$ $R_6 = 320 \Omega$

1 Unit Load (U.L.) = 40 μA HIGH/1.6 mA LOW.

FAIRCHILD LPTTL/SSI 9L04

ABSOLUTE MAXIMUM RATINGS (above which the useful life may be impaired)

Storage Temperature	-65°C to +150°C
Temperature (Ambient) Under Bias	-55°C to +125°C
V _{CC} Pin Potential to Ground Pin	-0.5 V to +7.0 V
*Input Voltage (dc)	-0.5 V to +5.5 V
*Input Current (dc)	-30 mA to +5.0 mA
Voltage Applied to Outputs (Output HIGH)	-0.5 V to +V _{CC} value
Output Current (dc) (Output LOW)	+30 mA

*Either Input Voltage limit or Input Current limit is sufficient to protect the inputs.

GUARANTEED OPERATING RANGES

PART NUMBER	SUPPLY VOLTAGE (V _{CC})			TEMPERATURE
	MIN.	TYP.	MAX.	
9L04XM	4.5 V	5.0 V	5.5 V	-55°C to 125°C
9L04XC	4.75 V	5.0 V	5.25 V	0°C to 75°C

X = package type; F for Flatpak, D for Ceramic Dip, P for Plastic Dip. See Packaging Information Section for packages available on this product.

ELECTRICAL CHARACTERISTICS OVER OPERATING TEMPERATURE RANGE (UNLESS OTHERWISE NOTED) (See Notes 1 & 2)

SYMBOL	PARAMETER	LIMITS			UNITS	CONDITIONS
		MIN.	TYP. Note 3	MAX.		
V _{OH}	Output HIGH Voltage	2.4	3.6		Volts	V _{CC} = MIN., I _{OH} = -0.4 mA, V _{IN} = V _{IL}
V _{OL}	Output LOW Voltage		0.1	0.3	Volts	V _{CC} = MIN., I _{OL} = 4.0 mA, V _{IN} = V _{IH}
V _{IH}	Input HIGH Voltage	2.0			Volts	Guaranteed input logical HIGH voltage for all inputs
V _{IL}	Input LOW Voltage			0.7	Volts	Guaranteed input logical LOW voltage for all inputs
I _{IL}	Input LOW Current		-0.25	-0.4	mA	V _{CC} = MAX., V _{IN} = 0.3 V
I _{IH}	Input HIGH Current		2.0	20	μA	V _{CC} = MAX., V _{IN} = 2.4 V
				1.0	mA	V _{CC} = MAX., V _{IN} = 5.5 V
I _{SC} (Note 4)	Output Short Circuit Current	-10	-22	-40	mA	V _{CC} = MAX., V _{OUT} = 0.00 V, Inputs grounded
I _{CC}	Power Supply Current per Gate		0.9	1.56	mA	V _{CC} = MAX., Input HIGH
			0.28	0.45	mA	V _{CC} = MAX., Input LOW

- NOTES: 1. Conditions for testing, not shown in the Table, are chosen to guarantee operation under "worst case" conditions.
 2. The specified LIMITS represent the "worst case" value for the parameter. Since these "worst case" values normally occur at the temperature and supply voltage extremes, additional noise immunity and guard banding can be achieved by decreasing the allowable system operating ranges.
 3. Typical limits are at V_{CC} = 5.0 V, 25°C, and max. loading.
 4. Not more than one output should be shorted at a time.

SWITCHING CHARACTERISTICS (T_A = 25°C)

SYMBOL	PARAMETER	LIMITS			UNITS	CONDITIONS
		MIN.	TYP.	MAX.		
t _{PLH}	Turn Off Delay Input to Output		15		ns	V _{CC} = 5.0V See Fig. 1
t _{PHL}	Turn On Delay Input to Output		25		ns	C _L = 15 pF

SWITCHING TIME WAVEFORM

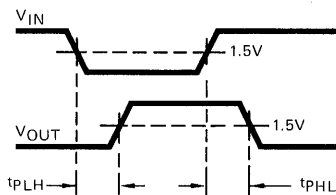

Fig. 1

5

HEX INVERTER

LOGIC AND CONNECTION DIAGRAM

DIP (TOP VIEW)

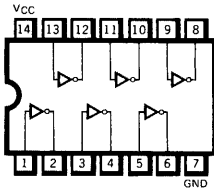

Positive logic: $Y = \bar{A}$

FLATPAK (TOP VIEW)

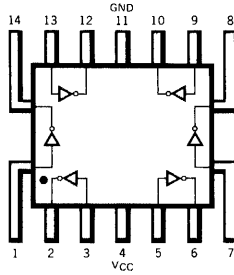

SCHEMATIC DIAGRAM (EACH INVERTER)

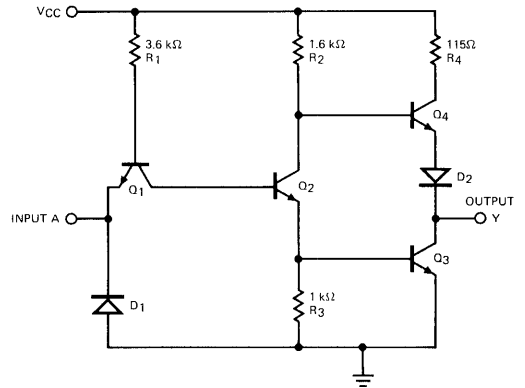

Component values shown are typical.

RECOMMENDED OPERATING CONDITIONS

PARAMETER	9N04XM/5404XM			9N04XC/7404XC			UNITS
	MIN.	TYP.	MAX.	MIN.	TYP.	MAX.	
Supply Voltage V_{CC}	4.5	5.0	5.5	4.75	5.0	5.25	Volts
Operating Free-Air Temperature Range	-55	25	125	0	25	70	°C
Normalized Fan-Out from Each Output, N			10			10	U.L.

X = package type; F for Flatpak, D for Ceramic Dip, P for Plastic Dip. See Packaging Information Section for packages available on this product.

ELECTRICAL CHARACTERISTICS OVER OPERATING TEMPERATURE RANGE (Unless Otherwise Noted)

SYMBOL	PARAMETER	LIMITS			UNITS	TEST CONDITIONS (Note 1)	TEST FIGURE
		MIN.	TYP. (Note 2)	MAX.			
V_{IH}	Input HIGH Voltage	2.0			Volts	Guaranteed Input HIGH Voltage	15
V_{IL}	Input LOW Voltage			0.8	Volts	Guaranteed Input LOW Voltage	16
V_{OH}	Output HIGH Voltage	2.4	3.3		Volts	$V_{CC} = \text{MIN.}, I_{OH} = -0.4 \text{ mA}, V_{IN} = 0.8 \text{ V}$	16
V_{OL}	Output LOW Voltage		0.22	0.4	Volts	$V_{CC} = \text{MIN.}, I_{OL} = 16 \text{ mA}, V_{IN} = 2.0 \text{ V}$	15
I_{IH}	Input HIGH Current			40	μA	$V_{CC} = \text{MAX.}, V_{IN} = 2.4 \text{ V}$	18
					1.0	mA	
I_{IL}	Input LOW Current			-1.6	mA	$V_{CC} = \text{MAX.}, V_{IN} = 0.4 \text{ V}$	18
I_{OS}	Output Short Circuit Current (Note 3)	-20		-55	mA	9N04/5404	19
		-18		-55	mA	9N04/7404	
I_{CCH}	Supply Current HIGH		6.0	12	mA	$V_{CC} = \text{MAX.}, V_{IN} = 0 \text{ V}$	20
I_{CCL}	Supply Current LOW		18	33	mA	$V_{CC} = \text{MAX.}, V_{IN} = 5.0 \text{ V}$	20

SWITCHING CHARACTERISTICS ($T_A = 25^\circ\text{C}$)

SYMBOL	PARAMETER	LIMITS			UNITS	TEST CONDITIONS	TEST FIGURE
		MIN.	TYP.	MAX.			
tPLH	Turn Off Delay Input to Output		12	22	ns	$V_{CC} = 5.0 \text{ V}$ $C_L = 15 \text{ pF}$	A
tPHL	Turn On Delay Input to Output		8.0	15	ns	$R_L = 400\Omega$	

NOTES:

(1) For conditions shown as MIN. or MAX., use the appropriate value specified under recommended operating conditions for the applicable device type.

(2) Typical limits are at $V_{CC} = 5.0 \text{ V}, 25^\circ\text{C}$.

(3) Not more than one output should be shorted at a time.

HEX INVERTER

LOGIC AND CONNECTION DIAGRAM
DIP (TOP VIEW)

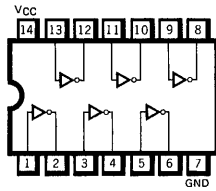

Positive logic: $Y = \bar{A}$

SCHEMATIC DIAGRAM
(EACH INVERTER)

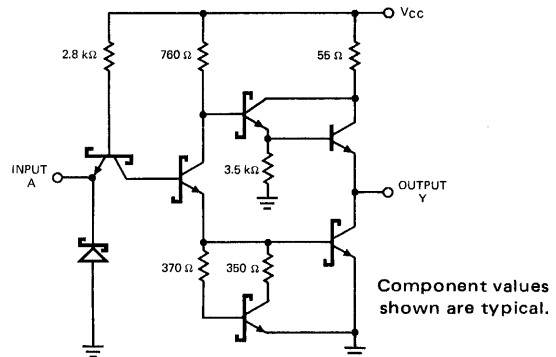

Component values shown are typical.

RECOMMENDED OPERATING CONDITIONS

PARAMETER	9S04XM/54S04XM 9S04AXM			9S04XC/74S04XC 9S04AXC			UNITS
	MIN.	TYP.	MAX.	MIN.	TYP.	MAX.	
Supply Voltage V_{CC}	4.5	5.0	5.5	4.75	5.0	5.25	Volts
Operating Free-Air Temperature Range	-55	25	125	0	25	75	°C
Input Loading for Each Input			1.25			1.25	U.L.

X = package type; F for Flatpak, D for Ceramic Dip, P for Plastic Dip. See Packaging Information Section for packages available on this product.

ELECTRICAL CHARACTERISTICS OVER OPERATING TEMPERATURE RANGE (Unless Otherwise Noted)

SYMBOL	PARAMETER	LIMITS			UNITS	TEST CONDITIONS (Note 1)
		MIN.	TYP. (Note 2)	MAX.		
V_{IH}	Input HIGH Voltage	2.0			Volts	Guaranteed Input HIGH Voltage
V_{IL}	Input LOW Voltage			0.8	Volts	Guaranteed Input LOW Voltage
V_{CD}	Input Clamp Diode Voltage		-0.65	-1.2	Volts	$V_{CC} = \text{MIN.}, I_{IN} = -18 \text{ mA}$
V_{OH}	Output HIGH Voltage	XM	2.5	3.4	Volts	$V_{CC} = \text{MIN.}, I_{OH} = -1.0 \text{ mA}, V_{IN} = 0.8 \text{ V}$
		XC	2.7	3.4		
V_{OL}	Output LOW Voltage		0.35	0.5	Volts	$V_{CC} = \text{MIN.}, I_{OL} = 20 \text{ mA}, V_{IN} = 2.0 \text{ V}$
I_{IH}	Input HIGH Current		1.0	50	μA	$V_{CC} = \text{MAX.}, V_{IN} = 2.7 \text{ V}$
				1.0	mA	$V_{CC} = \text{MAX.}, V_{IN} = 5.5 \text{ V}$
I_{IL}	Input LOW Current		-1.4	-2.0	mA	$V_{CC} = \text{MAX.}, V_{IN} = 0.5 \text{ V}$
I_{OS}	Output Short Circuit Current (Note 3)	-40	-65	-100	mA	$V_{CC} = \text{MAX.}, V_{OUT} = 0 \text{ V}$
I_{CCH}	Supply Current HIGH		16.2	24.0	mA	$V_{CC} = \text{MAX.}, V_{IN} = 0 \text{ V}$
I_{CCL}	Supply Current LOW		37.8	54.0	mA	$V_{CC} = \text{MAX.}, \text{Inputs Open}$

SWITCHING CHARACTERISTICS ($T_A = 25^\circ\text{C}$)

SYMBOL	PARAMETER		LIMITS			UNITS	TEST CONDITIONS	TEST FIGURES
			MIN.	TYP.	MAX.			
t_{PLH}	Turn Off Delay Input to Output	9S04	2.0	3.0	4.5	ns	$V_{CC} = 5.0 \text{ V}$	DD
		9S04A	1.0	2.5	3.5			
t_{PHL}	Turn On Delay Input to Output	9S04	2.0	3.0	5.0	ns	$C_L = 15 \text{ pF}$	
		9S04A	1.0	2.5	4.0			

NOTES:

(1) For conditions shown as MIN. or MAX., use the appropriate value specified under recommended operating conditions for the applicable device type.

(2) Typical limits are at $V_{CC} = 5.0 \text{ V}, 25^\circ\text{C}$.

(3) Not more than one output should be shorted at a time.

FAIRCHILD HIGH SPEED TTL/SSI • 9H05/54H05, 74H05

HEX INVERTER (WITH OPEN-COLLECTOR OUTPUT)

LOGIC AND CONNECTION DIAGRAM

DIP (TOP VIEW)

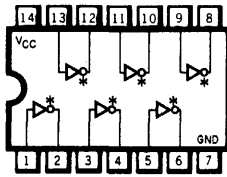

* OPEN COLLECTOR

Positive logic: $Y = \bar{A}$

FLATPAK (TOP VIEW)

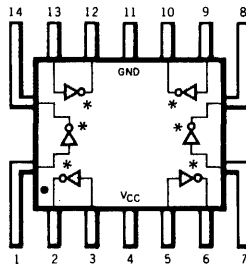

* OPEN COLLECTOR

SCHEMATIC DIAGRAM (EACH INVERTER)

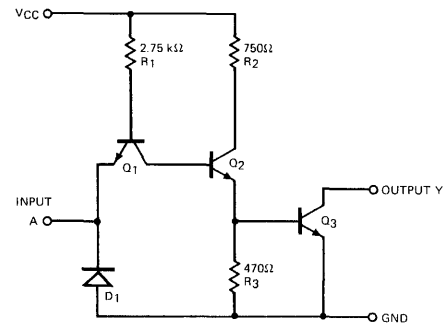

Component values shown are typical.

RECOMMENDED OPERATING CONDITIONS

PARAMETER	9H05XM/54H05XM			9H05XC/74H05XC			UNITS
	MIN.	TYP.	MAX.	MIN.	TYP.	MAX.	
Supply Voltage V_{CC}	4.5	5.0	5.5	4.75	5.0	5.25	Volts
Operating Free-Air Temperature Range	-55	25	125	0	25	70	$^{\circ}\text{C}$
Input Loading for Each Input			1.25			1.25	U.L.

X = package type; F for Flatpak, D for Ceramic Dip, P for Plastic Dip. See Packaging Information Section for packages available on this product.

ELECTRICAL CHARACTERISTICS OVER OPERATING TEMPERATURE RANGE (Unless Otherwise Noted)

SYMBOL	PARAMETER	LIMITS			UNITS	TEST CONDITIONS	TEST FIGURE
		MIN.	TYP. (Note 2)	MAX.			
V_{IH}	Input HIGH Voltage	2.0			Volts	Guaranteed Input HIGH Voltage	15
V_{IL}	Input LOW Voltage			0.8	Volts	Guaranteed Input LOW Voltage	17
I_{OH}	Output HIGH Current			0.25	mA	$V_{CC} = \text{MIN.}, V_{OH} = 5.5 \text{ V}, V_{IN} = 0.8 \text{ V}$	17
V_{OL}	Output LOW Voltage (On Level)			0.4	Volts	$V_{CC} = \text{MIN.}, I_{OL} = 20 \text{ mA}, V_{IN} = 2.0 \text{ V}$	15
I_{IH}	Input HIGH Current			50	μA	$V_{CC} = \text{MAX.}, V_{IN} = 2.4 \text{ V}$	18
				1.0	mA	$V_{CC} = \text{MAX.}, V_{IN} = 5.5 \text{ V}$	
I_{IL}	Input LOW Current			-2.0	mA	$V_{CC} = \text{MAX.}, V_{IN} = 0.4 \text{ V}$	18
I_{CCH}	Supply Current HIGH		16	26	mA	$V_{CC} = \text{MAX.}, V_{IN} = 0 \text{ V}$	20
I_{CCL}	Supply Current LOW		40	58	mA	$V_{CC} = \text{MAX.}, V_{IN} = 4.5 \text{ V}$	20

SWITCHING CHARACTERISTICS ($T_A = 25^{\circ}\text{C}$)

SYMBOL	PARAMETER	LIMITS			UNITS	TEST CONDITIONS	TEST FIGURE
		MIN.	TYP.	MAX.			
t_{PLH}	Turn Off Delay Input to Output		13	18	ns	$V_{CC} = 5.0 \text{ V}$ $C_L = 25 \text{ pF}$ $R_L = 280\Omega$	T
t_{PHL}	Turn On Delay Input to Output		10	15	ns		

NOTES:

(1) For conditions shown as MIN. or MAX., use the appropriate value specified under recommended operating conditions for the applicable device type.

(2) Typical limits are at $V_{CC} = 5.0 \text{ V}, 25^{\circ}\text{C}$.

**HEX INVERTER
(WITH OPEN-COLLECTOR OUTPUT)**

LOGIC AND CONNECTION DIAGRAM

DIP (TOP VIEW)

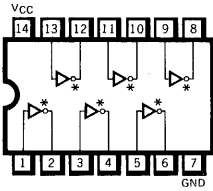

* OPEN COLLECTOR

Positive logic: $Y = \bar{A}$

FLATPAK (TOP VIEW)

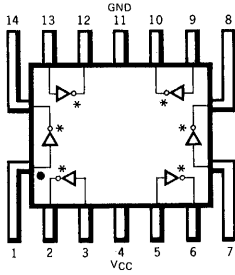

* OPEN COLLECTOR

**SCHEMATIC DIAGRAM
(EACH INVERTER)**

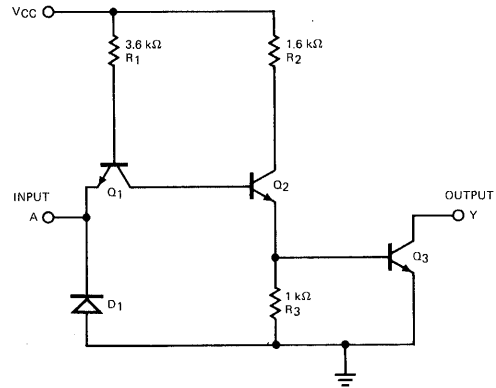

Component values shown are typical.

RECOMMENDED OPERATING CONDITIONS

PARAMETER	9N05XM/5405XM			9N05XC/7405XC			UNITS
	MIN.	TYP.	MAX.	MIN.	TYP.	MAX.	
Supply Voltage V_{CC}	4.5	5.0	5.5	4.75	5.0	5.25	Volts
Operating Free-Air Temperature Range	-55	25	125	0	25	70	°C
Normalized Fan-Out from Each Output, N			10			10	U.L.

X = package type; F for Flatpak, D for Ceramic Dip, P for Plastic Dip. See Packaging Information Section for packages available on this product.

ELECTRICAL CHARACTERISTICS OVER OPERATING TEMPERATURE RANGE (Unless Otherwise Noted)

SYMBOL	PARAMETER	LIMITS			UNITS	TEST CONDITIONS (Note 1)	TEST FIGURE
		MIN.	TYP. (Note 2)	MAX.			
V_{IH}	Input HIGH Voltage	2.0			Volts	Guaranteed Input HIGH Voltage	15
V_{IL}	Input LOW Voltage			0.8	Volts	Guaranteed Input LOW Voltage	17
I_{OH}	Output HIGH Current			0.25	mA	$V_{CC} = \text{MIN.}, V_{OH} = 5.5 \text{ V}, V_{IN} = 0.8 \text{ V}$	17
V_{OL}	Output LOW Voltage			0.4	Volts	$V_{CC} = \text{MIN.}, I_{OL} = 16 \text{ mA}, V_{IN} = 2.0 \text{ V}$ (On Level)	15
I_{IH}	Input HIGH Current			40	μA	$V_{CC} = \text{MAX.}, V_{IN} = 2.4 \text{ V}$	18
I_{IL}	Input LOW Current			1.0	mA	$V_{CC} = \text{MAX.}, V_{IN} = 5.5 \text{ V}$	
I_{CCH}	Supply Current HIGH		6	12	mA	$V_{IN} = 0 \text{ V}$	20
I_{CCL}	Supply Current LOW		18	33	mA	$V_{IN} = 5 \text{ V}$	

SWITCHING CHARACTERISTICS ($T_A = 25^\circ$)

SYMBOL	PARAMETER	LIMITS			UNITS	TEST CONDITIONS		TEST FIGURE
		MIN.	TYP.	MAX.		R_L	C_L	
t_{PLH}	Turn Off Delay Input to Output		40	55	ns	$R_L = 4 \text{ k}\Omega$	$V_{CC} = 5.0 \text{ V}$	A
t_{PHL}	Turn On Delay Input to Output		8.0	15	ns	$R_L = 400 \Omega$	$C_L = 15 \text{ pF}$	

NOTES:

- (1) For conditions shown as MIN. or MAX., use the appropriate value specified under recommended operating conditions for the applicable device type.
- (2) Typical limits are at $V_{CC} = 5.0 \text{ V}, 25^\circ\text{C}$.

**HEX INVERTER
(WITH OPEN-COLLECTOR OUTPUT)**

LOGIC AND CONNECTION DIAGRAM

DIP (TOP VIEW)

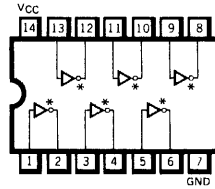

* OPEN COLLECTOR

Positive logic: $Y = \bar{A}$

SCHEMATIC DIAGRAM

(EACH INVERTER)

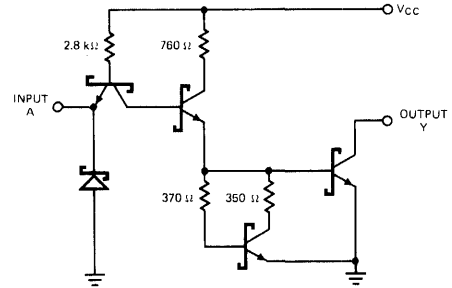

Component values shown are typical.

RECOMMENDED OPERATING CONDITIONS

PARAMETER	† 9S05XM/54S05XM † 9S05AXM			9S05XC/74S05XC 9S05AXC			UNITS
	MIN.	TYP.	MAX.	MIN.	TYP.	MAX.	
Supply Voltage V_{CC}	4.5	5.0	5.5	4.75	5.0	5.25	Volts
Operating Free-Air Temperature Range	-55	25	125	0	25	75	°C
Input Loading for Each Input			1.25			1.25	U.L.

X = package type; F for Flatpak, D for Ceramic Dip, P for Plastic Dip. See Packaging Information Section for packages available on this product.

ELECTRICAL CHARACTERISTICS OVER OPERATING TEMPERATURE RANGE (Unless Otherwise Noted)

SYMBOL	PARAMETER	LIMITS			UNITS	TEST CONDITIONS (Note 1)
		MIN.	TYP. (Note 2)	MAX.		
V_{IH}	Input HIGH Voltage	2.0			Volts	Guaranteed Input HIGH Voltage
V_{IL}	Input LOW Voltage			0.8	Volts	Guaranteed Input LOW Voltage
V_{CD}	Input Clamp Diode Voltage		-0.65	-1.2	Volts	$V_{CC} = \text{MIN.}, I_{IN} = -18\text{mA}$
I_{OH}	Output HIGH Current		0.1	250	μA	$V_{CC} = \text{MIN.}, V_{OH} = 5.5\text{V}, V_{IN} = 0.8\text{V}$
V_{OL}	Output LOW Voltage		0.35	0.5	Volts	$V_{CC} = \text{MIN.}, I_{OL} = 20\text{mA}, V_{IN} = 2.0\text{V}$
I_{IH}	Input HIGH Current		1.0	50	μA	$V_{CC} = \text{MAX.}, V_{IN} = 2.7\text{V}$
				1.0	mA	$V_{CC} = \text{MAX.}, V_{IN} = 5.5\text{V}$
I_{IL}	Input LOW Current		-1.4	-2.0	mA	$V_{CC} = \text{MAX.}, V_{IN} = 0.5\text{V}$
I_{CCH}	Supply Current HIGH		9.0	19.8	mA	$V_{CC} = \text{MAX.}, V_{IN} = 0\text{V}$
I_{CCL}	Supply Current LOW		37.8	54.0	mA	$V_{CC} = \text{MAX.}, \text{Inputs Open}$

SWITCHING CHARACTERISTICS ($T_A = 25^\circ\text{C}$)

SYMBOL	PARAMETER	LIMITS			UNITS	TEST CONDITIONS	TEST FIGURES
		MIN.	TYP.	MAX.			
t_{PLH}	Turn Off Delay Input to Output	9S05	2.0	5.0	ns	$V_{CC} = 5.0\text{V}$	EE
		9S05A	2.0	4.0			
t_{PHL}	Turn On Delay Input to Output	9S05	2.0	4.5	ns	$C_L = 15\text{pF}$	
		9S05A	1.5	3.4			

NOTES:

(1) For conditions shown as MIN. or MAX., use the appropriate value specified under recommended operating conditions for the applicable device type.

(2) Typical limits are at $V_{CC} = 5.0\text{V}, 25^\circ\text{C}$.

**HEX INVERTER BUFFER/DRIVER
(WITH OPEN-COLLECTOR HIGH-VOLTAGE OUTPUT)**

DESCRIPTION — These TTL/SSI hex inverter buffer/driver feature high voltage open collector output for interfacing with high level circuits (such as MOS), or for driving high current loads (such as lamps or relays) and are also characterized for use as inverter buffers for driving TTL inputs. For increased fan out, several inverters in a single package may be paralleled. The 9N06/5406, 7406 have minimum breakdown voltages of 30V and the 9N16/5416, 7416 have minimum breakdown voltages of 15V. The maximum sink current is 30 mA for the 9N06/5406 and 9N16/5416 and 40 mA for the 9N06/7406 and 9N16/7416.

LOGIC AND CONNECTION DIAGRAM

DIP (TOP VIEW)

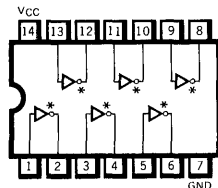

* OPEN COLLECTOR
Positive logic = $Y = \bar{A}$

FLATPAK (TOP VIEW)

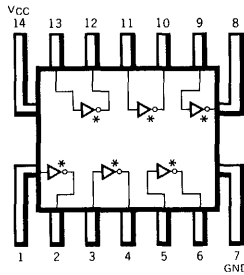

**SCHEMATIC DIAGRAM
(EACH INVERTER)**

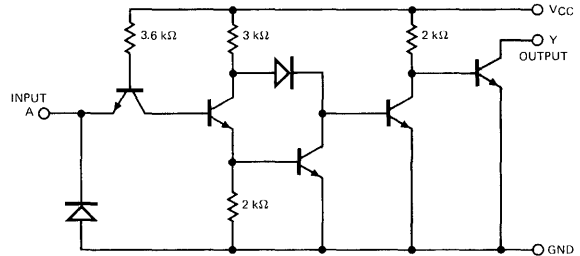

Component values shown are typical.

RECOMMENDED OPERATING CONDITIONS

PARAMETER	9N06XM/5406XM 9N16XM/5416XM			9N06XC/7406XC 9N16XC/7416XC			UNITS
	MIN.	TYP.	MAX.	MIN.	TYP.	MAX.	
Supply Voltage V_{CC}	4.5	5	5.5	4.75	5	5.25	Volts
Operating Free-Air Temperature Range	-55	25	125	0	25	70	°C
Output HIGH Voltage, V_{OH}	9N06/5406, 7406						Volts
	9N16/5416, 7416						
Output LOW Current, I_{OL}							mA

X = package type; F for Flatpak, D for Ceramic Dip, P for Plastic Dip. See Packaging Information Section for packages available on this product.

ELECTRICAL CHARACTERISTICS OVER OPERATING TEMPERATURE RANGE (Unless Otherwise Noted)

SYMBOL	PARAMETER	LIMITS			UNITS	TEST CONDITIONS (Note 1)	TEST FIGURE
		MIN.	TYP. (Note 2)	MAX.			
V_{IH}	Input HIGH Voltage	2.0			Volts	Guaranteed Input HIGH Voltage	65
V_{IL}	Input LOW Voltage			0.8	Volts	Guaranteed Input LOW Voltage	66
I_{OH}	Output HIGH Current			0.25	mA	$V_{CC} = \text{MIN.}, V_{OH} = \text{MAX.}, V_{IN} = 0.8 \text{ V}$	66
V_{OL}	Output LOW Voltage			0.7	Volts	$I_{OL} = \text{MAX.}, V_{CC} = \text{MIN.}, V_{IN} = 2.0 \text{ V}$	65
				0.4	Volts		
I_{IH}	Input HIGH Current			40	μA	$V_{CC} = \text{MAX.}, V_{IN} = 2.4 \text{ V}$	Each Input 67
				1.0	mA	$V_{CC} = \text{MAX.}, V_{IN} = 5.5 \text{ V}$	
I_{IL}	Input LOW Current			-1.6	mA	$V_{CC} = \text{MAX.}, V_{IN} = 0.4 \text{ V}$, Each Input	68
I_{CCH}	Supply Current HIGH		30	42	mA	$V_{CC} = \text{MAX.}, V_{IN} = 0 \text{ V}$	69
I_{CCL}	Supply Current LOW		27	38	mA	$V_{CC} = \text{MAX.}, V_{IN} = 5.0 \text{ V}$	69

SWITCHING CHARACTERISTICS ($T_A = 25^\circ\text{C}$)

SYMBOL	PARAMETER	LIMITS			UNITS	TEST CONDITIONS	TEST FIGURE
		MIN.	TYP.	MAX.			
t_{PLH}	Turn Off Delay Input to Output		10	15 *	ns	$V_{CC} = 5.0 \text{ V}$ $C_L = 15 \text{ pF}$ $R_L = 110\Omega$	J
t_{PHL}	Turn On Delay Input to Output		15	23	ns		

NOTES:

(1) For conditions shown as MIN. or MAX., use the appropriate value specified under recommended operating conditions for the applicable device type.

(2) Typical limits are at $V_{CC} = 5.0 \text{ V}$, 25°C .

* Max. 17 ns at 125°C

HEX BUFFER/DRIVER
(WITH OPEN-COLLECTOR HIGH-VOLTAGE OUTPUT)

DESCRIPTION — These TTL/SSI hex buffer/driver feature high voltage open collector output for interfacing with high level circuits (such as MOS), or for driving high current loads (such as lamps or relays) and are also characterized for use as buffers for driving TTL inputs. For increased fan out, several buffers in a single package may be paralleled. The 9N07/5407, 7404 have minimum breakdown voltages of 30V and the 9N17/5417, 7417 have minimum breakdown voltages of 15V. The maximum sink current is 30 mA for the 9N07/5407 and 40 mA for the 9N07/7407 and 9N17/7417.

LOGIC AND CONNECTION DIAGRAM

DIP (TOP VIEW)

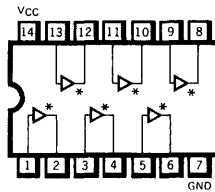

* OPEN COLLECTOR

Positive logic: $Y = A$

FLATPAK (TOP VIEW)

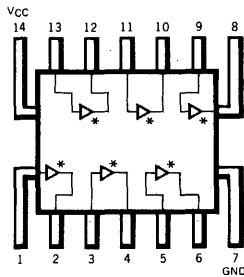

SCHEMATIC DIAGRAM
(EACH BUFFER/DRIVER)

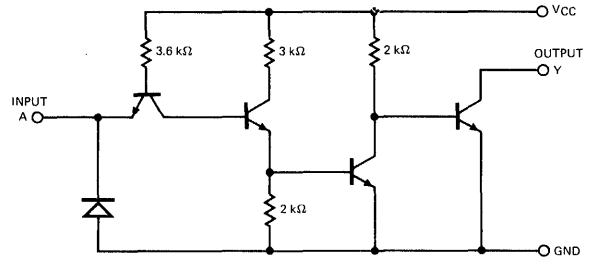

Component values shown are typical.

RECOMMENDED OPERATING CONDITIONS

PARAMETER	9N07XM/5407XM 9N17XM/5417XM			9N07XC/7407XC 9N17XC/7417XC			UNITS
	MIN.	TYP.	MAX.	MIN.	TYP.	MAX.	
Supply Voltage V_{CC}	4.5	5	5.5	4.75	5	5.25	Volts
Operating Free-Air Temperature Range	-55	25	125	0	25	70	°C
Output HIGH Level Voltage, V_{OH}	9N07/5407, 7407		30			30	Volts
	9N17/5417, 7417		15			15	
Output LOW Level Current, I_{OL}			30			40	mA

X = package type; F for Flatpak, D for Ceramic Dip, P for Plastic Dip. See Packaging Information Section for packages available on this product.

ELECTRICAL CHARACTERISTICS OVER OPERATING TEMPERATURE RANGE (Unless Otherwise Noted)

SYMBOL	PARAMETER	LIMITS			UNITS	TEST CONDITIONS (Note 1)	TEST FIGURE
		MIN.	TYP. (Note 2)	MAX.			
V_{IH}	Input HIGH Voltage	2.0			Volts	Guaranteed Input HIGH Voltage	70
V_{IL}	Input LOW Voltage			0.8	Volts	Guaranteed Input LOW Voltage	71
I_{OH}	Output HIGH Current			0.25	mA	$V_{CC} = \text{MIN.}, V_{OH} = \text{MAX.}, V_{IN} = 2.0 \text{ V}$	70
V_{OL}	Output LOW Voltage			0.7	Volts	$I_{OL} = \text{MAX.}, V_{CC} = \text{MIN.}, V_{IN} = 0.8 \text{ V}$	71
				0.4	Volts		
I_{IH}	Input HIGH Current			40	μA	$V_{CC} = \text{MAX.}, V_{IN} = 2.4 \text{ V}$	Each Input
				1.0	mA		
I_{IL}	Input LOW Current			-1.6	mA	$V_{CC} = \text{MAX.}, V_{IN} = 0.4 \text{ V}$	Each Input
I_{CCH}	Supply Current HIGH		29	41	mA	$V_{CC} = \text{MAX.}, V_{IN} = 5 \text{ V}$	74
I_{CCL}	Supply Current LOW		21	30	mA	$V_{CC} = \text{MAX.}, V_{IN} = 0 \text{ V}$	74

SWITCHING CHARACTERISTICS ($T_A = 25^\circ\text{C}$)

SYMBOL	PARAMETER	LIMITS			UNITS	TEST CONDITIONS	TEST FIGURE
		MIN.	TYP.	MAX.			
t_{PLH}	Turn Off Delay Input to Output		6.0	10	ns	$V_{CC} = 5.0 \text{ V}$ $C_L = 15 \text{ pF}$ $R_L = 110\Omega$	K
t_{PHL}	Turn On Delay Input to Output		20	30	ns		

NOTES:

- (1) For conditions shown as MIN. or MAX., use the appropriate value specified under recommended operating conditions for the applicable device type.
- (2) Typical limits are at $V_{CC} = 5.0 \text{ V}, 25^\circ\text{C}$.

FAIRCHILD HIGH SPEED TTL/SSI • 9H08/54H08, 74H08

QUAD 2-INPUT AND GATE

LOGIC AND CONNECTION DIAGRAM

DIP (TOP VIEW)

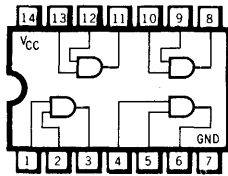

Positive logic: $Y = AB$

FLATPAK (TOP VIEW)

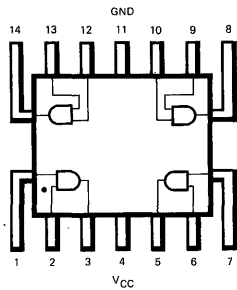

SCHEMATIC DIAGRAM (EACH GATE)

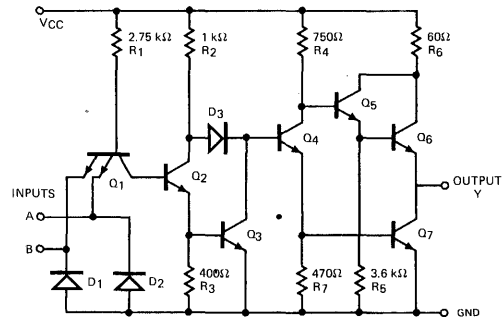

Component values shown are typical.

RECOMMENDED OPERATING CONDITIONS

PARAMETER	9H08XM/5408XM			9H08XC/74H08XC			UNITS
	MIN.	TYP.	MAX.	MIN.	TYP.	MAX.	
Supply Voltage V_{CC}	4.5	5.0	5.5	4.75	5.0	5.25	Volts
Operating Free-Air Temperature Range	-55	25	125	0	25	70	$^{\circ}C$
Input Loading for Each Input			1.25			1.25	U.L.

X = package type; F for Flatpak, D for Ceramic Dip, P for Plastic Dip. See Packaging Information Section for packages available on this product.

ELECTRICAL CHARACTERISTICS OVER OPERATING TEMPERATURE RANGE (Unless Otherwise Noted)

SYMBOL	PARAMETER	LIMITS			UNITS	TEST CONDITIONS (Note 1)	TEST FIGURE
		MIN.	TYP. (Note 2)	MAX.			
V_{IH}	Input HIGH Voltage	2.0			Volts	Guaranteed Input HIGH Voltage	75
V_{IL}	Input LOW Voltage			0.8	Volts	Guaranteed Input LOW Voltage	77
V_{OH}	Output HIGH Voltage	2.4			Volts	$V_{CC} = \text{MIN.}, I_{OH} = -0.5 \text{ mA}, V_{IN} = 2.0 \text{ V}$	75
V_{OL}	Output LOW Voltage			0.4	Volts	$V_{CC} = \text{MIN.}, I_{OL} = 20 \text{ mA}, V_{IN} = 0.8 \text{ V}$	77
I_{IH}	Input HIGH Current			50	μA	$V_{CC} = \text{MAX.}, V_{IN} = 2.4 \text{ V}$	Each Input 78
				1.0	mA	$V_{CC} = \text{MAX.}, V_{IN} = 5.5 \text{ V}$	
I_{IL}	Input LOW Current			-2.0	mA	$V_{CC} = \text{MAX.}, V_{IN} = 0.4 \text{ V}$, Each Input	79
I_{OS}	Output Short Circuit Current (Note 3)	-40		-100	mA	$V_{CC} = \text{MAX.}, V_{IN} = 4.5 \text{ V}$	80
I_{CCH}	Supply Current HIGH		24	40	mA	$V_{CC} = \text{MAX.}, V_{IN} = 4.5 \text{ V}$	81
I_{CCL}	Supply Current LOW		40	64	mA	$V_{CC} = \text{MAX.}, V_{IN} = 0 \text{ V}$	81

SWITCHING CHARACTERISTICS ($T_A = 25^{\circ}C$)

SYMBOL	PARAMETER	LIMITS			UNITS	TEST CONDITIONS	TEST FIGURE
		MIN.	TYP.	MAX.			
t_{PLH}	Turn Off Delay Input to Output		7.6	12	ns	$V_{CC} = 5.0 \text{ V}$ $C_L = 25 \text{ pF}$ $R_L = 280 \Omega$	T
t_{PHL}	Turn On Delay Input to Output		8.8	12	ns		

NOTES:

- (1) For conditions shown as MIN. or MAX., use the appropriate value specified under recommended operating conditions for the applicable device type.
- (2) Typical limits are at $V_{CC} = 5.0 \text{ V}, 25^{\circ}C$.
- (3) Not more than one output should be shorted at a time, and duration of short-circuit test should not exceed 1 second.

QUAD 2-INPUT AND GATE

LOGIC AND CONNECTION DIAGRAM

DIP (TOP VIEW)

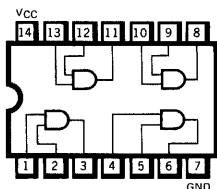

Positive logic: $Y = AB$

FLATPAK (TOP VIEW)

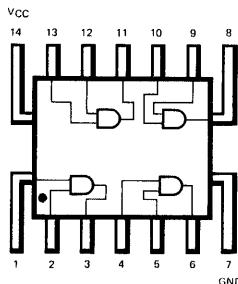

SCHEMATIC DIAGRAM (EACH GATE)

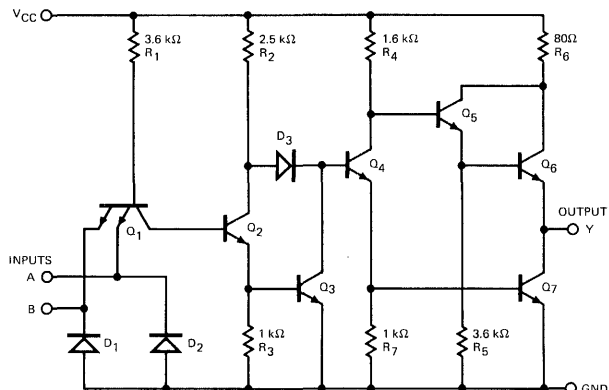

Component values shown are typical.

RECOMMENDED OPERATING CONDITIONS

PARAMETER	9N08XM/5408XM			9N08XC/7408XC			UNITS
	MIN.	TYP.	MAX.	MIN.	TYP.	MAX.	
Supply Voltage V_{CC}	4.5	5.0	5.5	4.75	5.0	5.25	Volts
Operating Free-Air Temperature Range	-55	25	125	0	25	70	$^{\circ}C$
Normalized Fan Out from Each Output, N			10			10	U.L.

X = package type; F for Flatpak, D for Ceramic Dip, P for Plastic Dip. See Packaging Information Section for packages available on this product.

ELECTRICAL CHARACTERISTICS OVER OPERATING TEMPERATURE RANGE (Unless Otherwise Noted)

SYMBOL	PARAMETER	LIMITS			UNITS	TEST CONDITIONS (Note 1)	TEST FIGURE
		MIN.	TYP. (Note 2)	MAX.			
V_{IH}	Input HIGH Voltage	2.0			Volts	Guaranteed Input HIGH Voltage	75
V_{IL}	Input LOW Voltage			0.8	Volts	Guaranteed Input LOW Voltage	77
V_{OH}	Output HIGH Voltage	2.4			Volts	$V_{CC} = \text{MIN.}, I_{OH} = -0.8 \text{ mA}, V_{IH} = 2.0 \text{ V}$	75
V_{OL}	Output LOW Voltage			0.4	Volts	$V_{CC} = \text{MIN.}, I_{OL} = 16 \text{ mA}, V_{IL} = 0.8 \text{ V}$	77
I_{IH}	Input HIGH Current			40	μA	$V_{CC} = \text{MAX.}, V_{IN} = 2.4 \text{ V}$	Each Input 78
				1.0	mA	$V_{CC} = \text{MAX.}, V_{IN} = 5.5 \text{ V}$	
I_{IL}	Input LOW Current			-1.6	mA	$V_{CC} = \text{MAX.}, V_{IN} = 0.4 \text{ V}$, Each Input	79
I_{OS}	Output Short Circuit Current (Note 3)	-40		-100	mA	$V_{CC} = \text{MAX.}$	80
I_{CCH}	Supply Current HIGH			20	mA	$V_{CC} = \text{MAX.}, V_{IN} = 5 \text{ V}$	81
I_{CCL}	Supply Current LOW			32	mA	$V_{CC} = \text{MAX.}, V_{IN} = 0 \text{ V}$	81

SWITCHING CHARACTERISTICS ($T_A = 25^{\circ}C$)

SYMBOL	PARAMETER	LIMITS			UNITS	TEST CONDITIONS	TEST FIGURE
		MIN.	TYP.	MAX.			
t_{PLH}	Turn Off Delay Input to Output		17.5	40	ns	$V_{CC} = 5.0 \text{ V}$ $C_L = 15 \text{ pF}$ $R_L = 400\Omega$	L
t_{PHL}	Turn On Delay Input to Output		12	25	ns		

NOTES:

- (1) For conditions shown as MIN. or MAX., use the appropriate value specified under recommended operating conditions for the applicable device type.
- (2) Typical limits are at $V_{CC} = 5.0 \text{ V}, 25^{\circ}C$
- (3) Not more than one output should be shorted at a time.

QUAD 2-INPUT AND GATE (WITH OPEN-COLLECTOR OUTPUT)

LOGIC AND CONNECTION DIAGRAM

DIP (TOP VIEW)

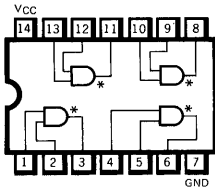

*OPEN COLLECTOR

Positive logic: $Y = AB$

FLATPAK (TOP VIEW)

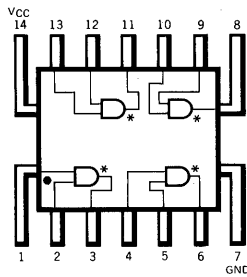

*OPEN COLLECTOR

SCHEMATIC DIAGRAM (EACH GATE)

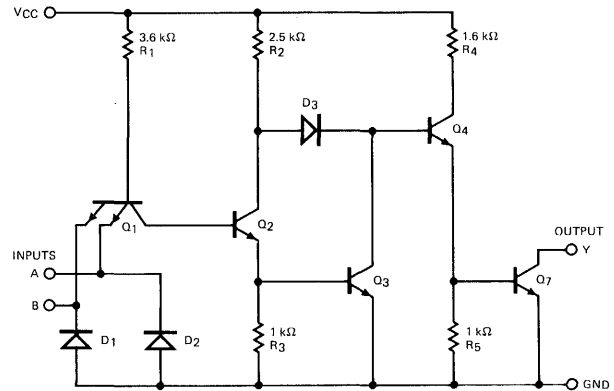

Component values shown are typical.

RECOMMENDED OPERATING CONDITIONS

PARAMETER	9N09XM/5409XM			9N09XC/7409XC			UNITS
	MIN.	TYP.	MAX.	MIN.	TYP.	MAX.	
Supply Voltage V_{CC}	4.5	5.0	5.5	4.75	5.0	5.25	Volts
Operating Free-Air Temperature Range	-55	25	125	0	25	70	$^{\circ}C$
Normalized Fan-Out from Each Output, N			10			10	U.L.

X = package type; F for Flatpak, D for Ceramic Dip, P for Plastic Dip. See Packaging Information Section for packages available on this product.

ELECTRICAL CHARACTERISTICS OVER OPERATING TEMPERATURE RANGE (Unless Otherwise Noted)

SYMBOL	PARAMETER	LIMITS			UNITS	TEST CONDITIONS (Note 1)	TEST FIGURE
		MIN.	TYP. (Note 2)	MAX.			
V_{IH}	Input HIGH Voltage	2.0			Volts	Guaranteed Input HIGH Voltage	76
V_{IL}	Input LOW Voltage			0.8	Volts	Guaranteed Input LOW Voltage	77
I_{OH}	Output HIGH Current			0.25	mA	$V_{CC} = \text{MIN.}, V_{IH} = 2.0 \text{ V}, V_{OH} = 5.5 \text{ V}$	76
V_{OL}	Output LOW Voltage			0.4	Volts	$V_{CC} = \text{MIN.}, I_{OL} = 16 \text{ mA}, V_{IL} = 0.8 \text{ V}$	77
I_{IH}	Input HIGH Current			40	μA	$V_{CC} = \text{MAX.}, V_{IN} = 2.4 \text{ V}$	Each Input 78
				1.0	mA	$V_{CC} = \text{MAX.}, V_{IN} = 5.5 \text{ V}$	
I_{IL}	Input LOW Current			-1.6	mA	$V_{CC} = \text{MAX.}, V_{IN} = 0.4 \text{ V}$	Each Input 79
I_{CCH}	Supply Current HIGH		11	21	mA	$V_{CC} = \text{MAX.}, V_{IN} = 5.0 \text{ V}$	81
I_{CCL}	Supply Current LOW		20	33	mA	$V_{CC} = \text{MAX.}, V_{IN} = 0 \text{ V}$	81

SWITCHING CHARACTERISTICS ($T_A = 25^{\circ}C$)

SYMBOL	PARAMETER	LIMITS			UNITS	TEST CONDITIONS	TEST FIGURE
		MIN.	TYP.	MAX.			
t_{PLH}	Turn Off Delay Input to Output		21	32	ns	$V_{CC} = 5.0 \text{ V}$ $C_L = 15 \text{ pF}$ $R_L = 400\Omega$	L
t_{PHL}	Turn On Delay Input to Output		16	24	ns		

NOTES:

(1) For conditions shown as MIN. or MAX., use the appropriate value specified under recommended operating conditions for the applicable device type.

(2) Typical limits are at $V_{CC} = 5.0 \text{ V}, 25^{\circ}C$.

TRIPLE 3-INPUT NAND GATE

LOGIC AND CONNECTION DIAGRAM

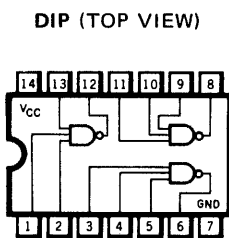

Positive logic: $Y = \overline{ABC}$

FLATPAK (TOP VIEW)

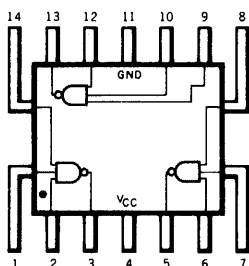

SCHEMATIC DIAGRAM (EACH GATE)

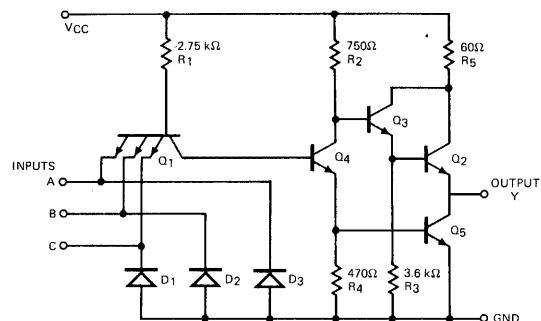

Component values shown are typical.

RECOMMENDED OPERATING CONDITIONS

PARAMETER	9H10XM/54H10XM			9H10XC/74H10XC			UNITS
	MIN.	TYP.	MAX.	MIN.	TYP.	MAX.	
Supply Voltage V_{CC}	4.5	5.0	5.5	4.75	5.0	5.25	Volts
Operating Free-Air Temperature Range	-55	25	125	0	25	70	$^{\circ}C$
Input Loading for Each Input			1.25			1.25	U.L.

X = package type; F for Flatpak, D for Ceramic Dip, P for Plastic Dip. See Packaging Information Section for packages available on this product.

ELECTRICAL CHARACTERISTICS OVER OPERATING TEMPERATURE RANGE (Unless Otherwise Noted)

SYMBOL	PARAMETER	LIMITS			UNITS	TEST CONDITIONS (Note 1)	TEST FIGURE
		MIN.	TYP. (Note 2)	MAX.			
V_{IH}	Input HIGH Voltage	2.0			Volts	Guaranteed Input HIGH Voltage	1
V_{IL}	Input LOW Voltage			0.8	Volts	Guaranteed Input LOW Voltage	2
V_{OH}	Output HIGH Voltage	2.4			Volts	$V_{CC} = \text{MIN.}, I_{OH} = -0.5 \text{ mA}, V_{IN} = 0.8 \text{ V}$	2
V_{OL}	Output LOW Voltage			0.4	Volts	$V_{CC} = \text{MIN.}, I_{OL} = 20 \text{ mA}, V_{IN} = 2.0 \text{ V}$	1
I_{IH}	Input HIGH Current			50	μA	$V_{CC} = \text{MAX.}, V_{IN} = 2.4 \text{ V}$	Each Input
				1.0	mA	$V_{CC} = \text{MAX.}, V_{IN} = 5.5 \text{ V}$	
I_{IL}	Input LOW Current			-2.0	mA	$V_{CC} = \text{MAX.}, V_{IN} = 0.4 \text{ V}$, Each Input	3
I_{OS}	Output Short Circuit Current (Note 3)	-40		-100	mA	$V_{CC} = \text{MAX.}$	5
I_{CCH}	Supply Current HIGH		7.5	12.6	mA	$V_{CC} = \text{MAX.}, V_{IN} = 0 \text{ V}$	6
I_{CCL}	Supply Current LOW		19.5	30	mA	$V_{CC} = \text{MAX.}, V_{IN} = 4.5 \text{ V}$	6

SWITCHING CHARACTERISTICS ($T_A = 25^{\circ}C$)

SYMBOL	PARAMETER	LIMITS			UNITS	TEST CONDITIONS	TEST FIGURE
		MIN.	TYP.	MAX.			
t_{PLH}	Turn Off Delay Input to Output		5.9	10	ns	$V_{CC} = 5.0 \text{ V}$ $C_L = 25 \text{ pF}$ $R_L = 280 \Omega$	T
t_{PHL}	Turn On Delay Input to Output		6.3	10	ns		

NOTES:

- (1) For conditions shown as MIN. or MAX., use the appropriate value specified under recommended operating conditions for the applicable device type.
- (2) Typical limits are at $V_{CC} = 5.0 \text{ V}, 25^{\circ}C$.
- (3) Not more than one output should be shorted at a time, and duration of short-circuit test should not exceed 1 second.

TRIPLE 3-INPUT NAND GATE

LOGIC AND CONNECTION DIAGRAM

DIP (TOP VIEW)

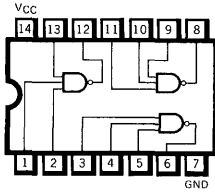

Positive logic: $Y = \overline{ABC}$

FLATPAK (TOP VIEW)

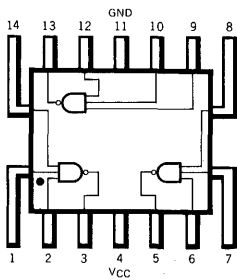

SCHEMATIC DIAGRAM (EACH GATE)

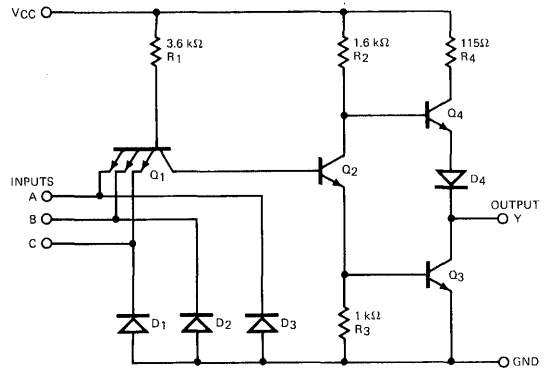

Component values shown are typical.

RECOMMENDED OPERATING CONDITIONS

PARAMETER	9N10XM/5410XM			9N10XC/7410XC			UNITS
	MIN.	TYP.	MAX.	MIN.	TYP.	MAX.	
Supply Voltage V_{CC}	4.5	5.0	5.5	4.75	5.0	5.25	Volts
Operating Free-Air Temperature Range	-55	25	125	0	25	70	°C
Normalized Fan-Out from Each Output, N			10			10	U.L.

X = package type; F for Flatpak, D for Ceramic Dip, P for Plastic Dip. See Packaging Information Section for packages available on this product.

ELECTRICAL CHARACTERISTICS OVER OPERATING TEMPERATURE RANGE (Unless Otherwise Noted)

SYMBOL	PARAMETER	LIMITS			UNITS	TEST CONDITIONS (Note 1)	TEST FIGURE
		MIN.	TYP. (Note 2)	MAX.			
V_{IH}	Input HIGH Voltage	2.0			Volts	Guaranteed Input HIGH Voltage	1
V_{IL}	Input LOW Voltage			0.8	Volts	Guaranteed Input LOW Voltage	2
V_{OH}	Output HIGH Voltage	2.4	3.3		Volts	$V_{CC} = \text{MIN.}$, $I_{OH} = -0.4 \text{ mA}$, $V_{IN} = 0.8 \text{ V}$	2
V_{OL}	Output LOW Voltage		0.22	0.4	Volts	$V_{CC} = \text{MIN.}$, $I_{OL} = 16 \text{ mA}$, $V_{IN} = 2.0 \text{ V}$	1
I_{IH}	Input HIGH Current			40	μA	$V_{CC} = \text{MAX.}$, $V_{IN} = 2.4 \text{ V}$	Each Input
				1.0	mA	$V_{CC} = \text{MAX.}$, $V_{IN} = 5.5 \text{ V}$	
I_{IL}	Input LOW Current			-1.6	mA	$V_{CC} = \text{MAX.}$, $V_{IN} = 0.4 \text{ V}$, Each Input	3
I_{OS}	Output Short Circuit Current (Note 3)	-20		-55	mA	9N10/5410	$V_{CC} = \text{MAX.}$
		-18		-55	mA	9N10/7410	
I_{CCH}	Supply Current HIGH		3.0	6.0	mA	$V_{CC} = \text{MAX.}$, $V_{IN} = 0 \text{ V}$	6
I_{CCL}	Supply Current LOW		9.0	16.5	mA	$V_{CC} = \text{MAX.}$, $V_{IN} = 5.0 \text{ V}$	6

SWITCHING CHARACTERISTICS ($T_A = 25^\circ\text{C}$)

SYMBOL	PARAMETER	LIMITS			UNITS	TEST CONDITIONS	TEST FIGURE
		MIN.	TYP.	MAX.			
t_{PLH}	Turn Off Delay Input to Output		11	22	ns	$V_{CC} = 5.0 \text{ V}$ $C_L = 15 \text{ pF}$ $R_L = 400\Omega$	A
t_{PHL}	Turn On Delay Input to Output		7.0	15	ns		

NOTES:

- (1) For conditions shown as MIN. or MAX., use the appropriate value specified under recommended operating conditions for the applicable device type.
- (2) Typical limits are at $V_{CC} = 5.0 \text{ V}$, 25°C .
- (3) Not more than one output should be shorted at a time.

FAIRCHILD HIGH SPEED TTL/SSI • 9H11/54H11, 74H11

TRIPLE 3-INPUT AND GATE

LOGIC AND CONNECTION DIAGRAM

DIP (TOP VIEW)

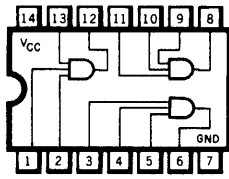

Positive logic: $Y = ABC$

FLATPAK (TOP VIEW)

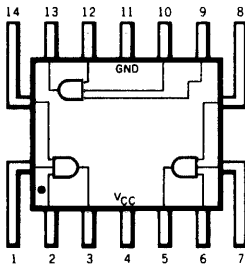

SCHEMATIC DIAGRAM (EACH GATE)

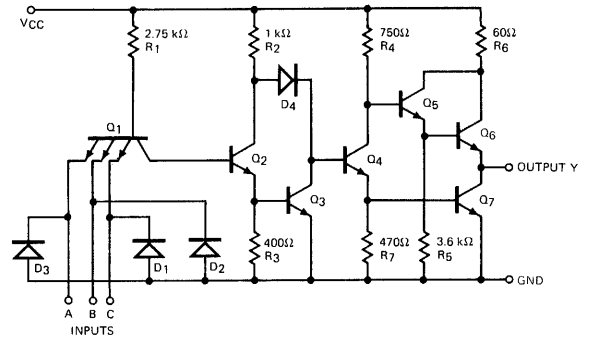

Component values shown are typical.

RECOMMENDED OPERATING CONDITIONS

PARAMETER	9H11XM/54H11XM			9H11XC/74H11XC			UNITS
	MIN.	TYP.	MAX.	MIN.	TYP.	MAX.	
Supply Voltage V_{CC}	4.5	5.0	5.5	4.75	5.0	5.25	Volts
Operating Free-Air Temperature Range	-55	25	125	0	25	70	°C
Input Loading for Each Input			1.25			1.25	U.L.

X = package type; F for Flatpak, D for Ceramic Dip, P for Plastic Dip. See Packaging Information Section for packages available on this product.

ELECTRICAL CHARACTERISTICS OVER OPERATING TEMPERATURE RANGE (Unless Otherwise Noted)

SYMBOL	PARAMETER	LIMITS			UNITS	TEST CONDITIONS (Note 1)	TEST FIGURE
		MIN.	TYP. (Note 2)	MAX.			
V_{IH}	Input HIGH Voltage	2.0			Volts	Guaranteed Input HIGH Voltage	75
V_{IL}	Input LOW Voltage			0.8	Volts	Guaranteed Input LOW Voltage	77
V_{OH}	Output HIGH Voltage	2.4			Volts	$V_{CC} = \text{MIN.}, I_{OH} = -0.5 \text{ mA}, V_{IN} = 2.0 \text{ V}$	75
V_{OL}	Output LOW Voltage			0.4	Volts	$V_{CC} = \text{MIN.}, I_{OL} = 20 \text{ mA}, V_{IN} = 0.8 \text{ V}$	77
I_{IH}	Input HIGH Current			50	μA	$V_{CC} = \text{MAX.}, V_{IN} = 2.4 \text{ V}$	Each Input 78
				1.0	mA	$V_{CC} = \text{MAX.}, V_{IN} = 5.5 \text{ V}$	
I_{IL}	Input LOW Current			-2.0	mA	$V_{CC} = \text{MAX.}, V_{IN} = 0.4 \text{ V}$, Each Input	79
I_{OS}	Output Short Circuit Current (Note 3)	-40		-100	mA	$V_{CC} = \text{MAX.}, V_{IN} = 4.5 \text{ V}$	80
I_{CCH}	Supply Current HIGH		18	30	mA	$V_{CC} = \text{MAX.}, V_{IN} = 4.5 \text{ V}$	81
I_{CCL}	Supply Current LOW		30	48	mA	$V_{CC} = \text{MAX.}, V_{IN} = 0 \text{ V}$	81

SWITCHING CHARACTERISTICS ($T_A = 25^\circ\text{C}$)

SYMBOL	PARAMETER	LIMITS			UNITS	TEST CONDITIONS	TEST FIGURE
		MIN.	TYP.	MAX.			
tPLH	Turn Off Delay Input to Output		7.6	12	ns	$V_{CC} = 5.0 \text{ V}$ $C_L = 25 \text{ pF}$ $R_L = 280 \Omega$	T
tPHL	Turn On Delay Input to Output		8.8	12	ns		

NOTES:

(1) For conditions shown as MIN. or MAX., use the appropriate value specified under recommended operating conditions for the applicable device type.

(2) Typical limits are at $V_{CC} = 5.0 \text{ V}$, 25°C .

(3) Not more than one output should be shorted at a time, and duration of short-circuit test should not exceed 1 second.

TRIPLE 3-INPUT AND GATE

LOGIC AND CONNECTION DIAGRAM

DIP (TOP VIEW)

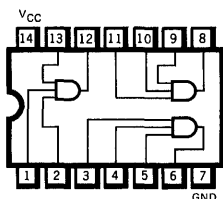

FLATPAK (TOP VIEW)

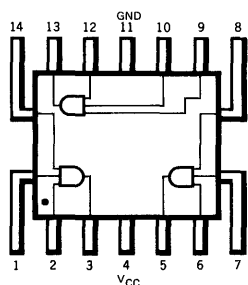

Positive logic: $Y = ABC$

SCHEMATIC DIAGRAM (EACH GATE)

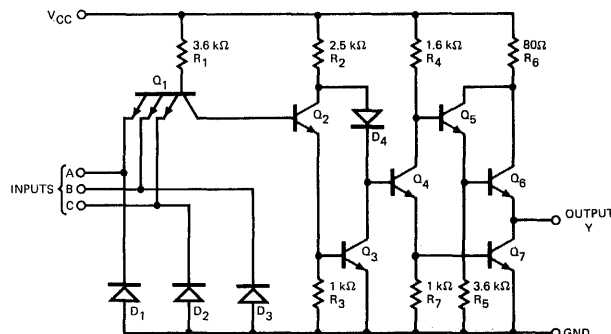

Component values shown are typical.

RECOMMENDED OPERATING CONDITIONS

PARAMETER	9N11XM/5411XM			9N11XC/7411XC			UNITS
	MIN.	TYP.	MAX.	MIN.	TYP.	MAX.	
Supply Voltage V_{CC}	4.5	5.0	5.5	4.75	5.0	5.25	Volts
Operating Free-Air Temperature Range	-55	25	125	0	25	70	°C
Normalized Fan Out from Each Output, N			10			10	U.L.

X = package type; F for Flatpak, D for Ceramic Dip, P for Plastic Dip. See Packaging Information Section for packages available on this product.

ELECTRICAL CHARACTERISTICS OVER OPERATING TEMPERATURE RANGE (Unless Otherwise Noted)

SYMBOL	PARAMETER	LIMITS			UNITS	TEST CONDITIONS (Note 1)
		MIN.	TYP. (Note 2)	MAX.		
V_{IH}	Input HIGH Voltage	2.0			Volts	Guaranteed Input HIGH Voltage
V_{IL}	Input LOW Voltage			0.8	Volts	Guaranteed Input LOW Voltage
V_{OH}	Output HIGH Voltage	2.4			Volts	$V_{CC} = \text{MIN.}, I_{OH} = -0.4 \text{ mA}, V_{IN} = 2 \text{ V}$
V_{OL}	Output LOW Voltage			0.4	Volts	$V_{CC} = \text{MIN.}, I_{OL} = 16 \text{ mA}, V_{IN} = 0.8 \text{ V}$
I_{IH}	Input HIGH Current			40	μA	$V_{CC} = \text{MAX.}, V_{IN} = 2.4 \text{ V}$
				1.0	mA	$V_{CC} = \text{MAX.}, V_{IN} = 5.5 \text{ V}$
I_{IL}	Input LOW Current			-1.6	mA	$V_{CC} = \text{MAX.}, V_{IN} = 0.4 \text{ V}$, Each Input
I_{OS}	Output Short Circuit Current (Note 3)	-40		-100	mA	$V_{CC} = \text{MAX.}, V_{IN} = 4.5 \text{ V}$
I_{CCH}	Supply Current HIGH		10	15	mA	$V_{CC} = \text{MAX.}, V_{IN} = 0 \text{ V}$
I_{CCL}	Supply Current LOW		6.0	24	mA	$V_{CC} = \text{MAX.}, V_{IN} = 5.0 \text{ V}$

SWITCHING CHARACTERISTICS ($T_A = 25^\circ\text{C}$)

SYMBOL	PARAMETER	LIMITS			UNITS	TEST CONDITIONS
		MIN.	TYP.	MAX.		
t_{PLH}	Turn Off Delay Input to Output		18	40	ns	$V_{CC} = 5.0 \text{ V}$ $C_L = 15 \text{ pF}$ $R_L = 400\Omega$
t_{PHL}	Turn On Delay Input to Output		14	25	ns	

NOTES:

- (1) For conditions shown as MIN. or MAX., use the appropriate value specified under recommended operating conditions for the applicable device type.
- (2) Typical limits are at $V_{CC} = 5.0 \text{ V}, 25^\circ\text{C}$.
- (3) Not more than one output should be shorted at a time.

TRIPLE 3-INPUT NAND GATE (WITH OPEN-COLLECTOR OUTPUT)

LOGIC AND CONNECTION DIAGRAM

DIP (TOP VIEW)

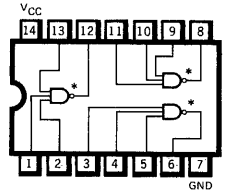

* Open collector
Positive logic: $Y = \overline{ABC}$

FLATPAK (TOP VIEW)

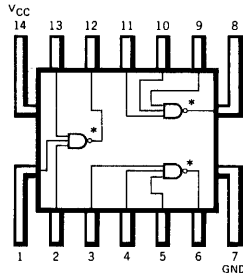

SCHEMATIC DIAGRAM (EACH GATE)

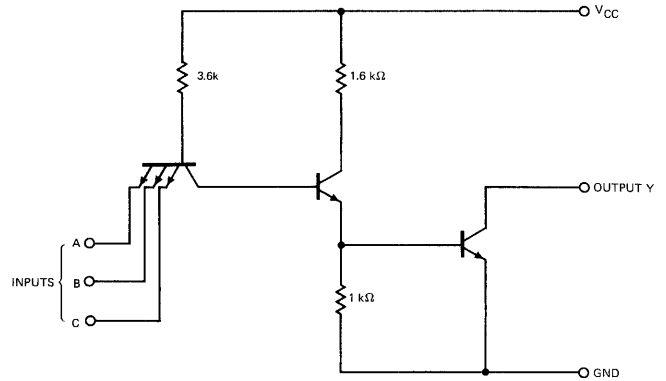

Component values shown are typical.

RECOMMENDED OPERATING CONDITIONS

PARAMETER	9N12XM/5412XM			9N12XC/7412XC			UNITS
	MIN.	TYP.	MAX.	MIN.	TYP.	MAX.	
Supply Voltage V_{CC}	4.5	5.0	5.5	4.75	5.0	5.25	Volts
Operating Free-Air Temperature Range	-55	25	125	0	25	70	$^{\circ}C$
Normalized Fan Out from Each Output, N			10			10	U.L.

X = package type; F for Flatpak, D for Ceramic Dip, P for Plastic Dip. See Packaging Information Section for packages available on this product.

ELECTRICAL CHARACTERISTICS OVER OPERATING TEMPERATURE RANGE (Unless Otherwise Noted)

SYMBOL	PARAMETER	LIMITS			UNITS	TEST CONDITIONS (Note 1)	TEST FIGURE	
		MIN.	TYP. (Note 2)	MAX.				
V_{IH}	Input HIGH Voltage	2.0			Volts	Guaranteed Input HIGH Voltage	1	
V_{IL}	Input LOW Voltage			0.8	Volts	Guaranteed Input LOW Voltage	7	
I_{OH}	Output HIGH Current			0.25	mA	$V_{CC} = \text{MIN.}, V_{OH} = 5.5 \text{ V}, V_{IL} = 0.8 \text{ V}$	7	
V_{OL}	Output LOW Voltage			0.4	Volts	$V_{CC} = \text{MIN.}, I_{OL} = 16 \text{ mA}, V_{IN} = 2.0 \text{ V (On Level)}$	1	
I_{IH}	Input HIGH Current			40	μA	$V_{CC} = \text{MAX.}, V_{IN} = 2.4 \text{ V}$	Each Input	4
				1.0	mA	$V_{CC} = \text{MAX.}, V_{IN} = 5.5 \text{ V}$		
I_{IL}	Input LOW Current			-1.6	mA	$V_{CC} = \text{MAX.}, V_{IN} = 0.4 \text{ V}, \text{ Each Input}$	3	
I_{CCH}	Supply Current HIGH		3.0	6.0	mA	$V_{CC} = \text{MAX.}, V_{IN} = 0 \text{ V}$	6	
I_{CCL}	Supply Current LOW		9.0	16.5	mA	$V_{CC} = \text{MAX.}, V_{IN} = 5.0 \text{ V}$	6	

SWITCHING CHARACTERISTICS ($T_A = 25^{\circ}C$)

SYMBOL	PARAMETER	LIMITS			UNITS	TEST CONDITIONS	TEST FIGURE
		MIN.	TYP.	MAX.			
t_{PLH}	Turn Off Delay Input to Output		35	45	ns	$R_L = 4 \text{ k}\Omega$	A
t_{PHL}	Turn On Delay Input to Output		8.0	15	ns	$R_L = 400\Omega$	

NOTES:

- (1) For conditions shown as MIN. or MAX., use the appropriate value specified under recommended operating conditions for the applicable device type.
- (2) Typical limits are at $V_{CC} = 5.0 \text{ V}, 25^{\circ}C$.

DUAL NAND SCHMITT TRIGGER

DESCRIPTION — The 9N13/5413, 7413 are dual Schmitt triggers functions, compatible with standard TTL output logic levels. Each function is essentially a 4-input NAND gate with different input threshold levels for positive and negative going signals. Typically the hysteresis, the difference between the two threshold levels, is 800 mV.

On-chip temperature compensation ensures excellent stability of the hysteresis over a wide temperature range. Typically the hysteresis changes by 3% over the range of -55°C to +125°C, the upper threshold changes by 1% over the same range. The 9N13/5413, 7413 can be triggered from slow input ramps and straight dc levels.

LOGIC AND CONNECTION DIAGRAM

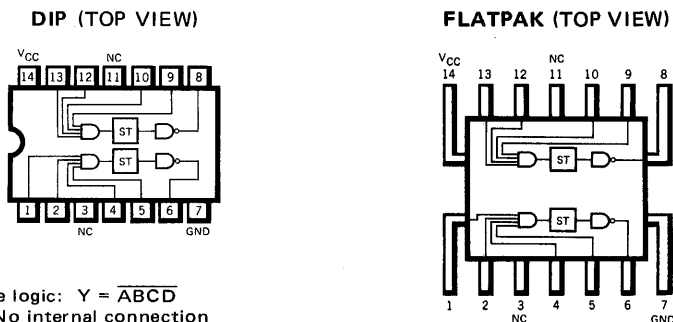

RECOMMENDED OPERATING CONDITIONS

PARAMETER	9N13XM/5413XM			9N13XC/7413XC			UNITS
	MIN.	TYP.	MAX.	MIN.	TYP.	MAX.	
Supply Voltage V_{CC}	4.5	5.0	5.5	4.75	5.0	5.25	Volts
Operating Free Air Temperature Range	-55	25	125	0	25	70	°C
Normalized Fan Out from Each Output, N	HIGH Logic			20			U.L.
	LOW Logic			10			U.L.
Maximum Input Rise and Fall Time	No Restriction			No Restriction			

X = package type; F for Flatpak, D for Ceramic Dip, P for Plastic Dip. See Packaging Information Section for packages available on this product.

ELECTRICAL CHARACTERISTICS OVER OPERATING TEMPERATURE RANGE (Unless Otherwise Noted)

SYMBOL	PARAMETER	LIMITS			UNITS	TEST CONDITIONS (Note 1)	TEST FIGURE
		MIN.	TYP. (Note 2)	MAX.			
V_{T+}	Positive-Going Threshold Voltage	1.5	1.7	2.0	Volts	$V_{CC} = 5.0\text{ V}$	82
V_{T-}	Negative-Going Threshold Voltage	0.6	0.9	1.1	Volts	$V_{CC} = 5.0\text{ V}$	83
$V_{T+} - V_{T-}$	Hysteresis	0.4	0.8		Volts	$V_{CC} = 5.0\text{ V}$	82 & 83
V_{CD}	Input Clamp Diode Voltage			-1.5	Volts	$V_{CC} = \text{MIN.}, I_I = -12\text{ mA}$	85
V_{OH}	Output HIGH Voltage	2.4	3.3		Volts	$V_{CC} = \text{MIN.}, V_{IN} = 0.6\text{ V}, I_{OH} = -0.8\text{ mA}$	83
V_{OL}	Output LOW Voltage		0.22	0.4	Volts	$V_{CC} = \text{MIN.}, V_{IN} = 2.0\text{ V}, I_{OL} = 16\text{ mA}$	82
I_{T+}	Input Current at Positive-Going Threshold		-0.65		mA	$V_{CC} = 5.0\text{ V}, V_{IN} = V_{T+}$	82
I_{T-}	Input Current at Negative-Going Threshold		-0.85		mA	$V_{CC} = 5.0\text{ V}, V_{IN} = V_{T-}$	83
I_I	Input Current at Maximum Input Voltage			1.0	mA	$V_{CC} = \text{MAX.}, V_{IN} = 5.5\text{ V}$	84
I_{IH}	Input HIGH Current			40	μA	$V_{CC} = \text{MAX.}, V_{IN} = 2.4\text{ V}$	84
I_{IL}	Input LOW Current		-1.0	-1.6	mA	$V_{CC} = \text{MAX.}, V_{IN} = 0.4\text{ V}$	85
I_{OS}	Output Short Circuit Current (Note 3)	-18		-55	mA	$V_{CC} = \text{MAX.}$	86
I_{CCH}	Supply Current HIGH		14	23	mA	$V_{CC} = \text{MAX.}, V_{IN} = 0\text{ V}$	87
I_{CCL}	Supply Current LOW		20	32	mA	$V_{CC} = \text{MAX.}, V_{IN} = 4.5\text{ V}$	87

NOTES:
 (1) For conditions shown as MIN. or MAX., use the appropriate value specified under recommended operating conditions for the applicable device type.
 (2) Typical limits are at $V_{CC} = 5.0\text{ V}, 25^\circ\text{C}$.
 (3) Not more than one output should be shorted at a time.

5

SWITCHING CHARACTERISTICS ($T_A = 25^\circ\text{C}$)

SYMBOL	PARAMETER	LIMITS			UNITS	TEST CONDITIONS	TEST FIGURE
		MIN.	TYP.	MAX.			
t_{pLH}	Turn Off Delay Input to Output		18	27	ns	$V_{CC} = 5.0\text{ V}$ $C_L = 15\text{ pF}$ $R_L = 400\Omega$	M
t_{pHL}	Turn On Delay Input to Output		15	22	ns		

TYPICAL CHARACTERISTICS

POSITIVE-GOING THRESHOLD VOLTAGE VERSUS AMBIENT TEMPERATURE

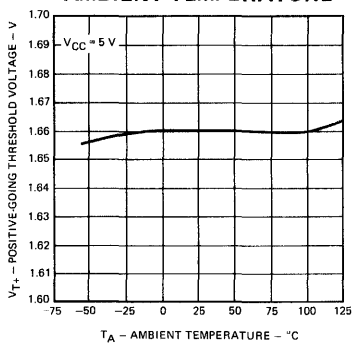

NEGATIVE-GOING THRESHOLD VOLTAGE VERSUS AMBIENT TEMPERATURE

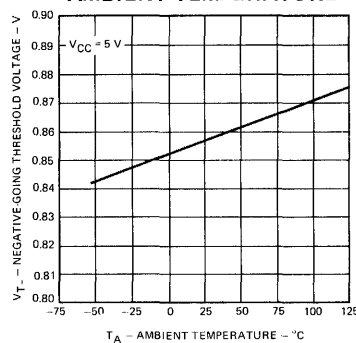

HYSTERESIS VERSUS AMBIENT TEMPERATURE

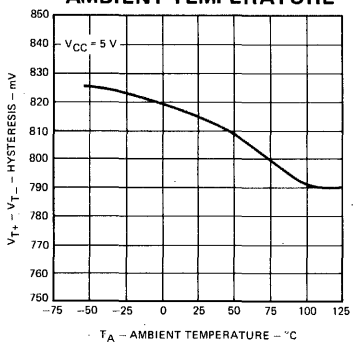

OUTPUT VOLTAGE VERSUS INPUT VOLTAGE

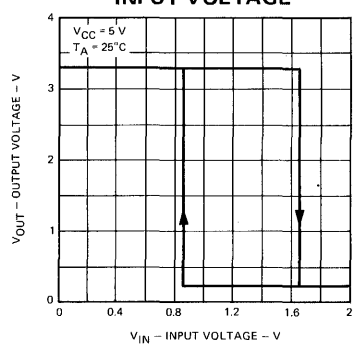

THRESHOLD VOLTAGES AND HYSTERESIS VERSUS SUPPLY VOLTAGE

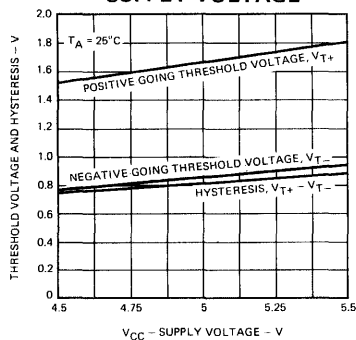

DUAL 4-INPUT NAND GATE

LOGIC AND CONNECTION DIAGRAM

DIP (TOP VIEW)

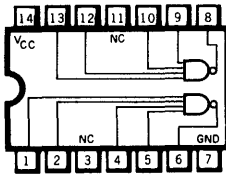

FLATPAK (TOP VIEW)

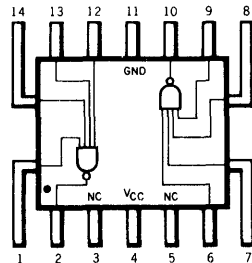

Positive logic: $Y = \overline{ABCD}$

NC — No internal connection.

SCHEMATIC DIAGRAM (EACH GATE)

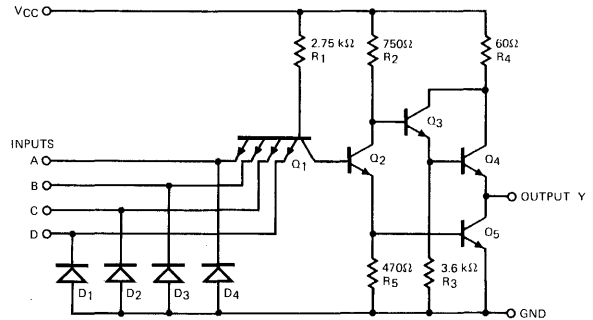

Component values shown are typical.

RECOMMENDED OPERATING CONDITIONS

PARAMETER	9H20XM/54H20XM			9H20XC/74H20XC			UNITS
	MIN.	TYP.	MAX.	MIN.	TYP.	MAX.	
Supply Voltage V_{CC}	4.5	5.0	5.5	4.75	5.0	5.25	Volts
Operating Free-Air Temperature Range	-55	25	125	0	25	70	$^{\circ}$ C
Input Loading for Each Input			1.25			1.25	U.L.

X = package type; F for Flatpak, D for Ceramic Dip, P for Plastic Dip. See Packaging Information Section for packages available on this product.

ELECTRICAL CHARACTERISTICS OVER OPERATING TEMPERATURE RANGE (Unless Otherwise Noted)

SYMBOL	PARAMETER	LIMITS			UNITS	TEST CONDITIONS (Note 1)	TEST FIGURE
		MIN.	TYP. (Note 2)	MAX.			
V_{IH}	Input HIGH Voltage	2.0			Volts	Guaranteed Input HIGH Voltage	1
V_{IL}	Input LOW Voltage			0.8	Volts	Guaranteed Input LOW Voltage	2
V_{OH}	Output HIGH Voltage	2.4			Volts	$V_{CC} = \text{MIN.}, I_{OH} = -0.5 \text{ mA}, V_{IN} = 0.8 \text{ V}$	2
V_{OL}	Output LOW Voltage			0.4	Volts	$V_{CC} = \text{MIN.}, I_{OL} = 20 \text{ mA}, V_{IN} = 2.0 \text{ V}$	1
I_{IH}	Input HIGH Current			50	μ A	$V_{CC} = \text{MAX.}, V_{IN} = 2.4 \text{ V}$	Each Input 4
				1.0	mA	$V_{CC} = \text{MAX.}, V_{IN} = 5.5 \text{ V}$	
I_{IL}	Input LOW Current			-2.0	mA	$V_{CC} = \text{MAX.}, V_{IN} = 0.4 \text{ V}$, Each Input	3
I_{OS}	Output Short Circuit Current (Note 3)	-40		-100	mA	$V_{CC} = \text{MAX.}$	5
I_{CCH}	Supply Current HIGH		5.0	8.4	mA	$V_{CC} = \text{MAX.}, V_{IN} = 0 \text{ V}$	6
I_{CCL}	Supply Current LOW		13	20	mA	$V_{CC} = \text{MAX.}, V_{IN} = 4.5 \text{ V}$	6

SWITCHING CHARACTERISTICS ($T_A = 25^{\circ}$ C)

SYMBOL	PARAMETER	LIMITS			UNITS	TEST CONDITIONS	TEST FIGURE
		MIN.	TYP.	MAX.			
t_{PLH}	Turn Off Delay Input to Output		6.0	10	ns	$V_{CC} = 5.0 \text{ V}$ $C_L = 25 \text{ pF}$ $R_L = 280 \Omega$	T
t_{PHL}	Turn On Delay Input to Output		7.0	10	ns		

NOTES:

(1) For conditions shown as MIN. or MAX., use the appropriate value specified under recommended operating conditions for the applicable device type.

(2) Typical limits are at $V_{CC} = 5.0 \text{ V}$, 25° C.

(3) Not more than one output should be shorted at a time, and duration of short-circuit test should not exceed 1 second.

FAIRCHILD TTL/SSI • 9N20/5420, 7420

DUAL 4-INPUT NAND GATE

LOGIC AND CONNECTION DIAGRAM

DIP (TOP VIEW)

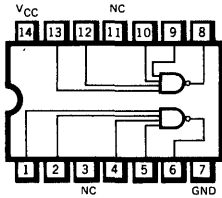

Positive logic: $Y = \overline{ABCD}$

FLATPAK (TOP VIEW)

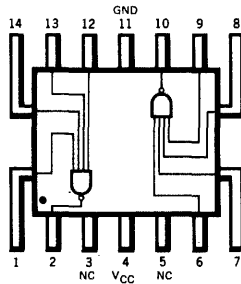

NC — No internal connection.

SCHEMATIC DIAGRAM (EACH GATE)

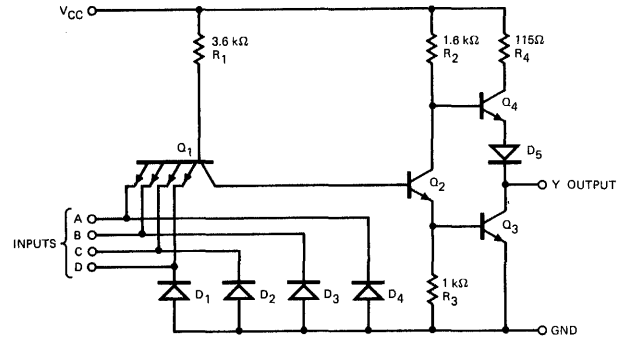

Component values shown are typical.

RECOMMENDED OPERATING CONDITIONS

PARAMETER	9N20XM/5420XM			9N20XC/7420XC			UNITS
	MIN.	TYP.	MAX.	MIN.	TYP.	MAX.	
Supply Voltage V_{CC}	4.5	5.0	5.5	4.75	5.0	5.25	Volts
Operating Free-Air Temperature Range	-55	25	125	0	25	70	$^{\circ}\text{C}$
Normalized Fan Out From Each Output, N			10			10	U.L.

X = package type; F for Flatpak, D for Ceramic Dip, P for Plastic Dip. See Packaging Information Section for packages available on this product.

ELECTRICAL CHARACTERISTICS OVER OPERATING TEMPERATURE RANGE (Unless Otherwise Noted)

SYMBOL	PARAMETER	LIMITS			UNITS	TEST CONDITIONS (Note 1)	TEST FIGURE
		MIN.	TYP. (Note 2)	MAX.			
V_{IH}	Input HIGH Voltage	2.0			Volts	Guaranteed Input HIGH Voltage	1
V_{IL}	Input LOW Voltage			0.8	Volts	Guaranteed Input LOW Voltage	2
V_{OH}	Output HIGH Voltage	2.4	3.3		Volts	$V_{CC} = \text{MIN.}, I_{OH} = -0.4\text{ mA}, V_{IN} = 0.8\text{ V}$	2
V_{OL}	Output LOW Voltage		0.22	0.4	Volts	$V_{CC} = \text{MIN.}, I_{OL} = 16\text{ mA}, V_{IN} = 2.0\text{ V}$	1
I_{IH}	Input HIGH Current			40	μA	$V_{CC} = \text{MAX.}, V_{IN} = 2.4\text{ V}$	Each Input
				1.0	mA	$V_{CC} = \text{MAX.}, V_{IN} = 5.5\text{ V}$	
I_{IL}	Input LOW Current			-1.6	mA	$V_{CC} = \text{MAX.}, V_{IN} = 0.4\text{ V}$, Each Input	3
I_{OS}	Output Short Circuit Current (Note 3)	-20		-55	mA	9N20/5420	$V_{CC} = \text{MAX.}$
		-18		-55	mA	9N20/7420	
I_{CCH}	Supply Current HIGH		2.0	4.0	mA	$V_{CC} = \text{MAX.}, V_{IN} = 0\text{ V}$	6
I_{CCL}	Supply Current LOW		6.0	11	mA	$V_{CC} = \text{MAX.}, V_{IN} = 5.0\text{ V}$	6

SWITCHING CHARACTERISTICS ($T_A = 25^{\circ}\text{C}$)

SYMBOL	PARAMETER	LIMITS			UNITS	TEST CONDITIONS	TEST FIGURE
		MIN.	TYP.	MAX.			
t_{PLH}	Turn Off Delay Input to Output		12	22	ns	$V_{CC} = 5.0\text{ V}$ $C_L = 15\text{ pF}$ $R_L = 400\Omega$	A
t_{PHL}	Turn On Delay Input to Output		8.0	15	ns		

NOTES:

- (1) For conditions shown as MIN. or MAX., use the appropriate value specified under recommended operating conditions for the applicable device type.
- (2) Typical limits are at $V_{CC} = 5.0\text{ V}, 25^{\circ}\text{C}$.
- (3) Not more than one output should be shorted at a time.

FAIRCHILD SUPER HIGH SPEED TTL/SSI • 9S20/54S20, 74S20

DUAL 4-INPUT NAND GATE

LOGIC AND CONNECTION DIAGRAM

DIP (TOP VIEW)

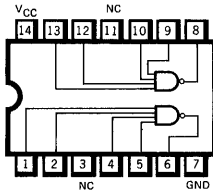

Positive logic: $Y = \overline{ABCD}$

NC—No internal connection.

SCHEMATIC DIAGRAM

(EACH GATE)

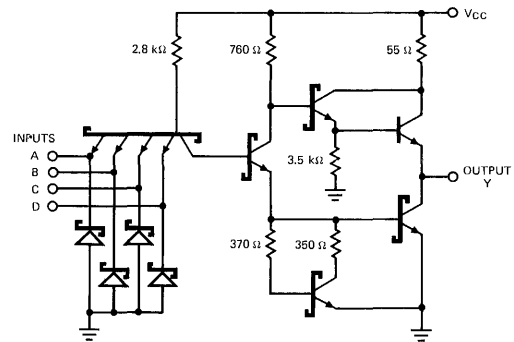

Component values shown are typical.

RECOMMENDED OPERATING CONDITIONS

PARAMETER	9S20XM/54S20XM			9S20XC/74S20XC			UNITS
	MIN.	TYP.	MAX.	MIN.	TYP.	MAX.	
Supply Voltage V_{CC}	4.5	5.0	5.5	4.75	5.0	5.25	Volts
Operating Free-Air Temperature Range	-55	25	125	0	25	75	°C
Input Loading for Each Input			1.25			1.25	U.L.

X = package type; F for Flatpak, D for Ceramic Dip, P for Plastic Dip. See Packaging Information Section for packages available on this product.

ELECTRICAL CHARACTERISTICS OVER OPERATING TEMPERATURE RANGE (Unless Otherwise Noted)

SYMBOL	PARAMETER	LIMITS			UNITS	TEST CONDITIONS (Note 1)
		MIN.	TYP. (Note 2)	MAX.		
V_{IH}	Input HIGH Voltage	2.0			Volts	Guaranteed Input HIGH Voltage
V_{IL}	Input LOW Voltage			0.8	Volts	Guaranteed Input LOW Voltage
V_{CD}	Input Clamp Diode Voltage		-0.65	-1.2	Volts	$V_{CC} = \text{MIN.}, I_{IN} = -18\text{mA}$
V_{OH}	Output HIGH Voltage	XM	2.5	3.4	Volts	$V_{CC} = \text{MIN.}, I_{OH} = -1.0\text{mA}, V_{IN} = 0.8\text{V}$
		XC	2.7	3.4		
V_{OL}	Output LOW Voltage		0.35	0.5	Volts	$V_{CC} = \text{MIN.}, I_{OL} = 20\text{mA}, V_{IN} = 2.0\text{V}$
I_{IH}	Input HIGH Current		1.0	50	μA	$V_{CC} = \text{MAX.}, V_{IN} = 2.7\text{V}$
				1.0	mA	$V_{CC} = \text{MAX.}, V_{IN} = 5.5\text{V}$
I_{IL}	Input LOW Current		-1.4	-2.0	mA	$V_{CC} = \text{MAX.}, V_{IN} = 0.5\text{V}$ Each Input
I_{OS}	Output Short Circuit Current (Note 3)	-40	-65	-100	mA	$V_{CC} = \text{MAX.}, V_{OUT} = 0\text{V}$
I_{CCH}	Supply Current HIGH		5.4	8.0	mA	$V_{CC} = \text{MAX.}, V_{IN} = 0\text{V}$
I_{CCL}	Supply Current LOW		12.6	18.0	mA	$V_{CC} = \text{MAX.}, \text{Inputs Open}$

SWITCHING CHARACTERISTICS ($T_A = 25^\circ\text{C}$)

SYMBOL	PARAMETER	LIMITS			UNITS	TEST CONDITIONS	TEST FIGURES
		MIN.	TYP.	MAX.			
t_{PLH}	Turn Off Delay Input to Output	2.0	3.0	4.5	ns	$V_{CC} = 5.0\text{V}$	DD
t_{PHL}	Turn On Delay Input to Output	2.0	3.0	5.0	ns	$C_L = 15\text{pF}$	

NOTES:

(1) For conditions shown as MIN. or MAX., use the appropriate value specified under recommended operating conditions for the applicable device type.

(2) Typical limits are at $V_{CC} = 5.0\text{V}, 25^\circ\text{C}$.

(3) Not more than one output should be shorted at a time.

FAIRCHILD HIGH SPEED TTL/SSI • 9H21/54H21, 74H21

DUAL 4-INPUT AND GATE

LOGIC AND CONNECTION DIAGRAM

DIP (TOP VIEW)

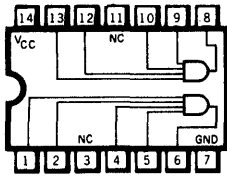

Positive logic: $Y = ABCD$

FLATPAK (TOP VIEW)

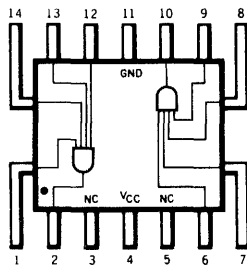

SCHEMATIC DIAGRAM (EACH GATE)

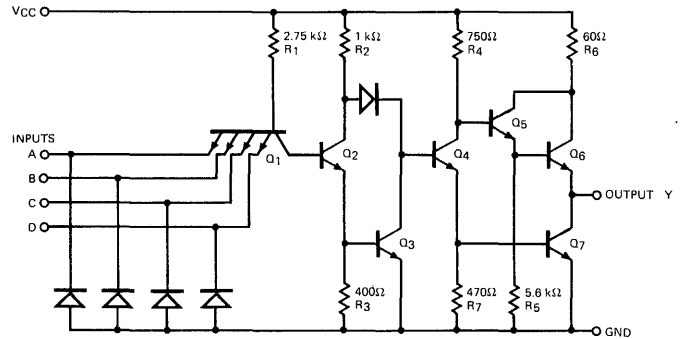

Component values shown are typical.
NC – No internal connection.

RECOMMENDED OPERATING CONDITIONS

PARAMETER	9H21XM/54H21XM			9H21XC/74H21XC			UNITS
	MIN.	TYP.	MAX.	MIN.	TYP.	MAX.	
Supply Voltage V_{CC}	4.5	5.0	5.5	4.75	5.0	5.25	Volts
Operating Free-Air Temperature Range	-55	25	125	0	25	70	°C
Input Loading for Each Input			1.25			1.25	U.L.

X = package type; F for Flatpak, D for Ceramic Dip, P for Plastic Dip. See Packaging Information Section for packages available on this product.

ELECTRICAL CHARACTERISTICS OVER OPERATING TEMPERATURE RANGE (Unless Otherwise Noted)

SYMBOL	PARAMETER	LIMITS			UNITS	TEST CONDITIONS (Note 1)	TEST FIGURE
		MIN.	TYP. (Note 2)	MAX.			
V_{IH}	Input HIGH Voltage	2.0			Volts	Guaranteed Input HIGH Voltage	75
V_{IL}	Input LOW Voltage			0.8	Volts	Guaranteed Input LOW Voltage	77
V_{OH}	Output HIGH Voltage	2.4			Volts	$V_{CC} = \text{MIN.}, I_{OH} = -0.5 \text{ mA}, V_{IN} = 2.0 \text{ V}$	75
V_{OL}	Output LOW Voltage			0.4	Volts	$V_{CC} = \text{MIN.}, I_{OL} = 20 \text{ mA}, V_{IN} = 0.8 \text{ V}$	77
I_{IH}	Input High Current			50	μA	$V_{CC} = \text{MAX.}, V_{IN} = 2.4 \text{ V}$	Each Input 78
					1.0	mA	
I_{IL}	Input LOW Current			-2.0	mA	$V_{CC} = \text{MAX.}, V_{IN} = 0.4 \text{ V}$, Each Input	79
I_{OS}	Output Short Circuit Current (Note 3)	-40		-100	mA	$V_{CC} = \text{MAX.}, V_{IN} = 4.5 \text{ V}$	80
I_{CCH}	Supply Current HIGH		12	20	mA	$V_{CC} = \text{MAX.}, V_{IN} = 4.5 \text{ V}$	81
I_{CCL}	Supply Current LOW		20	32	mA	$V_{CC} = \text{MAX.}, V_{IN} = 0 \text{ V}$	81

SWITCHING CHARACTERISTICS ($T_A = 25^\circ\text{C}$)

SYMBOL	PARAMETER	LIMITS			UNITS	TEST CONDITIONS	TEST FIGURE
		MIN.	TYP.	MAX.			
tPLH	Turn Off Delay Input to Output		7.6	12	ns	$V_{CC} = 5.0 \text{ V}$ $C_L = 25 \text{ pF}$ $R_L = 280 \Omega$	T
tPHL	Turn On Delay Input to Output		8.8	12	ns		

NOTES:

(1) For conditions shown as MIN. or MAX., use the appropriate value specified under recommended operating conditions for the applicable device type.

(2) Typical limits are at $V_{CC} = 5.0 \text{ V}$, 25°C .

(3) Not more than one output should be shorted at a time, and duration of short-circuit test should not exceed 1 second.

FAIRCHILD HIGH SPEED TTL/SSI • 9H22/54H22, 74H22

DUAL 4-INPUT NAND GATE (WITH OPEN-COLLECTOR OUTPUT)

LOGIC AND CONNECTION DIAGRAM

DIP (TOP VIEW)

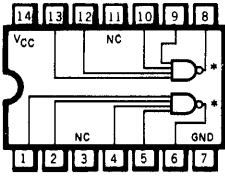

* OPEN COLLECTOR

Positive logic: $Y = \overline{ABCD}$

FLATPAK (TOP VIEW)

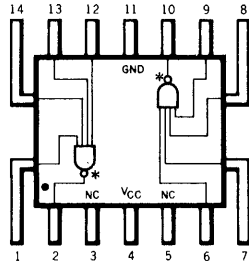

* OPEN COLLECTOR

SCHEMATIC DIAGRAM (EACH GATE)

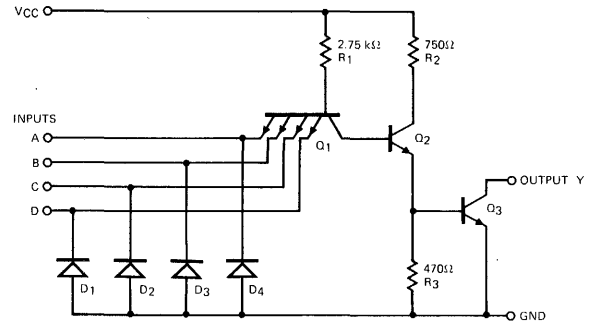

Component values shown are typical.
NC — No internal connection.

RECOMMENDED OPERATING CONDITIONS

PARAMETER	9H22XM/54H22XM			9H22XC/74H22XC			UNITS
	MIN.	TYP.	MAX.	MIN.	TYP.	MAX.	
Supply Voltage V_{CC}	4.5	5.0	5.5	4.75	5.0	5.25	Volts
Operating Free-Air Temperature Range	-55	25	125	0	25	70	$^{\circ}$ C
Input Loading for Each Input			1.25			1.25	U.L.

X = package type; F for Flatpak, D for Ceramic Dip, P for Plastic Dip. See Packaging Information Section for packages available on this product.

ELECTRICAL CHARACTERISTICS OVER OPERATING TEMPERATURE RANGE (Unless Otherwise Noted)

SYMBOL	PARAMETER	LIMITS			UNITS	TEST CONDITIONS (Note 1)	TEST FIGURE
		MIN.	TYP. (Note 2)	MAX.			
V_{IH}	Input HIGH Voltage	2.0			Volts	Guaranteed Input HIGH Voltage	1
V_{IL}	Input LOW Voltage			0.8	Volts	Guaranteed Input LOW Voltage	7
I_{OH}	Output HIGH Current			0.25	mA	$V_{CC} = \text{MIN.}, V_{OH} = 5.5 \text{ V}, V_{IN} = 0.8 \text{ V}$	7
V_{OL}	Output LOW Voltage			0.4	Volts	$V_{CC} = \text{MIN.}, I_{OL} = 20 \text{ mA}, V_{IN} = 2.0 \text{ V}$	1
I_{IH}	Input HIGH Current			50	μ A	$V_{CC} = \text{MAX.}, V_{IN} = 2.4 \text{ V}$	Each Input 4
				1.0	mA	$V_{CC} = \text{MAX.}, V_{IN} = 5.5 \text{ V}$	
I_{IL}	Input LOW Current			-2.0	mA	$V_{CC} = \text{MAX.}, V_{IN} = 0.4 \text{ V}, \text{ Each Input}$	3
I_{CCH}	Supply Current HIGH		3.4	5.0	mA	$V_{CC} = \text{MAX.}, V_{IN} = 0 \text{ V}$	6
I_{CCL}	Supply Current LOW		26	40	mA	$V_{CC} = \text{MAX.}, V_{IN} = 4.5 \text{ V}$	6

SWITCHING CHARACTERISTICS ($T_A = 25^{\circ}$ C)

SYMBOL	PARAMETER	MIN.	LIMITS TYP.	MAX.	UNITS	TEST CONDITIONS	TEST FIGURE
t_{PLH}	Turn Off Delay Input to Output		10	15	ns	$V_{CC} = 5.0 \text{ V}$ $C_L = 25 \text{ pF}$ $R_L = 280 \Omega$	T
t_{PHL}	Turn On Delay Input to Output		7.5	12	ns		

NOTES:

- (1) For conditions shown as MIN. or MAX., use the appropriate value specified under recommended operating conditions for the applicable device type.
- (2) Typical limits are at $V_{CC} = 5.0 \text{ V}, 25^{\circ}$ C.

DUAL 4-INPUT NAND GATE
(WITH OPEN-COLLECTOR OUTPUT)

LOGIC AND CONNECTION DIAGRAM

DIP (TOP VIEW)

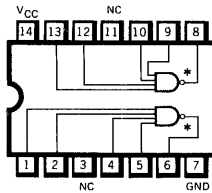

* OPEN COLLECTOR
NC—No internal connection.
Positive logic: $Y = \overline{ABCD}$

SCHEMATIC DIAGRAM

(EACH GATE)

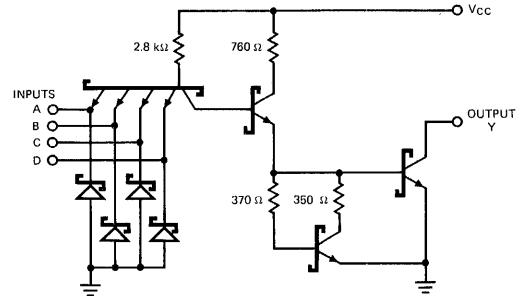

Component values shown are typical.

RECOMMENDED OPERATING CONDITIONS

PARAMETER	† 9S22XM/54S22XM			9S22XC/74S22XC			UNITS
	MIN.	TYP.	MAX.	MIN.	TYP.	MAX.	
Supply Voltage V_{CC}	4.5	5.0	5.5	4.75	5.0	5.25	Volts
Operating Free-Air Temperature Range	-55	25	125	0	25	75	°C
Input Loading for Each Input			1.25			1.25	U.L.

X = package type; F for Flatpak, D for Ceramic Dip, P for Plastic Dip. See Packaging Information Section for packages available on this product.

ELECTRICAL CHARACTERISTICS OVER OPERATING TEMPERATURE RANGE (Unless Otherwise Noted)

SYMBOL	PARAMETER	LIMITS			UNITS	TEST CONDITIONS (Note 1)
		MIN.	TYP. (Note 2)	MAX.		
V_{IH}	Input HIGH Voltage	2.0			Volts	Guaranteed Input HIGH Voltage
V_{IL}	Input LOW Voltage			0.8	Volts	Guaranteed Input LOW Voltage
V_{CD}	Input Clamp Diode Voltage		-0.65	-1.2	Volts	$V_{CC} = \text{MIN.}, I_{IN} = -18\text{mA}$
I_{OH}	Output HIGH Current		0.1	250	μA	$V_{CC} = \text{MIN.}, V_{OH} = 5.5\text{V}, V_{IN} = 0.8\text{V}$
V_{OL}	Output LOW Voltage		0.35	0.5	Volts	$V_{CC} = \text{MIN.}, I_{OL} = 20\text{mA}, V_{IN} = 2.0\text{V}$
I_{IH}	Input HIGH Current		1.0	50	μA	$V_{CC} = \text{MAX.}, V_{IN} = 2.7\text{V}$
				1.0	mA	$V_{CC} = \text{MAX.}, V_{IN} = 5.5\text{V}$
I_{IL}	Input LOW Current		-1.4	-2.0	mA	$V_{CC} = \text{MAX.}, V_{IN} = 0.5\text{V}$
I_{CCH}	Supply Current HIGH		3.0	6.6	mA	$V_{CC} = \text{MAX.}, V_{IN} = 0\text{V}$
I_{CCL}	Supply Current LOW		12.6	18.0	mA	$V_{CC} = \text{MAX.}, \text{Inputs Open}$

SWITCHING CHARACTERISTICS ($T_A = 25^\circ\text{C}$)

SYMBOL	PARAMETER	LIMITS			UNITS	TEST CONDITIONS	TEST FIGURES
		MIN.	TYP.	MAX.			
t_{PLH}	Turn Off Delay Input to Output	2.0	5.0	7.5	ns	$V_{CC} = 5.0\text{V}$	EE
t_{PHL}	Turn On Delay Input to Output	2.0	4.5	7.0	ns	$C_L = 15\text{pF}$	

NOTES:

- (1) For conditions shown as MIN. or MAX., use the appropriate value specified under recommended operating conditions for the applicable device type.
- (2) Typical limits are at $V_{CC} = 5.0\text{V}, 25^\circ\text{C}$.

DUAL 4-INPUT NOR GATE WITH STROBE

LOGIC AND CONNECTION DIAGRAM

9N23/5423, 7423

DIP (TOP VIEW)

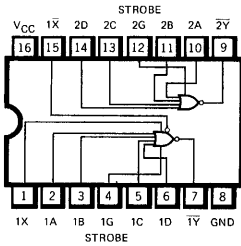

FLATPAK (TOP VIEW)

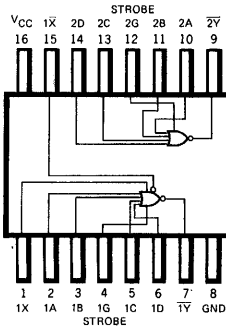

9N25/5425, 7425

DIP (TOP VIEW)

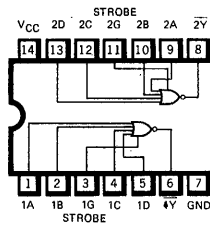

FLATPAK (TOP VIEW)

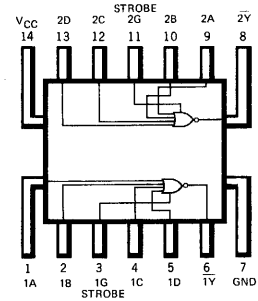

Positive logic:

$$1Y = 1G(1A+1B+1C+1D)+X$$

$$2Y = 2G(2A+2B+2C+2D)$$

X = Output of 9N60/5460, 7460

Positive logic:

$$Y = G(A+B+C+D)$$

SCHEMATIC DIAGRAM (EACH GATE)

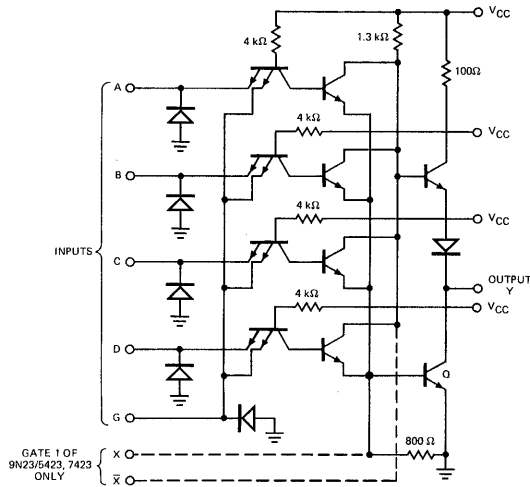

TRUTH TABLE

INPUTS					OUTPUT
A	B	C	D	G	Y
H	X	X	X	H	L
X	H	X	X	H	L
X	X	H	X	H	L
X	X	X	H	H	L
L	L	L	L	X	H
X	X	X	X	L	H

Expander inputs are open.
H = HIGH level, L = LOW level, X = irrelevant

NOTES:

- (a) Component values shown are typical.
- (b) Both expander inputs are used simultaneously for expanding.
- (c) If expander is not used leave X and X open.
- (d) A total of four expander gates can be connected to the expander inputs.

LOGIC DIAGRAM (EACH GATE)

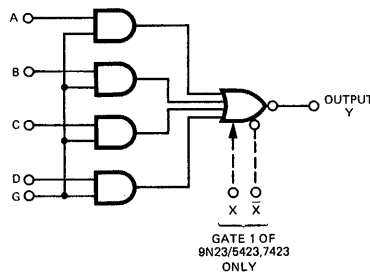

FAIRCHILD TTL/SSI • 9N23/5423, 7423 • 9N25/5425, 7425

RECOMMENDED OPERATING CONDITIONS

PARAMETER	9N23XM/5423XM 9N25XM/5425XM			9N23XC/7423XC 9N25XC/7425XC			UNITS
	MIN.	TYP.	MAX.	MIN.	TYP.	MAX.	
Supply Voltage V_{CC}	4.5	5.0	5.5	4.75	5.0	5.25	Volts
Operating Free-Air Temperature Range	-55	25	125	0	25	70	°C
Normalized Fan Out from Each Output, N	HIGH Level		20			20	U.L.
	LOW Level		10			10	U.L.

X = package type; F for Flatpak, D for Ceramic Dip, P for Plastic Dip. See Packaging Information Section for packages available on this product.

ELECTRICAL CHARACTERISTICS OVER OPERATING TEMPERATURE RANGE (Unless Otherwise Noted)

SYMBOL	PARAMETER	LIMITS			UNITS	TEST CONDITIONS (Note 1)
		MIN.	TYP. (Note 2)	MAX.		
V_{IH}	Input HIGH Voltage	2.0			Volts	Guaranteed Input HIGH Voltage
V_{IL}	Input LOW Voltage			0.8	Volts	Guaranteed Input LOW Voltage
V_{CD}	Input Clamp Diode Voltage			-1.5	Volts	$V_{CC} = \text{MIN.}$, $I_1 = -12 \text{ mA}$
V_{OH}	Output HIGH Voltage	2.4	3.3		Volts	$V_{CC} = \text{MIN.}$, $I_{OH} = -0.8 \text{ mA}$, $V_{IL} = 0.8 \text{ V}$
V_{OL}	Output LOW Voltage		0.22	0.4	Volts	$V_{CC} = \text{MIN.}$, $I_{OL} = 16 \text{ mA}$, $V_{IH} = 2.0 \text{ V}$
I_I	Input Current at Maximum Input Voltage			1.0	mA	$V_{CC} = \text{MAX.}$, $V_{IN} = 5.5 \text{ V}$
I_{IH}	Input HIGH Current			40	μA	Data Inputs
				160	μA	Strobe Inputs
I_{IL}	Input LOW Current			-1.6	mA	Data Inputs
				-6.4	mA	Strobe Inputs
I_{OS}	Output Short Circuit Current (Note 3)	-20		-55	mA	$V_{CC} = \text{MAX.}$
I_{CCH}	Supply Current HIGH		8.0	16	mA	$V_{CC} = \text{MAX.}$, All Input at 0 V
I_{CCL}	Supply Current LOW		10	19	mA	$V_{CC} = \text{MAX.}$, All Input at 5.0 V

ELECTRICAL CHARACTERISTICS (9N23/5423 Circuits Only) Using Expander Inputs, $V_{CC} = 4.5 \text{ V}$, $T_A = -55^\circ\text{C}$

SYMBOL	PARAMETER	LIMITS			UNITS	TEST CONDITIONS	TEST FIGURE
		MIN.	TYP.	MAX.			
I_X	Expander Current			2.9	mA	$V_1 = 0.4 \text{ V}$, $I_{OL} = 16 \text{ mA}$	28
$V_{BE(Q)}$	Base-Emitter Voltage of Output Transistor Q			1.0	Volt	$I_{OL} = 16 \text{ mA}$, $I_1 = 0.41 \text{ mA}$, $R_1 = 0$	29
V_{OH}	Output HIGH Voltage	2.4	3.3		Volts	$I_{OH} = -400 \mu\text{A}$, $I_1 = 0.15 \text{ mA}$, $I_2 = -0.15 \text{ mA}$	30
V_{OL}	Output LOW Voltage		0.22	0.4	Volts	$I_{OL} = 16 \text{ mA}$, $I_1 = 0.3 \text{ mA}$, $R_1 = 138\Omega$	29

ELECTRICAL CHARACTERISTICS (9N23/7423 Circuits Only) Using Expander Inputs, $V_{CC} = 4.75 \text{ V}$, $T_A = 0^\circ\text{C}$

SYMBOL	PARAMETER	LIMITS			UNITS	TEST CONDITIONS	TEST FIGURE
		MIN.	TYP.	MAX.			
I_X	Expander Current			3.1	mA	$V_1 = 0.4 \text{ V}$, $I_{OL} = 16 \text{ mA}$	28
$V_{BE(Q)}$	Base-Emitter Voltage of Output Transistor Q			1.0	Volt	$I_{OL} = 16 \text{ mA}$, $I_1 = 0.62 \text{ mA}$, $R_1 = 0$	29
V_{OH}	Output HIGH Voltage	2.4	3.3		Volts	$I_{OH} = -400 \mu\text{A}$, $I_1 = 0.27 \text{ mA}$, $I_2 = -0.27 \text{ mA}$	30
V_{OL}	Output LOW Voltage		0.22	0.4	Volts	$I_{OL} = 16 \text{ mA}$, $I_1 = 0.43 \text{ mA}$, $R_1 = 130\Omega$	29

SWITCHING CHARACTERISTICS ($T_A = 25^\circ\text{C}$) (Note 4)

SYMBOL	PARAMETER	LIMITS			UNITS	TEST CONDITIONS
		MIN.	TYP.	MAX.		
t_{PLH}	Turn Off Delay Input to Output		13	22	ns	$V_{CC} = 5.0 \text{ V}$ $C_L = 15 \text{ pF}$ $R_L = 400\Omega$
t_{PHL}	Turn On Delay Input to Output		8.0	15	ns	

NOTES:

- For conditions shown as MIN. or MAX., use the appropriate value specified under recommended operating conditions for the applicable device type. Expander inputs X and \bar{X} are open.
- Typical limits are at $V_{CC} = 5.0 \text{ V}$, 25°C .
- Not more than one output should be shorted at a time.
- Switching characteristics of the 9N23/5423, 7423 are tested with the expander pins open.

LPTTL/SSI 9L24

LOW POWER DUAL JK̄ (OR D) FLIP-FLOP

DESCRIPTION — The Low Power TTL/SSI 9L24 consists of two completely independent transition clocked JK̄ flip-flops. The clocking operation is independent of rise and fall times of the clock waveform. The JK̄ design allows operation as a D flip-flop by simply connecting the J and K̄ pins together.

- DUAL RANK TYPE CIRCUIT
- SEPARATE CLOCKS
- SEPARATE ASYNCHRONOUS SET AND CLEAR INPUTS
- 10 MHz TYPICAL TOGGLE FREQUENCY
- TYPICAL POWER DISSIPATION OF 30mW
- INPUT CLAMP DIODES LIMIT HIGH SPEED TERMINATION EFFECTS
- ALL CERAMIC "HERMETIC" 16-LEAD DUAL IN-LINE AND FLAT PACKAGES
- TTL COMPATIBLE

PIN NAMES

J, J ₁ , K̄, K̄ ₁	Flip-Flop Inputs
S̄ _D , S̄ _{D1}	Set Inputs
C̄ _D , C̄ _{D1}	Clear Inputs
CP, CP ₁	Clock Inputs
Q, Q̄, Q ₁ , Q̄ ₁	Flip-Flop Outputs

LOADING

	HIGH	LOW
J, J ₁ , K̄, K̄ ₁	0.5 U.L.	0.25 U.L.
S̄ _D , S̄ _{D1}	1.0 U.L.	0.5 U.L.
C̄ _D , C̄ _{D1}	2.0 U.L.	0.75 U.L.
CP, CP ₁	1.0 U.L.	0.5 U.L.
Q, Q̄, Q ₁ , Q̄ ₁	10 U.L.	2.5 U.L.

1 Unit Load (U.L.) = 40 μA HIGH/1.6 mA LOW.

LOGIC DIAGRAM

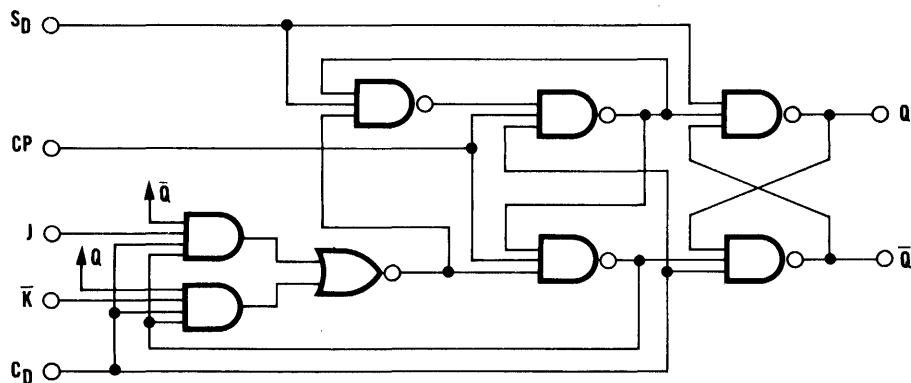

LOGIC SYMBOL

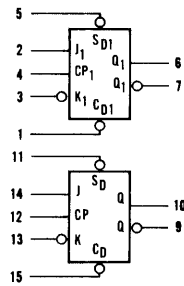

V_{CC} = PIN 16
GND = PIN 8

CONNECTION DIAGRAMS DIP (TOP VIEW)

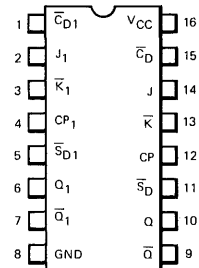

FLATPAK (TOP VIEW)

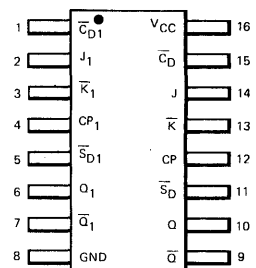

TRUTH TABLES

SYNCHRONOUS ENTRY
J-K̄ MODE OPERATION

INPUTS AT t_n		OUTPUTS AT t_{n+1}	
J	\bar{K}	Q	\bar{Q}
L	H	No Change	
L	L	L	H
H	H	H	L
H	L	Toggles	

t_n = before clock
 t_{n+1} = after clock

SYNCHRONOUS ENTRY
D MODE OPERATION

INPUTS AT t_n	OUTPUTS AT t_{n+1}	
D	Q	\bar{Q}
L	L	H
H	H	L

J & \bar{K} inputs connected together

ASYNCHRONOUS ENTRY INDEPENDENT
OF CLOCK & SYNCHRONOUS INPUTS

INPUTS		OUTPUTS	
\bar{S}_D 5(11)	\bar{C}_D 1(15)	Q 6(10)	\bar{Q} 7(9)
L	L	H	H
L	H	H	L
H	L	L	H
H	H	No Change	

L = LOW Logic Level, H = HIGH Logic Level

TYPICAL INPUT AND OUTPUT CHARACTERISTICS

EQUIVALENT INPUT CIRCUIT

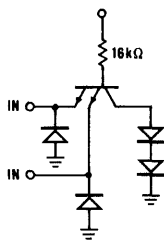

OUTPUT HIGH
EQUIVALENT CIRCUIT

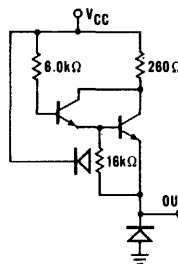

OUTPUT LOW
EQUIVALENT CIRCUIT

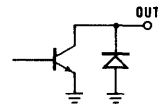

INPUT CURRENT VERSUS
INPUT VOLTAGE

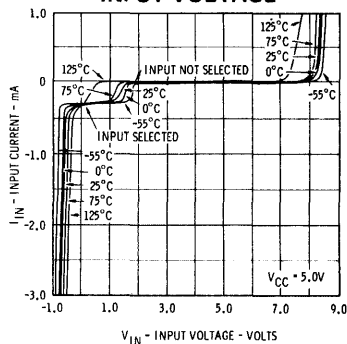

OUTPUT CURRENT VERSUS
OUTPUT VOLTAGE
(OUTPUT HIGH)

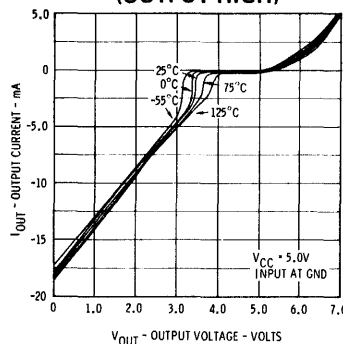

OUTPUT CURRENT VERSUS
OUTPUT VOLTAGE
(OUTPUT LOW)

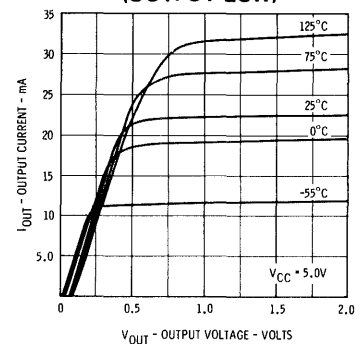

ABSOLUTE MAXIMUM RATINGS (above which the useful life may be impaired)

Storage Temperature	-65°C to +150°C
Temperature (Ambient) Under Bias	-55°C to +125°C
V _{CC} Pin Potential to Ground Pin	-0.5 V to +7.0 V
*Input Voltage (dc)	-0.5 V to +5.5 V
*Input Current (dc)	-30 mA to +5 mA
Voltage Applied to Outputs (Output HIGH)	-0.5 V to +V _{CC} value
Output Current (dc) (Output LOW)	+30 mA

*Either Input Voltage limit or Input Current limit is sufficient to protect the inputs.

GUARANTEED OPERATING RANGES

PART NUMBER	SUPPLY VOLTAGE (V _{CC})			TEMPERATURE
	MIN.	TYP.	MAX.	
9L24XM	4.5 V	5.0 V	5.5 V	-55°C to 125°C
9L24XC	4.75 V	5.0 V	5.25 V	0°C to 75°C

X = package type; F for Flatpak, D for Ceramic Dip, P for Plastic Dip. See Packaging Information Section for packages available on this product.

FAIRCHILD LPTT L/SSI • 9L24

ELECTRICAL CHARACTERISTICS OVER OPERATING TEMPERATURE RANGE (Unless Otherwise Noted)

SYMBOL	PARAMETER	LIMITS			UNITS	CONDITIONS
		MIN.	TYP. (Note 4)	MAX.		
V _{OH}	Output HIGH Voltage	2.4	3.6		Volts	V _{CC} = MIN., I _{OH} = -0.4 mA V _{IN} = V _{IH} or V _{IL} per Truth Table
V _{OL}	Output LOW Voltage		0.1	0.3	Volts	V _{CC} = MIN., I _{OL} = 4.0 mA V _{IN} = V _{IH} or V _{IL} per Truth Table
V _{IH}	Input HIGH Voltage	2.0			Volts	Guaranteed Input HIGH Threshold Voltage for all Inputs.
V _{IL}	Input LOW Voltage			0.7	Volts	Guaranteed Input LOW Threshold Voltage for all Inputs.
I _{IL}	Input LOW Current J, \bar{K} CP, \bar{S}_D \bar{C}_D (Note 3)		-0.25 -0.50 -0.75	-0.4 -0.8 -1.2	mA	V _{CC} = MAX., V _{IN} = 0.3 V.
I _{IH}	Input HIGH Current J, \bar{K} CP, \bar{S}_D \bar{C}_D		2 4 8	20 40 80	μA	V _{CC} = MAX., V _{IN} = 2.4 V.
	Input HIGH Current			1.0	mA	V _{CC} = MAX., V _{IN} = 5.5 V.
I _{SC} (Note 5)	Output Short Circuit Current	-10	-22	-40	mA	V _{CC} = MAX., V _{OUT} = 0.0 V.
I _{CC}	Power Supply Current		6.0	8.8	mA	V _{CC} = MAX.

NOTES:

- (1) Conditions for testing, not shown in the Table, are chosen to guarantee operation under "worst case" conditions.
- (2) The specified LIMITS represent the "worst case" value for the parameter. Since these "worst case" values normally occur at the temperature and supply voltage extremes, additional noise immunity and guard banding can be achieved by decreasing the allowable system operating ranges.
- (3) Denotes maximum current under normal operation. These currents may increase up to 4 I_{IL} if J, \bar{K} = Logic HIGH and \bar{S}_D = Logic LOW.
- (4) Typical limits are at V_{CC} = 5.0 V, 25°C, and max. loading.
- (5) Not more than one output should be shorted at a time.

SWITCHING CHARACTERISTICS (T_A = 25°C, V_{CC} = 5.0 V, C_L = 15 pF)

PARAMETER	LIMITS			UNITS	CONDITIONS
	MIN.	TYP.	MAX.		
t _{PLH} (CP to Q) (CP to \bar{Q})		40 40		ns	J ≥ 2.4 V, \bar{K} ≤ 0.3 V Fig. 2
t _{PHL} (CP to Q) (CP to \bar{Q})		60 60		ns	J ≥ 2.4 V, \bar{K} ≤ 0.3 V Fig. 2
t _{PLH} (S _D to Q) (C _D to \bar{Q})		14 14		ns	J ≥ 2.4 V, \bar{K} ≤ 0.3 V Fig. 3
t _{PHL} (S _D to \bar{Q}) (C _D to Q)		50 40		ns	J ≥ 2.4 V, \bar{K} ≤ 0.3 V Fig. 3
t _s "H" (J to CP) t _r "H" (J to CP)		20 20		ns	\bar{K} ≤ 0.3 V Fig. 1
t _s "H" (\bar{K} to CP) t _r "H" (\bar{K} to CP)		1.0 1.0		ns	J ≥ 2.4 V Fig. 1
t _s "L" (J to CP) t _r "L" (J to CP)		-2.0 -2.0		ns	\bar{K} ≤ 0.3 V Fig. 1
t _s "L" (\bar{K} to CP) t _r "L" (\bar{K} to CP)		9.0 9.0		ns	J ≥ 2.4 V Fig. 1
t _{pw} "H" (Clock Pulse Width) t _{pw} "L" (S _D Pulse Width) t _{pw} "L" (C _D Pulse Width)		40 50 40		ns	J ≥ 2.4 V, \bar{K} ≤ 0.3 V
Toggle Frequency		10		MHz	J ≥ 2.4 V, \bar{K} ≤ 0.3 V



FAIRCHILD LPTT L/SSI • 9L24

SET UP TIME – t_s is defined as the time required for the new logic level to be present at the J or \bar{K} inputs prior to the clock transition from LOW to HIGH in order for the flip-flop to respond to the new $J\bar{K}$ mode.

RELEASE TIME – t_r is defined as the time allowed for a new logic level to be present at the J or \bar{K} inputs prior to the clock transition from LOW to HIGH in order for the flip-flop not to respond to the new $J\bar{K}$ mode. A negative Release Time means the new logic level must not occur until after the clock transition.

SET UP AND RELEASE WAVEFORMS

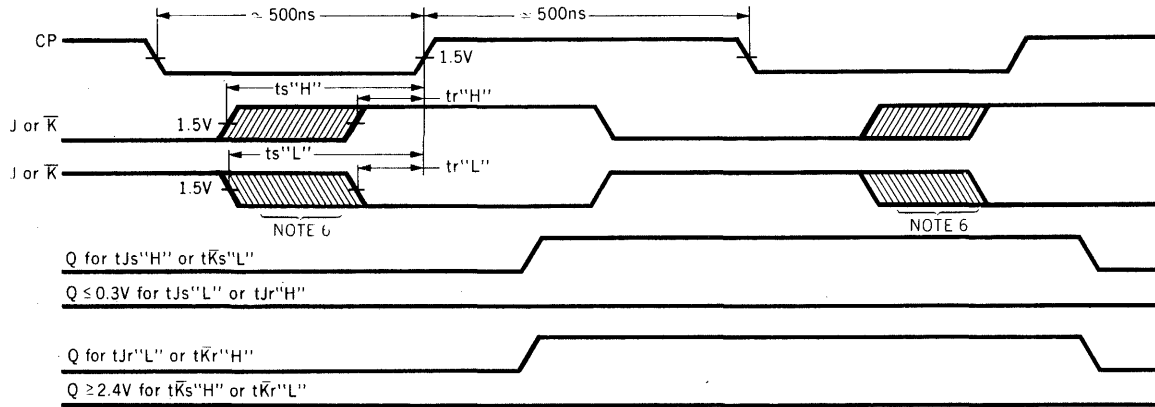

Note (6) FORBIDDEN ZONE, if data changes during the shaded time, the state of the outputs cannot be predetermined.

FIG.1

SWITCHING WAVEFORMS

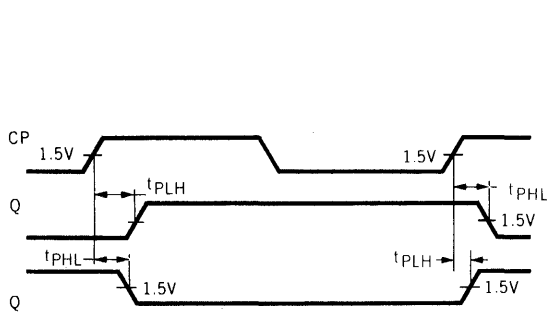

FIG.2

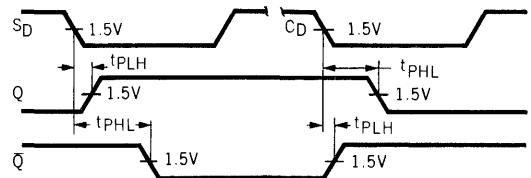

FIG.3

QUAD 2-INPUT HIGH VOLTAGE INTERFACE NAND GATE

DESCRIPTION — These open-collector NAND gates feature high output voltage ratings for interfacing with low threshold voltage MOS logic circuits or other 12V systems. Although the output is rated to withstand 15V, the V_{CC} terminal is connected to the standard 5V source. The output transistor will sink 16 mA while maintaining a low-level output voltage of 0.4V maximum thus providing a high fan out driver with the nominal power dissipation standard Series 9N/54, 74 gates.

LOGIC AND CONNECTION DIAGRAM

DIP (TOP VIEW)

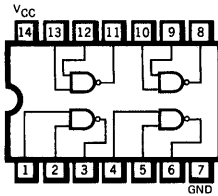

Positive logic: $Y = \overline{AB}$

SCHEMATIC DIAGRAM (EACH GATE)

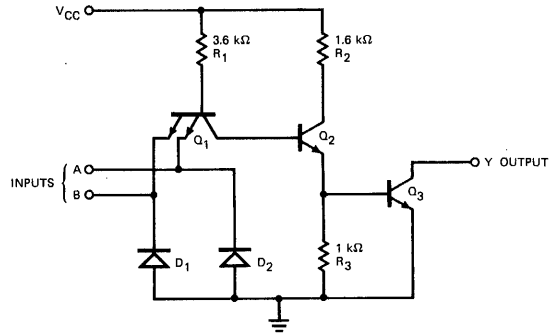

Component values shown are typical.

RECOMMENDED OPERATING CONDITIONS

PARAMETER	9N26XM/5426XM			9N26XC/7426XC			UNITS
	MIN.	TYP.	MAX.	MIN.	TYP.	MAX.	
Supply Voltage V_{CC}	4.5	5.0	5.5	4.75	5.0	5.25	Volts
Output Voltage, V_{OH}			15			15	Volts
LOW Level Output Current, I_{OL}			16			16	mA
Operating Free-Air Temperature Range	-55	25	125	0	25	70	$^{\circ}C$

X = package type; F for Flatpak, D for Ceramic Dip, P for Plastic Dip. See Packaging Information Section for packages available on this product.

ELECTRICAL CHARACTERISTICS OVER OPERATING TEMPERATURE RANGE (Unless Otherwise Noted)

SYMBOL	PARAMETER	LIMITS			UNITS	TEST CONDITIONS (Note 1)	TEST FIGURE	
		MIN.	TYP. (Note 2)	MAX.				
V_{IH}	Input HIGH Voltage	2.0			Volts	Guaranteed Input HIGH Voltage	88	
V_{IL}	Input LOW Voltage			0.8	Volts	Guaranteed Input LOW Voltage	89	
V_{OH}	Output HIGH Voltage	15			Volts	$V_{CC} = \text{MIN.}, V_{IL} = 0.8 \text{ V}, I_{OH} = 1.0 \text{ mA}$	89	
I_{OH}	Output HIGH Current			50	μA	$V_{CC} = \text{MIN.}, V_{IL} = 0.8 \text{ V}, V_{OH} = 12 \text{ V}$	89	
V_{OL}	Output LOW Voltage			0.4	Volts	$V_{CC} = \text{MIN.}, I_{OL} = 16 \text{ mA}, V_{IH} = 2.0 \text{ V}$	88	
I_{IH}	Input HIGH Current			40	μA	$V_{CC} = \text{MAX.}, V_{IN} = 2.4 \text{ V}$	Each Input	90
				1.0	mA	$V_{CC} = \text{MAX.}, V_{IN} = 5.5 \text{ V}$		
I_{IL}	Input LOW Current			-1.6	mA	$V_{CC} = \text{MAX.}, V_{IN} = 0.4 \text{ V}$, Each Input	91	
I_{CCH}	Supply Current HIGH		4.0	8.0	mA	$V_{CC} = \text{MAX.}, V_{IN} = 0 \text{ V}$	92	
I_{CCL}	Supply Current LOW		12	22	mA	$V_{CC} = \text{MAX.}, V_{IN} = 5.0 \text{ V}$	92	

SWITCHING CHARACTERISTICS ($T_A = 25^{\circ}C$)

SYMBOL	PARAMETER	LIMITS			UNITS	TEST CONDITIONS	TEST FIGURE
		MIN.	TYP.	MAX.			
t_{PLH}	Turn Off Delay Input to Output		16	24	ns	$V_{CC} = 5.0 \text{ V}$ $C_L = 15 \text{ pF}$ $R_L = 1.0 \text{ k}\Omega$	N
t_{PHL}	Turn On Delay Input to Output		11	17	ns		

NOTES:

- (1) For conditions shown as MIN. or MAX., use the appropriate value specified under recommended operating conditions for the applicable device type.
- (2) Typical limits are at $V_{CC} = 5.0 \text{ V}, 25^{\circ}C$.

TRIPLE 3-INPUT NOR GATE

LOGIC AND CONNECTION DIAGRAM

DIP (TOP VIEW)

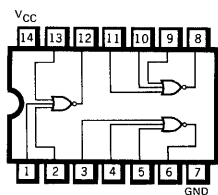

Positive logic: $Y = \overline{A+B+C}$

FLATPAK (TOP VIEW)

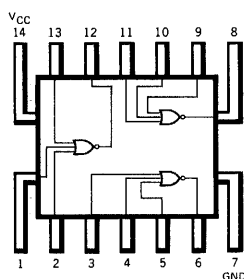

SCHEMATIC DIAGRAM
(EACH GATE)

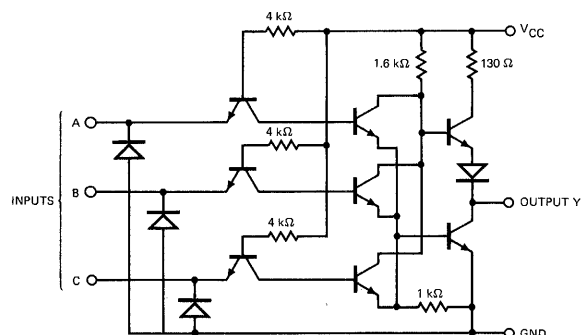

Component values shown are typical.

RECOMMENDED OPERATING CONDITIONS

PARAMETER	9N27XM/5427XM			9N27XC/7427XC			UNITS
	MIN.	TYP.	MAX.	MIN.	TYP.	MAX.	
Supply Voltage V_{CC}	4.5	5.0	5.5	4.75	5.0	5.25	Volts
Operating Free Air Temperature Range	-55	25	125	0	25	70	$^{\circ}C$
Normalized Fan Out from Each Output, N	HIGH Level		20			20	U.L.
	LOW Level		10			10	U.L.

X = package type; F for Flatpak, D for Ceramic Dip, P for Plastic Dip. See Packaging Information Section for packages available on this product.

ELECTRICAL CHARACTERISTICS OVER OPERATING TEMPERATURE RANGE (Unless Otherwise Noted)

SYMBOL	PARAMETER	LIMITS			UNITS	TEST CONDITIONS (Note 1)
		MIN.	TYP. (Note 2)	MAX.		
V_{IH}	Input HIGH Voltage	2.0			Volts	Guaranteed Input HIGH Voltage
V_{IL}	Input LOW Voltage			0.8	Volts	Guaranteed Input LOW Voltage
V_{CD}	Input Clamp Diode Voltage			-1.5	Volts	$V_{CC} = \text{MIN.}, I_I = -12 \text{ mA}$
V_{OH}	Output HIGH Voltage	2.4	3.3			$V_{CC} = \text{MIN.}, I_{OH} = -0.8 \text{ mA}, V_{IL} = 0.8 \text{ V}$
V_{OL}	Output LOW Voltage		0.22	0.4	Volts	$V_{CC} = \text{MIN.}, I_{OL} = 16 \text{ mA}, V_{IH} = 2.0 \text{ V}$
I_I	Input Current at Max. Input Vol.			1.0	mA	$V_{CC} = \text{MAX.}, V_{IN} = 5.5 \text{ V}$
I_{IH}	Input HIGH Current			40	μA	$V_{CC} = \text{MAX.}, V_{IN} = 2.4 \text{ V}$
I_{IL}	Input LOW Current			-1.6	mA	$V_{CC} = \text{MAX.}, V_{IN} = 0.4 \text{ V}$
I_{OS}	Output Short Circuit Current (Note 3)	-20		-55	mA	9N27/5427
		-18		-55	mA	9N27/7427
I_{CCH}	Supply Current HIGH		10	16	mA	$V_{CC} = \text{MAX.},$ (Note 4)
I_{CCL}	Supply Current LOW		16	26	mA	$V_{CC} = \text{MAX.},$ (Note 5)

SWITCHING CHARACTERISTICS ($T_A = 25^{\circ}C$)

SYMBOL	PARAMETER	LIMITS			UNITS	TEST CONDITIONS
		MIN.	TYP.	MAX.		
tPLH	Turn Off Delay Input to Output		10	15	ns	$V_{CC} = 5.0 \text{ V}$ $C_L = 15 \text{ pF}$ $R_L = 400\Omega$
tPHL	Turn On Delay Input to Output		7.0	11	ns	

NOTES:

- (1) For conditions shown as MIN. or MAX., use the appropriate value specified under recommended operating conditions for the applicable device type.
- (2) Typical limits are at $V_{CC} = 5.0 \text{ V}, 25^{\circ}C$.
- (3) Not more than one output should be shorted at a time.
- (4) Measured with all inputs grounded, and outputs open.
- (5) Measured with one input of each gate at 4.5 V, the remaining inputs grounded, and outputs open.

8-INPUT NAND GATE

LOGIC AND CONNECTION DIAGRAM

DIP (TOP VIEW)

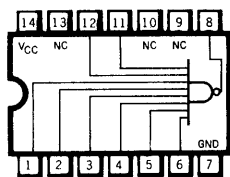

FLATPAK (TOP VIEW)

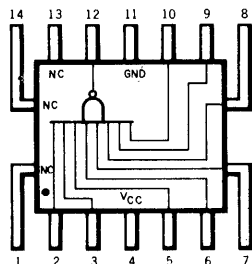

Positive logic: $Y = ABCDEFGH$

SCHEMATIC DIAGRAM (EACH GATE)

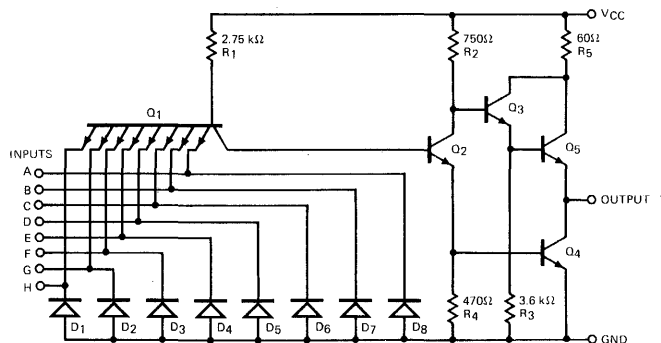

Component values shown are typical.
NC - No internal connection.

RECOMMENDED OPERATING CONDITIONS

PARAMETER	9H30XM/54H30XM			9H30XC/74H30XC			UNITS
	MIN.	TYP.	MAX.	MIN.	TYP.	MAX.	
Supply Voltage V_{CC}	4.5	5.0	5.5	4.75	5.0	5.25	Volts
Operating Free-Air Temperature Range	-55	25	125	0	25	70	$^{\circ}C$
Input Loading for Each Input			1.25			1.25	U.L.

X = package type; F for Flatpak, D for Ceramic Dip, P for Plastic Dip. See Packaging Information Section for packages available on this product.

ELECTRICAL CHARACTERISTICS OVER OPERATING TEMPERATURE RANGE (Unless Otherwise Noted)

SYMBOL	PARAMETER	LIMITS			UNITS	TEST CONDITIONS (Note 1)	TEST FIGURE
		MIN.	TYP. (Note 2)	MAX.			
V_{IH}	Input HIGH Voltage	2.0			Volts	Guaranteed Input HIGH Voltage	1
V_{IL}	Input LOW Voltage			0.8	Volts	Guaranteed Input LOW Voltage	2
V_{OH}	Output HIGH Voltage	2.4			Volts	$V_{CC} = \text{MIN.}, I_{OH} = -0.5 \text{ mA}, V_{IN} = 0.8 \text{ V}$	2
V_{OL}	Output LOW Voltage			0.4	Volts	$V_{CC} = \text{MIN.}, I_{OL} = 20 \text{ mA}, V_{IN} = 2.0 \text{ V}$	1
I_{IH}	Input HIGH Current			50	μA	$V_{CC} = \text{MAX.}, V_{IN} = 2.4 \text{ V}$	Each Input 4
				1.0	mA	$V_{CC} = \text{MAX.}, V_{IN} = 5.5 \text{ V}$	
I_{IL}	Input LOW Current			-2.0	mA	$V_{CC} = \text{MAX.}, V_{IN} = 0.4 \text{ V}$, Each Input	3
I_{OS}	Output Short Circuit Current (Note 3)	-40		-100	mA	$V_{CC} = \text{MAX.}$	5
I_{CCH}	Supply Current HIGH		2.5	4.2	mA	$V_{CC} = \text{MAX.}, V_{IN} = 0 \text{ V}$	6
I_{CCL}	Supply Current LOW		6.5	10	mA	$V_{CC} = \text{MAX.}, V_{IN} = 4.5 \text{ V}$	6

SWITCHING CHARACTERISTICS ($T_A = 25^{\circ}C$)

SYMBOL	PARAMETER	LIMITS			UNITS	TEST CONDITIONS	TEST FIGURE
		MIN.	TYP.	MAX.			
t_{PLH}	Turn Off Delay Input to Output		6.8	10	ns	$V_{CC} = 5.0 \text{ V}$ $C_L = 25 \text{ pF}$ $R_L = 280 \Omega$	T
t_{PHL}	Turn On Delay Input to Output		8.9	12	ns		

NOTES:

(1) For conditions shown as MIN. or MAX., use the appropriate value specified under recommended operating conditions for the applicable device type.

(2) Typical limits are at $V_{CC} = 5.0 \text{ V}, 25^{\circ}C$.

(3) Not more than one output should be shorted at a time, and duration of short-circuit test should not exceed 1 second.

8-INPUT NAND GATE

LOGIC AND CONNECTION DIAGRAM

DIP (TOP VIEW)

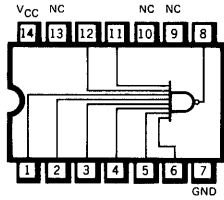

Positive logic: $Y = \overline{ABCDEFGH}$

FLATPAK (TOP VIEW)

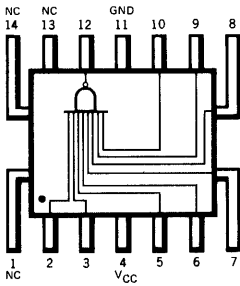

SCHEMATIC DIAGRAM

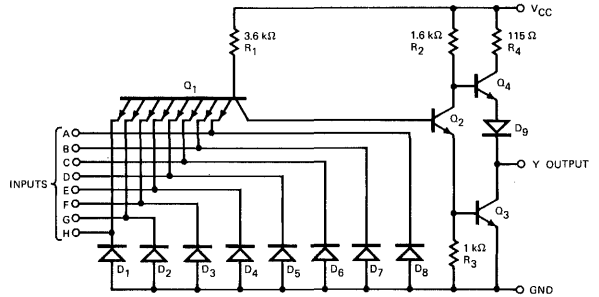

NC — No internal connection.

Component values shown are typical.

RECOMMENDED OPERATING CONDITIONS

PARAMETER	9N30XM/5430XM			9N30XC/7430XC			UNITS
	MIN.	TYP.	MAX.	MIN.	TYP.	MAX.	
Supply Voltage V_{CC}	4.5	5.0	5.5	4.75	5.0	5.25	Volts
Operating Free-Air Temperature Range	-55	25	125	0	25	70	°C
Normalized Fan Out from Each Output, N			10			10	U.L.

X = package type; F for Flatpak, D for Ceramic Dip, P for Plastic Dip. See Packaging Information Section for packages available on this product.

ELECTRICAL CHARACTERISTICS OVER OPERATING TEMPERATURE RANGE (Unless Otherwise Noted)

SYMBOL	PARAMETER	LIMITS			UNITS	TEST CONDITIONS (Note 1)	TEST FIGURE
		MIN.	TYP. (Note 2)	MAX.			
V_{IH}	Input HIGH Voltage	2.0			Volts	Guaranteed Input HIGH Voltage	1
V_{IL}	Input LOW Voltage			0.8	Volts	Guaranteed Input LOW Voltage	2
V_{OH}	Output HIGH Voltage	2.4	3.3		Volts	$V_{CC} = \text{MIN.}, I_{OH} = -0.4 \text{ mA}, V_{IN} = 0.8 \text{ V}$	2
V_{OL}	Output LOW Voltage		0.22	0.4	Volts	$V_{CC} = \text{MIN.}, I_{OL} = 16 \text{ mA}, V_{IN} = 2.0 \text{ V}$	1
I_{IH}	Input HIGH Current			40	μA	$V_{CC} = \text{MAX.}, V_{IN} = 2.4 \text{ V}$	Each Input
				1.0	mA	$V_{CC} = \text{MAX.}, V_{IN} = 5.5 \text{ V}$	
I_{IL}	Input LOW Current			-1.6	mA	$V_{CC} = \text{MAX.}, V_{IN} = 0.4 \text{ V}$, Each Input	3
I_{OS}	Output Short Circuit Current (Note 3)	-20		-55	mA	9N30/5430	$V_{CC} = \text{MAX.}$
		-18		-55	mA	9N30/7430	
I_{CCH}	Supply Current HIGH		1.0	2.0	mA	$V_{CC} = \text{MAX.}, V_{IN} = 0 \text{ V}$	6
I_{CCL}	Supply Current LOW		3.0	6.0	mA	$V_{CC} = \text{MAX.}, V_{IN} = 5.0 \text{ V}$	6

SWITCHING CHARACTERISTICS ($T_A = 25^\circ\text{C}$)

SYMBOL	PARAMETER	LIMITS			UNITS	TEST CONDITIONS	TEST FIGURE
		MIN.	TYP.	MAX.			
t_{PLH}	Turn Off Delay Input to Output		13	22	ns	$V_{CC} = 5.0 \text{ V}$ $C_L = 15 \text{ pF}$ $R_L = 400\Omega$	A
t_{PHL}	Turn On Delay Input to Output		8.0	15	ns		

NOTES:

- (1) For conditions shown as MIN. or MAX., use the appropriate value specified under recommended operating conditions for the applicable device type.
- (2) Typical limits are at $V_{CC} = 5.0 \text{ V}, 25^\circ\text{C}$.
- (3) Not more than one output should be shorted at a time.

QUAD 2-INPUT OR GATE

LOGIC AND CONNECTION DIAGRAM

DIP (TOP VIEW)

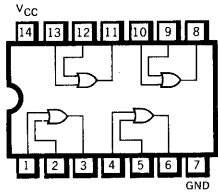

Positive logic: $Y = A + B$

FLATPAK (TOP VIEW)

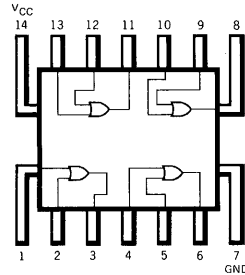

SCHEMATIC DIAGRAM (EACH GATE)

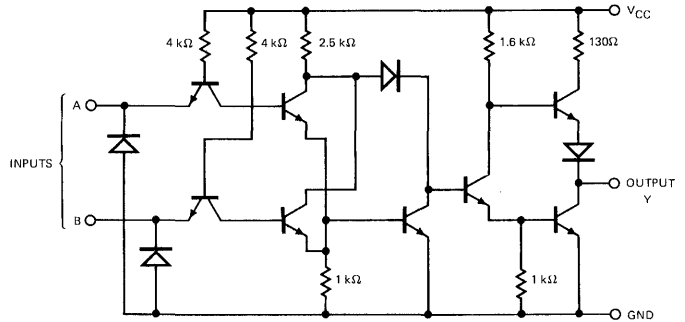

Component values shown are typical.

RECOMMENDED OPERATING CONDITIONS

PARAMETER	9N32XM/5432XM			9N32XC/7432XC			UNITS
	MIN.	TYP.	MAX.	MIN.	TYP.	MAX.	
Supply Voltage V_{CC}	4.5	5.0	5.5	4.75	5.0	5.25	Volts
Operating Free-Air Temperature Range	-55	25	125	0	25	70	$^{\circ}C$
Normalized Fan Out from Each Output, N	HIGH Level			20			U.L.
	LOW Level			10			U.L.

X = package type; F for Flatpak, D for Ceramic Dip, P for Plastic Dip. See Packaging Information Section for packages available on this product.

ELECTRICAL CHARACTERISTICS OVER OPERATING TEMPERATURE RANGE (Unless Otherwise Noted)

SYMBOL	PARAMETER	LIMITS			UNITS	TEST CONDITIONS (Note 1)
		MIN.	TYP. (Note 2)	MAX.		
V_{IH}	Input HIGH Voltage	2.0			Volts	Guaranteed Input HIGH Voltage
V_{IL}	Input LOW Voltage			0.8	Volts	Guaranteed Input LOW Voltage
V_{CD}	Input Clamp Diode Voltage			-1.5	Volts	$V_{CC} = MAX., I_I = -12 mA$
V_{OH}	Output HIGH Voltage	2.4	3.3		Volts	$V_{CC} = MIN., I_{OH} = -0.8 mA, V_{IH} = 2.0 V$
V_{OL}	Output LOW Voltage		0.22	0.4	Volts	$V_{CC} = MIN., I_{OL} = 16 mA, V_{IL} = 0.8 V$
I_I	Input Current at Maximum Input Voltage			1.0	mA	$V_{CC} = MAX., V_{IN} = 5.5 V$
I_{IH}	Input HIGH Current			40	μA	$V_{CC} = MAX., V_{IN} = 2.4 V$
I_{IL}	Input LOW Current			-16	mA	$V_{CC} = MAX., V_{IN} = 0.4 V$
I_{OS}	Output Short Circuit Current (Note 3)	-20		-55	mA	9N32/5432
		-18		-55	mA	9N32/7432
I_{CCH}	Supply Current HIGH		15	22	mA	$V_{CC} = MAX., (Note 4)$
I_{CCL}	Supply Current LOW		23	38	mA	$V_{CC} = MAX., (Note 5)$

SWITCHING CHARACTERISTICS ($T_A = 25^{\circ}C$)

SYMBOL	PARAMETER	LIMITS			UNITS	TEST CONDITIONS
		MIN.	TYP.	MAX.		
t_{PLH}	Turn Off Delay Input to Output		10	15	ns	$V_{CC} = 5.0 V$ $C_L = 15 pF$ $R_L = 400\Omega$
t_{PHL}	Turn On Delay Input to Output		14	22	ns	

NOTES:

- (1) For conditions shown as MIN. or MAX., use the appropriate value specified under recommended operating conditions for the applicable device type.
- (2) Typical limits are at $V_{CC} = 5.0 V, 25^{\circ}C$.
- (3) Not more than one output should be shorted at a time.
- (4) Measured with one input of each gate at 4.5 V, the remaining inputs grounded and outputs open.
- (5) Measured with both inputs of all gates grounded, and outputs open.

QUAD 2-INPUT NAND BUFFER

LOGIC AND CONNECTION DIAGRAM

DIP (TOP VIEW)

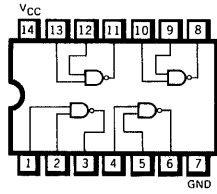

Positive logic: $Y = \overline{AB}$

FLATPAK (TOP VIEW)

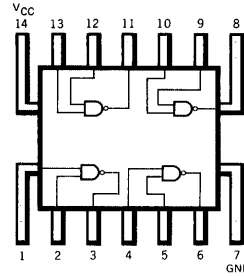

SCHEMATIC DIAGRAM (EACH BUFFER)

9N37/5437, 7437 (TOTEM-POLE OUTPUT)

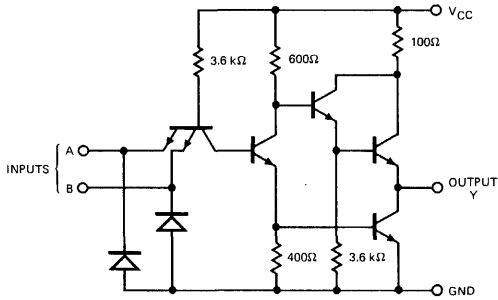

9N38/5438, 7438 (OPEN-COLLECTOR OUTPUT)

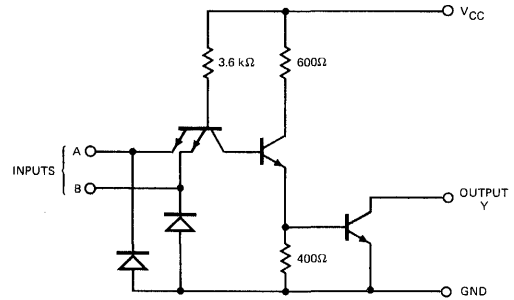

RECOMMENDED OPERATING CONDITIONS

PARAMETER	9N37XM/5437XM 9N38XM/5438XM			9N37XC/7437XC 9N38XC/7438XC			UNITS
	MIN.	TYP.	MAX.	MIN.	TYP.	MAX.	
Supply Voltage V_{CC}	4.5	5.0	5.5	4.75	5.0	5.25	Volts
Operating Free-Air Temperature Range	-55	25	125	0	25	70	°C
Normalized Fan Out from Each Output, N			30			30	U.L.

X = package type; F for Flatpak, D for Ceramic Dip, P for Plastic Dip. See Packaging Information Section for packages available on this product.

9N37/5437, 7437

ELECTRICAL CHARACTERISTICS OVER OPERATING TEMPERATURE RANGE (Unless Otherwise Noted)

SYMBOL	PARAMETER	LIMITS			UNITS	TEST CONDITIONS (Note 1)
		MIN.	TYP. (Note 2)	MAX.		
V _{IH}	Input HIGH Voltage	2.0			Volts	Guaranteed Input HIGH Voltage
V _{IL}	Input LOW Voltage			0.8	Volts	Guaranteed Input LOW Voltage
V _{CD}	Input Clamp Diode Voltage			-1.5	Volts	V _{CC} = MIN., I _I = -12 mA
V _{OH}	Output HIGH Voltage	2.4			Volts	V _{CC} = MIN., I _{OH} = -1.2 mA, V _{IL} = 0.8 V
V _{OL}	Output LOW Voltage		0.22	0.4	Volts	V _{CC} = MIN., I _{OL} = 48 mA, V _{IH} = 2.0 V
I _I	Input Current at Maximum Input Voltage			1.0	mA	V _{CC} = MAX., V _{IN} = 5.5 V
I _{IH}	Input HIGH Current			40	μA	V _{CC} = MAX., V _{IN} = 2.4 V
I _{IL}	Input LOW Current			-1.6	mA	V _{CC} = MAX., V _{IN} = 0.4 V
I _{OS}	Output Short Circuit Current (Note 3)	-20		-70	mA	V _{CC} = MAX., V _{IN} = 0 V
I _{CCH}	Supply Current HIGH		9.0	15.5	mA	V _{CC} = MAX., All Inputs at 0 V
I _{CCL}	Supply Current LOW		34	54	mA	V _{CC} = MAX., All Inputs at 5.0 V

SWITCHING CHARACTERISTICS (T_A = 25°C)

SYMBOL	PARAMETER	LIMITS			UNITS	TEST CONDITIONS
		MIN.	TYP.	MAX.		
t _{PLH}	Turn Off Delay Input to Output		13	22	ns	V _{CC} = 5.0 V C _L = 45 pF R _L = 133Ω
t _{PHL}	Turn On Delay Input to Output		8.0	15	ns	

9N38/5438, 7438

ELECTRICAL CHARACTERISTICS OVER OPERATING TEMPERATURE RANGE (Unless Otherwise Noted)

SYMBOL	PARAMETER	LIMITS			UNITS	TEST CONDITIONS (Note 1)
		MIN.	TYP. (Note 2)	MAX.		
V _{IH}	Input HIGH Voltage	2.0			Volts	Guaranteed Input HIGH Voltage
V _{IL}	Input LOW Voltage			0.8	Volts	Guaranteed Input LOW Voltage
V _{CD}	Input Clamp Diode Voltage			-1.5	Volts	V _{CC} = MIN., I _I = -12 mA
I _{OH}	Output HIGH Current			250	μA	V _{CC} = MIN., V _{OH} = 5.5 V, V _{IL} = 0.8 V
V _{OL}	Output LOW Voltage		0.22	0.4	Volts	V _{CC} = MIN., I _{OL} = 48 mA, V _{IH} = 2.0 V
I _I	Input Current at Maximum Input Voltage			1.0	mA	V _{CC} = MAX., V _{IN} = 5.5 V
I _{IH}	Input HIGH Current			40	μA	V _{CC} = MAX., V _{IN} = 2.4 V
I _{IL}	Input LOW Current			-1.6	mA	V _{CC} = MAX., V _{IN} = 0.4 V
I _{CCH}	Supply Current HIGH		5.0	8.5	mA	V _{CC} = MAX., All Inputs at 0 V
I _{CCL}	Supply Current LOW		34	54	mA	V _{CC} = MAX., All Inputs at 5.0 V

SWITCHING CHARACTERISTICS (T_A = 25°C)

SYMBOL	PARAMETER	LIMITS			UNITS	TEST CONDITIONS
		MIN.	TYP.	MAX.		
t _{PLH}	Turn Off Delay Input to Output		14	22	ns	V _{CC} = 5.0 V C _L = 45 pF R _L = 133Ω
t _{PHL}	Turn On Delay Input to Output		11	18	ns	

NOTES:

- (1) For conditions shown as MIN. or MAX., use the appropriate value specified under recommended operating conditions for the applicable device type.
- (2) Typical limits are at V_{CC} = 5.0 V, 25°C.
- (3) Not more than one output should be shorted at a time, and duration of the short-circuit test should not exceed one second.

QUAD 2-INPUT NAND BUFFER (WITH OPEN COLLECTOR OUTPUT)

LOGIC AND CONNECTION DIAGRAMS
 DIP (TOP VIEW) FLATPAK (TOP VIEW)

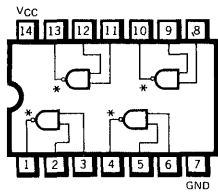

Positive logic: $Y = \overline{AB}$

*Open Collector

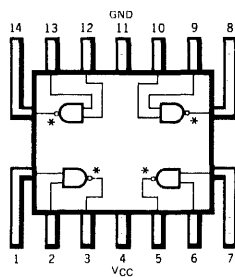

SCHEMATIC DIAGRAM
(EACH GATE)

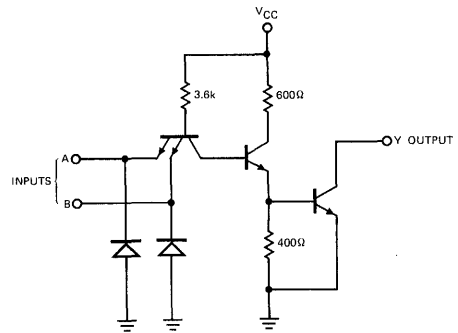

Component values shown are typical.

RECOMMENDED OPERATING CONDITIONS

PARAMETER	9N39XM/5439XM			9N39XC/7439XC			UNITS
	MIN	TYP	MAX	MIN	TYP	MAX	
Supply Voltage V_{CC}	4.5	5.0	5.5	4.75	5.0	5.25	Volts
Operating free-air temperature range	-55	25	125	0	25	70	°C
Normalized fan out from each output, N			30			30	U.L.

X = package type; F for Flatpak, D for Ceramic Dip, P for Plastic Dip. See Packaging Information Section for packages available on this product.

ELECTRICAL CHARACTERISTICS OVER OPERATING TEMPERATURE RANGE (Unless Otherwise Noted)

SYMBOL	PARAMETER	LIMITS			UNITS	TEST CONDITIONS (Note 1)	TEST FIGURE
		MIN	TYP (Note 2)	MAX			
V_{IH}	Input HIGH Voltage	2.0			Volts	Guaranteed Input HIGH Voltage	1
V_{IL}	Input LOW Voltage			0.8	Volts	Guaranteed Input LOW Voltage	7
V_{CD}	Input Clamp Diode Voltage			-1.5	Volts	$V_{CC} = \text{MIN.}$, $I_I = -12 \text{ mA}$, Other Input OPEN	85
I_{OH}	Output HIGH Current			250	μA	$V_{OH} = 5.5 \text{ V}$, $V_{IL} = 0.8 \text{ V}$, $V_{CC} = \text{MIN.}$, Other input = V_{CC}	7
V_{OL}	Output LOW Voltage		0.22	0.4	Volts	$I_{OL} = 48 \text{ mA}$, $V_{CC} = \text{MIN.}$, Other input = 2.0V	1
				0.5	Volts		
	9N39/7439			0.6	Volts		
I_{IH}	Input HIGH Current			40	μA	$V_{CC} = \text{MAX.}$, $V_{IN} = 2.4 \text{ V}$, Other Input = 0 V	4
				1.0	mA	$V_{CC} = \text{MAX.}$, $V_{IN} = 5.5 \text{ V}$, Other Input = 0 V	
I_{IL}	Input LOW Current			-1.6	mA	$V_{CC} = \text{MAX.}$, $V_{IN} = 0.4 \text{ V}$, Other Input = 4.5 V	3
I_{CCH}	Supply Current HIGH		5.0	8.5	mA	$V_{CC} = \text{MAX.}$, All Inputs = 0 V	6
I_{CCL}	Supply Current LOW		34	54	mA	$V_{CC} = \text{MAX.}$, All Inputs = 5.0 V	6

SWITCHING CHARACTERISTICS ($T_A = 25^\circ\text{C}$)

SYMBOL	PARAMETER	LIMITS			UNITS	TEST CONDITIONS	TEST FIGURE
		MIN	TYP	MAX			
t_{PLH}	Turn Off Delay Input to Output		14	22	ns	$V_{CC} = 5.0 \text{ V}$, $C_L = 45 \text{ pF}$, $R_L = 133\Omega$	A
t_{PHL}	Turn On Delay Input to Output		12	18	ns		

NOTES:

(1) For conditions shown as MIN. or MAX., use the appropriate value specified under recommended operating conditions for the applicable device type.

(2) Typical limits are at $V_{CC} = 5.0 \text{ V}$, 25°C .

FAIRCHILD HIGH SPEED TTL/SSI • 9H40/54H40, 74H40

DUAL 4-INPUT NAND BUFFER

LOGIC AND CONNECTION DIAGRAM

DIP (TOP VIEW)

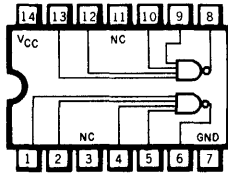

Positive logic: $Y = \overline{ABCD}$

FLATPAK (TOP VIEW)

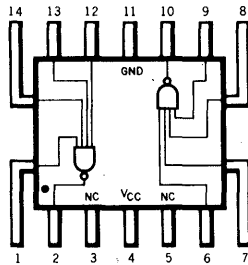

SCHEMATIC DIAGRAM (EACH GATE)

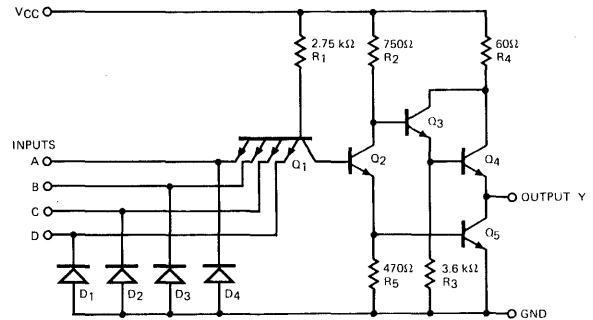

Component values shown are typical.
NC - No internal connection

RECOMMENDED OPERATING CONDITIONS

PARAMETER	9H40XM/54H40XM			9H40XC/74H40XC			UNITS
	MIN.	TYP.	MAX.	MIN.	TYP.	MAX.	
Supply Voltage V_{CC}	4.5	5.0	5.5	4.75	5.0	5.25	Volts
Operating Free-Air Temperature Range	-55	25	125	0	25	70	°C
Fan Out from Each Output			37.5			37.5	U.L.

X = package type; F for Flatpak, D for Ceramic Dip, P for Plastic Dip. See Packaging Information Section for packages available on this product.

ELECTRICAL CHARACTERISTICS OVER OPERATING TEMPERATURE RANGE (Unless Otherwise Noted)

SYMBOL	PARAMETER	LIMITS			UNITS	TEST CONDITIONS (Note 1)	TEST FIGURE	
		MIN.	TYP. (Note 2)	MAX.				
V_{IH}	Input HIGH Voltage	2.0			Volts	Guaranteed Input HIGH Voltage	1	
V_{IL}	Input LOW Voltage			0.8	Volts	Guaranteed Input LOW Voltage	2	
V_{OH}	Output HIGH Voltage	2.4			Volts	$V_{CC} = \text{MIN.}$, $I_{OH} = -1.5 \text{ mA}$, $V_{IN} = 0.8 \text{ V}$	2	
V_{OL}	Output LOW Voltage			0.4	Volts	$V_{CC} = \text{MIN.}$, $I_{OL} = 60 \text{ mA}$, $V_{IN} = 2.0 \text{ V}$	1	
I_{IH}	Input HIGH Current			100	μA	$V_{CC} = \text{MAX.}$, $V_{IN} = 2.4 \text{ V}$ $V_{CC} = \text{MAX.}$, $V_{IN} = 5.5 \text{ V}$	Each Input	4
				1.0	mA			
I_{IL}	Input LOW Current			-4.0	mA	$V_{CC} = \text{MAX.}$, $V_{IN} = 0.4 \text{ V}$, Each Input	3	
I_{OS}	Output Short Circuit Current (Note 3)	-40		-125	mA	$V_{CC} = \text{MAX.}$	5	
I_{CCH}	Supply Current HIGH		10.4	16	mA	$V_{CC} = \text{MAX.}$, $V_{IN} = 0 \text{ V}$	6	
I_{CCL}	Supply Current LOW		25	40	mA	$V_{CC} = \text{MAX.}$, $V_{IN} = 4.5 \text{ V}$	6	

SWITCHING CHARACTERISTICS ($T_A = 25^\circ\text{C}$)

SYMBOL	PARAMETER	LIMITS			UNITS	TEST CONDITIONS	TEST FIGURE
		MIN.	TYP.	MAX.			
t_{PLH}	Turn Off Delay Input to Output		6.5	12	ns	$V_{CC} = 5.0 \text{ V}$ $C_L = 25 \text{ pF}$ $R_L = 93 \Omega$	T
t_{PHL}	Turn On Delay Input to Output		8.5	12	ns		

NOTES:

- (1) For conditions shown as MIN. or MAX., use the appropriate value specified under recommended operating conditions for the applicable device type.
- (2) Typical limits are at $V_{CC} = 5.0 \text{ V}$, 25°C .
- (3) Not more than one output should be shorted at a time, and duration of short-circuit test should not exceed 1 second.

FAIRCHILD TTL/SSI • 9N40/5440, 7440

DUAL 4-INPUT NAND BUFFER

LOGIC AND CONNECTION DIAGRAM

DIP (TOP VIEW)

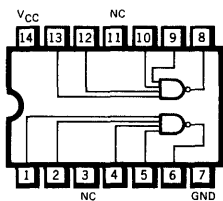

Positive logic: $Y = \overline{ABCD}$

FLATPAK (TOP VIEW)

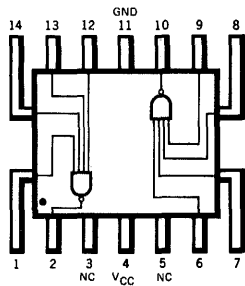

NC – No internal connection.

SCHEMATIC DIAGRAM (EACH GATE)

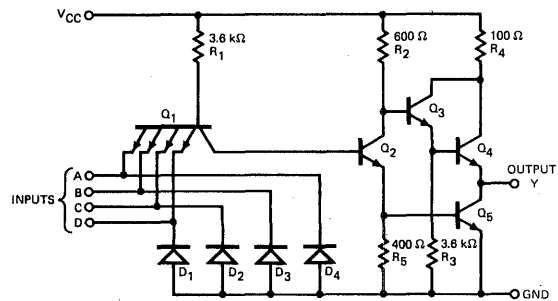

Component values shown are typical.

RECOMMENDED OPERATING CONDITIONS

PARAMETER	9N40XM/5450XM			9N40XC/7440XC			UNITS
	MIN.	TYP.	MAX.	MIN.	TYP.	MAX.	
Supply Voltage V_{CC}	4.5	5.0	5.5	4.75	5.0	5.25	Volts
Operating Free-Air Temperature Range	-55	25	125	0	25	70	$^{\circ}\text{C}$
Normalized Fan Out from Each Output, N			30			30	U.L.

X = package type; F for Flatpak, D for Ceramic Dip, P for Plastic Dip. See Packaging Information Section for packages available on this product.

ELECTRICAL CHARACTERISTICS OVER OPERATING TEMPERATURE RANGE (Unless Otherwise Noted)

SYMBOL	PARAMETER	LIMITS			UNITS	TEST CONDITIONS (Note 1)	TEST FIGURE
		MIN.	TYP. (Note 2)	MAX.			
V_{IH}	Input HIGH Voltage	2.0			Volts	Guaranteed Input HIGH Voltage	1
V_{IL}	Input LOW Voltage			0.8	Volts	Guaranteed Input LOW Voltage	2
V_{OH}	Output HIGH Voltage	2.4	3.3		Volts	$V_{CC} = \text{MIN.}, I_{OH} = -1.2 \text{ mA}, V_{IN} = 0.8 \text{ V}$	2
V_{OL}	Output LOW Voltage		0.28	0.4	Volts	$V_{CC} = \text{MIN.}, I_{OL} = 48 \text{ mA}, V_{IN} = 2.0 \text{ V}$	1
I_{IH}	Input HIGH Current			40	μA	$V_{CC} = \text{MAX.}, V_{IN} = 2.4 \text{ V}$	Each Input
				1.0	mA	$V_{CC} = \text{MAX.}, V_{IN} = 5.5 \text{ V}$	
I_{IL}	Input LOW Current			-1.6	mA	$V_{CC} = \text{MAX.}, V_{IN} = 0.4 \text{ V}$, Each Input	3
I_{OS}	Output Short Circuit Current (Note 3)	-20		-70	mA	$V_{CC} = \text{MAX.}$	5
		-18		-70	mA		
I_{CCH}	Supply Current HIGH		4.0	8.0	mA	$V_{CC} = \text{MAX.}, V_{IN} = 0 \text{ V}$	6
I_{CCL}	Supply Current LOW		17	27	mA	$V_{CC} = \text{MAX.}, V_{IN} = 5.0 \text{ V}$	6

SWITCHING CHARACTERISTICS ($T_A = 25^{\circ}\text{C}$)

SYMBOL	PARAMETER	LIMITS			UNITS	TEST CONDITIONS	TEST FIGURE
		MIN.	TYP.	MAX.			
t_{pLH}	Turn Off Delay Input to Output		13	22	ns	$V_{CC} = 5.0 \text{ V}$ $C_L = 15 \text{ pF}$ $R_L = 133 \Omega$	A
t_{pHL}	Turn On Delay Input to Output		8.0	15	ns		

NOTES:

- (1) For conditions shown as MIN. or MAX., use the appropriate value specified under recommended operating conditions for the applicable device type.
- (2) Typical limits are at $V_{CC} = 5.0 \text{ V}$, 25°C .
- (3) Not more than one output should be shorted at a time.

FAIRCHILD SUPER HIGH SPEED TTL/SSI • 9S40/54S40, 74S40

DUAL 4-INPUT NAND BUFFER

LOGIC AND CONNECTION DIAGRAM

DIP (TOP VIEW)

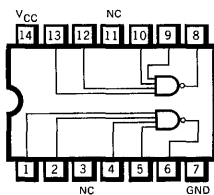

NC—No internal connection.

Positive logic: $Y = \overline{ABCD}$

SCHEMATIC DIAGRAM

(EACH GATE)

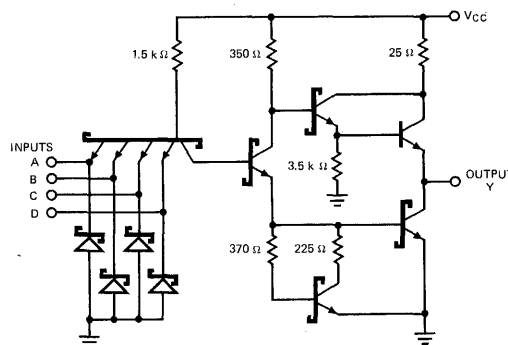

Component values shown are typical.

RECOMMENDED OPERATING CONDITIONS

PARAMETER	9S40XM/54S40XM			9S40XC/74S40XC			UNITS
	MIN.	TYP.	MAX.	MIN.	TYP.	MAX.	
Supply Voltage V_{CC}	4.5	5.0	5.5	4.75	5.0	5.25	Volts
Operating Free-Air Temperature Range	-55	25	125	0	25	75	°C
Fan Out From Each Output			37.5*			37.5*	U.L.

*37.5 (U.L.) is the LOW drive factor and 75 (U.L.) is the HIGH drive factor.

X = package type; F for Flatpak, D for Ceramic Dip, P for Plastic Dip. See Packaging Information Section for packages available on this product.

ELECTRICAL CHARACTERISTICS OVER OPERATING TEMPERATURE RANGE (Unless Otherwise Noted)

SYMBOL	PARAMETER	LIMITS			UNITS	TEST CONDITIONS (Note 1)
		MIN.	TYP. (Note 2)	MAX.		
V_{IH}	Input HIGH Voltage	2.0			Volts	Guaranteed Input HIGH Voltage
V_{IL}	Input LOW Voltage			0.8	Volts	Guaranteed Input LOW Voltage
V_{CD}	Input Clamp Diode Voltage		-0.65	-1.2	Volts	$V_{CC} = \text{MIN.}, I_{IN} = -18\text{mA}$
V_{OH}	Output HIGH Voltage	XM	2.5	3.4	Volts	$V_{CC} = \text{MIN.}, I_{OH} = -3.0\text{mA}, V_{IN} = 0.8\text{V}$
		XC	2.7	3.4		
V_{OL}	Output LOW Voltage		0.4	0.5	Volts	$V_{CC} = \text{MIN.}, I_{OL} = 60\text{mA}, V_{IN} = 2.0\text{V}$
I_{IH}	Input HIGH Current		1.0	100	μA	$V_{CC} = \text{MAX.}, V_{IN} = 2.7\text{V}$
				1.0	mA	$V_{CC} = \text{MAX.}, V_{IN} = 5.5\text{V}$
I_{IL}	Input LOW Current		-2.5	-4.0	mA	$V_{CC} = \text{MAX.}, V_{IN} = 0.5\text{V}$
I_{OS}	Output Short Circuit Current (Note 3)	-50	-150	-225	mA	$V_{CC} = \text{MAX.}, V_{OUT} = 0\text{V}$
I_{CCH}	Supply Current HIGH		8.2	18.0	mA	$V_{CC} = \text{MAX.}, V_{IN} = 0\text{V}$
I_{CCL}	Supply Current LOW		27.2	44.0	mA	$V_{CC} = \text{MAX.}, \text{Inputs Open}$

SWITCHING CHARACTERISTICS ($T_A = 25^\circ\text{C}$)

SYMBOL	PARAMETER	LIMITS			UNITS	TEST CONDITIONS	TEST FIGURES
		MIN.	TYP.	MAX.			
t_{PLH}	Turn Off Delay Input to Output	2.0	4.0	6.5	ns	$V_{CC} = 5.0\text{V}$	DD
t_{PHL}	Turn On Delay Input to Output	2.0	4.0	6.5	ns	$C_L = 50\text{pF}$	

NOTES:

(1) For conditions shown as MIN. or MAX., use the appropriate value specified under recommended operating conditions for the applicable device type.

(2) Typical limits are at $V_{CC} = 5.0\text{V}, 25^\circ\text{C}$.

(3) Not more than one output should be shorted at a time.

DUAL 2-WIDE 2-INPUT AND-OR-INVERT GATE

LOGIC AND CONNECTION DIAGRAM

SCHEMATIC DIAGRAM
(EACH GATE)

DIP (TOP VIEW)

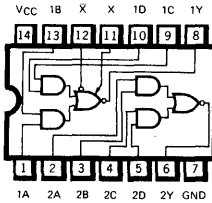

FLATPAK (TOP VIEW)

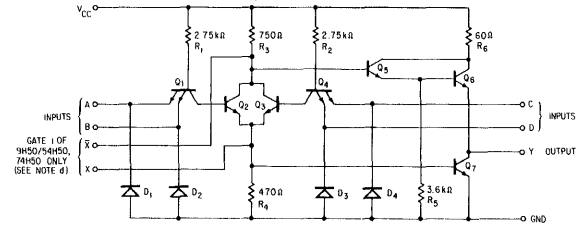
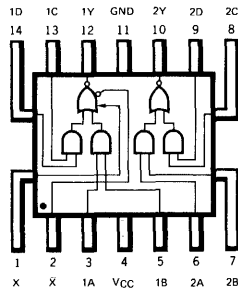

Positive logic: $Y = (\overline{AB}) + (\overline{CD}) + (\overline{X})$
 (X = Output of 9H60/54H60, 74H60 or 9H62/54H62, 74H62)

NOTES:

- (a) Component values shown are typical.
- (b) Both expander inputs are used simultaneously for expanding.
- (c) If expander is not used leave X and \overline{X} pins open.
- (d) Expander inputs X and \overline{X} are functional on the 9H50/54H50, 74H50 circuits only. Make no external connection to X and \overline{X} pins of the 9H51/54H51, 74H51.
- (e) A total of four 9H60/54H60, 74H60 expander gates or one 9H62/54H62, 74H62 expander gate may be connected to the expander inputs.

RECOMMENDED OPERATING CONDITIONS

PARAMETER	9H50XM/54H50XM 9H51XM/54H51XM			9H50XC/74H50XC 9H51XC/74H51XC			UNITS
	MIN.	TYP.	MAX.	MIN.	TYP.	MAX.	
Supply Voltage V_{CC}	4.5	5.0	5.5	4.75	5.0	5.25	Volts
Operating Free-Air Temperature Range	-55	25	125	0	25	70	°C
Input Loading for Each Input			1.25			1.25	U.L.

X = package type; F for Flatpak, D for Ceramic Dip, P for Plastic Dip. See Packaging Information Section for packages available on this product.

ELECTRICAL CHARACTERISTICS OVER OPERATING TEMPERATURE RANGE (Unless Otherwise Noted)

SYMBOL	PARAMETER	LIMITS			UNITS	TEST CONDITIONS (Note 1)	TEST FIGURE
		MIN.	TYP. (Note 2)	MAX.			
V_{IH}	Input HIGH Voltage (Note 4)	2.0			Volts	Guaranteed Input HIGH Voltage	21
V_{IL}	Input LOW Voltage (Note 5)			0.8	Volts	Guaranteed Input LOW Voltage	22
V_{OH}	Output HIGH Voltage	2.4			Volts	$V_{CC} = \text{MIN.}, I_{OH} = -0.5 \text{ mA}, V_{IN} = 0.8 \text{ V}$	22
V_{OL}	Output LOW Voltage			0.4	Volts	$V_{CC} = \text{MIN.}, I_{OL} = 20 \text{ mA}, V_{IN} = 2.0 \text{ V}$	21
I_{IH}	Input HIGH Current			50	μA	$V_{CC} = \text{MAX.}, V_{IN} = 2.4 \text{ V}$ $V_{CC} = \text{MAX.}, V_{IN} = 5.5 \text{ V}$	Each Input 24
I_{IL}	Input LOW Current			-2.0	mA		
I_{OS}	Output Short Circuit Current (Note 3)	-40		-100	mA	$V_{CC} = \text{MAX.}$	25
I_{CCH}	Supply Current HIGH		8.2	12.8	mA	$V_{CC} = \text{MAX.}, V_{IN} = 0 \text{ V}$	27
I_{CCL}	Supply Current LOW		15.2	24	mA	$V_{CC} = \text{MAX.}, V_{IN} = 4.5 \text{ V}$	26

NOTES:

- (1) For conditions shown as MIN. or MAX., use the appropriate value specified under recommended operating conditions for the applicable device type. Expander pins are open.
- (2) Typical limits are at $V_{CC} = 5.0 \text{ V}, 25^\circ\text{C}$.
- (3) Not more than one output should be shorted at a time, and duration of short-circuit test should not exceed 1 second.
- (4) Required at both input terminals of either AND section to ensure LOW level at output.
- (5) Required at one input terminal of each AND section to ensure HIGH level at output.

FAIRCHILD HIGH SPEED TTL/SSI • 9H50/54H50, 74H50 • 9H51/54H51, 74H51

ELECTRICAL CHARACTERISTICS (9H50/54H50 Circuits Only) Using Expander Inputs, $V_{CC} = 4.5\text{ V}$, $T_A = -55^\circ\text{C}$

SYMBOL	PARAMETER	LIMITS			UNITS	TEST CONDITIONS	TEST FIGURE
		MIN.	TYP.	MAX.			
$I_{IN\bar{X}}$	Expander-Node Input Current			-5.85	mA	$V_{\bar{X}} = 1.4\text{ V}$	104
$V_{BE(Q)}$	Base-Emitter Voltage of Output Transistor Q			1.0	Volts	$I_{OL} = 20\text{ mA}$, $I_1 = 700\text{ }\mu\text{A}$, $R_1 = 0\Omega$	29
V_{OH}	Output HIGH Voltage	2.4			Volts	$I_{OH} = -500\text{ }\mu\text{A}$, $I_1 = 320\text{ }\mu\text{A}$, $I_2 = -320\text{ }\mu\text{A}$	30
V_{OL}	Output LOW Voltage			0.4	Volts	$I_{OL} = 20\text{ mA}$, $I_1 = 470\text{ }\mu\text{A}$, $R_1 = 68\Omega$	29

ELECTRICAL CHARACTERISTICS (9H50/74H50 Circuits Only) Using Expander Inputs, $V_{CC} = 4.75\text{ V}$, $T_A = 0^\circ\text{C}$

SYMBOL	PARAMETER	LIMITS			UNITS	TEST CONDITIONS	TEST FIGURE
		MIN.	TYP.	MAX.			
$I_{IN\bar{X}}$	Expander-Node Input Current			-6.3	mA	$V_{\bar{X}} = 1.4\text{ V}$	104
$V_{BE(Q)}$	Base-Emitter Voltage of Output Transistor Q			1.0	Volts	$I_{OL} = 20\text{ mA}$, $I_1 = 1.1\text{ mA}$, $R_1 = 0\Omega$	29
V_{OH}	Output HIGH Voltage	2.4			Volts	$I_{OH} = -500\text{ }\mu\text{A}$, $I_1 = 570\text{ }\mu\text{A}$, $I_2 = -570\text{ }\mu\text{A}$	30
V_{OL}	Output LOW Voltage			0.4	Volts	$I_{OL} = 20\text{ mA}$, $I_1 = 600\text{ }\mu\text{A}$, $R_1 = 63\Omega$	29

SWITCHING CHARACTERISTICS, Expander Pins are Open ($T_A = 25^\circ\text{C}$)

SYMBOL	PARAMETER	LIMITS			UNITS	TEST CONDITIONS	TEST FIGURE
		MIN.	TYP.	MAX.			
t_{PLH}	Turn Off Delay Input to Output		6.8	11	ns	$V_{CC} = 5.0\text{ V}$ $C_L = 25\text{ pF}$ $R_L = 280\Omega$	T
t_{PHL}	Turn On Delay Input to Output		6.2	11	ns		

SWITCHING CHARACTERISTICS (9H50/54H50, 74H50 Circuits Only) ($T_A = 25^\circ\text{C}$)

SYMBOL	PARAMETER	LIMITS			UNITS	TEST CONDITIONS	TEST FIGURE
		MIN.	TYP.	MAX.			
t_{PLH}	Turn Off Delay Input to Output		11		ns	$V_{CC} = 5.0\text{ V}$ $C_L = 25\text{ pF}$ $R_L = 280\Omega$ $*C_X = 15\text{ pF}$	U *MM & NN
t_{PHL}	Turn On Delay Input to Output		7.4		ns		

EXPANDABLE DUAL 2-WIDE 2-INPUT AND-OR-INVERT GATE

LOGIC AND CONNECTION DIAGRAM

DIP (TOP VIEW)

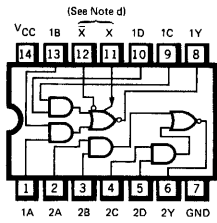

FLATPAK (TOP VIEW)

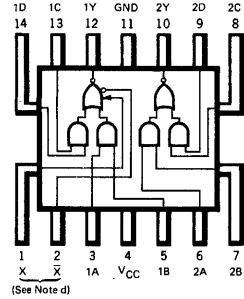

SCHEMATIC DIAGRAM (EACH GATE)

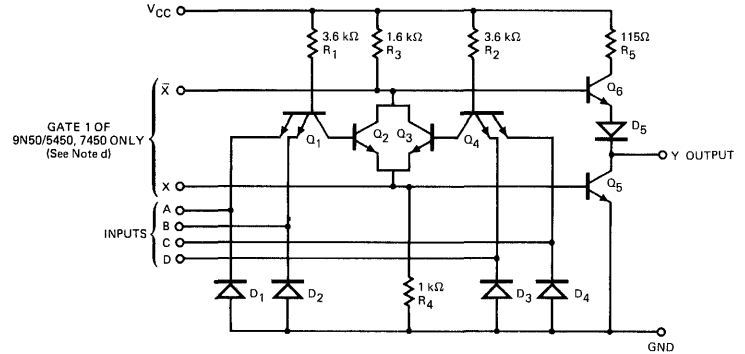

Positive logic: $Y = (AB) + (CD) + (X)$
 (X = Output of 9N60/5460, 7460)

NOTES:

- (a) Component values shown are typical.
- (b) Both expander inputs are used simultaneously for expanding.
- (c) If expander is not used leave X and \bar{X} pins open.
- (d) Make no external connection to X and \bar{X} pins of the 9N51/5451, 7451.
- (e) A total of four expander gates can be connected to the expander inputs.

RECOMMENDED OPERATING CONDITIONS

PARAMETER	9N50XM/5450XM 9N51XM/5451XM			9N50XC/7450XC 9N51XC/7451XC			UNITS
	MIN.	TYP.	MAX.	MIN.	TYP.	MAX.	
Supply Voltage V_{CC}	4.5	5.0	5.5	4.75	5.0	5.25	Volts
Operating Free-Air Temperature Range	-55	25	125	0	25	70	°C
Normalized Fan Out from Each Output, N			10			10	U.L.

X = package type; F for Flatpak, D for Ceramic Dip, P for Plastic Dip. See Packaging Information Section for packages available on this product.

ELECTRICAL CHARACTERISTICS OVER OPERATING TEMPERATURE RANGE (Unless Otherwise Noted)

SYMBOL	PARAMETER	LIMITS			UNITS	TEST CONDITIONS (Note 1)	TEST FIGURE	
		MIN.	TYP. (Note 2)	MAX.				
V_{IH}	Input HIGH Voltage (Note 4)	2.0			Volts	Guaranteed Input HIGH Voltage	21	
V_{IL}	Input LOW Voltage (Note 5)			0.8	Volts	Guaranteed Input LOW Voltage	22	
V_{OH}	Output HIGH Voltage	2.4	3.3		Volts	$V_{CC} = \text{MIN.}, I_{OH} = -0.4 \text{ mA}, V_{IN} = 0.8 \text{ V}$	22	
V_{OL}	Output LOW Voltage		0.22	0.4	Volts	$V_{CC} = \text{MIN.}, I_{OL} = 16 \text{ mA}, V_{IN} = 2.0 \text{ V}$	21	
I_{IH}	Input HIGH Current			40	μA	$V_{CC} = \text{MAX.}, V_{IN} = 2.4 \text{ V}$	Each Input	24
				1.0	mA	$V_{CC} = \text{MAX.}, V_{IN} = 5.5 \text{ V}$		
I_{IL}	Input LOW Current			-1.6	mA	$V_{CC} = \text{MAX.}, V_{IN} = 0.4 \text{ V}$, Each Input	23	
I_{OS}	Output Short Circuit Current (Note 3)	-20		-55	mA	$V_{CC} = \text{MAX.}$	25	
		-18		-55	mA			9N50/7450; 9N51/7451
I_{CCH}	Supply Current HIGH		4.0	8.0	mA	$V_{CC} = \text{MAX.}, V_{IN} = 0 \text{ V}$	26	
I_{CCL}	Supply Current LOW		7.4	14	mA	$V_{CC} = \text{MAX.}, V_{IN} = 5.0 \text{ V}$	27	

NOTES:

- (1) For conditions shown as MIN. or MAX., use the appropriate value specified under recommended operating conditions for the applicable device type. Expander inputs X and \bar{X} are open.
- (2) Typical limits are at $V_{CC} = 5.0 \text{ V}, 25^\circ\text{C}$.
- (3) Not more than one output should be shorted at a time.
- (4) Required at both input terminals of either AND section to ensure LOW level at output.
- (5) Required at one input terminal of each AND section to ensure HIGH level at output.

FAIRCHILD TTL/SSI • 9N50/5450, 7450 • 9N51/5451, 7451

ELECTRICAL CHARACTERISTICS (9N50/5450 CIRCUITS), Using Expander Inputs, $V_{CC} = 4.5\text{ V}$, $T_A = -55^\circ\text{C}$

SYMBOL	PARAMETER	LIMITS			UNITS	TEST CONDITIONS	TEST FIGURE
		MIN.	TYP.	MAX.			
I_X	Expander Current			2.9	mA	$V_1 = 0.4\text{ V}$, $I_{OL} = 16\text{ mA}$	28
$V_{BE(Q)}$	Base-Emitter Voltage of Output Transistor Q			1.0	Volts	$I_{OL} = 16\text{ mA}$, $I_1 = 0.41\text{ mA}$, $R_1 = 0\Omega$	29
V_{OH}	Output HIGH Voltage	2.4	3.3		Volts	$I_{OH} = -400\ \mu\text{A}$, $I_1 = 0.15\text{ mA}$, $I_2 = -0.15\text{ mA}$	30
V_{OL}	Output LOW Voltage		0.22	0.4	Volts	$I_{OL} = 16\text{ mA}$, $I_1 = 0.3\text{ mA}$, $R_1 = 138\Omega$	29

ELECTRICAL CHARACTERISTICS (9N50/7450 CIRCUITS), Using Expander Inputs, $V_{CC} = 4.75\text{ V}$, $T_A = 0^\circ\text{C}$

SYMBOL	PARAMETER	LIMITS			UNITS	TEST CONDITIONS	TEST FIGURE
		MIN.	TYP.	MAX.			
I_X	Expander Current			3.1	mA	$V_1 = 0.4\text{ V}$, $I_{OL} = 16\text{ mA}$	28
$V_{BE(Q)}$	Base-Emitter Voltage of Output Transistor Q			1.0	Volts	$I_{OL} = 16\text{ mA}$, $I_1 = 0.62\text{ mA}$, $R_1 = 0\Omega$	29
V_{OH}	Output HIGH Voltage	2.4	3.3		Volts	$I_{OH} = -400\ \mu\text{A}$, $I_1 = 270\ \mu\text{A}$, $I_2 = -270\ \mu\text{A}$	30
V_{OL}	Output LOW Voltage		0.22	0.4	Volts	$I_{OL} = 16\text{ mA}$, $I_1 = 0.43\text{ mA}$, $R_1 = 130\Omega$	29

SWITCHING CHARACTERISTICS ($T_A = 25^\circ\text{C}$)

SYMBOL	PARAMETER	LIMITS			UNITS	TEST CONDITIONS	TEST FIGURE
		MIN.	TYP.	MAX.			
t_{PLH}	Turn Off Delay Input to Output		13	22	ns	$V_{CC} = 5.0\text{ V}$ $C_L = 15\text{ pF}$ $R_L = 400\Omega$	A
t_{PHL}	Turn On Delay Input to Output		8.0	15	ns		

EXPANDABLE 2-2-2-3-INPUT AND-OR GATE

LOGIC AND CONNECTION DIAGRAM

DIP (TOP VIEW)

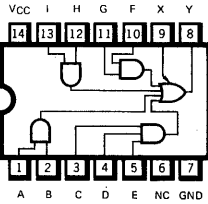

FLATPAK (TOP VIEW)

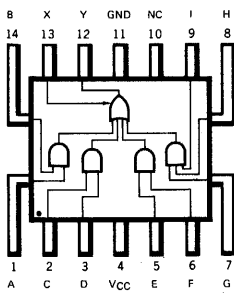

SCHEMATIC DIAGRAM

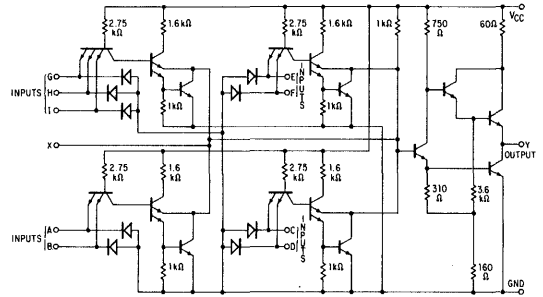

Positive logic:

Positive logic:

$$Y = (AB) + (CDE) + (FG) + (HI) + (X) \quad Y = (AB) + (CD) + (EF) + (GHI) + (X)$$

(X = Output of 9H61/54H61, 74H61)

NOTES:

- (a) Component values shown are typical.
- (b) A total of six expander gates may be connected to the expander input X.
- (c) NC — No internal connection.

RECOMMENDED OPERATING CONDITIONS

PARAMETER	9H52XM/54H52XM			9H52XC/74H52XC			UNITS
	MIN.	TYP.	MAX.	MIN.	TYP.	MAX.	
Supply Voltage V_{CC}	4.5	5.0	5.5	4.75	5.0	5.25	Volts
Operating Free-Air Temperature Range	-55	25	125	0	25	70	$^{\circ}C$
Input Loading for Each Input			1.25			1.25	U.L.

X = package type; F for Flatpak, D for Ceramic Dip, P for Plastic Dip. See Packaging Information Section for packages available on this product.

ELECTRICAL CHARACTERISTICS OVER OPERATING TEMPERATURE RANGE (Unless Otherwise Noted)

SYMBOL	PARAMETER	LIMITS			UNITS	TEST CONDITIONS (Note 1)	TEST FIGURE	
		MIN.	TYP. (Note 2)	MAX.				
V_{IH}	Input HIGH Voltage (Note 4)	2.0			Volts	Guaranteed Input HIGH Voltage	105	
V_{IL}	Input LOW Voltage (Note 5)			0.8	Volts	Guaranteed Input LOW Voltage	106	
V_{OH}	Output HIGH Voltage	2.4			Volts	$V_{CC} = \text{MIN.}, I_{OH} = -0.5 \text{ mA}, V_{IN} = 2.0 \text{ V}$	105	
V_{OL}	Output LOW Voltage			0.4	Volts	$V_{CC} = \text{MIN.}, I_{OL} = 20 \text{ mA}, V_{IN} = 0.8 \text{ V}$	106	
I_{IH}	Input HIGH Current			50	μA	$V_{CC} = \text{MAX.}, V_{IN} = 2.4 \text{ V}$ $V_{CC} = \text{MAX.}, V_{IN} = 5.5 \text{ V}$	Each Input	108
				1.0	mA			
I_{IL}	Input LOW Current			-2.0	mA	$V_{CC} = \text{MAX.}, V_{IN} = 0.4 \text{ V}$, Each Input	107	
I_{OS}	Output Short Circuit Current (Note 3)	-40		-100	mA	$V_{CC} = \text{MAX.}, V_{IN} = 4.5 \text{ V}$	109	
I_{CCH}	Supply Current HIGH		20	31	mA	$V_{CC} = \text{MAX.}, V_{IN} = 4.5 \text{ V}$	110	
I_{CCL}	Supply Current LOW		15.2	24	mA	$V_{CC} = \text{MAX.}, V_{IN} = 0 \text{ V}$	110	

NOTES:

- (1) For conditions shown as MIN. or MAX., use the appropriate value specified under recommended operating conditions for the applicable device type. Expander pin is open.
- (2) Typical limits are at $V_{CC} = 5.0 \text{ V}, 25^{\circ}C$.
- (3) Duration of short-circuit test should not exceed 1 second.
- (4) Required at all input terminals of one AND section to ensure HIGH level at output.
- (5) Required at one input terminal of each AND section to ensure LOW level at output.

FAIRCHILD HIGH SPEED TTL/SSI • 9H52/54H52, 74H52

ELECTRICAL CHARACTERISTICS (9H52/54H52 Circuits Only) Using Expander Inputs, $V_{CC} = 4.5\text{ V}$

SYMBOL	PARAMETER	LIMITS			UNITS	TEST CONDITIONS	TEST FIGURE
		MIN.	TYP.	MAX.			
I_{INX}	Expander-Node Input Current	-2.7		-4.5	mA	$V_X = 1.0\text{ V}, I_{OH} = -500\ \mu\text{A}, T_A = -55^\circ\text{C}$	111
V_{OH}	Output HIGH Voltage	2.4			Volts		
V_{OL}	Output LOW Voltage			0.4	Volts	$I_{INX} = -300\ \mu\text{A}, I_{OL} = 20\ \text{mA}, T_A = 125^\circ\text{C}$	112

ELECTRICAL CHARACTERISTICS (9H52/74H52 Circuits Only) Using Expander Inputs, $V_{CC} = 4.75\text{ V}$

SYMBOL	PARAMETER	LIMITS			UNITS	TEST CONDITIONS	TEST FIGURE
		MIN.	TYP.	MAX.			
I_{INX}	Expander-Node Input Current	-2.9		-5.35	mA	$V_X = 1.0\text{ V}, I_{OH} = -500\ \mu\text{A}, T_A = 0^\circ\text{C}$	111
V_{OH}	Output HIGH Voltage	2.4			Volts		
V_{OL}	Output LOW Voltage			0.4	Volts	$I_{INX} = -300\ \mu\text{A}, I_{OL} = 20\ \text{mA}, T_A = 70^\circ\text{C}$	112

SWITCHING CHARACTERISTICS, Expander Pin is Open ($T_A = 25^\circ\text{C}$)

SYMBOL	PARAMETER	LIMITS			UNITS	TEST CONDITIONS	TEST FIGURE
		MIN.	TYP.	MAX.			
tPLH	Turn Off Delay Input to Output		10.6	15	ns	$V_{CC} = 5.0\text{ V}$ $C_L = 25\ \text{pF}$ $R_L = 280\ \Omega$	T
tPHL	Turn On Delay Input to Output		9.2	15	ns		

SWITCHING CHARACTERISTICS ($T_A = 25^\circ\text{C}$)

SYMBOL	PARAMETER	LIMITS			UNITS	TEST CONDITIONS	TEST FIGURE
		MIN.	TYP.	MAX.			
tPLH	Turn Off Delay Input to Output		14.8		ns	$V_{CC} = 5.0\text{ V}$ $C_L = 25\ \text{pF}$ $R_L = 280\ \Omega$ $*C_X = 15\ \text{pF}$	V *MM & NN
tPHL	Turn On Delay Input to Output		9.8		ns		

5

EXPANDABLE 2-2-2-3 INPUT AND-OR-INVERT GATE

LOGIC AND CONNECTION DIAGRAM

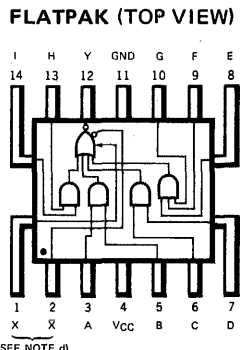
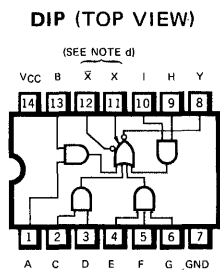

SCHEMATIC DIAGRAM

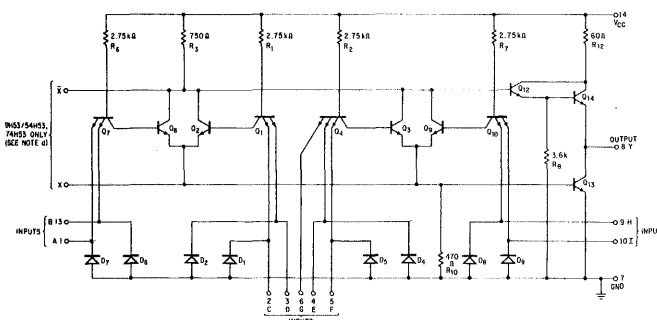

Positive logic: $Y = \overline{(AB) + (CD) + (EFG) + (HI)E(X)}$
 (X = Output of 9H60/54H60, 74H60 or 9H62/54H62, 74H62)

NOTES:

- (a) Component values shown are typical.
- (b) Both expander inputs are used simultaneously for expanding.
- (c) If expander is not used leave X and \bar{X} pins open.
- (d) Expander inputs X and \bar{X} are functional on the 9H53/54H53, 74H53 circuits only. Make no external connection to X and \bar{X} pins of the 9H54/54H54, 74H54.
- (e) A total of four 9H60/54H60, 74H60 expander gates or one 9H62/54H62, 74H62 expander gate may be connected to the expander inputs.

RECOMMENDED OPERATING CONDITIONS

PARAMETER	9H53XM/54H53XM 9H54XM/54H54XM			9H53XC/74H53XC 9H54XC/74H54XC			UNITS
	MIN.	TYP.	MAX.	MIN.	TYP.	MAX.	
Supply Voltage V_{CC}	4.5	5.0	5.5	4.75	5.0	5.25	Volts
Operating Free-Air Temperature Range	-55	25	125	0	25	70	$^{\circ}C$
Input Loading for Each Input			1.25			1.25	U.L.

X = package type; F for Flatpak, D for Ceramic Dip, P for Plastic Dip. See Packaging Information Section for packages available on this product.

ELECTRICAL CHARACTERISTICS OVER OPERATING TEMPERATURE RANGE (Unless Otherwise Noted)

SYMBOL	PARAMETER	LIMITS			UNITS	TEST CONDITIONS (Note 1)	TEST FIGURE	
		MIN.	TYP. (Note 2)	MAX.				
V_{IH}	Input HIGH Voltage (Note 4)	2.0			Volts	Guaranteed Input HIGH Voltage	21	
V_{IL}	Input LOW Voltage (Note 5)			0.8	Volts	Guaranteed Input LOW Voltage	22	
V_{OH}	Output HIGH Voltage	2.4			Volts	$V_{CC} = \text{MIN.}, I_{OH} = -0.5 \text{ mA}, V_{IN} = 0.8 \text{ V}$	22	
V_{OL}	Output LOW Voltage			0.4	Volts	$V_{CC} = \text{MIN.}, I_{OL} = 20 \text{ mA}, V_{IN} = 2.0 \text{ V}$	21	
I_{IH}	Input HIGH Current			50	μA	$V_{CC} = \text{MAX.}, V_{IN} = 2.4 \text{ V}$ $V_{CC} = \text{MAX.}, V_{IN} = 5.5 \text{ V}$	Each Input	24
I_{IL}				1.0	mA			
I_{IL}	Input LOW Current			-2.0	mA	$V_{CC} = \text{MAX.}, V_{IN} = 0.4 \text{ V}$, Each Input	23	
I_{OS}	Output Short Circuit Current (Note 3)	-40		-100	mA	$V_{CC} = \text{MAX.}$	25	
I_{CCH}	Supply Current HIGH		7.1	11	mA	$V_{CC} = \text{MAX.}, V_{IN} = 0 \text{ V}$	27	
I_{CCL}	Supply Current LOW		9.4	14	mA	$V_{CC} = \text{MAX.}, V_{IN} = 4.5 \text{ V}$	26	

NOTES:

- (1) For conditions shown as MIN. or MAX., use the appropriate value specified under recommended operating conditions for the applicable device type. Expander pins are open.
- (2) Typical limits are at $V_{CC} = 5.0 \text{ V}, 25^{\circ}C$.
- (3) Duration of short-circuit test should not exceed 1 second.
- (4) Required at all input terminals of one AND section to ensure LOW level at output.
- (5) Required at one input terminal of each AND section to ensure HIGH level at output.

FAIRCHILD HIGH SPEED TTL/SSI • 9H53/54H53, 74H53 • 9H54/54H54, 74H54

ELECTRICAL CHARACTERISTICS (9H53/54H53 Circuits Only) Using Expander Inputs, $V_{CC} = 4.5\text{ V}$, $T_A = -55^\circ\text{C}$

SYMBOL	PARAMETER	LIMITS			UNITS	TEST CONDITIONS	TEST FIGURE
		MIN.	TYP.	MAX.			
$I_{IN\bar{X}}$	Expander-Node Input Current			-5.85	mA	$V_{\bar{X}} = 1.4\text{ V}$	104
$V_{BE(Q)}$	Base-Emitter Voltage of Output Transistor Q			1.0	Volts	$I_{OL} = 20\text{ mA}$, $I_1 = 700\text{ }\mu\text{A}$, $R_1 = 0\Omega$	29
V_{OH}	Output HIGH Voltage	2.4			Volts	$I_{OH} = -500\text{ }\mu\text{A}$, $I_1 = 320\text{ }\mu\text{A}$, $I_2 = -320\text{ }\mu\text{A}$	30
V_{OL}	Output LOW Voltage			0.4	Volts	$I_{OL} = 20\text{ mA}$, $I_1 = 470\text{ }\mu\text{A}$, $R_1 = 68\Omega$	29

ELECTRICAL CHARACTERISTICS (9H53/74H53 Circuits Only) Using Expander Inputs, $V_{CC} = 4.75\text{ V}$, $T_A = 0^\circ\text{C}$

SYMBOL	PARAMETER	LIMITS			UNITS	TEST CONDITIONS	TEST FIGURE
		MIN.	TYP.	MAX.			
$I_{IN\bar{X}}$	Expander-Node Input Current			-6.3	mA	$V_{\bar{X}} = 1.4\text{ V}$	104
$V_{BE(Q)}$	Base-Emitter Voltage of Output Transistor Q			1.0	Volts	$I_{OL} = 20\text{ mA}$, $I_1 = 1.1\text{ mA}$, $R_1 = 0\Omega$	29
V_{OH}	Output HIGH Voltage	2.4			Volts	$I_{OH} = -500\text{ }\mu\text{A}$, $I_1 = 570\text{ }\mu\text{A}$, $I_2 = -570\text{ }\mu\text{A}$	30
V_{OL}	Output LOW Voltage			0.4	Volts	$I_{OL} = 20\text{ mA}$, $I_1 = 600\text{ }\mu\text{A}$, $R_1 = 63\Omega$	29

SWITCHING CHARACTERISTICS, Expander Pins are Open ($T_A = 25^\circ\text{C}$)

SYMBOL	PARAMETER	LIMITS			UNITS	TEST CONDITIONS	TEST FIGURE
		MIN.	TYP.	MAX.			
t_{PLH}	Turn Off Delay Input to Output		7.0	11	ns	$V_{CC} = 5.0\text{ V}$ $C_L = 25\text{ pF}$ $R_L = 280\Omega$	T
t_{PHL}	Turn On Delay Input to Output		6.2	11	ns		

SWITCHING CHARACTERISTICS (9H53/54H53, 74H53 Circuits Only) ($T_A = 25^\circ\text{C}$)

SYMBOL	PARAMETER	LIMITS			UNITS	TEST CONDITIONS	TEST FIGURE
		MIN.	TYP.	MAX.			
t_{PLH}	Turn Off Delay Input to Output		11.4			$V_{CC} = 5.0\text{ V}$ $C_L = 25\text{ pF}$ $R_L = 280\Omega$ $*C_X = 15\text{ pF}$	U *MM & NN
t_{PHL}	Turn On Delay Input to Output		7.4				

EXPANDABLE 4-WIDE 2-INPUT AND-OR-INVERT GATE

LOGIC AND CONNECTION DIAGRAM

SCHEMATIC DIAGRAM

DIP (TOP VIEW)

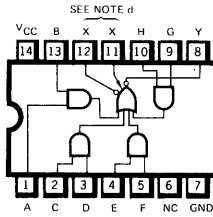

FLATPAK (TOP VIEW)

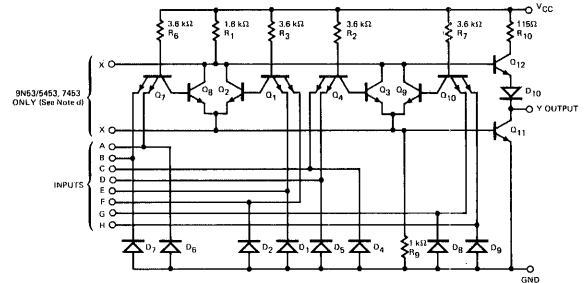
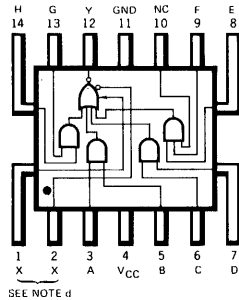

Positive logic: $Y = (AB) + (CD) + (EF) + (GH) + (X)$
 (X = Output of 9N60/5460, 7460)

NOTES:

- (a) Component values shown are typical.
- (b) Both expander inputs are used simultaneously for expanding.
- (c) If expander is not used leave X and \bar{X} pins open.
- (d) Make no external connection to X and \bar{X} pins of the 9N54/5454, 7454.
- (e) A total of four expander gates can be connected to the expander inputs.
- (f) NC - No internal connection.

RECOMMENDED OPERATING CONDITIONS

PARAMETER	9N53XM/5453XM 9N54XM/5454XM			9N53XC/7453XC 9N54XC/7454XC			UNITS
	MIN.	TYP.	MAX.	MIN.	TYP.	MAX.	
Supply Voltage V_{CC}	4.5	5.0	5.5	4.75	5.0	5.25	Volts
Operating Free-Air Temperature Range	-55	25	125	0	25	70	°C
Normalized Fan-Out from Each Output, N			10			10	U.L.

X = package type; F for Flatpak, D for Ceramic Dip, P for Plastic Dip. See Packaging Information Section for packages available on this product.

ELECTRICAL CHARACTERISTICS OVER OPERATING TEMPERATURE RANGE (Unless Otherwise Noted)

SYMBOL	PARAMETER	LIMITS			UNITS	TEST CONDITIONS (Note 1)	TEST FIGURE
		MIN.	TYP. (Note 2)	MAX.			
V_{IH}	Input HIGH Voltage (Note 4)	2.0			Volts	Guaranteed Input HIGH Voltage	21
V_{IL}	Input LOW Voltage (Note 5)			0.8	Volts	Guaranteed Input LOW Voltage	22
V_{OH}	Output HIGH Voltage	2.4	3.3		Volts	$V_{CC} = \text{MIN.}, I_{OH} = -0.4 \text{ mA}, V_{IN} = 0.8 \text{ V}$	22
V_{OL}	Output LOW Voltage		0.22	0.4	Volts	$V_{CC} = \text{MIN.}, I_{OL} = 16 \text{ mA}, V_{IN} = 2.0 \text{ V}$	21
I_{IH}	Input HIGH Current			40	μA	$V_{CC} = \text{MAX.}, V_{IN} = 2.4 \text{ V}$	Each Input 24
I_{IL}	Input LOW Current			1.0	mA	$V_{CC} = \text{MAX.}, V_{IN} = 5.5 \text{ V}$	
I_{OS}	Output Short Circuit Current (Note 3)			-55	mA	$V_{CC} = \text{MAX.}, V_{IN} = 0.4 \text{ V}, \text{ Each Input}$	25
		-20		-55	mA	$V_{CC} = \text{MAX.}$	
I_{CCH}	Supply Current HIGH		4.0	8.0	mA	$V_{CC} = \text{MAX.}, V_{IN} = 0 \text{ V}$	26
I_{CCL}	Supply Current LOW		5.1	9.5	mA	$V_{CC} = \text{MAX.}, V_{IN} = 5.0 \text{ V}$	27

NOTES:

- (1) For conditions shown as MIN. or MAX., use the appropriate value specified under recommended operating conditions for the applicable device type. Expander inputs X and \bar{X} are open.
- (2) Typical limits are at $V_{CC} = 5.0 \text{ V}, 25^\circ\text{C}$.
- (3) Not more than one output should be shorted at a time.
- (4) Required at both input terminals of one AND section to ensure LOW level at output.
- (5) Required at one input terminal of each AND section to ensure HIGH level at output.

FAIRCHILD TTL/SSI • 9N53/5453, 7453 • 9N54/5454, 7454

ELECTRICAL CHARACTERISTICS 9N53/5453 CIRCUITS, Using Expander Inputs, $V_{CC} = 4.5\text{ V}$, $T_A = 55^\circ\text{C}$

SYMBOL	PARAMETER	LIMITS			UNITS	TEST CONDITIONS	TEST FIGURE
		MIN.	TYP.	MAX.			
I_X	Expander Current			2.9	mA	$V_1 = 0.4\text{ V}$, $I_{OL} = 16\text{ mA}$	28
$V_{BE(Q)}$	Base-Emitter Voltage of Output Transistor Q			1.0	Volts	$I_{OL} = 16\text{ mA}$, $I_1 = 0.41\text{ mA}$, $R_1 = 0\Omega$	29
V_{OH}	Output HIGH Voltage	2.4	3.3		Volts	$I_{OH} = -400\ \mu\text{A}$, $I_1 = 0.15\text{ mA}$, $I_2 = -0.15\text{ mA}$	30
V_{OL}	Output LOW Voltage		0.22	0.4	Volts	$I_{OL} = 16\text{ mA}$, $I_1 = 0.3\text{ mA}$, $R_1 = 138\Omega$	29

ELECTRICAL CHARACTERISTICS 9N53/7453 CIRCUITS, Using Expander Inputs, $V_{CC} = 4.75\text{ V}$, $T_A = 0^\circ\text{C}$

SYMBOL	PARAMETER	LIMITS			UNITS	TEST CONDITIONS	TEST FIGURE
		MIN.	TYP.	MAX.			
I_X	Expander Current			3.1	mA	$V_1 = 0.4\text{ V}$, $I_{OL} = 16\text{ mA}$	28
$V_{BE(Q)}$	Base-Emitter Voltage of Output Transistor Q			1.0	Volts	$I_{OL} = 16\text{ mA}$, $I_1 = 0.62\text{ mA}$, $R_1 = 0\Omega$	29
V_{OH}	Output HIGH Voltage	2.4	3.3		Volts	$I_{OH} = -400\ \mu\text{A}$, $I_1 = 270\ \mu\text{A}$, $I_2 = -270\ \mu\text{A}$	30
V_{OL}	Output LOW Voltage		0.22	0.4	Volts	$I_{OL} = 16\text{ mA}$, $I_1 = 0.43\text{ mA}$, $R_1 = 130\Omega$	29

SWITCHING CHARACTERISTICS ($T_A = 25^\circ\text{C}$)

SYMBOL	PARAMETER	LIMITS			UNITS	TEST CONDITIONS	TEST FIGURE
		MIN.	TYP.	MAX.			
t_{PLH}	Turn Off Delay Input to Output		13	22	ns	$V_{CC} = 5.0\text{ V}$ $C_L = 15\text{ pF}$ $R_L = 400\Omega$	A
t_{PHL}	Turn On Delay Input to Output		8.0	15	ns		

5

LPTTL/SSI 9L54

LOW POWER AND-OR-INVERT GATE

DESCRIPTION — The Low Power TTL/SSI 9L54 is a four wide, 2-2-2-3-input AND-OR-INVERT Gate. It is designed for low power and medium speed operation.

- TYPICAL POWER DISSIPATION OF 10 mW
- TYPICAL DELAY OF 25 ns
- INPUT CLAMP DIODES LIMIT HIGH SPEED TERMINATION EFFECTS
- HIGH CAPACITIVE DRIVE CAPABILITY
- TTL COMPATIBLE
- ALL CERAMIC "HERMETIC" PACKAGES

PIN NAMES

INPUTS (Pins 1, 2, 3, 4, 5, 6, 9, 10, 13)
OUTPUT (Pin 8)

1 Unit Load (U.L.) = 40 μ A HIGH/1.6 mA LOW.

LOADING	
HIGH	LOW
0.75 U.L.	0.38 U.L.
10 U.L.	2.5 U.L.

SCHEMATIC DIAGRAM

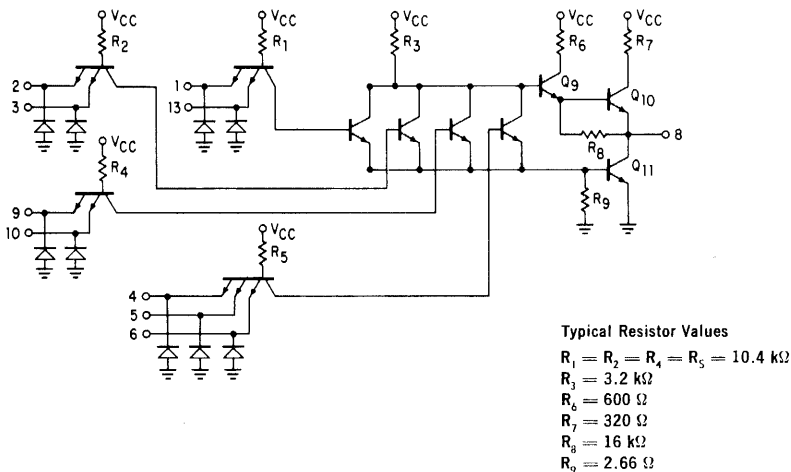

LOGIC SYMBOL

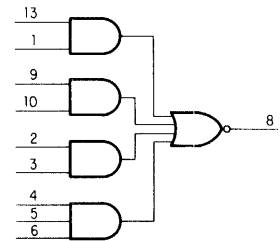

V_{CC} = Pin 14
Gnd = Pin 7

CONNECTION DIAGRAMS DIP (TOP VIEW)

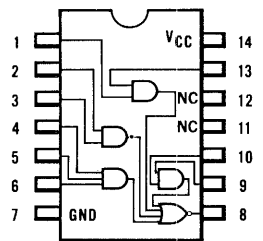

FLATPAK (TOP VIEW)

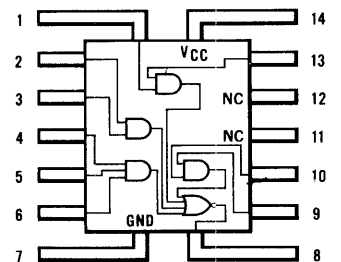

NC = No Internal Connection

FAIRCHILD LPTTL/SSI • 9L54

ABSOLUTE MAXIMUM RATINGS (above which the useful life may be impaired)

Storage Temperature	-65°C to +150°C
Temperature (Ambient) Under Bias	-55°C to +125°C
V _{CC} Pin Potential to Ground Pin	-0.5 V to +7.0 V
*Input Voltage (dc)	-0.5 V to +5.5 V
*Input Current (dc)	-30 mA to +5.0 mA
Voltage Applied to Outputs (Output HIGH)	-0.5 V to +V _{CC} value
Output Current (dc) (Output LOW)	+30 mA

*Either Input Voltage limit or Input Current limit is sufficient to protect the inputs.

GUARANTEED OPERATING RANGES

PART NUMBER	SUPPLY VOLTAGE (V _{CC})			TEMPERATURE
	MIN.	TYP.	MAX.	
9L54XM	4.5V	5.0V	5.5V	-55°C to 125°C
9L54XC	4.75V	5.0V	5.25V	0°C to 75°C

X = package type; F for Flatpak, D for Ceramic Dip, P for Plastic Dip. See Packaging Information Section for packages available on this product.

ELECTRICAL CHARACTERISTICS OVER OPERATING TEMPERATURE RANGE (Unless Otherwise Noted) (See Notes 1 & 2)

SYMBOL	PARAMETER	LIMITS			UNITS	CONDITIONS
		MIN.	TYP. (Note 3)	MAX.		
V _{OH}	Output HIGH Voltage	2.4	3.3		Volts	V _{CC} = MIN., I _{OH} = -0.4 mA, V _{IN} = V _{IL}
V _{OL}	Output LOW Voltage		0.1	0.3	Volts	V _{CC} = MIN., I _{OL} = 4.0 mA, V _{IN} = V _{IH}
V _{IH}	Input HIGH Voltage	2.0			Volts	Guaranteed input logical HIGH voltage for all inputs
V _{IL}	Input LOW Voltage			0.7	Volts	Guaranteed input logical LOW voltage for all inputs
I _{IL}	Input LOW Current		-0.38	-0.6	mA	V _{CC} = MAX., V _{IN} = 0.3 V
I _{IH}	Input HIGH Current		3.0	30	μA	V _{CC} = MAX., V _{IN} = 2.4 V
				1.0	mA	V _{CC} = MAX., V _{IN} = 5.5 V
I _{SC} (Note 4)	Output Short Circuit Current	-10	-22	-40	mA	V _{CC} = MAX., V _{OUT} = 0.0 V Inputs grounded.
I _{CC}	Power Supply Current		2.6	3.7	mA	V _{CC} = MAX., Inputs HIGH
			1.6	2.7	mA	V _{CC} = MAX., Inputs LOW
t _{PLH}	Turn Off Delay		28		ns	V _{CC} = 5.0 V, See Fig. 1
t _{PHL}	Turn On Delay		22		ns	C _L = 15 pF

NOTES:

- (1) Conditions for testing, not shown in the Table, are chosen to guarantee operation under "worst case" conditions.
- (2) The specified LIMITS represent the "worst case" value for the parameter. Since these "worst case" values normally occur at the temperature and supply voltage extremes, additional noise immunity and guard banding can be achieved by decreasing the allowable system operating ranges.
- (3) Typical limits are at V_{CC} = 5.0V, 25°C, and max. loading.
- (4) Not more than one output should be shorted at a time.

Fig. 1 SWITCHING TIME WAVEFORM

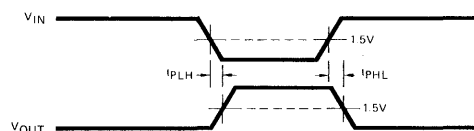

EXPANDABLE 4-INPUT AND-OR-INVERT GATE

LOGIC AND CONNECTION DIAGRAM

DIP (TOP VIEW)

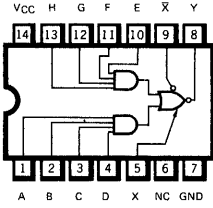

FLATPAK (TOP VIEW)

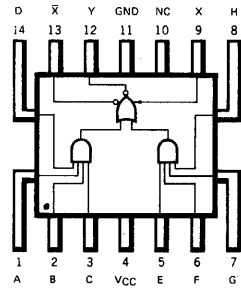

SCHEMATIC DIAGRAM

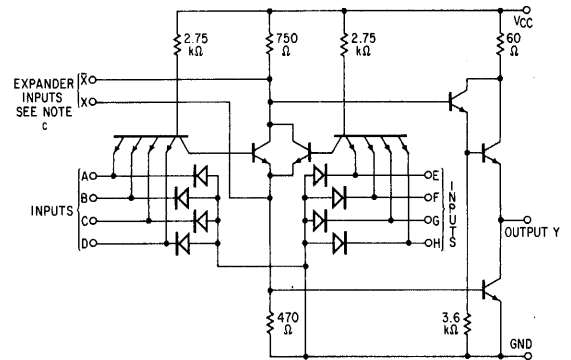

Positive logic: $Y = (ABCD) + (EFGH) + (X)$
 $X = \text{Output of 9H60/54H60, 74H60 or 9H62/54H62, 74H62.}$

NOTES:

- (a) Component values shown are typical.
- (b) Both expander inputs are used simultaneously for expanding.
- (c) If expander is not used leave X and \bar{X} pins open.
- (d) A total of four 9H60/54H60, 74H60 expander gates or one 9H62/54H62, 74H62 expander gate may be connected to the expander inputs.
- (e) NC — No internal connection.

RECOMMENDED OPERATING CONDITIONS

PARAMETER	9H55XM/54H55XM			9H55XC/74H55XC			UNITS
	MIN.	TYP.	MAX.	MIN.	TYP.	MAX.	
Supply Voltage V_{CC}	4.5	5.0	5.5	4.75	5.0	5.25	Volts
Operating Free-Air Temperature Range	-55	25	125	0	25	70	°C
Input Loading for Each Input			1.25			1.25	U.L.

X = package type; F for Flatpak, D for Ceramic Dip, P for Plastic Dip. See Packaging Information Section for packages available on this product.

ELECTRICAL CHARACTERISTICS OVER OPERATING TEMPERATURE RANGE (Unless Otherwise Noted)

SYMBOL	PARAMETER	LIMITS			UNITS	TEST CONDITIONS (Note 1)	TEST FIGURE
		MIN.	TYP. (Note 2)	MAX.			
V_{IH}	Input HIGH Voltage (Note 4)	2.0			Volts	Guaranteed Input HIGH Voltage	21
V_{IL}	Input LOW Voltage (Note 5)			0.8	Volts	Guaranteed Input LOW Voltage	22
V_{OH}	Output HIGH Voltage	2.4			Volts	$V_{CC} = \text{MIN.}, I_{OH} = -0.5 \text{ mA}, V_{IN} = 0.8 \text{ V}$	22
V_{OL}	Output LOW Voltage			0.4	Volts	$V_{CC} = \text{MIN.}, I_{OL} = 20 \text{ mA}, V_{IN} = 2.0 \text{ V}$	21
I_{IH}	Input HIGH Current			50	μA	$V_{CC} = \text{MAX.}, V_{IN} = 2.4 \text{ V}$ $V_{CC} = \text{MAX.}, V_{IN} = 5.5 \text{ V}$	Each Input
				1.0	mA		
I_{IL}	Input LOW Current			-2.0	mA	$V_{CC} = \text{MAX.}, V_{IN} = 0.4 \text{ V}$, Each Input	23
I_{OS}	Output Short Circuit Current (Note 3)	-40		-100	mA	$V_{CC} = \text{MAX.}$	25
I_{CCH}	Supply Current HIGH		4.5	6.4	mA	$V_{CC} = \text{MAX.}, V_{IN} = 0 \text{ V}$	27
I_{CCL}	Supply Current LOW		7.5	12	mA	$V_{CC} = \text{MAX.}, V_{IN} = 4.5 \text{ V}$	26

NOTES:

- (1) For conditions shown as MIN. or MAX., use the appropriate value specified under recommended operating conditions for the applicable device type. Expander pins are open.
- (2) Typical limits are at $V_{CC} = 5.0 \text{ V}, 25^\circ\text{C}$.
- (3) Duration of short-circuit test should not exceed 1 second.
- (4) Required at all input terminals of either AND section to ensure LOW level at output.
- (5) Required at one input terminal of each AND section to ensure HIGH level at output.

FAIRCHILD HIGH SPEED TTL/SSI • 9H55/54H55, 74H55

ELECTRICAL CHARACTERISTICS (9H55/54H55 Circuits Only) Using Expander Inputs, $V_{CC} = 4.5\text{ V}$, $T_A = -55^\circ\text{C}$

SYMBOL	PARAMETER	LIMITS			UNITS	TEST CONDITIONS	TEST FIGURE
		MIN.	TYP.	MAX.			
$I_{IN\bar{X}}$	Expander-Node Input Current			-5.85	mA	$V_{\bar{X}} = 1.4\text{ V}$	104
$V_{BE(Q)}$	Base-Emitter Voltage of Output Transistor Q			1.0	Volts	$I_{OL} = 20\text{ mA}$, $I_1 = 700\ \mu\text{A}$, $R_1 = 0\ \Omega$	29
V_{OH}	Output HIGH Voltage	2.4			Volts	$I_{OH} = -500\ \mu\text{A}$, $I_1 = 320\ \mu\text{A}$, $I_2 = -320\ \mu\text{A}$	30
V_{OL}	Output LOW Voltage			0.4	Volts	$I_{OL} = 20\text{ mA}$, $I_1 = 470\ \mu\text{A}$, $R_1 = 68\ \Omega$	29

ELECTRICAL CHARACTERISTICS (9H55/74H55 Circuits Only) Using Expander Inputs, $V_{CC} = 4.75\text{ V}$, $T_A = 0^\circ\text{C}$

SYMBOL	PARAMETER	LIMITS			UNITS	TEST CONDITIONS	TEST FIGURE
		MIN.	TYP.	MAX.			
$I_{IN\bar{X}}$	Expander-Node Input Current			-6.3	mA	$V_{\bar{X}} = 1.4\text{ V}$	104
$V_{BE(Q)}$	Base-Emitter Voltage of Output Transistor Q			1.0	Volts	$I_{OL} = 20\text{ mA}$, $I_1 = 1.1\text{ mA}$, $R_1 = 0\ \Omega$	29
V_{OH}	Output HIGH Voltage	2.4			Volts	$I_{OH} = -500\ \mu\text{A}$, $I_1 = 570\ \mu\text{A}$, $I_2 = -570\ \mu\text{A}$	30
V_{OL}	Output LOW Voltage			0.4	Volts	$I_{OL} = 20\text{ mA}$, $I_1 = 600\ \mu\text{A}$, $R_1 = 63\ \Omega$	29

SWITCHING CHARACTERISTICS, Expander Pins are Open ($T_A = 25^\circ\text{C}$)

SYMBOL	PARAMETER	LIMITS			UNITS	TEST CONDITIONS	TEST FIGURE
		MIN.	TYP.	MAX.			
t_{PLH}	Turn Off Delay Input to Output		7.0	11	ns	$V_{CC} = 5.0\text{ V}$ $C_L = 25\text{ pF}$ $R_L = 280\ \Omega$	T
t_{PHL}	Turn On Delay Input to Output		6.5	11	ns		

SWITCHING CHARACTERISTICS ($T_A = 25^\circ\text{C}$)

SYMBOL	PARAMETER	LIMITS			UNITS	TEST CONDITIONS	TEST FIGURE
		MIN.	TYP.	MAX.			
t_{PLH}	Turn Off Delay Input to Output		11.4		ns	$V_{CC} = 5.0\text{ V}$ $C_L = 25\text{ pF}$ $R_L = 280\ \Omega$ $*C_X = 15\text{ pF}$	U *MM & NN
t_{PHL}	Turn On Delay Input to Output		7.7		ns		

5

DUAL 4-INPUT EXPANDER

LOGIC AND CONNECTION DIAGRAM

DIP (TOP VIEW)

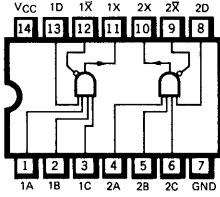

FLATPAK (TOP VIEW)

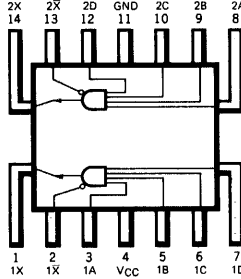

Positive logic: X = ABCD when connected to X and X pins of 9H50/54H50, 74H50; 9H53/54H53, 74H53 or 9H55/54H55, 74H55 circuit.

SCHEMATIC DIAGRAM (EACH EXPANDER)

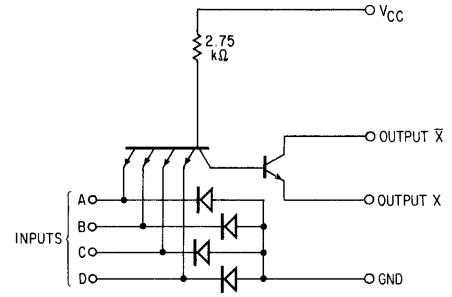

Component values shown are typical.

RECOMMENDED OPERATING CONDITIONS

PARAMETER	9H60XM/54H60XM			9H60XC/74H60XC			UNITS
	MIN.	TYP.	MAX.	MIN.	TYP.	MAX.	
Supply Voltage V _{CC}	4.5	5.0	5.5	4.75	5.0	5.25	Volts
Operating Free-Air Temperature Range	-55	25	125	0	25	70	°C
Maximum number of expanders that may be fanned in to one expandable AND OR Invert Gate			4			4	

X = package type; F for Flatpak, D for Ceramic Dip, P for Plastic Dip. See Packaging Information Section for packages available on this product.

ELECTRICAL CHARACTERISTICS OVER OPERATING TEMPERATURE RANGE (Unless Otherwise Noted)

SYMBOL	PARAMETER	LIMITS			UNITS	TEST CONDITIONS (Note 1)	TEST FIGURE
		MIN.	TYP. (Note 2)	MAX.			
V _{IH}	Input HIGH Voltage	2.0			Volts	(Note 3)	31
V _{IL}	Input LOW Voltage			0.8	Volts	(Note 4)	32
V _{ON}	On-State Output Voltage			0.4	Volts	V _{CC} = MIN., V _{IN} = 2.0 V, V _I = 1.0 V T _A = -55°C, I _{ON} = 5.85 mA T _A = 0°C, I _{ON} = 6.3 mA	31
				0.4	Volts	V _{CC} = MAX., V _{IN} = 2.0 V, V _I = 0.6 V T _A = 125°C, I _{ON} = 7.85 mA T _A = 70°C, I _{ON} = 7.4 mA	
I _{OFF}	Off-State Output Current			320	μA	T _A = -55°C	32
				570	μA	T _A = 0°C	
I _{ON}	On-State Output Current	-470			μA	T _A = -55°C	33
		-600			μA	T _A = 0°C	
I _{IH}	Input HIGH Current			50	μA	V _{CC} = MAX., V _{IN} = 2.4 V	Each Input 34
				1.0	mA	V _{CC} = MAX., V _{IN} = 5.5 V	
I _{IL}	Input LOW Current			-2.0	mA	V _{CC} = MAX., V _{IN} = 0.4 V, Each Input	32
I _{CC(ON)}	On-State Supply Current		1.9	3.5	mA	V _{CC} = MAX., V _{IN} = 4.5 V, V _I = 0.85 V	35
I _{CC(OFF)}	Off-State Supply Current		3.0	4.5	mA	V _{CC} = MAX., V _{IN} = 0 V, V _I = 0.85 V	35

OUTPUT CAPACITANCE, V_{CC} AND GND TERMINALS OPEN (T_A = 25°C)

SYMBOL	PARAMETER	LIMITS			UNITS	TEST CONDITIONS	TEST FIGURE
		MIN.	TYP.	MAX.			
C _X	Effective Capacitance of Output Transistor Q ₁		1.3		pF	f = 1 MHz	BB

NOTES:

- (1) For conditions shown as MIN. or MAX., use the appropriate value specified under recommended operating conditions for the applicable device type.
- (2) Typical limits are at V_{CC} = 5.0 V, 25°C.
- (3) Required at all input terminals to ensure output is in the on state.
- (4) Required at any input terminal to ensure output is in the off state.

DUAL 4-INPUT EXPANDER

LOGIC AND CONNECTION DIAGRAM

DIP (TOP VIEW)

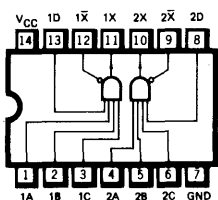

FLATPAK (TOP VIEW)

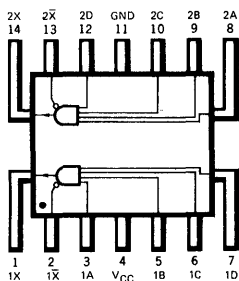

SCHEMATIC DIAGRAM (EACH EXPANDER)

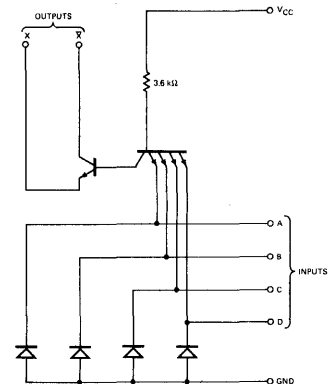

Component values shown are typical.

Positive logic: X = ABCD when connected to X and X-bar pins of 9N50/5450, 7450; 9N53/5453, 7453 circuit.

RECOMMENDED OPERATING CONDITIONS

PARAMETER	9N60XM/5460XM			9N60XC/7460XC			UNITS
	MIN.	TYP.	MAX.	MIN.	TYP.	MAX.	
Supply Voltage V _{CC}	4.5	5.0	5.5	4.75	5.0	5.25	Volts
Operating Free-Air Temperature Range	-55	25	125	0	25	70	°C
Maximum number of expanders that may be fanned-in to one expandable AND OR Invert Gate			4			4	

X = package type; F for Flatpak, D for Ceramic Dip, P for Plastic Dip. See Packaging Information Section for packages available on this product.

ELECTRICAL CHARACTERISTICS OVER OPERATING TEMPERATURE RANGE (Unless Otherwise Noted)

SYMBOL	PARAMETER	LIMITS			UNITS	TEST CONDITIONS (Note 1)	TEST FIGURE
		MIN.	TYP. (Note 2)	MAX.			
V _{IH}	Input HIGH Voltage	2.0			Volts	Guaranteed Input HIGH Voltage	31
V _{IL}	Input LOW Voltage			0.8	Volts	Guaranteed Input LOW Voltage	32
V _{ON}	On-State Output Voltage			0.4	Volts	V _{CC} = MIN., V _{IN} = 2.0 V V ₁ = 1.0 V, R = 1.1 kΩ T _A = -55°C T _A = 0°C	31
I _{OFF}	Off-State Output Current			150	μA	T _A = -55°C V _{CC} = MIN., V _{IN} = 0.8 V	32
				270	μA	T _A = 0°C V ₁ = 4.5 V, R = 1.2 kΩ	
I _{ON}	On-State Output Current	-0.3			mA	T _A = -55°C, V _{CC} = MIN., V _{IN} = 2.0 V, V ₁ = 1.0 V	33
		-0.43			mA	V _{CC} = 4.75 V, V _{IN} = 2.0 V, V ₁ = 1.0 V	
I _{IH}	Input HIGH Current			40	μA	V _{CC} = MAX., V _{IN} = 2.4 V	34
				1.0	mA	V _{CC} = MAX., V _{IN} = 5.5 V	
I _{IL}	Input LOW Current			-1.6	mA	V _{CC} = MAX., V _{IN} = 0.4 V, Each Input	32
I _{CC (on)}	On-State Supply Current		1.2	2.5	mA	V _{CC} = MAX., V _{IN} = 5.0 V, V ₁ = 0.85 V	35
I _{CC (off)}	Off-State Supply Current		2.0	4.0	mA	V _{CC} = MAX., V _{IN} = 0 V, V ₁ = 0.85 V	35

SWITCHING CHARACTERISTICS (T_A = 25°C)

SYMBOL	PARAMETER	LIMITS			UNITS	TEST CONDITIONS	TEST FIGURE
		MIN.	TYP.	MAX.			
t _{PLH}	*Turn Off Delay Input to Output		15	30	ns	V _{CC} = 5.0 V C _L = 15 pF	B
t _{PHL}	*Turn On Delay Input to Output		10	20	ns	R _L = 400Ω	

NOTES:

(1) For conditions shown as MIN. or MAX., use the appropriate value specified under recommended operating conditions for the applicable device type.

(2) Typical limits are at V_{CC} = 5.0 V, 25°C.

*Through 9N50/5450, 7450; 9N53/5453, 7453.



TRIPLE 3-INPUT EXPANDER

LOGIC AND CONNECTION DIAGRAM

DIP (TOP VIEW)

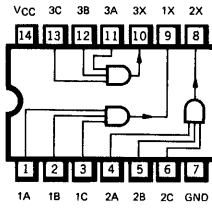

Positive logic: X = ABC

FLATPAK (TOP VIEW)

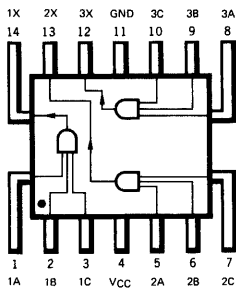

SCHEMATIC DIAGRAM (EACH EXPANDER)

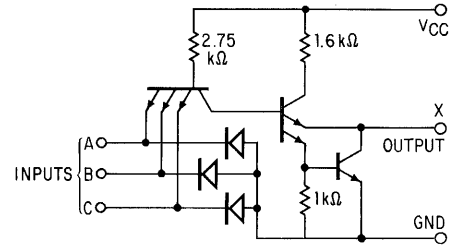

Component values shown are typical.

When connected to the X input of the 9H52/54H52, 74H52 circuit.

RECOMMENDED OPERATING CONDITIONS

PARAMETER	9H61XM/54H61XM			9H61XC/74H61XC			UNITS
	MIN.	TYP.	MAX.	MIN.	TYP.	MAX.	
Supply Voltage V_{CC}	4.5	5.0	5.5	4.75	5.0	5.25	Volts
Operating Free-Air Temperature Range	-55	25	125	0	25	70	°C

X = package type; F for Flatpak, D for Ceramic Dip, P for Plastic Dip. See Packaging Information Section for packages available on this product.

ELECTRICAL CHARACTERISTICS OVER OPERATING TEMPERATURE RANGE (Unless Otherwise Noted)

SYMBOL	PARAMETER	LIMITS			UNITS	TEST CONDITIONS (Note 1)	TEST FIGURE
		MIN.	TYP. (Note 2)	MAX.			
V_{IH}	Input HIGH Voltage	2.0			Volts	(Note 3)	114
V_{IL}	Input LOW Voltage			0.8	Volts	(Note 4)	113
V_{ON}	On-State Output Voltage			1.0	Volts	$V_{CC} = \text{MIN.}, V_{IH} = 2 \text{ V}$ $T_A = -55^\circ \text{C}, I_{ON} = 4.5 \text{ mA}$ $T_A = 0^\circ \text{C}, I_{ON} = 5.35 \text{ mA}$	114
I_{OFF}	Off-State Output Current			50	μA	$V_{CC} = \text{MIN.}, V_{IL} = 0.8 \text{ V}$ $V_{OFF} = 2.2 \text{ V}, T_A = \text{MAX.}$	113
I_{IH}	Input HIGH Current			50	μA	$V_{CC} = \text{MAX.}, V_{IN} = 2.4 \text{ V}$ $V_{CC} = \text{MAX.}, V_{IN} = 5.5 \text{ V}$	Each Input 78
I_{IL}	Input LOW Current			1.0	mA		
$I_{CC(ON)}$	On-State Supply Current		11	16	mA	$V_{CC} = \text{MAX.}, V_{IN} = 0.4 \text{ V}$	Each Input 79
$I_{CC(OFF)}$	Off-State Supply Current		5.0	7.0	mA	$V_{CC} = \text{MAX.}, V_{IN} = 0 \text{ V}$	81

OUTPUT CAPACITANCE, V_{CC} AND GND TERMINALS OPEN ($T_A = 25^\circ \text{C}$)

SYMBOL	PARAMETER	LIMITS			UNITS	TEST CONDITIONS	TEST FIGURE
		MIN.	TYP.	MAX.			
C_X	Effective Capacitance of Output Transistor Q_1		1.3		pF	$f = 1 \text{ MHz}$	CC

NOTES:

- (1) For conditions shown as MIN. or MAX., use the appropriate value specified under recommended operating conditions for the applicable device type.
- (2) Typical limits are at $V_{CC} = 5.0 \text{ V}, 25^\circ \text{C}$.
- (3) Required at all input terminals to ensure output is in the on state.
- (4) Required at any input terminal to ensure output is in the off state.

3-2-2-3-INPUT AND-OR EXPANDER

LOGIC AND CONNECTION DIAGRAM

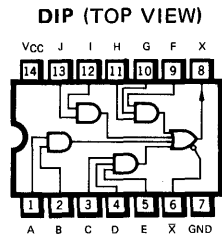

Positive logic:
 $X = (AB) + (CDE) + (FGH) + (IJ)$

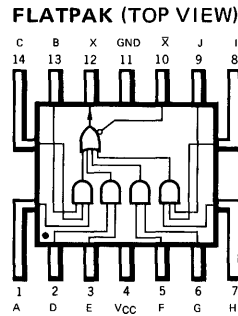

Positive logic:
 $X = (ABC) + (DE) + (FG) + (HIJ)$

SCHEMATIC DIAGRAM

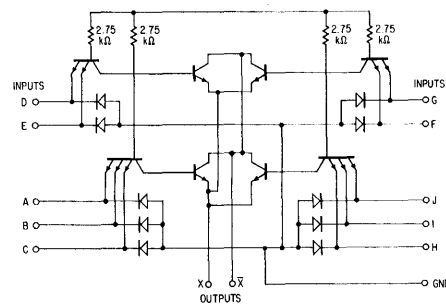

Component values shown are typical.

When connected to X and \bar{X} pins of 9H50/54H50, 74H50; 9H53/54H53, 74H53 or 9H55/54H55, 74H55 circuit.
RECOMMENDED OPERATING CONDITIONS

PARAMETER	9H62XM/54H62XM			9H62XC/74H62XC			UNITS
	MIN.	TYP.	MAX.	MIN.	TYP.	MAX.	
Supply Voltage V_{CC}	4.5	5.0	5.5	4.75	5.0	5.25	Volts
Operating Free-Air Temperature Range	-55	25	125	0	25	70	°C
Maximum number of expanders that may be fanned in to one expandable AND OR Invert Gate			1			1	

X = package type; F for Flatpak, D for Ceramic Dip, P for Plastic Dip. See Packaging Information Section for packages available on this product.

ELECTRICAL CHARACTERISTICS OVER OPERATING TEMPERATURE RANGE (Unless Otherwise Noted)

SYMBOL	PARAMETER	LIMITS			UNITS	TEST CONDITIONS (Note 1)	TEST FIGURE
		MIN.	TYP. (Note 2)	MAX.			
V_{IH}	Input HIGH Voltage	2.0			Volts	(Note 3)	115
V_{IL}	Input LOW Voltage			0.8	Volts	(Note 4)	116
V_{ON}	On-State Output Voltage			0.4	Volts	$V_{CC} = \text{MIN.}, V_{IN} = 2.0 \text{ V}, V_1 = 1.0 \text{ V}$ $T_A = -55^\circ \text{C}, I_{ON} = 5.85 \text{ mA}$ $T_A = 0^\circ \text{C}, I_{ON} = 6.3 \text{ mA}$	115
				0.4	Volts	$V_{CC} = \text{MAX.}, V_{IN} = 2.0 \text{ V}, V_1 = 0.6 \text{ V}$ $T_A = 125^\circ \text{C}, I_{ON} = 7.85 \text{ mA}$ $T_A = 70^\circ \text{C}, I_{ON} = 7.4 \text{ mA}$	
I_{OFF}	Off-State Output Current			320	μA	$T_A = -55^\circ \text{C}$	116
				570	μA	$T_A = 0^\circ \text{C}$	
I_{ON}	On-State Output Current	-470			μA	$T_A = -55^\circ \text{C}$	117
		-600			μA	$T_A = 0^\circ \text{C}$	
I_{IH}	Input HIGH Current			50	μA	$V_{CC} = \text{MAX.}, V_{IN} = 2.4 \text{ V}$	Each Input
				1.0	mA	$V_{CC} = \text{MAX.}, V_{IN} = 5.5 \text{ V}$	
I_{IL}	Input LOW Current			-2.0	mA	$V_{CC} = \text{MAX.}, V_{IN} = 0.4 \text{ V}$, Each Input	118
$I_{CC(ON)}$	On-State Supply Current		3.8	7.0	mA	$V_{CC} = \text{MAX.}, V_{IN} = 4.5 \text{ V}, V_1 = 0.85 \text{ V}$	120
$I_{CC(OFF)}$	Off-State Supply Current		6.0	9.0	mA	$V_{CC} = \text{MAX.}, V_{IN} = 0 \text{ V}, V_1 = 0.85 \text{ V}$	120

OUTPUT CAPACITANCE, V_{CC} AND GND TERMINALS OPEN ($T_A = 25^\circ \text{C}$)

SYMBOL	PARAMETER	LIMITS			UNITS	TEST CONDITIONS	TEST FIGURE
		MIN.	TYP.	MAX.			
$C_{\bar{X}}$	Effective Capacitance of Output Transistor Q_1		1.3		pF	$f = 1 \text{ MHz}$	BB

NOTES:

- (1) For conditions shown as MIN. or MAX., use the appropriate value specified under recommended operating conditions for the applicable device type.
- (2) Typical limits are at $V_{CC} = 5.0 \text{ V}, 25^\circ \text{C}$.
- (3) Required at all input terminals of one AND section to ensure output is in the on state.
- (4) Required at one input terminal of each AND section to ensure output is in the off state.



4-2-3-2-INPUT AND-OR-INVERT GATE

LOGIC AND CONNECTION DIAGRAM
DIP (TOP VIEW)

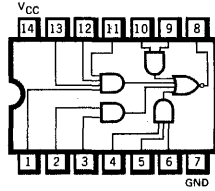

Positive logic: $ABCD + EF + GHE + JK$

SCHEMATIC DIAGRAM

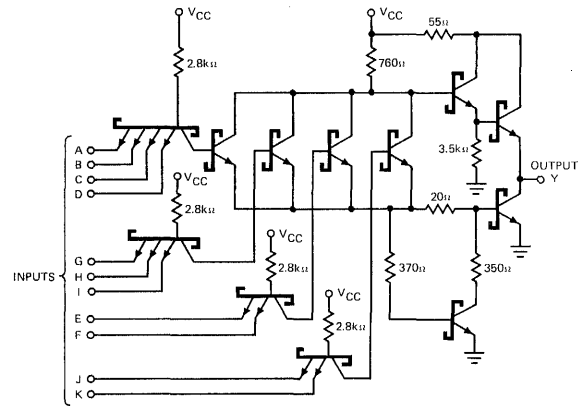

All inputs have Schottky clamp diodes.
Component values shown are typical.

RECOMMENDED OPERATING CONDITIONS

PARAMETER	9S64XM/54S64XM			9S64XC/74S64XC			UNITS
	MIN.	TYP.	MAX.	MIN.	TYP.	MAX.	
Supply Voltage V_{CC}	4.5	5.0	5.5	4.75	5.0	5.25	Volts
Operating Free-Air Temperature Range	-55	25	125	0	25	75	°C
Input Loading for Each Input			1.25			1.25	U.L.

X = package type; F for Flatpak, D for Ceramic Dip, P for Plastic Dip. See Packaging Information Section for packages available on this product.

ELECTRICAL CHARACTERISTICS OVER OPERATING TEMPERATURE RANGE (Unless Otherwise Noted)

SYMBOL	PARAMETER	LIMITS			UNITS	TEST CONDITIONS (Note 1)
		MIN.	TYP. (Note 2)	MAX.		
V_{IH}	Input HIGH Voltage	2.0			Volts	Guaranteed Input HIGH Voltage
V_{IL}	Input LOW Voltage			0.8	Volts	Guaranteed Input LOW Voltage
V_{CD}	Input Clamp Diode Voltage		-0.65	-1.2	Volts	$V_{CC} = \text{MIN.}, I_{IN} = -18 \text{ mA}$
V_{OH}	Output HIGH Voltage	XM	2.5	3.4	Volts	$V_{CC} = \text{MIN.}, I_{OH} = -1.0 \text{ mA}, V_{IN} = 0.8 \text{ V}$
		XC	2.7	3.4		
V_{OL}	Output LOW Voltage		0.35	0.5	Volts	$V_{CC} = \text{MIN.}, I_{OL} = 20 \text{ mA}, V_{IN} = 2.0 \text{ V}$
I_{IH}	Input HIGH Current		1.0	50	μA	$V_{CC} = \text{MAX.}, V_{IN} = 2.7 \text{ V}$
				1.0	mA	$V_{CC} = \text{MAX.}, V_{IN} = 5.5 \text{ V}$
I_{IL}	Input LOW Current		-1.4	-2.0	mA	$V_{CC} = \text{MAX.}, V_{IN} = 0.5 \text{ V}$
I_{OS}	Output Short Circuit Current _{avg} (Note 3)	-40	-65	-100	mA	$V_{CC} = \text{MAX.}, V_{OUT} = 0\text{V}$
I_{CCH}	Supply Current HIGH		7.0	12.5	mA	$V_{CC} = \text{MAX.}, V_{IN} = 0 \text{ V}$
I_{CCL}	Supply Current LOW		8.5	16	mA	$V_{CC} = \text{MAX.}, (\text{Note 4})$

SWITCHING CHARACTERISTICS ($T_A = 25^\circ\text{C}$)

SYMBOL	PARAMETER	LIMITS			UNITS	TEST CONDITIONS	TEST FIGURES
		MIN.	TYP.	MAX.			
t_{PLH}	Turn Off Delay Input to Output	2.0	3.5	5.5	ns	$V_{CC} = 5.0 \text{ V}$ $C_L = 15 \text{ pF}$	FF
t_{PHL}	Turn On Delay Input to Output	2.0	3.5	5.5	ns		

NOTES:

- (1) For conditions shown as MIN. or MAX., use the appropriate value specified under recommended operating conditions for the applicable device type.
- (2) Typical limits are at $V_{CC} = 5.0 \text{ V}, 25^\circ\text{C}$.
- (3) Not more than one output should be shorted at a time.
- (4) I_{CCL} is measured with all inputs of one gate open, and remaining inputs grounded.

4-2-3-2-INPUT AND-OR-INVERT GATE (WITH OPEN COLLECTOR)

LOGIC AND CONNECTION DIAGRAM
DIP (TOP VIEW)

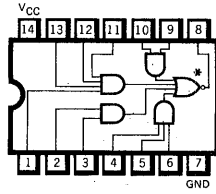

* OPEN COLLECTOR

Positive logic: $\overline{ABCD} + \overline{EF} + \overline{GHI} + \overline{JK}$

SCHEMATIC DIAGRAM

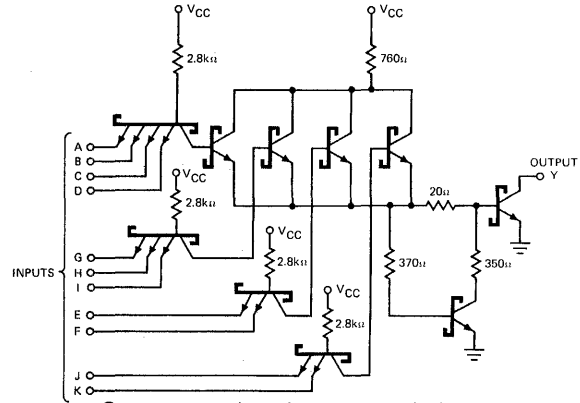

Component values shown are typical.
All inputs have clamp diodes (not shown).

RECOMMENDED OPERATING CONDITIONS

PARAMETER	† 9S65XM/54S65XM			9S65XC/74S65XC			UNITS
	MIN.	TYP.	MAX.	MIN.	TYP.	MAX.	
Supply Voltage V_{CC}	4.5	5.0	5.5	4.75	5.0	5.25	Volts
Operating Free-Air Temperature Range	-55	25	125	0	25	75	°C
Input Loading for Each Input			1.25			1.25	U.L.

X = package type; F for Flatpak, D for Ceramic Dip, P for Plastic Dip. See Packaging Information Section for packages available on this product.

ELECTRICAL CHARACTERISTICS OVER OPERATING TEMPERATURE RANGE (Unless Otherwise Noted)

SYMBOL	PARAMETER	LIMITS			UNITS	TEST CONDITIONS (Note 1)
		MIN.	TYP. (Note 2)	MAX.		
V_{IH}	Input HIGH Voltage	2.0			Volts	Guaranteed Input HIGH Voltage
V_{IL}	Input LOW Voltage			0.8	Volts	Guaranteed Input LOW Voltage
V_{CD}	Input Clamp Diode Voltage			-1.2	Volts	$V_{CC} = \text{MIN.}, I_{IN} = -18 \text{ mA}$
I_{OH}	Output HIGH Current		0.1	250	μA	$V_{CC} = \text{MIN.}, V_{OH} = 5.5 \text{ V}, V_{IN} = 0.8 \text{ V}$
V_{OL}	Output LOW Voltage		0.35	0.5	Volts	$V_{CC} = \text{MIN.}, I_{OL} = 20 \text{ mA}, V_{IN} = 2.0 \text{ V}$
I_{IH}	Input HIGH Current		1.0	50	μA	$V_{CC} = \text{MAX.}, V_{IN} = 2.7 \text{ V}$
				1.0	mA	$V_{CC} = \text{MAX.}, V_{IN} = 5.5 \text{ V}$
I_{IL}	Input LOW Current		-1.4	-2.0	mA	$V_{CC} = \text{MAX.}, V_{IN} = 0.5 \text{ V}$
I_{CCH}	Supply Current HIGH		6.0	11.0	mA	$V_{CC} = \text{MAX.}, V_{IN} = 0 \text{ V}$
I_{CCL}	Supply Current LOW		8.5	16	mA	$V_{CC} = \text{MAX.}, (\text{Note 3})$

SWITCHING CHARACTERISTICS ($T_A = 25^\circ\text{C}$)

SYMBOL	PARAMETER	LIMITS			UNITS	TEST CONDITIONS	TEST FIGURES
		MIN.	TYP.	MAX.			
tPLH	Turn Off Delay Input to Output	2.0	5.0	7.5	ns	$V_{CC} = 5.0 \text{ V}$ $C_L = 15 \text{ pF}$	FF
tPHL	Turn On Delay Input to Output	2.0	5.5	8.5	ns		

NOTES:

- (1) For conditions shown as MIN. or MAX., use the appropriate value specified under recommended operating conditions for the applicable device type.
- (2) Typical limits are at $V_{CC} = 5.0 \text{ V}, 25^\circ\text{C}$.
- (3) I_{CCL} is measured with all inputs of one gate open, and remaining inputs grounded.

EDGE TRIGGERED JK FLIP-FLOP

DESCRIPTION — The 9N70/5470, 7470 is a gated input edge triggered JK flip-flop offering direct clear and preset inputs, and complementary Q and \bar{Q} outputs. Information at the J and K inputs is transferred to the outputs on the positive edge of the clock pulse.

Direct-coupled clock triggering occurs at a specific voltage level of the clock pulse, when the clock input threshold voltage has been passed, the gated inputs are locked out.

These flip-flops are designed for medium to high speed applications and offer a significant saving in system power dissipation and package count where input gating is required.

LOGIC AND CONNECTION DIAGRAM

DIP (TOP VIEW)

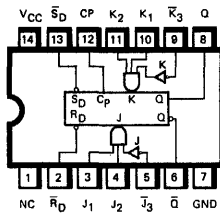

NC — No internal connection.

FLATPAK (TOP VIEW)

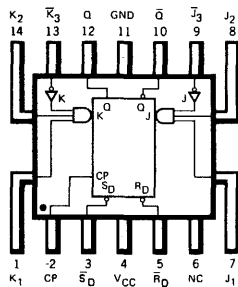

SCHEMATIC DIAGRAM

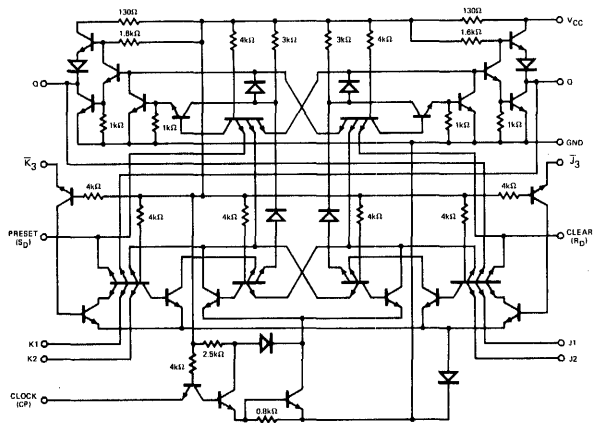

Component values shown are typical.

Positive logic:

LOW input to preset sets Q to HIGH level
 LOW input to clear sets Q to LOW level
 Preset or clear function can occur only when clock input is LOW

TRUTH TABLE

t_n		t_{n+1}
J	K	Q
L	L	Q_n
L	H	L
H	L	H
H	H	\bar{Q}_n

NOTES:
 $J = J_1 \cdot J_2 \cdot J_3$
 $K = K_1 \cdot K_2 \cdot K_3$
 t_n = Bit time before clock pulse.
 t_{n+1} = Bit time after clock pulse.
 If inputs J3 or K3 are not used they must be grounded.

LOGIC DIAGRAM

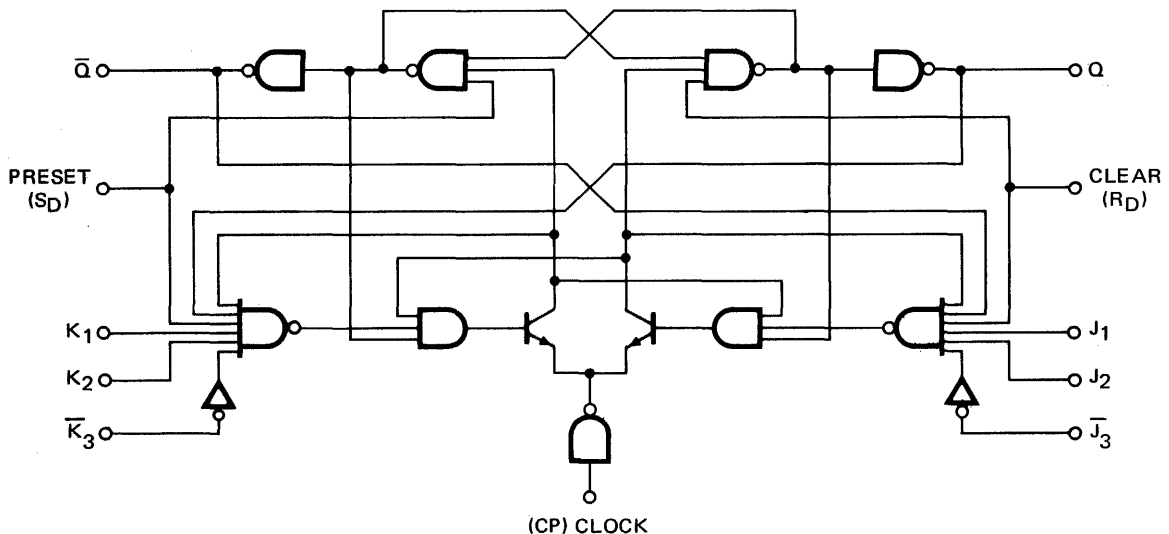

FAIRCHILD TTL/SSI • 9N70/5470, 7470

RECOMMENDED OPERATING CONDITIONS

PARAMETER	9N70XM/5470XM			9N70XC/7470XC			UNITS
	MIN.	TYP.	MAX.	MIN.	TYP.	MAX.	
Supply Voltage V_{CC}	4.5	5.0	5.5	4.75	5.0	5.25	Volts
Operating Free-Air Temperature Range	-55	25	125	0	25	70	°C
Normalized Fan Out from Each Output, N			10			10	U.L.
Clock Pulse Transition Time to HIGH Level, $t_1(\text{clock})$ (See Fig. D)	5.0		150	5.0		150	ns
Width of Clock Pulse, $t_p(\text{clock})$ (See Fig. D)	20			20			ns
Width of Preset Pulse, $t_p(\text{preset})$ (See Fig. C)	25			25			ns
Width of Clear Pulse, $t_p(\text{clear})$ (See Fig. C)	25			25			ns

X = package type; F for Flatpak, D for Ceramic Dip, P for Plastic Dip. See Packaging Information Section for packages available on this product.

ELECTRICAL CHARACTERISTICS OVER OPERATING TEMPERATURE RANGE (Unless Otherwise Noted)

SYMBOL	PARAMETER	LIMITS			UNITS	TEST CONDITIONS (Note 1)	TEST FIGURE
		MIN.	TYP. (Note 2)	MAX.			
V_{IH}	Input HIGH Voltage	2.0			Volts	Guaranteed Input HIGH	36 & 37
V_{IL}	Input LOW Voltage			0.8	Volts	Guaranteed Input LOW	36 & 37
V_{OH}	Output HIGH Voltage	2.4	3.5		Volts	$V_{CC} = \text{MIN.}, I_{OH} = -0.4 \text{ mA}$	36
V_{OL}	Output LOW Voltage		0.22	0.4	Volts	$V_{CC} = \text{MIN.}, I_{OL} = 16 \text{ mA}$	37
I_{IH}	Input HIGH Current at $J_1, J_2, J_3, K_1, K_2, \bar{K}_3$ or Clock			40	μA	$V_{CC} = \text{MAX.}, V_{IN} = 2.4 \text{ V}$	39
				1.0	mA	$V_{CC} = \text{MAX.}, V_{IN} = 5.5 \text{ V}$	
	Input HIGH Current at Clear or Preset			80	μA	$V_{CC} = \text{MAX.}, V_{IN} = 2.4 \text{ V}$	39
				1.0	mA	$V_{CC} = \text{MAX.}, V_{IN} = 5.5 \text{ V}$	
I_{IL}	Input LOW Current at $J_1, J_2, J_3, K_1, K_2, \bar{K}_3$ or Clock			-1.6	mA	$V_{CC} = \text{MAX.}, V_{IN} = 0.4 \text{ V}$	38
	Input LOW Current at Clear or Preset			-3.2	mA	$V_{CC} = \text{MAX.}, V_{IN} = 0.4 \text{ V}$	38
I_{OS}	Output Short Circuit Current (Note 3)	-20		-57	mA	9N70/5470 $V_{CC} = \text{MAX.}$	40
		-18		-57	mA	9N70/7470 $V_{IN} = 0 \text{ V}$	
I_{CC}	Supply Current		13	26	mA	$V_{CC} = \text{MAX.}, V_{IN} = 5.0 \text{ V}$	39

SWITCHING CHARACTERISTICS ($T_A = 25^\circ\text{C}$)

SYMBOL	PARAMETER	LIMITS			UNITS	TEST CONDITIONS	TEST FIGURE
		MIN.	TYP.	MAX.			
f_{max}	Maximum Clock Frequency	20	35		MHz	$V_{CC} = 5.0 \text{ V}$ $C_L = 15 \text{ pF}$ $R_L = 400\Omega$	D
t_{setup}	Maximum Input Setup Time		10	20	ns		D
t_{hold}	Maximum Input Hold Time		0	5.0	ns		D
t_{PLH}	Turn Off Delay Clear or Preset to Output			50	ns		C
t_{PHL}	Turn On Delay Clear or Preset to Output			50	ns		C
t_{PLH}	Turn Off Delay Clock to Output	10	27	50	ns		D
t_{PHL}	Turn On Delay Clock to Output	10	18	50	ns		D

NOTES:

- (1) For conditions shown as MIN. or MAX., use the appropriate value specified under recommended operating conditions for the applicable device type.
- (2) Typical limits are at $V_{CC} = 5.0 \text{ V}, 25^\circ\text{C}$.
- (3) Not more than one output should be shorted at a time.

5

JK MASTER/SLAVE FLIP-FLOP WITH AND-OR INPUTS

DESCRIPTION — The HSTTL/SSI 9H71/54H71, 74H71 is a High Speed JK Master/Slave flip-flop with AND-OR gate inputs. The AND-OR gate inputs for entry into the master section are controlled by the clock pulse. The clock pulse also regulates the circuitry which connects the master and slave sections. The sequence of operation is as follows: 1) Isolate slave from master. 2) Enter information from AND-OR gate inputs to master. 3) Disable AND-OR gate inputs. 4) Transfer information from master to slave. Logic state of J and K inputs must not be allowed to change when the clock pulse is in a HIGH state.

LOGIC AND CONNECTION DIAGRAM

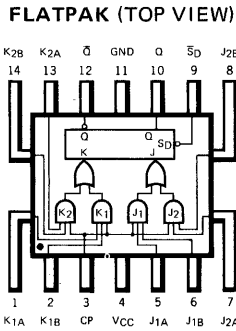
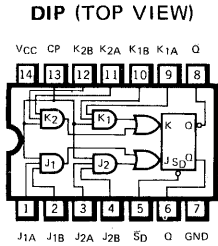

SCHEMATIC DIAGRAM

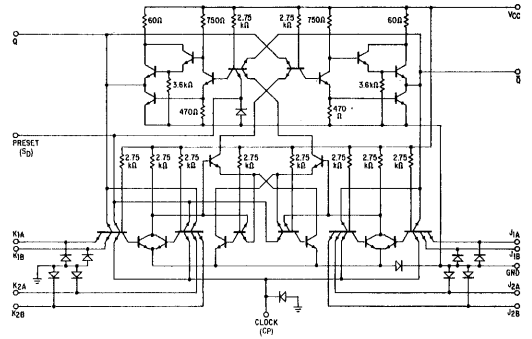

Positive logic:
 LOW input to preset sets Q to HIGH level
 Preset is independent of clock

Component values shown are typical.

TRUTH TABLE

t_n		t_{n+1}
J	K	Q
L	L	Q_n
L	H	L
H	L	H
H	H	\bar{Q}_n

CLOCK WAVEFORM

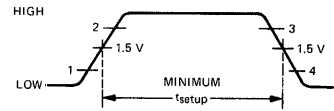

NOTES:
 $J = (J1A \cdot J1B) + (J2A \cdot J2B)$
 $K = (K1A \cdot K1B) + (K2A \cdot K2B)$
 t_n = Bit time before clock pulse
 t_{n+1} = Bit time after clock pulse

LOGIC DIAGRAM

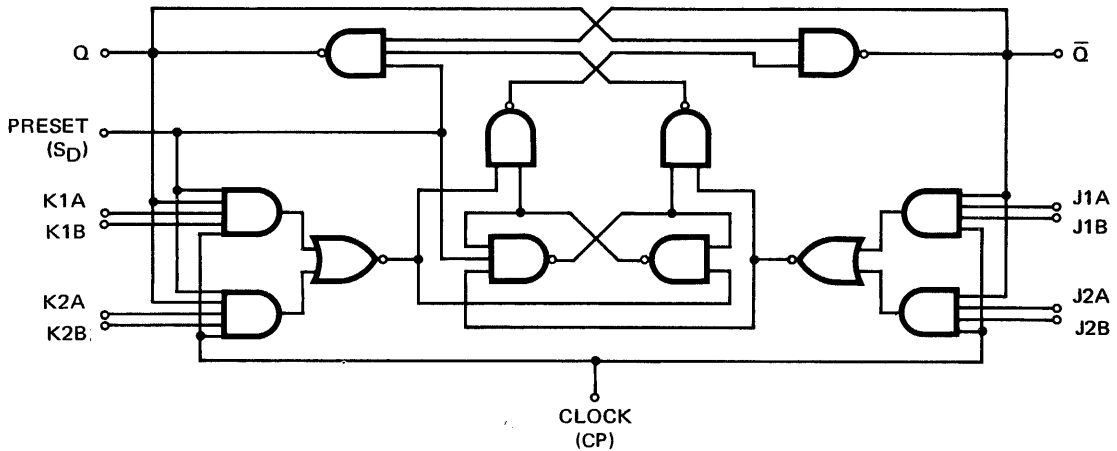

FAIRCHILD HIGH SPEED TTL/SSI • 9H71/54H71, 74H71

RECOMMENDED OPERATING CONDITIONS

PARAMETER	9H71XM/54H71XM			9H71XC/74H71XC			UNITS
	MIN.	TYP.	MAX.	MIN.	TYP.	MAX.	
Supply Voltage V_{CC}	4.5	5.0	5.5	4.75	5.0	5.25	Volts
Operating Free-Air Temperature Range	-55	25	125	0	25	70	°C
Fan Out from Each Output			12.5			12.5	U.L.
Width of Clock Pulse, $t_{p(\text{clock})}$ (See Fig. W)	12			12			ns
Width of Preset Pulse, $t_{p(\text{preset})}$ (See Fig. X)	16			16			ns
Input Setup Time, t_{setup} (See Clock Waveform)	$\geq t_{p(\text{clock})}$			$\geq t_{p(\text{clock})}$			
Input Hold Time, t_{hold}	0			0			

X = package type; F for Flatpak, D for Ceramic Dip, P for Plastic Dip. See Packaging Information Section for packages available on this product.

ELECTRICAL CHARACTERISTICS OVER OPERATING TEMPERATURE RANGE (Unless Otherwise Noted)

SYMBOL	PARAMETER	LIMITS			UNITS	TEST CONDITIONS (Note 1)	TEST FIGURE
		MIN.	TYP. (Note 2)	MAX.			
V_{IH}	Input HIGH Voltage	2.0			Volts	Guaranteed Input HIGH	121 & 122
V_{IL}	Input LOW Voltage			0.8	Volts	Guaranteed Input LOW	121 & 122
V_{OH}	Output HIGH Voltage	2.4			Volts	$V_{CC} = \text{MIN.}, I_{OH} = -0.5 \text{ mA}$	121
V_{OL}	Output LOW Voltage			0.4	Volts	$V_{CC} = \text{MIN.}, I_{OL} = 20 \text{ mA}$	122
I_{IH}	Input HIGH Current at J1A, J1B, J2A, J2B, K1A, K1B, K2A, or K2B			50	μA	$V_{CC} = \text{MAX.}, V_{IN} = 2.4 \text{ V}$	124
				1.0	mA	$V_{CC} = \text{MAX.}, V_{IN} = 5.5 \text{ V}$	
	Input HIGH Current at Preset			150	μA	$V_{CC} = \text{MAX.}, V_{IN} = 2.4 \text{ V}$	124
				1.0	mA	$V_{CC} = \text{MAX.}, V_{IN} = 5.5 \text{ V}$	
I_{IL}	Input LOW Current at J1A, J1B, J2A, J2B, K1A, K1B, K2A, or K2B			-2.0	mA	$V_{CC} = \text{MAX.}, V_{IN} = 0.4 \text{ V}$	123
				-6.0	mA	$V_{CC} = \text{MAX.}, V_{IN} = 0.4 \text{ V}$	
	Input LOW Current at Clock			-4.0	mA	$V_{CC} = \text{MAX.}, V_{IN} = 0.4 \text{ V}$	123
I_{OS}	Output Short Circuit Current (Note 3)	-40		-100	mA	$V_{CC} = \text{MAX.}, V_{IN} = 0 \text{ V}$	127
I_{CC}	Supply Current		19	30	mA	$V_{CC} = \text{MAX.}$	124

SWITCHING CHARACTERISTICS ($T_A = 25^\circ\text{C}$)

SYMBOL	PARAMETER	LIMITS			UNITS	TEST CONDITIONS	TEST FIGURE
		MIN.	TYP.	MAX.			
f_{CLOCK}	Maximum Clock Frequency	25	30		MHz	$V_{CC} = 5.0 \text{ V}$ $C_L = 25 \text{ pF}$ $R_L = 280\Omega$	W
t_{PLH}	Turn Off Delay Preset to Output		6.0	13	ns		X
t_{PHL}	Turn On Delay Preset to Output		12	24	ns		X
t_{PLH}	Turn Off Delay Clock to Output	6.0	14	21	ns		W
t_{PHL}	Turn On Delay Clock to Output	10	22	27	ns		W

NOTES:

- (1) For conditions shown as MIN. or MAX., use the appropriate value specified under recommended operating conditions for the applicable device type.
- (2) Typical limits are at $V_{CC} = 5.0 \text{ V}, 25^\circ\text{C}$.
- (3) Not more than one output should be shorted at a time, and duration of short-circuit test should not exceed 1 second.

JK MASTER/SLAVE FLIP-FLOP WITH AND INPUTS

DESCRIPTION — The HSTTL/SSI 9H72/54H72, 74H72 is a High Speed JK Master/Slave flip-flop with AND gate inputs. The AND gate inputs for entry into the master section are controlled by the clock pulse. The clock pulse also regulates the circuitry which connects the master and slave sections. The sequence of operation is as follows: 1) Isolate slave from master. 2) Enter information from AND gate inputs to master. 3) Disable AND gate inputs. 4) Transfer information from master to slave. Logic state of J and K inputs must not be allowed to change when the clock pulse is in a HIGH state.

LOGIC AND CONNECTION DIAGRAM

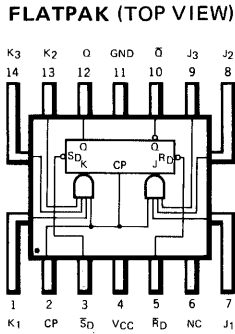
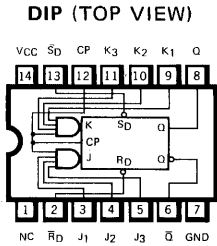

NC — No internal connection.

Positive logic:

- LOW input to preset sets Q to HIGH level
- LOW input to clear sets Q to LOW level
- Preset and clear are independent of clock

TRUTH TABLE

t_n		t_{n+1}
J	K	Q
L	L	Q_n
L	H	L
H	L	H
H	H	\bar{Q}_n

NOTES:

- J = J1·J2·J3
- K = K1·K2·K3
- t_n = Bit time before clock pulse
- t_{n+1} = Bit time after clock pulse

SCHEMATIC DIAGRAM

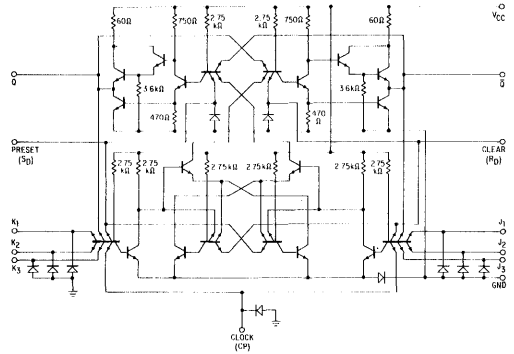

Component values shown are typical.

CLOCK WAVEFORM

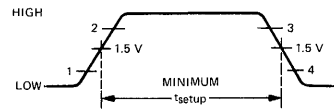

LOGIC DIAGRAM

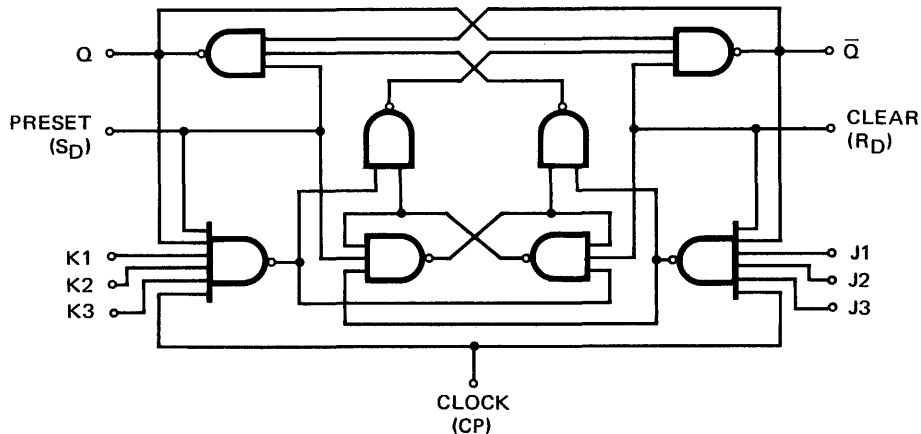

FAIRCHILD HIGH SPEED TTL/SSI • 9H72/54H72, 74LS72

RECOMMENDED OPERATING CONDITIONS

PARAMETER	9H72XM/54H72XM			9H72XC/74H72XC			UNITS
	MIN.	TYP.	MAX.	MIN.	TYP.	MAX.	
Supply Voltage V_{CC}	4.5	5.0	5.5	4.75	5.0	5.25	Volts
Operating Free-Air Temperature Range	-55	25	125	0	25	70	°C
Fan Out from Each Output			12.5			12.5	U.L.
Width of Clock Pulse, $t_{p(\text{clock})}$ (See Fig. W)	12			12			ns
Width of Preset Pulse, $t_{p(\text{preset})}$ (See Fig. X)	16			16			ns
Width of Clear Pulse, $t_{p(\text{clear})}$ (See Fig. X)	16			16			ns
Input Setup Time, t_{setup} (See Clock Waveform)	$\geq t_{p(\text{clock})}$			$\geq t_{p(\text{clock})}$			
Input Hold Time, t_{hold}	0			0			

X = package type; F for Flatpak, D for Ceramic Dip, P for Plastic Dip. See Packaging Information Section for packages available on this product.

ELECTRICAL CHARACTERISTICS OVER OPERATING TEMPERATURE RANGE (Unless Otherwise Noted)

SYMBOL	PARAMETER	LIMITS			UNITS	TEST CONDITIONS (Note 1)	TEST FIGURE
		MIN.	TYP. (Note 2)	MAX.			
V_{IH}	Input HIGH Voltage	2.0			Volts	Guaranteed Input HIGH	41 & 42
V_{IL}	Input LOW Voltage			0.8	Volts	Guaranteed Input LOW	41 & 42
V_{OH}	Output HIGH Voltage	2.4			Volts	$V_{CC} = \text{MIN.}, I_{OH} = -0.5 \text{ mA}$	41
V_{OL}	Output LOW Voltage			0.4	Volts	$V_{CC} = \text{MIN.}, I_{OL} = 20 \text{ mA}$	42
I_{IH}	Input HIGH Current at J2, J3, K1, K2, or K3			50	μA	$V_{CC} = \text{MAX.}, V_{IN} = 2.4 \text{ V}$	44
				1.0	mA	$V_{CC} = \text{MAX.}, V_{IN} = 5.5 \text{ V}$	
	Input HIGH Current at J1,			50	μA	$V_{CC} = \text{MAX.}, V_{IN} = 2.4 \text{ V}$	44
				1.0	mA	$V_{CC} = \text{MAX.}, V_{IN} = 5.5 \text{ V}$	
I_{IL}	Input LOW Current at J1, J2, J3, K1, K2, K3, or Clock			-2.0	mA	$V_{CC} = \text{MAX.}, V_{IN} = 0.4 \text{ V}$	43
				-4.0	mA	$V_{CC} = \text{MAX.}, V_{IN} = 0.4 \text{ V}$	43
I_{OS}	Output Short Circuit Current (Note 3)	-40		-100	mA	$V_{CC} = \text{MAX.}, V_{IN} = 0 \text{ V}$	45
I_{CC}	Supply Current		16	25	mA	$V_{CC} = \text{MAX.}$	44

SWITCHING CHARACTERISTICS ($T_A = 25^\circ\text{C}$)

SYMBOL	PARAMETER	LIMITS			UNITS	TEST CONDITIONS	TEST FIGURE
		MIN.	TYP.	MAX.			
f_{CLOCK}	Maximum Clock Frequency	25	30		MHz	$V_{CC} = 5.0 \text{ V}$ $C_L = 25 \text{ pF}$ $R_L = 280 \Omega$	W
t_{PLH}	Turn Off Delay Clear or Preset to Output		6.0	13	ns		X
t_{PHL}	Turn On Delay Clear or Preset to Output		12	24	ns		X
t_{PLH}	Turn Off Delay Clock to Output	6.0	14	21	ns		W
t_{PHL}	Turn On Delay Clock to Output	10	22	27	ns		W

NOTES:

- (1) For conditions shown as MIN. or MAX., use the appropriate value specified under recommended operating conditions for the applicable device type.
- (2) Typical limits are at $V_{CC} = 5.0 \text{ V}, 25^\circ\text{C}$.
- (3) Note more than one output should be shorted at a time, and duration of short-circuit test should not exceed 1 second.

JK MASTER/SLAVE FLIP-FLOP WITH AND INPUTS

DESCRIPTION — The TTL/SSI 9N72/5472, 7472 is a JK Master/Slave flip-flop with AND gate inputs. The AND gate inputs for entry into the master section are controlled by the clock pulse. The clock pulse also regulates the state of the coupling transistors which connect the master and slave sections. The sequence of operation is as follows: 1) Isolate slave from master. 2) Enter information from AND gate inputs to master. 3) Disable AND gate inputs. 4) Transfer information from master to slave.

LOGIC AND CONNECTION DIAGRAM

DIP (TOP VIEW)

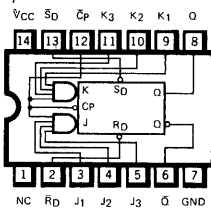

FLATPAK (TOP VIEW)

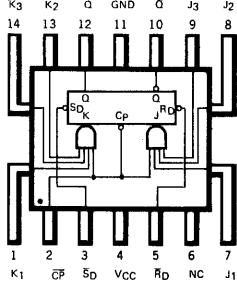

NC — No internal connection.

Positive logic:

- LOW input to preset sets Q to HIGH level
- LOW input to clear sets Q to LOW level
- Preset and clear are independent of clock

SCHEMATIC DIAGRAM

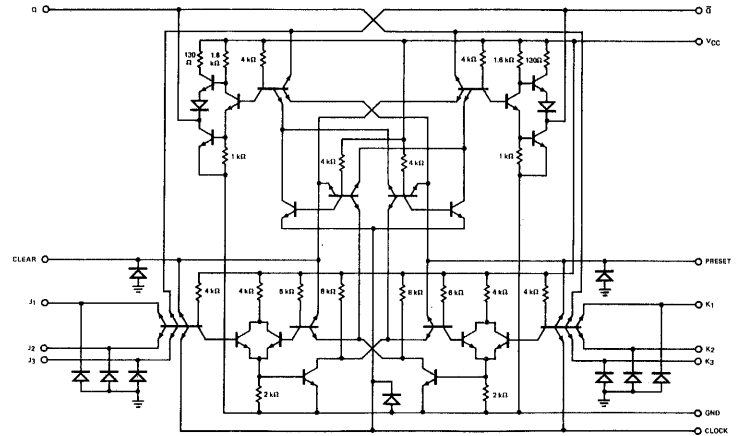

Component values shown are typical.

TRUTH TABLE

t_n		t_{n+1}
J	K	Q
L	L	Q_n
L	H	L
H	L	H
H	H	\bar{Q}_n

NOTES:

- $J = J1 \cdot J2 \cdot J3$
- $K = K1 \cdot K2 \cdot K3$
- t_n = Bit time before clock pulse.
- t_{n+1} = Bit time after clock pulse.

CLOCK WAVEFORM



LOGIC DIAGRAM

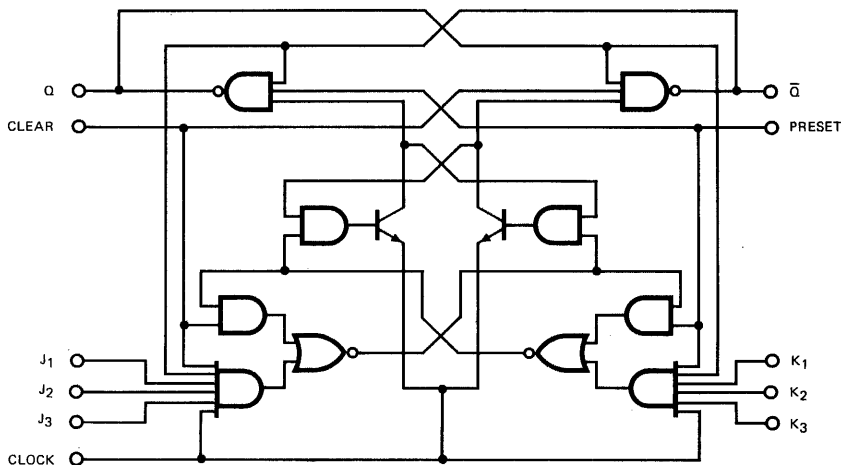

FAIRCHILD TTL/SSI • 9N72/5472, 7472

RECOMMENDED OPERATING CONDITIONS

PARAMETER	9N72XM/5472XM			9N72XC/7472XC			UNITS
	MIN.	TYP.	MAX.	MIN.	TYP.	MAX.	
Supply Voltage V_{CC}	4.5	5.0	5.5	4.75	5.0	5.25	Volts
Operating Free-Air Temperature Range	-55	25	125	0	25	70	°C
Normalized Fan Out from Each Output, N			10			10	U.L.
Width of Clock Pulse, $t_{p(\text{clock})}$ (See Fig. E)	20			20			ns
Width of Preset Pulse, $t_{p(\text{preset})}$ (See Fig. F)	25			25			ns
Width of Clear Pulse, $t_{p(\text{clear})}$ (See Fig. F)	25			25			ns
Input Setup Time, t_{setup} (See Fig. E)	$\geq t_{p(\text{clock})}$			$\geq t_{p(\text{clock})}$			
Input Hold Time, t_{hold}	0			0			

X = package type; F for Flatpak, D for Ceramic Dip, P for Plastic Dip. See Packaging Information Section for packages available on this product.

ELECTRICAL CHARACTERISTICS OVER OPERATING TEMPERATURE RANGE (Unless Otherwise Noted)

SYMBOL	PARAMETER	LIMITS			UNITS	TEST CONDITIONS (Note 1)	TEST FIGURE
		MIN.	TYP. (Note 2)	MAX.			
V_{IH}	Input HIGH Voltage	2.0			Volts	Guaranteed Input HIGH	41 & 42
V_{IL}	Input LOW Voltage			0.8	Volts	Guaranteed Input LOW	41 & 42
V_{OH}	Output HIGH Voltage	2.4	3.5		Volts	$V_{CC} = \text{MIN.}, I_{OH} = -0.4 \text{ mA}$	41
V_{OL}	Output LOW Voltage		0.22	0.4	Volts	$V_{CC} = \text{MIN.}, I_{OL} = 16 \text{ mA}$	42
I_{IH}	Input HIGH Current at J_1, J_2, J_3, K_1, K_2 or K_3			40	μA	$V_{CC} = \text{MAX.}, V_{IN} = 2.4 \text{ V}$	44
				1.0	mA	$V_{CC} = \text{MAX.}, V_{IN} = 5.5 \text{ V}$	
	Input HIGH Current at Clear Preset or Clock			80	μA	$V_{CC} = \text{MAX.}, V_{IN} = 2.4 \text{ V}$	44
				1.0	mA	$V_{CC} = \text{MAX.}, V_{IN} = 5.5 \text{ V}$	
I_{IL}	Input LOW Current at J_1, J_2, J_3, K_1, K_2 or K_3			-1.6	mA	$V_{CC} = \text{MAX.}, V_{IN} = 0.4 \text{ V}$	43
				-3.2	mA	$V_{CC} = \text{MAX.}, V_{IN} = 0.4 \text{ V}$	43
I_{OS}	Output Short Circuit Current (Note 3)	-20		-57	mA	9N72/5472 $V_{CC} = \text{MAX.}$	45
		-18		-57	mA	9N72/7472 $V_{IN} = 0 \text{ V}$	
I_{CC}	Supply Current		10	20	mA	$V_{CC} = \text{MAX.}, V_{IN} = 5.0 \text{ V}$	44

SWITCHING CHARACTERISTICS ($T_A = 25^\circ\text{C}$)

SYMBOL	PARAMETER	LIMITS			UNITS	TEST CONDITIONS	TEST FIGURE
		MIN.	TYP.	MAX.			
f_{max}	Maximum Clock Frequency	15	20		MHz	$V_{CC} = 5.0 \text{ V}$ $C_L = 15 \text{ pF}$ $R_L = 400\Omega$	E
t_{PLH}	Turn Off Delay Clear or Preset to Output		16	25	ns		F
t_{PHL}	Turn On Delay Clear or Preset to Output		25	40	ns		F
t_{PLH}	Turn Off Delay Clock to Output	10	16	25	ns		E
t_{PHL}	Turn On Delay Clock to Output	10	25	40	ns		E

NOTES:

- (1) For conditions shown as MIN. or MAX., use the appropriate value specified under recommended operating conditions for the applicable device type.
- (2) Typical limits are at $V_{CC} = 5.0 \text{ V}, 25^\circ\text{C}$.
- (3) Not more than one output should be shorted at a time.

5

DUAL JK MASTER/SLAVE FLIP-FLOP WITH SEPARATE CLEARS AND CLOCKS

DESCRIPTION — The HSTTL/SSI 9H73/54H73, 74H73 is a High Speed Dual JK Master/Slave flip-flop with separate clears and separate clocks. Inputs to the master section are controlled by the clock pulse. The clock pulse also regulates the circuitry which connects the master and slave sections. The sequence of operation is as follows: 1) Isolate slave from master. 2) Enter information from J and K inputs to master. 3) Disable J and K inputs. 4) Transfer information from master to slave. Logic state of J and K inputs must not be allowed to change when the clock pulse is in a HIGH state.

LOGIC AND CONNECTION DIAGRAM

DIP (TOP VIEW)

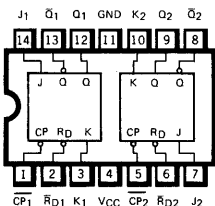

FLATPAK (TOP VIEW)

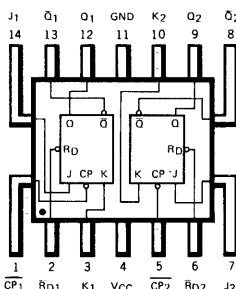

Positive logic:

LOW input to clear sets Q to LOW level
Clear is independent of clock

TRUTH TABLE

t_n		t_{n+1}
J	K	Q
L	L	Q_n
L	H	L
H	L	H
H	H	\bar{Q}_n

NOTES:

t_n = Bit time before clock pulse.
 t_{n+1} = Bit time after clock pulse.

SCHEMATIC DIAGRAM (EACH FLIP-FLOP)

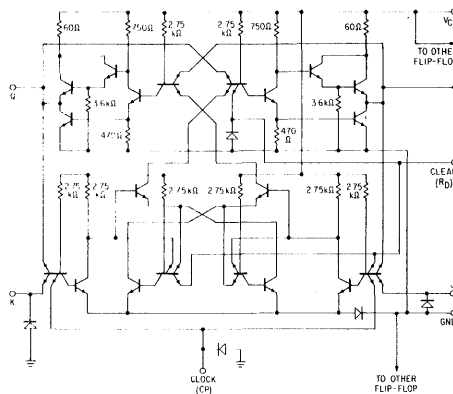

Component values shown are typical.
Resistor values are in ohms.

CLOCK WAVEFORMS

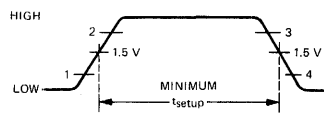

LOGIC DIAGRAM (EACH FLIP-FLOP)

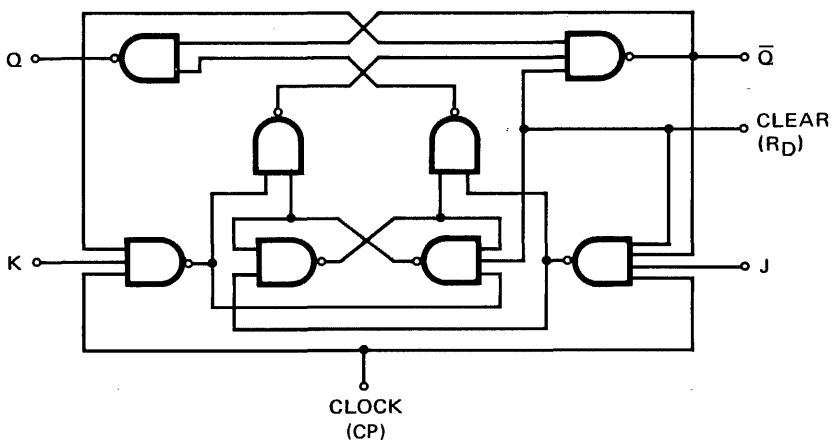

FAIRCHILD HIGH SPEED TTL/SSI • 9H73/54H73, 74H73

RECOMMENDED OPERATING CONDITIONS

PARAMETER	9H73XM/54H73XM			9H73XC/74H73XC			UNITS
	MIN.	TYP.	MAX.	MIN.	TYP.	MAX.	
Supply Voltage V_{CC}	4.5	5.0	5.5	4.75	5.0	5.25	Volts
Operating Free-Air Temperature Range	-55	25	125	0	25	70	°C
Fan Out from Each Output			12.5			12.5	U.L.
Width of Clock Pulse, $t_{p(\text{clock})}$ (See Fig. W)	12			12			ns
Width of Clear Pulse, $t_{p(\text{clear})}$ (See Fig. X)	16			16			ns
Input Setup Time, t_{setup} (See Clock Waveform)	$\geq t_{p(\text{clock})}$			$\geq t_{p(\text{clock})}$			
Input Hold Time, t_{hold}	0			0			

X = package type; F for Flaptak, D for Ceramic Dip, P for Plastic Dip. See Packaging Information Section for packages available on this product.

ELECTRICAL CHARACTERISTICS OVER OPERATING TEMPERATURE RANGE (Unless Otherwise Noted)

SYMBOL	PARAMETER	LIMITS			UNITS	TEST CONDITIONS (Note 1)	TEST FIGURE
		MIN.	TYP. (Note 2)	MAX.			
V_{IH}	Input HIGH Voltage	2.0			Volts	Guaranteed Input HIGH	46 & 47
V_{IL}	Input LOW Voltage			0.8	Volts	Guaranteed Input LOW	46 & 47
V_{OH}	Output HIGH Voltage	2.4			Volts	$V_{CC} = \text{MIN.}, I_{OH} = -0.5 \text{ mA}$	46
V_{OL}	Output LOW Voltage			0.4	Volts	$V_{CC} = \text{MIN.}, I_{OL} = 20 \text{ mA}$	47
I_{IH}	Input HIGH Current at J or K			50	μA	$V_{CC} = \text{MAX.}, V_{IN} = 2.4 \text{ V}$	126
				1.0	mA	$V_{CC} = \text{MAX.}, V_{IN} = 5.5 \text{ V}$	
	Input HIGH Current at Clock			5.0	μA	$V_{CC} = \text{MAX.}, V_{IN} = 2.4 \text{ V}$	126
				1.0	mA	$V_{CC} = \text{MAX.}, V_{IN} = 5.5 \text{ V}$	
		Input HIGH Current at Clear			100	μA	
			1.0	mA	$V_{CC} = \text{MAX.}, V_{IN} = 5.5 \text{ V}$		
I_{IL}	Input LOW Current at J, K or Clock			-2.0	mA	$V_{CC} = \text{MAX.}, V_{IN} = 0.4 \text{ V}$	125
	Input LOW Current at Clear			-4.0	mA	$V_{CC} = \text{MAX.}, V_{IN} = 0.4 \text{ V}$	125
I_{OS}	Output Short Circuit Current (Note 3)	-40		-100	mA	$V_{CC} = \text{MAX.}, V_{IN} = 0\text{V}$	50
I_{CC}	Supply Current		32	50	mA	$V_{CC} = \text{MAX.}$	126

SWITCHING CHARACTERISTICS ($T_A = 25^\circ\text{C}$)

SYMBOL	PARAMETER	LIMITS			UNITS	TEST CONDITIONS	TEST FIGURE
		MIN.	TYP.	MAX.			
f_{CLOCK}	Maximum Clock Frequency	25	30		MHz	$V_{CC} = 5.0 \text{ V}$ $C_L = 25 \text{ pF}$ $R_L = 280\Omega$	W
t_{PLH}	Turn Off Delay Clear to Output		6.0	13	ns		X
t_{PHL}	Turn On Delay Clear to Output		12	24	ns		X
t_{PLH}	Turn Off Delay Clock to Output	6.0	14	21	ns		W
t_{PHL}	Turn On Delay Clock to Output	10	22	27	ns		W

NOTES:

- (1) For conditions shown as MIN. or MAX., use the appropriate value specified under recommended operating conditions for the applicable device type.
- (2) Typical limits are at $V_{CC} = 5.0 \text{ V}, 25^\circ\text{C}$.
- (3) Not more than one output should be shorted at a time, and duration of short-circuit test should not exceed 1 second.

DUAL JK MASTER/SLAVE FLIP-FLOP WITH SEPARATE CLEARS AND CLOCKS

DESCRIPTION – The TTL/SSI 9N73/5473, 7473 and 9N107/54107, 74107 are Dual JK Master/Slave flip-flops with a separate clear and a separate clock for each flip-flop. Inputs to the master section are controlled by the clock pulse. The clock pulse also regulates the state of the coupling transistors which connect the master and slave sections. The sequence of operation is as follows: 1) Isolate slave from master. 2) Enter information from J and K inputs to master. 3) Disable J and K inputs. 4) Transfer information from master to slave.

LOGIC AND CONNECTION DIAGRAM

9N73/5473, 7473

DIP (TOP VIEW)

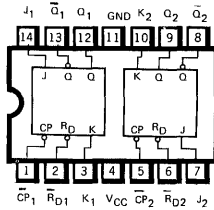

FLATPAK (TOP VIEW)

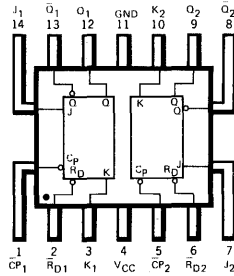

9N107/54107, 74107

DIP (TOP VIEW)

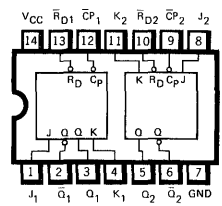

Positive logic:

LOW input to clear sets Q to LOW level
Clear is independent of clock

TRUTH TABLE

t_n		t_{n+1}
J	K	Q
L	L	Q_n
L	H	L
H	L	H
H	H	\bar{Q}_n

CLOCK WAVEFORM

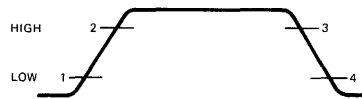

NOTES:

t_n = Bit time before clock pulse.
 t_{n+1} = Bit time after clock pulse.

LOGIC DIAGRAM
(EACH FLIP-FLOP)

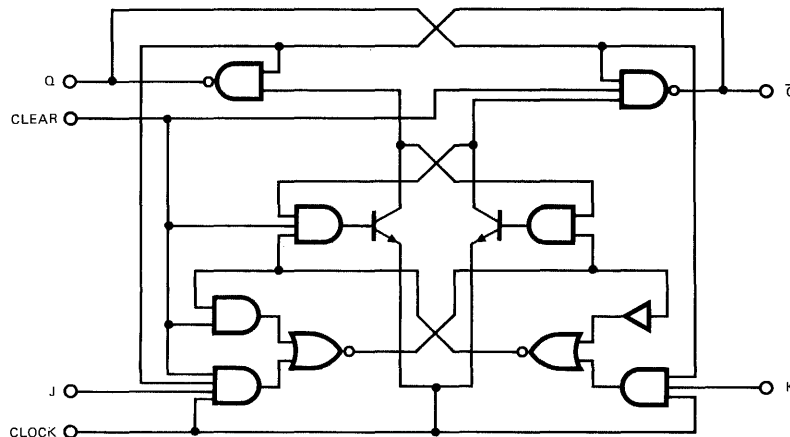

FAIRCHILD TTL/SSI • 9N73/5473, 7473 • 9N107/54107, 74107

RECOMMENDED OPERATING CONDITIONS

PARAMETER	9N73XM/5473XM 9N107XM/54107XM			9N73XC/7473XC 9N107XC/74107XC			UNITS
	MIN.	TYP.	MAX.	MIN.	TYP.	MAX.	
Supply Voltage V_{CC}	4.5	5.0	5.5	4.75	5.0	5.25	Volts
Operating Free-Air Temperature Range	-55	25	125	0	25	70	°C
Normalized Fan Out from Each Output, N			10			10	U.L.
Width of Clock Pulse, $t_{p(\text{clock})}$ (See Fig. E)	20			20			ns
Width of Clear Pulse, $t_{p(\text{clear})}$ (See Fig. F)	25			25			ns
Input Setup Time, t_{setup} (See Fig. E)	$\geq t_{p(\text{clock})}$			$\geq t_{p(\text{clock})}$			
Input Hold Time, t_{hold}	0			0			

X = package type; F for Flatpak, D for Ceramic Dip, P for Plastic Dip. See Packaging Information Section for packages available on this product.

ELECTRICAL CHARACTERISTICS OVER OPERATING TEMPERATURE RANGE (Unless Otherwise Noted)

SYMBOL	PARAMETER	LIMITS			UNITS	TEST CONDITIONS (Note 1)	TEST FIGURE
		MIN.	TYP. (Note 2)	MAX.			
V_{IH}	Input HIGH Voltage	2.0			Volts	Guaranteed Input HIGH	46 & 47
V_{IL}	Input LOW Voltage			0.8	Volts	Guaranteed Input LOW	46 & 47
V_{OH}	Output HIGH Voltage	2.4	3.5		Volts	$V_{CC} = \text{MIN.}, I_{OH} = -0.4 \text{ mA}$	46
V_{OL}	Output LOW Voltage		0.22	0.4	Volts	$V_{CC} = \text{MIN.}, I_{OL} = 16 \text{ mA}$	47
I_{IH}	Input HIGH Current at J or K			40	μA	$V_{CC} = \text{MAX.}, V_{IN} = 2.4 \text{ V}$	49
				1.0	mA	$V_{CC} = \text{MAX.}, V_{IN} = 5.5 \text{ V}$	49
	Input HIGH Current at Clock or Clear			80	μA	$V_{CC} = \text{MAX.}, V_{IN} = 2.4 \text{ V}$	49
				1.0	mA	$V_{CC} = \text{MAX.}, V_{IN} = 5.5 \text{ V}$	49
I_{IL}	Input LOW Current at J or K			-1.6	mA	$V_{CC} = \text{MAX.}, V_{IN} = 0.4 \text{ V}$	48
	Input LOW Current at Clear or Clock			-3.2	mA	$V_{CC} = \text{MAX.}, V_{IN} = 0.4 \text{ V}$	48
I_{OS}	Output Short Circuit Current (Note 3)	-20		-57	mA	9N73/5473; 9N107/54107 $V_{CC} = \text{MAX.}$	50
		-18		-57	mA	9N73/7473; 9N107/74107 $V_{IN} = 0 \text{ V}$	
I_{CC}	Supply Current		20	40	mA	$V_{CC} = \text{MAX.}$	49

SWITCHING CHARACTERISTICS ($T_A = 25^\circ\text{C}$)

SYMBOL	PARAMETER	LIMITS			UNITS	TEST CONDITIONS	TEST FIGURE
		MIN.	TYP.	MAX.			
f_{max}	Maximum Clock Frequency	15	20		MHz	$V_{CC} = 5.0 \text{ V}$ $C_L = 15 \text{ pF}$ $R_L = 400\Omega$	E
t_{PLH}	Turn Off Delay Clear to Output		16	25	ns		F
t_{PHL}	Turn On Delay Clear to Output		25	40	ns		F
t_{PLH}	Turn Off Delay Clock to Output	10	16	25	ns		E
t_{PHL}	Turn On Delay Clock to Output	10	25	40	ns		E

NOTES:

- (1) For conditions shown as MIN. or MAX., use the appropriate value specified under recommended operating conditions for the applicable device type.
- (2) Typical limits are at $V_{CC} = 5.0 \text{ V}, 25^\circ\text{C}$.
- (3) Not more than one output should be shorted at a time.

DUAL D TYPE EDGE TRIGGERED FLIP-FLOP

DESCRIPTION — The HSTTL/SSI 9H74/54H74, 74H74 is a High Speed Dual, Edge Triggered flip-flop utilizing TTL circuitry to perform D type flip-flop logic. Each flip-flop has individual clear and preset inputs, and also complementary Q and Q outputs.

Information at input D is transferred to the Q output on the positive going edge of the clock pulse. Clock triggering occurs at a voltage level of the clock pulse and is not directly related to the transition time of the positive going pulse. When the clock input is at either the HIGH or LOW level, the D input signal has no effect.

These circuits are fully compatible for use with the Fairchild TTL family. Input clamping diodes are provided to minimize transmission line effects and thereby simplify systems design. Maximum clock frequency is 35 MHz, with a typical power dissipation of 75 mW per flip-flop.

LOGIC AND CONNECTION DIAGRAM

DIP (TOP VIEW)

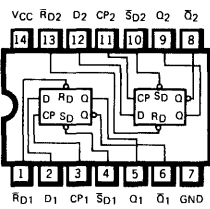

FLATPAK (TOP VIEW)

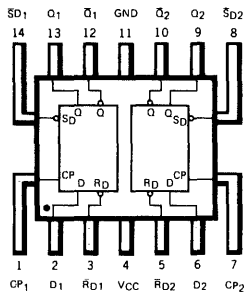

Asynchronous Inputs:
 LOW input to preset sets Q to HIGH level
 LOW input to clear sets Q to LOW level
 Preset and clear are independent of clock

TRUTH TABLE (Each Flip-Flop)

t_n	t_{n+1}	
INPUT D	OUTPUT Q	OUTPUT \bar{Q}
L	L	H
H	H	L

H = HIGH Level, L = LOW Level

NOTES: t_n = bit time before clock pulse.
 t_{n+1} = bit time after clock pulse.

SCHEMATIC DIAGRAM (EACH FLIP-FLOP)

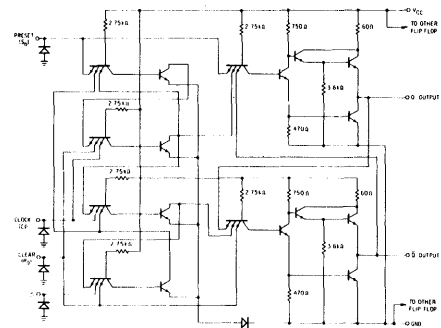

Component values shown are typical.

LOGIC DIAGRAM (EACH FLIP-FLOP)

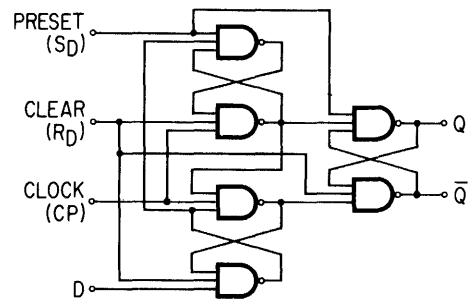

RECOMMENDED OPERATING CONDITIONS

PARAMETER	9H74XM/54H74XM			9H74XC/74H74XC			UNIT
	MIN.	TYP.	MAX.	MIN.	TYP.	MAX.	
Supply Voltage V_{CC}	4.5	5	5.5	4.75	5	5.25	V
Operating Free-Air Temperature Range	-55	25	125	0	25	70	°C
Fan Out from Each Output	LOW Level			12.5			U.L.
	HIGH Level			25			
Clock Frequency, f_{clock}	0		35	0		35	MHz
Width of Clock Pulse, $t_{pw}(clock)$ (See Figure Z or AA)	15			15			ns
Width of Preset pulse, $t_{pw}(preset)$ (See Figure Y)	25			25			ns
Width of Clear Pulse, $t_{pw}(clear)$ (See Figure Y)	25			25			ns
Input Setup Time, t_{setup} (See Note a)	HIGH Level Data (See Figure Z)			10			ns
	LOW Level Data (See Figure AA)			15			
Input Hold Time, t_{hold} (See Note b and Figures Z and AA)	0			0			ns

X = package type; F for Flatpak, D for Ceramic Dip, P for Plastic Dip. See Packaging Information Section for packages available on this product.

NOTES:

- (a) Setup time is the interval immediately preceding the positive going edge of the clock pulse during which interval the data to be recognized must be maintained at the input to ensure its recognition.
- (b) Hold time is the interval immediately following the positive going edge of the clock pulse during which interval the data to be recognized must be maintained at the input to ensure its continued recognition.

FAIRCHILD HIGH SPEED TTL/SSI • 9H74/54H74, 74H74

ELECTRICAL CHARACTERISTICS OVER OPERATING TEMPERATURE RANGE (Unless Otherwise Noted)

SYMBOL	PARAMETER	LIMITS			UNITS	TEST CONDITIONS (Note 1)	TEST FIGURE
		MIN.	TYP. (Note 2)	MAX.			
V _{IH}	Input HIGH Voltage	2.0			Volts	Guaranteed Input HIGH	52 & 53
V _{IL}	Input LOW Voltage			0.8	Volts	Guaranteed Input LOW	52 & 53
V _{OH}	Output HIGH Voltage	2.4	3.5		Volts	V _{CC} = MIN., I _{OH} = -1.0 mA	52
V _{OL}	Output LOW Voltage		0.22	0.4	Volts	V _{CC} = MIN., I _{OL} = 20 mA	53
I _{IH}	Input HIGH Current into D			50	μA	V _{CC} = MAX., V _{IN} = 2.4 V	55
				1.0	mA	V _{CC} = MAX., V _{IN} = 5.5 V	
	Input HIGH Current into Preset or Clock			100	μA	V _{CC} = MAX., V _{IN} = 2.4 V	55
				1.0	mA	V _{CC} = MAX., V _{IN} = 5.5 V	
	Input HIGH Current into Clear into Clear			150	μA	V _{CC} = MAX., V _{IN} = 2.4 V	55
				1.0	mA	V _{CC} = MAX., V _{IN} = 5.5 V	
I _{IL}	Input LOW Current into Preset or D			-2.0	mA	V _{CC} = MAX., V _{IN} = 5.5 V	54
	Input LOW Current into Clear or Clock			-4.0	mA	V _{CC} = MAX., V _{IN} = 0.4 V	54
I _{OS}	Output Short Circuit Current (Note 3)	-40		-100	mA	V _{CC} = MAX., V _{IN} = 0 V	56
I _{CC}	Supply Current		30	42	mA	9H74/54H74	V _{CC} = MAX. 55
			30	50	mA	9H74/74H74	

SWITCHING CHARACTERISTICS (T_A = 25°C)

SYMBOL	PARAMETER	LIMITS			UNITS	TEST CONDITIONS	TEST FIGURE
		MIN.	TYP.	MAX.			
f _{CLOCK}	Maximum Clock Frequency	35	43		MHz	V _{CC} = 5.0 V C _L = 25 pF R _L = 280Ω	Z & AA
t _{PLH}	Turn Off Delay Clear or Preset Inputs to Output			20	ns		Y
t _{PHL}	Turn On Delay Clear or Preset Inputs to Output			30	ns		Y
t _{PLH}	Turn Off Delay Clock Input to Output	4.0	8.5	15	ns		Z & AA
t _{PHL}	Turn On Delay Clock Input to Output	7.0	13	20	ns		Z & AA

NOTES:

- (1) For conditions shown as MIN. or MAX., use the appropriate value specified under recommended operating conditions for the applicable device type.
- (2) Typical limits are at V_{CC} = 5.0 V, 25°C.
- (3) Not more than one output should be shorted at a time, and duration of short-circuit test should not exceed 1 second.

DUAL D TYPE EDGE TRIGGERED FLIP-FLOP

DESCRIPTION — The 9N74/5474, 7474 are edge triggered dual D type flip-flops with direct clear and preset inputs and both Q and \bar{Q} outputs. Information at the input is transferred to the outputs on the positive edge of the clock pulse. They are designed for use in medium to high speed applications.

Clock triggering occurs at a voltage level of the clock pulse and is not directly related to the transition time of the positive going pulse. After the clock input threshold voltage has been passed, the data input (D) is locked out and information present will not be transferred to the output.

The 9N74/5474, 7474 have the same clocking characteristics as the 9N70/5470, 7470 gated (edge triggered) flip-flop circuits. They can result in a significant saving in system power dissipation and package count in applications where input gating is not required.

LOGIC AND CONNECTION DIAGRAM

DIP (TOP VIEW)

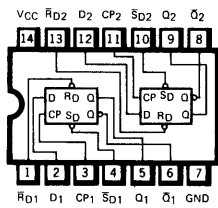

FLATPAK (TOP VIEW)

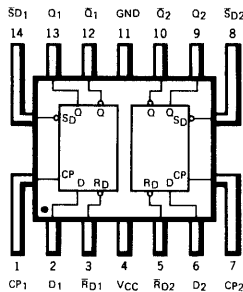

Positive logic:

- LOW input to preset sets Q to HIGH level
- LOW input to clear sets Q to LOW level
- Preset and clear are independent of clock

SCHEMATIC DIAGRAM (EACH FLIP-FLOP)

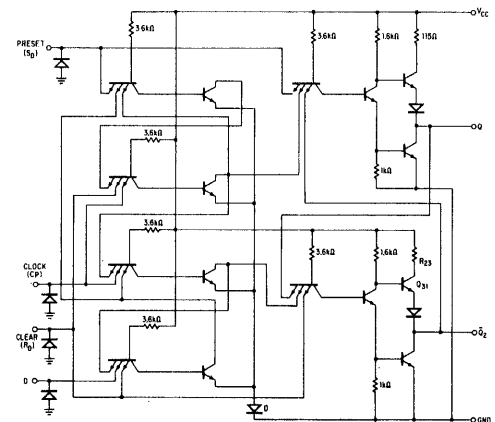

Component values shown are typical.

TRUTH TABLE (Each Flip-Flop)

t_n	t_{n+1}	
INPUT	OUTPUT	OUTPUT
D	Q	\bar{Q}
L	L	H
H	H	L

NOTES:

- t_n = bit time before clock pulse.
- t_{n+1} = bit time after clock pulse.

LOGIC DIAGRAM (EACH FLIP-FLOP)

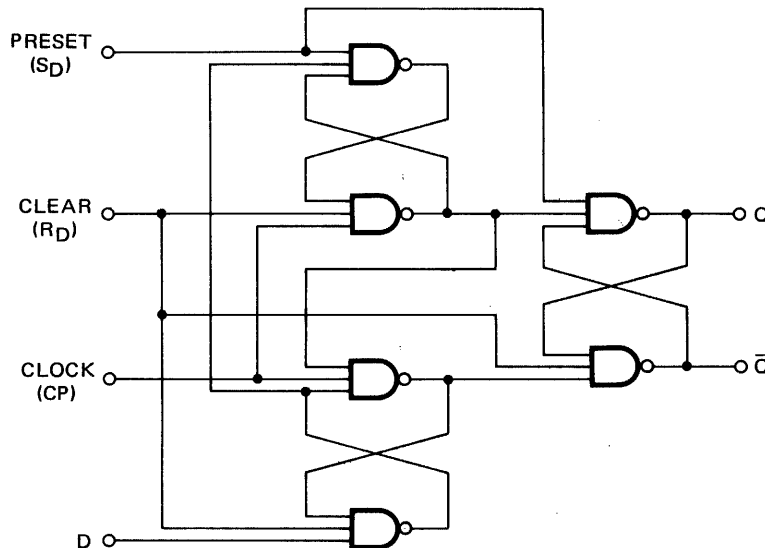

FAIRCHILD TTL/SSI • 9N74/5474, 7474

RECOMMENDED OPERATING CONDITIONS

PARAMETER	9N74XM/5474XM			9N74XC/7474XC			UNITS
	MIN.	TYP.	MAX.	MIN.	TYP.	MAX.	
Supply Voltage V_{CC}	4.5	5.0	5.5	4.75	5.0	5.25	Volts
Operating Free-Air Temperature Range	-55	25	125	0	25	70	°C
Normalized Fan Out from Each Output, N			10			10	U.L.
Width of Clock Pulse, $t_{p(\text{clock})}$ (See Fig. G)	30			30			ns
Width of Preset Pulse, $t_{p(\text{preset})}$ (See Fig. C)	30			30			ns
Width of Clear Pulse, $t_{p(\text{clear})}$ (See Fig. C)	30			30			ns

X = package type; F for Flatpak, D for Ceramic Dip, P for Plastic Dip. See Packaging Information Section for packages available on this product.

ELECTRICAL CHARACTERISTICS OVER OPERATING TEMPERATURE RANGE (Unless Otherwise Noted)

SYMBOL	PARAMETER	LIMITS			UNITS	TEST CONDITIONS (Note 1)	TEST FIGURE
		MIN.	TYP. (Note 2)	MAX.			
V_{IH}	Input HIGH Voltage	2.0			Volts	Guaranteed Input HIGH	52 & 53
V_{IL}	Input LOW Voltage			0.8	Volts	Guaranteed Input LOW	52 & 53
V_{OH}	Output HIGH Voltage	2.4	3.5		Volts	$V_{CC} = \text{MIN.}, I_{OH} = -0.4 \text{ mA}$	52
V_{OL}	Output LOW Voltage		0.22	0.4	Volts	$V_{CC} = \text{MIN.}, I_{OL} = 16 \text{ mA}$	53
I_{IH}	Input HIGH Current at D			40	μA	$V_{CC} = \text{MAX.}, V_{IN} = 2.4 \text{ V}$	55
				1.0	mA	$V_{CC} = \text{MAX.}, V_{IN} = 5.5 \text{ V}$	55
	Input HIGH Current at Preset or Clock			80	μA	$V_{CC} = \text{MAX.}, V_{IN} = 2.4 \text{ V}$	55
				1.0	mA	$V_{CC} = \text{MAX.}, V_{IN} = 5.5 \text{ V}$	55
Input HIGH Current at Clear			120	μA	$V_{CC} = \text{MAX.}, V_{IN} = 2.4 \text{ V}$	55	
			1.0	mA	$V_{CC} = \text{MAX.}, V_{IN} = 5.5 \text{ V}$	55	
I_{IL}	Input LOW Current at Preset or D			-1.6	mA	$V_{CC} = \text{MAX.}, V_{IN} = 0.4 \text{ V}$	54
	Input LOW Current at Clear or Clock			-3.2	mA	$V_{CC} = \text{MAX.}, V_{IN} = 0.4 \text{ V}$	54
I_{OS}	Output Short Circuit Current (Note 3)	-20		-57	mA	9N74/5474 $V_{CC} = \text{MAX.}$	56
		-18		-57	mA	9N74/7474 $V_{IN} = 0 \text{ V}$	
I_{CC}	Supply Current		17	30	mA	$V_{CC} = \text{MAX.}$	55

SWITCHING CHARACTERISTICS ($T_A = 25^\circ\text{C}$)

SYMBOL	PARAMETER	LIMITS			UNITS	TEST CONDITIONS	TEST FIGURE
		MIN.	TYP.	MAX.			
f_{max}	Maximum Clock Frequency	15	25		MHz	$V_{CC} = 5.0 \text{ V}$ $C_L = 15 \text{ pF}$ $R_L = 400\Omega$	G
t_{setup}	Maximum Input Setup Time		15	20	ns		G
t_{hold}	Maximum Input Hold Time		2.0	5.0	ns		G
t_{PLH}	Turn Off Delay Clear or Preset to Output			25	ns		C
t_{PHL}	Turn On Delay Clear or Preset to Output			40	ns		C
t_{PLH}	Turn Off Delay Clock to Output	10	14	25	ns		G
t_{PHL}	Turn On Delay Clock to Output	10	20	40	ns		G

NOTES:

- (1) For conditions shown as MIN. or MAX., use the appropriate value specified under recommended operating conditions for the applicable device type.
- (2) Typical limits are at $V_{CC} = 5.0 \text{ V}, 25^\circ\text{C}$.
- (3) Not more than one output should be shorted at a time.

DUAL D-TYPE EDGE TRIGGERED FLIP-FLOP

DESCRIPTION — The 9S74/54S74, 74S74 dual edge-triggered flip-flops utilize Schottky TTL circuitry to produce very high speed D-type flip-flops. Each flip-flop has individual clear and preset inputs, and also complementary Q and \bar{Q} outputs.

Information at input D is transferred to the Q output on the positive-going edge of the clock pulse. Clock triggering occurs at a voltage level of the clock pulse and is not directly related to the transition time of the positive-going pulse. When the clock input is at either the HIGH or LOW level the D-input signal has no effect.

These circuits are fully compatible for use with most TTL or DTL circuits. Maximum clock frequency is 100 MHz with a typical power dissipation of 66 mW per flip-flop.

**LOGIC AND CONNECTION DIAGRAM
DIP (TOP VIEW)**

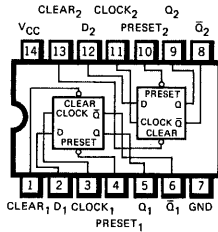

**SYNCHRONOUS
TRUTH TABLE
(EACH FLIP-FLOP)**

t_n	t_{n+1}
INPUT	OUTPUT
D	Q \bar{Q}
L	L H
H	H L

H = HIGH level
L = LOW level
D = Data

**ASYNCHRONOUS
TRUTH TABLE
(EACH FLIP-FLOP)**

INPUT		OUTPUT	
Preset	Clear	Q	\bar{Q}
L	L	H	H
L	H	H	L
H	L	L	H
H	H	No Change	No Change

**LOGIC DIAGRAM
(EACH FLIP-FLOP)**

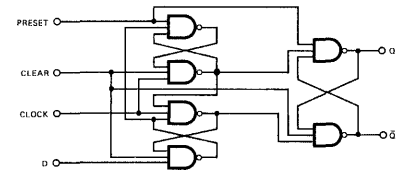

Positive logic: LOW input to preset sets Q to HIGH level
LOW input to clear resets Q to LOW level
Preset and clear are independent of clock

NOTES:
A. t_n = bit time before clock pulse
B. t_{n+1} = bit time after clock pulse

RECOMMENDED OPERATING CONDITIONS

PARAMETER	† 9S74XM/54S74XM			9S74XC/74S74XC			UNITS
	MIN.	TYP.	MAX.	MIN.	TYP.	MAX.	
Supply Voltage V_{CC}	4.5	5.0	5.5	4.75	5.0	5.25	Volts
Operating Free-Air Temperature Range	-55	25	125	0	25	75	°C

X = package type; F for Flatpak, D for Ceramic Dip, P for Plastic Dip. See Packaging Information Section for packages available on this product.

ELECTRICAL CHARACTERISTICS OVER OPERATING TEMPERATURE RANGE (Unless Otherwise Noted)

SYMBOL	PARAMETER	LIMITS			UNITS	TEST CONDITIONS (Note 1)	
		MIN.	TYP. (Note 2)	MAX.			
V_{IH}	Input HIGH Voltage	2.0			Volts	Guaranteed Input HIGH Voltage	
V_{IL}	Input LOW Voltage			0.8	Volts	Guaranteed Input LOW Voltage	
V_{CD}	Input Clamp Diode Voltage		-0.65	-1.2	Volts	$V_{CC} = \text{MIN.}, I_{IN} = -18 \text{ mA}$	
V_{OH}	Output HIGH Voltage	XM	2.5	3.4	Volts	$V_{CC} = \text{MIN.}, I_{OH} = -1.0 \text{ mA}$	
		XC	2.7	3.4			
V_{OL}	Output LOW Voltage		0.35	0.5	Volts	$V_{CC} = \text{MIN.}, I_{OL} = 20 \text{ mA}$	
I_{IH}	Input HIGH Current at	D		1.0	μA	$V_{CC} = \text{MAX.}, V_{IN} = 2.7 \text{ V}$	
		Preset or Clock		2.0			100
		Clear		3.0			150
I_{IL}	Input LOW Current at	D		-1.4	mA	$V_{CC} = \text{MAX.}, V_{IN} = 0.5 \text{ V}$	
		Preset or Clock		-2.8			-4.0
		Clear		-4.2			-6.0
I_{OS}	Output Short Circuit Current (Note 3)	-40	-65	-100	mA	$V_{CC} = \text{MAX.}, V_{OUT} = 0 \text{ V}$	
I_{CC}	Supply Current		30	50	mA	$V_{CC} = \text{MAX.}$ (Note 4)	

NOTES:

- (1) For conditions shown as MIN. or MAX., use the appropriate value specified under recommended operating conditions for the applicable device type.
- (2) Typical limits are at $V_{CC} = 5.0 \text{ V}, 25^\circ\text{C}$.
- (3) Not more than one output should be shorted at a time.
- (4) I_{CC} is measured with clock and data inputs grounded and either preset or clear inputs grounded.

SWITCHING CHARACTERISTICS ($T_A = 25^\circ\text{C}$)

SYMBOL	PARAMETER	LIMITS			UNITS	TEST CONDITIONS
		MIN.	TYP.	MAX.		
f_{max}	Maximum Clock Frequency		100		MHz	$V_{CC} = 5.0\text{ V}$ $C_L = 15\text{ pF}$
t_{PLH}	Turn Off Delay Clear or Preset to Output		4.0		ns	
t_{PHL}	Turn On Delay Clear or Preset to Output		7.0		ns	
t_{PLH}	Turn Off Delay Clock to Output		7.0		ns	
t_{PHL}	Turn On Delay Clock to Output		7.0		ns	

SWITCHING CHARACTERISTICS

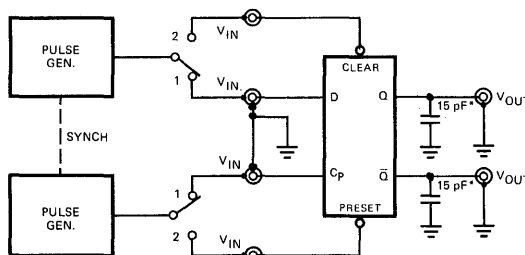

*Includes all probe and jig capacitance.

PULSE GENERATOR SETTINGS

CLOCK	D	DIRECT SET, CLEAR
$f \approx 1\text{ MHz}$	$f \approx 500\text{ kHz}$	$f \approx 1\text{ MHz}$
$t_f = t_r = 2.5\text{ ns}$	$t_f = t_r = 2.5\text{ ns}$	$t_f = t_r = 2.5\text{ ns}$
Amp = 0 to 3 V	Amp = 0 to 3 V	Amp = 0 to 3 V
Duty cycle = 50%	$t_{\text{setup}}(\text{HIGH}) = 5\text{ ns}$	Duty cycle = Adjust pulse width and synch to attain waveforms shown.
	$t_{\text{setup}}(\text{LOW}) = 4\text{ ns}$	
	Duty cycle = Adjust pulse width to attain $t_{\text{setup}}(\text{HIGH})$ and $t_{\text{setup}}(\text{LOW})$ relative to clock as shown in waveforms.	

SWITCHING WAVEFORMS

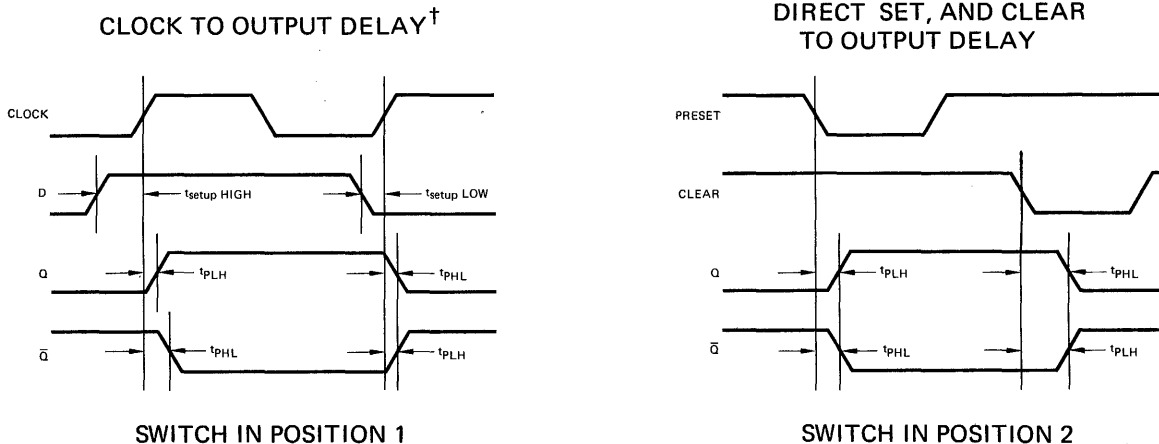

†Direct set and clear inputs connected to V_{CC} thru 2 k Ω resistor during test.

DUAL JK MASTER/SLAVE FLIP-FLOP WITH SEPARATE PRESETS, CLEARS AND CLOCKS

DESCRIPTION – The HSTTL/SSI 9H76/54H76, 74H76 is a High Speed Dual JK Master/Slave flip-flop with separate presets, separate clears and separate clocks. Inputs to the master section are controlled by the clock pulse. The clock pulse also regulates the circuitry which connects the master and slave sections. The sequence of operation is as follows: 1) Isolate slave from master. 2) Enter information from J and K inputs to master. 3) Disable J and K inputs. 4) Transfer information from master to slave. Logic state of J and K inputs must not be allowed to change when the clock pulse is a HIGH state.

LOGIC AND CONNECTION DIAGRAM

DIP (TOP VIEW)

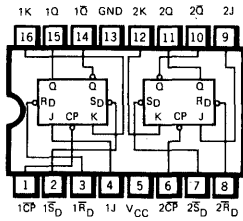

FLATPAK (TOP VIEW)

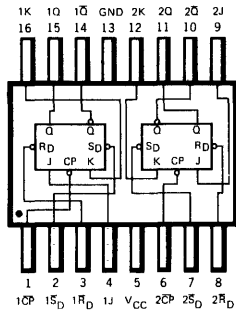

Positive logic:

- LOW input to preset sets Q to HIGH level
- LOW input to clear sets Q to LOW level
- Clear and preset are independent of clock

TRUTH TABLE

t_n		t_{n+1}
J	K	Q
L	L	Q_n
L	H	L
H	L	H
H	H	\bar{Q}_n

NOTES:
 t_n = Bit time before clock pulse.
 t_{n+1} = Bit time after clock pulse.

SCHEMATIC DIAGRAM (EACH FLIP-FLOP)

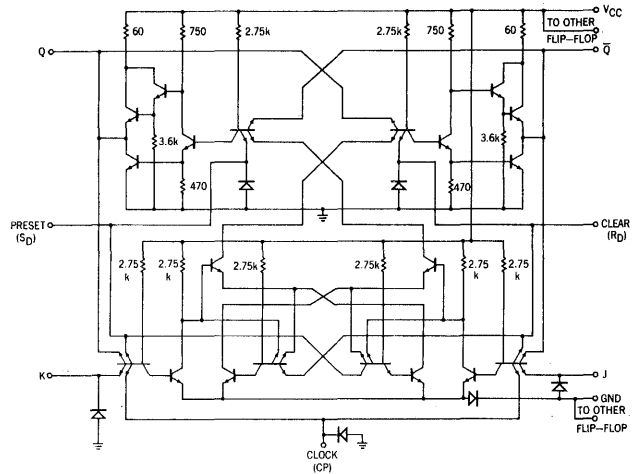

Component values shown are typical.

CLOCK WAVEFORM

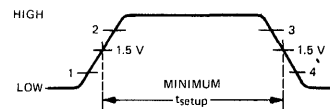

LOGIC DIAGRAM (EACH FLIP-FLOP)

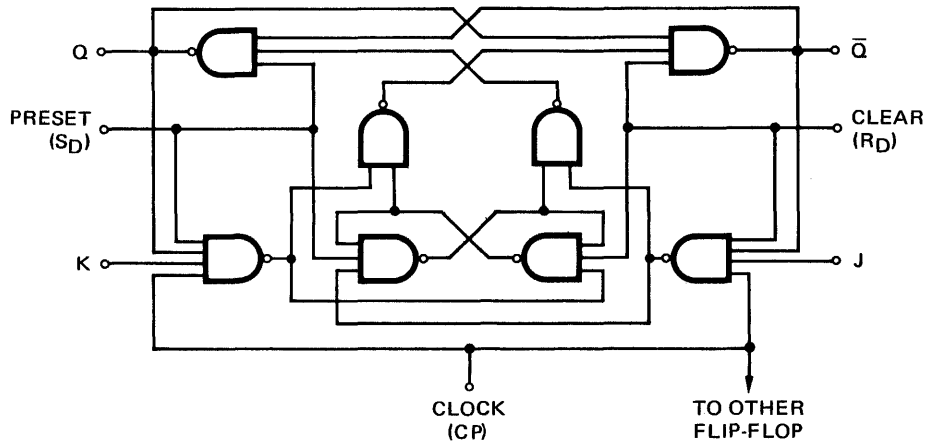

FAIRCHILD HIGH SPEED TTL/SSI • 9H76/54H76, 74H76

RECOMMENDED OPERATING CONDITIONS

PARAMETER	9H76XM/54H76XM			9H76XC/74H76XC			UNITS
	MIN.	TYP.	MAX.	MIN.	TYP.	MAX.	
Supply Voltage V_{CC}	4.5	5.0	5.5	4.75	5.0	5.25	Volts
Operating Free-Air Temperature Range	-55	25	125	0	25	70	°C
Fan Out from Each Output			12.5			12.5	U.L.
Width of Clock Pulse, $t_{p(\text{clock})}$ (See Fig. W)	12			12			ns
Width of Preset Pulse, $t_{p(\text{preset})}$ (See Fig. X)	16			16			ns
Width of Clear Pulse, $t_{p(\text{clear})}$ (See Fig. X)	16			16			ns
Input Setup Time, t_{setup} (See Clock Waveform)	$\geq t_{p(\text{clock})}$			$\geq t_{p(\text{clock})}$			
Input Hold Time, t_{hold}	0			0			

X = package type; F for Flatpak, D for Ceramic Dip, P for Plastic Dip. See Packaging Information Section for packages available on this product.

ELECTRICAL CHARACTERISTICS OVER OPERATING TEMPERATURE RANGE (Unless Otherwise Noted)

SYMBOL	PARAMETER	LIMITS			UNITS	TEST CONDITIONS (Note 1)	TEST FIGURE
		MIN.	TYP. (Note 2)	MAX.			
V_{IH}	Input HIGH Voltage	2.0			Volts	Guaranteed Input HIGH	46 & 47
V_{IL}	Input LOW Voltage			0.8	Volts	Guaranteed Input LOW	46 & 47
V_{OH}	Output HIGH Voltage	2.4			Volts	$V_{CC} = \text{MIN.}, I_{OH} = -0.5 \text{ mA}$	46
V_{OL}	Output LOW Voltage			0.4	Volts	$V_{CC} = \text{MIN.}, I_{OL} = 20 \text{ mA}$	47
I_{IH}	Input HIGH Current at J, K or Clock			50	μA	$V_{CC} = \text{MAX.}, V_{IN} = 2.4 \text{ V}$	126
				1.0	mA	$V_{CC} = \text{MAX.}, V_{IN} = 5.5 \text{ V}$	
	Input HIGH Current at Clear or Preset			100	μA	$V_{CC} = \text{MAX.}, V_{IN} = 2.4 \text{ V}$	126
I_{IL}	Input LOW Current at J, K or Clock			-2.0	mA	$V_{CC} = \text{MAX.}, V_{IN} = 0.4 \text{ V}$	125
	Input LOW Current at Clear or Preset			-4.0	mA	$V_{CC} = \text{MAX.}, V_{IN} = 0.4 \text{ V}$	125
I_{OS}	Output Short Circuit Current (Note 3)	-40		-100	mA	$V_{CC} = \text{MAX.}, V_{IN} = 0$	50
I_{CC}	Supply Current		32	50	mA	$V_{CC} = \text{MAX.}, V_{IN} = 4.5 \text{ V}$	126

SWITCHING CHARACTERISTICS ($T_A = 25^\circ\text{C}$)

SYMBOL	PARAMETER	LIMITS			UNITS	TEST CONDITIONS	TEST FIGURE
		MIN.	TYP.	MAX.			
f_{CLOCK}	Maximum Clock Frequency	25	30		MHz	$V_{CC} = 5.0 \text{ V}$ $C_L = 25 \text{ pF}$ $R_L = 280 \Omega$	W
t_{PLH}	Turn Off Delay Clear or Preset to Output		6.0	13	ns		X
t_{PHL}	Turn On Delay Clear or Preset to Output		12	24	ns		X
t_{PLH}	Turn Off Delay Clock to Output	6.0	14	21	ns		W
t_{PHL}	Turn on Delay Clock to Output	10	22	27	ns		W

NOTES:

- (1) For conditions shown as MIN. or MAX., use the appropriate value specified under recommended operating conditions for the applicable device type.
- (2) Typical limits are at $V_{CC} = 5.0 \text{ V}, 25^\circ\text{C}$.
- (3) Not more than one output should be shorted at a time, and duration of short-circuit test should not exceed 1 second.

5

DUAL JK MASTER/SLAVE FLIP-FLOP WITH SEPARATE PRESETS, CLEARS AND CLOCKS

DESCRIPTION — The TTL/SSI 9N76/5476, 7476 is a Dual JK Master/Slave flip-flop with separate presets, separate clears and separate clocks. Inputs to the master section are controlled by the clock pulse. The clock pulse also regulates the state of the coupling transistors which connect the master and slave sections. The sequence of operation is as follows: 1) Isolate slave from master. 2) Enter information from J and K inputs to master. 3) Disable J and K inputs. 4) Transfer information from master to slave.

LOGIC AND CONNECTION DIAGRAM

DIP (TOP VIEW)

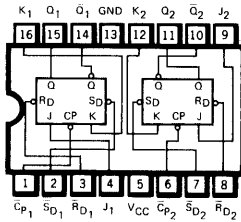

FLATPAK (TOP VIEW)

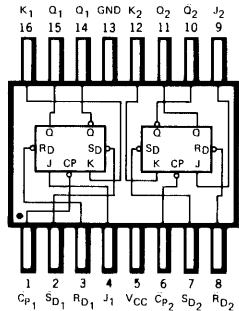

Positive logic:
 LOW input to preset sets Q to HIGH level
 LOW input to clear sets Q to LOW level
 Clear and preset are independent of clock

SCHEMATIC DIAGRAM (EACH FLIP-FLOP)

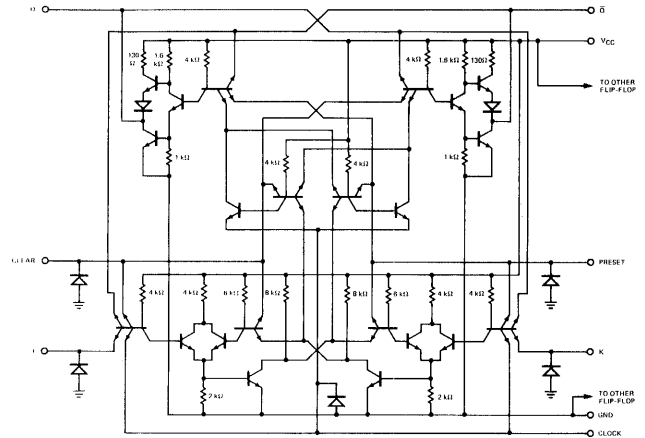

Component values shown are typical.

TRUTH TABLE

t_n		t_{n+1}
J	K	Q
L	L	Q_n
L	H	L
H	L	H
H	H	\bar{Q}_n

NOTES:
 t_n = Bit time before clock pulse.
 t_{n+1} = Bit time after clock pulse.

CLOCK WAVEFORM



LOGIC DIAGRAM (EACH FLIP-FLOP)

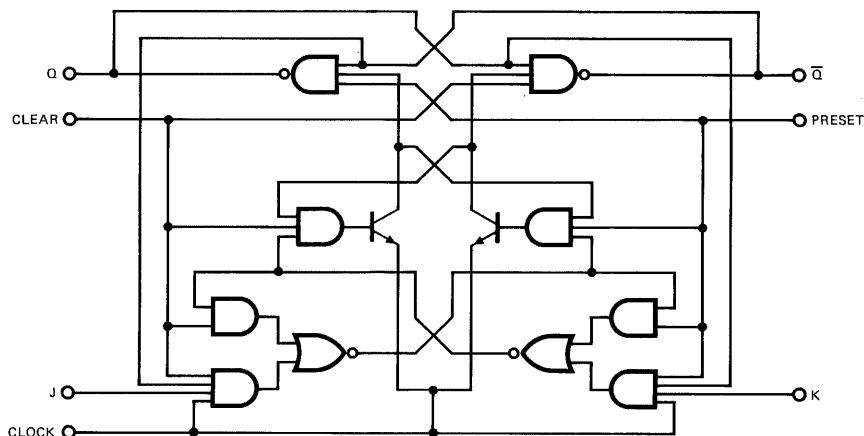

FAIRCHILD TTL/SSI • 9N76/5476, 7476

RECOMMENDED OPERATING CONDITIONS

PARAMETER	9N76XM/5476XM			9N76XC/7476XC			UNITS
	MIN.	TYP.	MAX.	MIN.	TYP.	MAX.	
Supply Voltage V_{CC}	4.5	5.0	5.5	4.75	5.0	5.25	Volts
Operating Free-Air Temperature Range	-55	25	125	0	25	70	°C
Normalized Fan Out from Each Output, N			10			10	U.L.
Width of Clock Pulse, $t_{p(\text{clock})}$ (See Fig. E)	20			20			ns
Width of Preset Pulse, $t_{p(\text{preset})}$ (See Fig. F)	25			25			ns
Width of Clear Pulse, $t_{p(\text{clear})}$ (See Fig. F)	25			25			ns
Input Setup Time, t_{setup} (See Fig. E)	$\geq t_{p(\text{clock})}$			$\geq t_{p(\text{clock})}$			
Input Hold Time, t_{hold}	0			0			

X = package type; F for Flatpak, D for Ceramic Dip, P for Plastic Dip. See Packaging Information Section for packages available on this product.

ELECTRICAL CHARACTERISTICS OVER OPERATING TEMPERATURE RANGE (Unless Otherwise Noted)

SYMBOL	PARAMETER	LIMITS			UNITS	TEST CONDITIONS (Note 1)	TEST FIGURE
		MIN.	TYP. (Note 2)	MAX.			
V_{IH}	Input HIGH Voltage	2.0			Volts	Guaranteed Input HIGH	46 & 47
V_{IL}	Input LOW Voltage			0.8	Volts	Guaranteed Input LOW	46 & 47
V_{OH}	Output HIGH Voltage	2.4	3.5		Volts	$V_{CC} = \text{MIN.}, I_{OH} = -0.4 \text{ mA}$	46
V_{OL}	Output LOW Voltage		0.22	0.4	Volts	$V_{CC} = \text{MIN.}, I_{OL} = 16 \text{ mA}$	47
I_{IH}	Input HIGH Current at J or K			40	μA	$V_{CC} = \text{MAX.}, V_{IN} = 2.4 \text{ V}$	49
				1.0	mA	$V_{CC} = \text{MAX.}, V_{IN} = 5.5 \text{ V}$	
I_{IL}	Input HIGH Current at Clear, Preset or Clock			80	μA	$V_{CC} = \text{MAX.}, V_{IN} = 2.4 \text{ V}$	49
				1.0	mA	$V_{CC} = \text{MAX.}, V_{IN} = 5.5 \text{ V}$	
I_{IL}	Input LOW Current at J or K			-1.6	mA	$V_{CC} = \text{MAX.}, V_{IN} = 0.4 \text{ V}$	48
	Input LOW Current at Clear, Preset, or Clock			-3.2	mA	$V_{CC} = \text{MAX.}, V_{IN} = 0.4 \text{ V}$	48
I_{OS}	Output Short Circuit Current (Note 3)	-20		-57	mA	9N76/5476 $V_{CC} = \text{MAX.}$	51
		-18		-57	mA	9N76/7476 $V_{IN} = 0 \text{ V}$	
I_{CC}	Supply Current		20	40	mA	$V_{CC} = \text{MAX.}$	49

SWITCHING CHARACTERISTICS ($T_A = 25^\circ\text{C}$)

SYMBOL	PARAMETER	LIMITS			UNITS	TEST CONDITIONS	TEST FIGURE
		MIN.	TYP.	MAX.			
f_{max}	Maximum Clock Frequency	15	20		MHz	$V_{CC} = 5.0 \text{ V}$ $C_L = 15 \text{ pF}$ $R_L = 400\Omega$	E
t_{PLH}	Turn Off Delay Clear or Preset to Output		16	25	ns		F
t_{PHL}	Turn On Delay Clear or Preset to Output		25	40	ns		F
t_{PLH}	Turn Off Delay Clock to Output	10	16	25	ns		E
t_{PHL}	Turn On Delay Clock to Output	10	25	40	ns		E

NOTES:

- (1) For conditions shown as MIN. or MAX., use the appropriate value specified under recommended operating conditions for the applicable device type.
- (2) Typical limits are at $V_{CC} = 5.0 \text{ V}, 25^\circ\text{C}$.
- (3) Note more than one output should be shorted at a time.

DUAL JK MASTER/SLAVE FLIP-FLOP WITH SEPARATE PRESETS, AND A COMMON CLEAR AND CLOCK

DESCRIPTION — The HSTTL/SSI 9H78/54H78, 74H78 is a High Speed Dual JK Master/Slave flip-flop with separate presets, a common clear and a common clock. Inputs to the master section are controlled by the clock pulse. The clock pulse also regulates the circuitry which connects the master and slave sections. The sequence of operation is as follows: 1) Isolate slave from master. 2) Enter information from J and K inputs to master. 3) Disable J and K inputs. 4) Transfer information from master to slave. Logic state of J and K inputs must not be allowed to change when the clock pulse is in a HIGH state.

LOGIC AND CONNECTION DIAGRAM

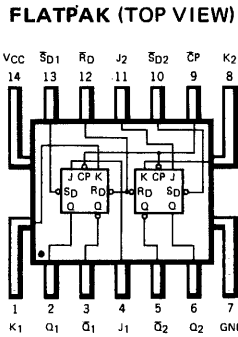
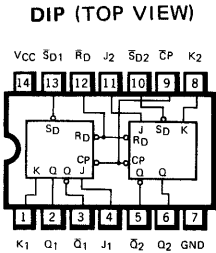

Positive logic:
 LOW input to preset sets Q to HIGH level
 LOW input to clear sets Q to LOW level
 Preset and clear are independent of clock

TRUTH TABLE

t_n		t_{n+1}
J	K	Q
L	L	Q_n
L	H	L
H	L	H
H	H	\bar{Q}_n

NOTES:
 t_n = Bit time before clock pulse.
 t_{n+1} = Bit time after clock pulse.

SCHMATIC DIAGRAM (EACH FLIP FLOP)

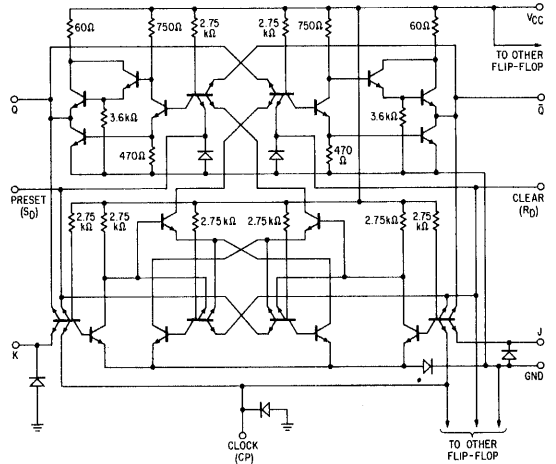

Component values shown are typical.

CLOCK WAVEFORM

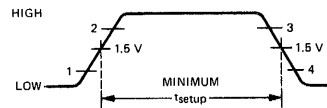

LOGIC DIAGRAM (EACH FLIP-FLOP)

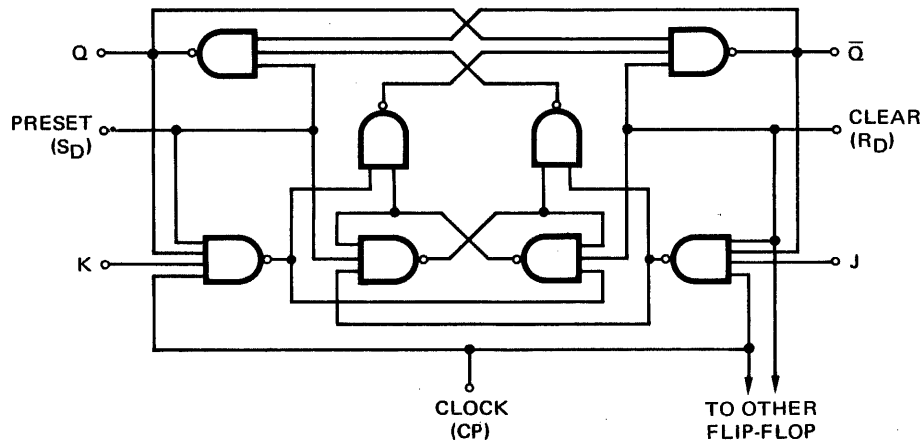

FAIRCHILD HIGH SPEED TTL/SSI • 9H78/54H78, 74H78

RECOMMENDED OPERATING CONDITIONS

PARAMETER	9H78XM/54H78XM			9H78XC/74H78XC			UNITS
	MIN.	TYP.	MAX.	MIN.	TYP.	MAX.	
Supply Voltage V_{CC}	4.5	5.0	5.5	4.75	5.0	5.25	Volts
Operating Free-Air Temperature Range	-55	25	125	0	25	70	°C
Fan Out from Each Output			12.5			12.5	U.L.
Width of Clock Pulse, $t_{p(\text{clock})}$ (See Fig. W)	12			12			ns
Width of Preset Pulse, $t_{p(\text{preset})}$ (See Fig. X)	16			16			ns
Width of Clear Pulse, $t_{p(\text{clear})}$ (See Fig. X)	16			16			ns
Input Setup Time, t_{setup} (See Clock Waveform)	$\geq t_{p(\text{clock})}$			$\geq t_{p(\text{clock})}$			
Input Hold Time, t_{hold}	0			0			

X = package type; F for Flatpak, D for Ceramic Dip, P for Plastic Dip. See Packaging Information Section for packages available on this product.

ELECTRICAL CHARACTERISTICS OVER OPERATING TEMPERATURE RANGE (Unless Otherwise Noted)

SYMBOL	PARAMETER	LIMITS			UNITS	TEST CONDITIONS (Note 1)	TEST FIGURE
		MIN.	TYP. (Note 2)	MAX.			
V_{IH}	Input HIGH Voltage	2.0			Volts	Guaranteed Input HIGH Voltage	46 & 47
V_{IL}	Input LOW Voltage			0.8	Volts	Guaranteed Input LOW Voltage	46 & 47
V_{OH}	Output HIGH Voltage	2.4			Volts	$V_{CC} = \text{MIN.}, I_{OH} = -0.5 \text{ mA}$	46
V_{OL}	Output LOW Voltage			0.4	Volts	$V_{CC} = \text{MIN.}, I_{OL} = 20 \text{ mA}$	47
I_{IH}	Input HIGH Current at J or K			50	μA	$V_{CC} = \text{MAX.}, V_{IN} = 2.4 \text{ V}$	126
				1.0	mA	$V_{CC} = \text{MAX.}, V_{IN} = 5.5 \text{ V}$	
	Input HIGH Current at Preset or Clock			100	μA	$V_{CC} = \text{MAX.}, V_{IN} = 2.4 \text{ V}$	126
				1.0	mA	$V_{CC} = \text{MAX.}, V_{IN} = 5.5 \text{ V}$	
I_{IL}	Input LOW Current at J or K			200	μA	$V_{CC} = \text{MAX.}, V_{IN} = 2.4 \text{ V}$	126
				1.0	mA	$V_{CC} = \text{MAX.}, V_{IN} = 5.5 \text{ V}$	
	Input LOW Current at Preset or Clock			-2.0	mA	$V_{CC} = \text{MAX.}, V_{IN} = 0.4 \text{ V}$	
Input LOW Current at Clear				-4.0	mA	$V_{CC} = \text{MAX.}, V_{IN} = 0.4 \text{ V}$	125
				-8.0	mA	$V_{CC} = \text{MAX.}, V_{IN} = 0.4 \text{ V}$	125
I_{OS}	Output Short Circuit Current (Note 3)	-40		-100	mA	$V_{CC} = \text{MAX.}, V_{IN} = 0\text{V}$	51
I_{CC}	Supply Current		32	50	mA	$V_{CC} = \text{MAX.}$	126

SWITCHING CHARACTERISTICS ($T_A = 25^\circ\text{C}$)

SYMBOL	PARAMETER	LIMITS			UNITS	TEST CONDITIONS	TEST FIGURE
		MIN.	TYP.	MAX.			
f_{CLOCK}	Maximum Clock Frequency	25	30		MHz	$V_{CC} = 5.0 \text{ V}$ $C_L = 25 \text{ pF}$ $R_L = 280\Omega$	W
t_{PLH}	Turn Off Delay Clear to Output		6	13	ns		X
t_{PHL}	Turn On Delay Clear to Output		12	24	ns		X
t_{PLH}	Turn On Delay Clock to Output	6.0	14	21	ns		W
t_{PHL}	Turn On Delay Clock to Output	10	22	27	ns		W

NOTES:

- (1) For conditions shown as MIN. or MAX., use the appropriate value specified under recommended operating conditions for the applicable device type.
- (2) Typical limits are at $V_{CC} = 5.0 \text{ V}, 25^\circ\text{C}$.
- (3) Not more than one output should be shorted at a time, and duration of short-circuit test should not exceed 1 second.

LPTTL/SSI 9L86

LOW POWER QUAD EXCLUSIVE OR GATE

DESCRIPTION – The Low Power TTL/SSI 9L86 consists of four Exclusive OR Gates. Designed for low power, medium speed operation, the 9L86 is useful in large number of code conversion, parity generation/checking and comparison applications. The exclusive OR gate produces an output when the inputs are complementary. The Boolean expression for the device is: $Z = A\bar{B} + \bar{A}B$.

- TYPICAL PROPAGATION DELAY OF 25 ns
- TYPICAL POWER DISSIPATION OF 25 mW
- INPUT CLAMP DIODES LIMIT HIGH SPEED TERMINATION EFFECTS
- ALL CERAMIC "HERMETIC" 14-LEAD DUAL IN-LINE AND FLAT PACKAGES
- TTL COMPATIBLE

PIN NAMES

INPUTS (Pins 1, 2, 4, 5, 9, 10, 12, 13)
 OUTPUTS (Pins 3, 6, 8, 11)

LOADING	
HIGH	LOW
0.75 U.L.	0.38 U.L.
10 U.L.	2.5 U.L.

1 Unit Load (U.L.) = 40 μ A HIGH/1.6 mA LOW.

SCHEMATIC DIAGRAM

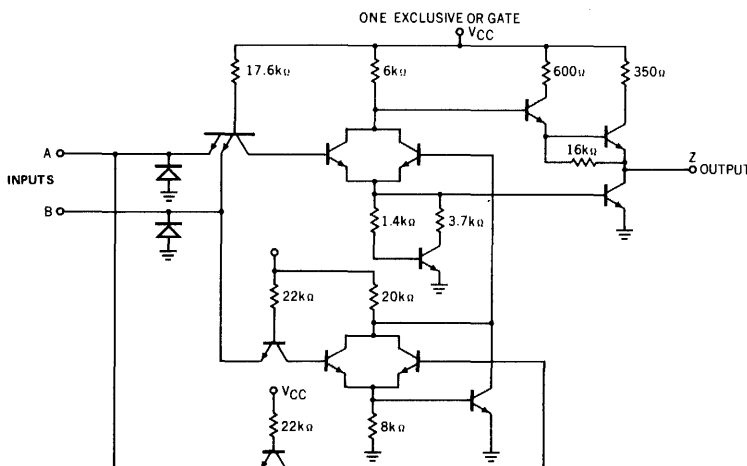

LOGIC SYMBOL

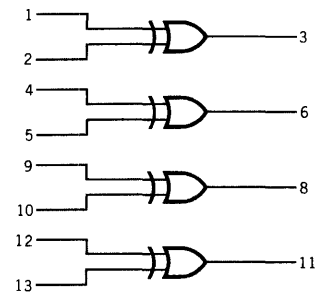

V_{CC} = PIN 14
 GND = PIN 7

CONNECTION DIAGRAMS DIP (TOP VIEW)

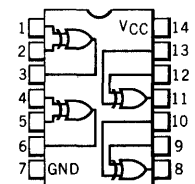

FLATPAK (TOP VIEW)

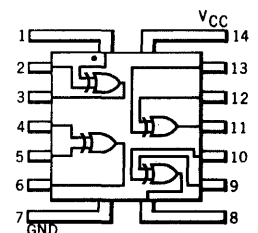

FAIRCHILD LPTTL/SSI • 9L86

ABSOLUTE MAXIMUM RATINGS (above which the useful life may be impaired)

Storage Temperature	-65°C to +150°C
Temperature (Ambient) Under Bias	-55°C to +125°C
V _{CC} Pin Potential to Ground Pin	-0.5 V to +7.0 V
*Input Voltage (dc)	-0.5 V to +5.5 V
*Input Current (dc)	-30 mA to +5.0 mA
Voltage Applied to Outputs (Output HIGH)	-0.5 V to +V _{CC} value
Output Current (dc) (Output LOW)	+30 mA

*Either Input Voltage limit or Input Current limit is sufficient to protect the inputs.

GUARANTEED OPERATING RANGES

PART NUMBER	SUPPLY VOLTAGE (V _{CC})			TEMPERATURE
	MIN.	TYP.	MAX.	
9L86XM	4.5 V	5.0 V	5.5 V	-55°C to 125°C
9L86XC	4.75 V	5.0 V	5.25 V	0°C to 75°C

X = package type; F for Flatpak, D for Ceramic Dip, P for Plastic Dip. See Packaging Information Section for packages available on this product.

ELECTRICAL CHARACTERISTICS OVER OPERATING TEMPERATURE RANGE (Unless Otherwise Noted) (See Notes 1, 2 & 3)

SYMBOL	PARAMETER	LIMITS			UNITS	CONDITIONS
		MIN.	TYP. Note 3	MAX.		
V _{OH}	Output HIGH Voltage	2.4	3.6		Volts	V _{CC} = MIN., I _{OH} = -0.4 mA, V _{IN} = V _{IL} or V _{IH} per Truth Table
V _{OL}	Output LOW Voltage		0.1	0.3	Volts	V _{CC} = MIN., I _{OL} = 4.0 mA, V _{IN} = V _{IH} or V _{IL} per Truth Table
V _{IH}	Input HIGH Voltage	2.0			Volts	Guaranteed input HIGH voltage for all inputs
V _{IL}	Input LOW Voltage			0.7	Volts	Guaranteed input LOW voltage for all inputs
I _{IL}	Input LOW Current		-0.48	-0.6	mA	V _{CC} = MAX., V _{IN} = 0.3 V, other input = 4.5 V
I _{IH}	Input HIGH Current		6.0	30	μA	V _{CC} = MAX., V _{IN} = 2.4 V
				1.0	mA	V _{CC} = MAX., V _{IN} = 5.5 V
I _{SC} *	Output Short Circuit Current	-10	-22	-40	mA	V _{CC} = MAX., V _{OUT} = 0.0 V, "A" inputs = 0.0 V, "B" inputs = 4.5 V
I _{CC}	Power Supply Current		6.8	9.5	mA	V _{CC} = MAX., All inputs = 0.0 V
			3.4	5.0	mA	V _{CC} = MAX., "A" inputs = 4.5 V, "B" inputs = 0.0 V
			6.3	9.0	mA	V _{CC} = MAX., All inputs = 4.5 V

- NOTES: 1. Conditions for testing, not shown in the Table, are chose to guarantee operation under "worst case" conditions.
 2. The specified LIMITS represent the "worst case" value for the parameter. Since these "worst case" values normally occur at the temperature and supply voltage extremes, additional noise immunity and guard banding can be achieved by decreasing the allowable system operating ranges.
 3. Typical limits are at V_{CC} = 5.0 V, 25°C, and max. loading.

* Not more than one output should be shorted at a time.

SWITCHING CHARACTERISTICS (T_A = 25°C)

SYMBOL	PARAMETER	9L86XM			9L86XC			UNITS	CONDITIONS	
		MIN.	TYP.	MAX.	MIN.	TYP.	MAX.			
t _{PLH}	Switching Times	8	15	20	8	15	25	ns	V _{IN1} = 5.0 V	V _{CC} = 5.0 V, C _L = 15 pF
t _{PHL}		10	25	35	10	25	40			
t _{PHH}	Switching Times	12	25	40	12	25	40	ns	V _{IN1} = 0.0 V	
t _{PLL}		20	35	45	20	35	50			

SWITCHING TIME WAVEFORMS

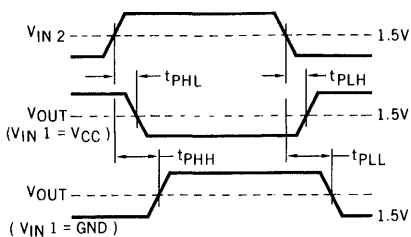

TRUTH TABLE

A	B	Z
L	L	L
L	H	H
H	L	H
H	H	L

QUAD 2-INPUT EXCLUSIVE OR GATE

DESCRIPTION — The TTL/SSI 9N86/5486, 7486 is a Quad 2-input Exclusive OR gate designed to perform the function: $Y = A\bar{B} + \bar{A}B$. When the input states are complementary, the output goes to the HIGH level.

Input clamping diodes are provided to minimize transmission line effects. On chip input buffers are also provided to lower the fan in requirement to only 1 U.L. (unit load). The 9N86/5486, 7486 is fully compatible with all members of the Fairchild TTL family.

LOGIC AND CONNECTION DIAGRAM

DIP (TOP VIEW)

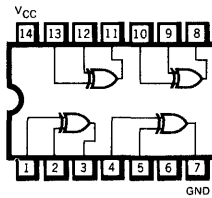

FLATPAK (TOP VIEW)

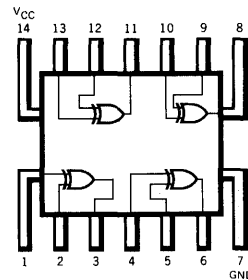

TRUTH TABLE

INPUTS		OUTPUT
A	B	Y
L	L	L
L	H	H
H	L	H
H	H	L

Positive logic: $Y = A \oplus B$

SCHEMATIC DIAGRAM

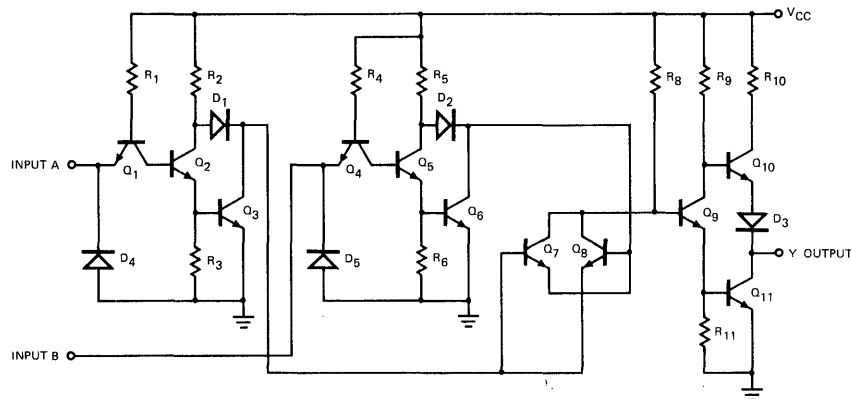

1/4 of Circuit shown.

FAIRCHILD TTL/SSI • 9N86/5486, 7486

RECOMMENDED OPERATING CONDITIONS

PARAMETER	9N86XM/5486XM			9N86XC/7486XC			UNITS
	MIN.	TYP.	MAX.	MIN.	TYP.	MAX.	
Supply Voltage V_{CC}	4.5	5.0	5.5	4.75	5.0	5.25	Volts
Operating Free-Air Temperature Range	-55	25	125	0	25	70	°C
Normalized Fan Out from Each Output N	LOW Level		10			10	U.L.
	HIGH Level		20			20	U.L.

X = package type; F for Flatpak, D for Ceramic Dip, P for Plastic Dip. See Packaging Information Section for packages available on this product.

ELECTRICAL CHARACTERISTICS OVER OPERATING TEMPERATURE RANGE (Unless Otherwise Noted)

SYMBOL	PARAMETER	LIMITS			UNITS	TEST CONDITIONS (Note 1)	TEST FIGURE
		MIN.	TYP. (Note 2)	MAX.			
V_{IH}	Input HIGH Voltage	2.0			Volts	Guaranteed Input HIGH Voltage	98
V_{IL}	Input LOW Voltage			0.8	Volts	Guaranteed Input LOW Voltage	98
V_{OH}	Output HIGH Voltage	2.4			Volts	$V_{CC} = \text{MIN.}, I_{OH} = -800 \mu\text{A}, V_{IH} = 2.0 \text{ V}, V_{IL} = 0.8 \text{ V}$	98
V_{OL}	Output LOW Voltage			0.4	Volts	$V_{CC} = \text{MIN.}, I_{OL} = 16 \text{ mA}, V_{IH} = 2.0 \text{ V}, V_{IL} = 0.8 \text{ V}$	99
I_{IH}	Input HIGH Current			40	μA	$V_{CC} = \text{MAX.}, V_{IN} = 2.4 \text{ V}$ (Each Input)	100
				1.0	mA		
I_{IL}	Input LOW Current			-1.6	mA	$V_{CC} = \text{MAX.}, V_{IN} = 0.4 \text{ V}$ (Each Input)	101
I_{OS}	Output Short Circuit Current (Note 3)	-20		-55	mA	9N86/5486 $V_{CC} = \text{MAX.}, V_{IH} = 4.5 \text{ V}$	102
		-18		-55	mA	9N86/7486 $V_{IL} = 0 \text{ V}$	
I_{CC}	Supply Current		30	43	mA	9N86/5486 $V_{CC} = \text{MAX.}, V_{IN} = 4.5 \text{ V}$	103
			30	50	mA	9N86/7486	

SWITCHING CHARACTERISTICS ($T_A = 25^\circ\text{C}$)

SYMBOL	PARAMETER	LIMITS			UNITS	TEST CONDITIONS	TEST FIGURE	
		MIN.	TYP.	MAX.				
t_{PLH}	Turn Off Delay Input to Output		15	23	ns	Other Input Low	$V_{CC} = 5.0 \text{ V}$ $C_L = 15 \text{ pF}$ $R_L = 400\Omega$	S
			18	30		Other Input High		
t_{PHL}	Turn On Delay Input to Output		11	17		Other Input Low		
			13	22		Other Input High		

NOTES:

- (1) For conditions shown as MIN. or MAX., use the appropriate value specified under recommended operating conditions for the applicable device type.
- (2) Typical limits are at $V_{CC} = 5.0 \text{ V}, 25^\circ\text{C}$.
- (3) Not more than one output should be shorted at a time.

JK EDGE TRIGGERED FLIP-FLOP WITH AND-OR INPUTS

DESCRIPTION — The HSTTL/SSI 9H101/54H101, 74H101 is a High Speed JK Negative Edge Triggered flip-flop. The AND-OR gate inputs are inhibited while the clock input is LOW; when the clock goes HIGH, the inputs are enabled and data will be accepted. Logic state of J and K inputs may be allowed to change when the clock pulse is in a HIGH state and bistable will perform according to the truth table as long as minimum set up times are observed. Input data is transferred to the outputs on the negative edge of the clock pulse.

LOGIC AND CONNECTION DIAGRAM

DIP (TOP VIEW)

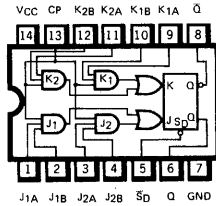

FLATPAK (TOP VIEW)

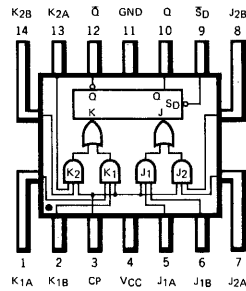

Positive logic:

LOW input to preset sets Q to HIGH level
Preset is independent of clock

SCHEMATIC DIAGRAM

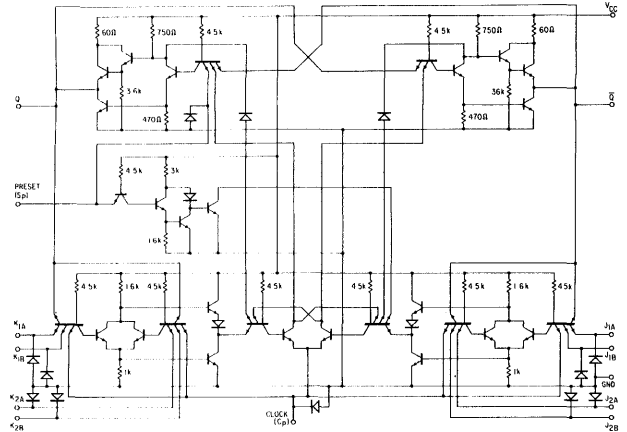

TRUTH TABLE

t_n		t_{n+1}
J	K	Q
L	L	Q_n
L	H	L
H	L	H
H	H	Q_n

NOTES:

- J = $(J1A \cdot J1B) + (J2A \cdot J2B)$
- K = $(K1A \cdot K1B) + (K2A \cdot K2B)$
- t_n = Bit time before clock
- t_{n+1} = Bit time after clock pulse

CLOCK WAVEFORM

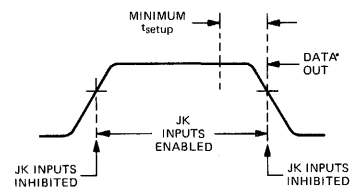

LOGIC DIAGRAM

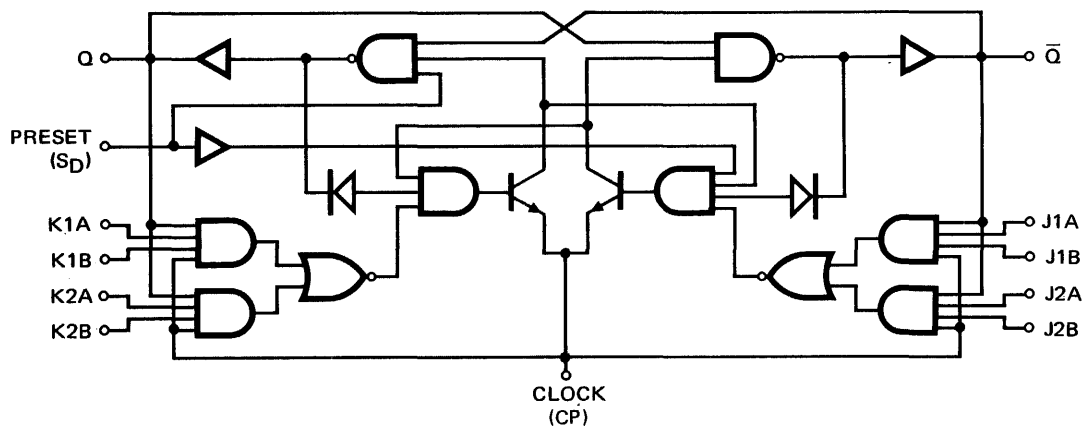

FAIRCHILD HIGH SPEED TTL/SSI • 9H101/54H101, 74H101

RECOMMENDED OPERATING CONDITIONS

PARAMETER	9H101XM/54H101XM			9H101XC/74H101XC			UNITS
	MIN.	TYP.	MAX.	MIN.	TYP.	MAX.	
Supply Voltage V_{CC}	4.5	5.0	5.5	4.75	5.0	5.25	Volts
Operating Free-Air Temperature Range	-55	25	125	0	25	70	°C
Fan Out from Each Output			12.5			12.5	U.L.
Width of Clock Pulse, $t_{p(\text{clock})}$ (See Fig. W)	10			10			ns
Width of Preset Pulse, $t_{p(\text{preset})}$ (See Fig. X)	16			16			ns
Input Setup Time, t_{setup} (See Clock Waveform)	LOW Level	13		13			ns
	HIGH Level	10		10			
Input Hold Time, t_{hold}	0			0			
Clock Pulse Transition Time, t_0 (See Fig. W)			150			150	ns

X = package type; F for Flatpak, D for Ceramic Dip, P for Plastic Dip. See Packaging Information Section for packages available on this product.

ELECTRICAL CHARACTERISTICS OVER OPERATING TEMPERATURE RANGE (Unless Otherwise Noted)

SYMBOL	PARAMETER	LIMITS			UNITS	TEST CONDITIONS (Note 1)	TEST FIGURE
		MIN.	TYP. (Note 2)	MAX.			
V_{IH}	Input HIGH Voltage	2.0			Volts	Guaranteed Input HIGH	121&122
V_{IL}	Input LOW Voltage			0.8	Volts	Guaranteed Input LOW	121&122
V_{OH}	Output HIGH Voltage	2.4	3.2		Volts	$V_{CC} = \text{MIN.}, I_{OH} = -0.5 \text{ mA}$	121
V_{OL}	Output LOW Voltage		0.25	0.4	Volts	$V_{CC} = \text{MIN.}, I_{OL} = 20 \text{ mA}$	122
I_{IH}	Input HIGH Current at J or K			50	μA	$V_{CC} = \text{MAX.}, V_{IN} = 2.4 \text{ V}$	124
				1.0	mA	$V_{CC} = \text{MAX.}, V_{IN} = 5.5 \text{ V}$	
	Input HIGH Current at Preset			100	μA	$V_{CC} = \text{MAX.}, V_{IN} = 2.4 \text{ V}$	124
				1.0	mA	$V_{CC} = \text{MAX.}, V_{IN} = 5.5 \text{ V}$	
Input HIGH Current at Clock		0		-1.0	mA	$V_{CC} = \text{MAX.}, V_{IN} = 2.4 \text{ V}$	124
				1.0	mA	$V_{CC} = \text{MAX.}, V_{IN} = 5.5 \text{ V}$	
I_{IL}	Input LOW Current at J1A, J1B, J2A, J2B, K1A, K1B, K2A, K2B, or Preset		-1.0	-2.0	mA	$V_{CC} = \text{MAX.}, V_{IN} = 0.4 \text{ V}$	123
	Input LOW Current at Clock		-3.0	-4.8	mA	$V_{CC} = \text{MAX.}, V_{IN} = 0.4 \text{ V}$	123
I_{OS}	Output Short Circuit Current (Note 3)	-40		-100	mA	$V_{CC} = \text{MAX.}, V_{IN} = 0 \text{ V}$	127
I_{CC}	Supply Current		20	38	mA	$V_{CC} = \text{MAX.}$	124

SWITCHING CHARACTERISTICS ($T_A = 25^\circ\text{C}$)

SYMBOL	PARAMETER	LIMITS			UNITS	TEST CONDITIONS	TEST FIGURE
		MIN.	TYP.	MAX.			
f_{CLOCK}	Maximum Clock Frequency	40	50		MHz	$V_{CC} = 5.0 \text{ V}$ $C_L = 25 \text{ pF}$ $R_L = 280\Omega$	W
t_{PLH}	Turn Off Delay Preset to Output		8.0	12	ns		X
t_{PHL}	Turn On Delay Preset to Output (Clock LOW)		23	35	ns		X
t_{PHL}	Turn On Delay Preset to Output (Clock HIGH)		15	20	ns		X
t_{PLH}	Turn Off Delay Clock to Output	5.0	10	15	ns		W
t_{PHL}	Turn On Delay Clock to Output	8.0	16	20	ns		W

NOTES:

- (1) For conditions shown as MIN. or MAX., use the appropriate value specified under recommended operating conditions for the applicable device type.
- (2) Typical limits are at $V_{CC} = 5.0 \text{ V}, 25^\circ\text{C}$.
- (3) Not more than one output should be shorted at a time, and duration of short-circuit test should not exceed 1 second.

5

JK EDGE TRIGGERED FLIP-FLOP WITH AND INPUTS

DESCRIPTION — The HSTTL/SSI 9H102/54102, 74H102 is a High Speed JK Negative Edge Triggered flip-flop. They feature gated JK inputs and an asynchronous clear input. The AND gate inputs are inhibited while the clock input is LOW; when the clock goes HIGH, the inputs are enabled and data will be accepted. Logic state of J and K inputs may be allowed to change when the clock pulse is in a HIGH state and bistable will perform according to the truth table as long as minimum set-up times are observed. Input data is transferred to the outputs on the negative edge of the clock pulse.

LOGIC AND CONNECTION DIAGRAM

DIP (TOP VIEW)

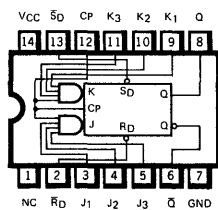

NC — No internal connection.

FLATPAK (TOP VIEW)

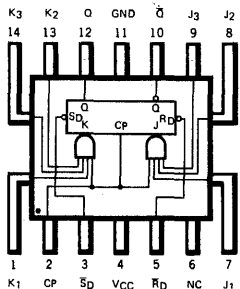

SCHEMATIC DIAGRAM

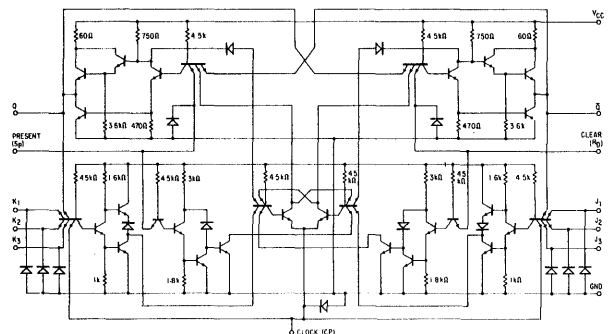

Positive logic:

- LOW input to preset sets Q to HIGH level
- LOW input to clear sets Q to LOW level
- Preset and clear are independent of clock

TRUTH TABLE

t_n		t_{n+1}
J	K	Q
L	L	Q_n
L	H	L
H	L	H
H	H	\bar{Q}_n

NOTES:

- J = J1-J2-J3
- K = K1-K2-K3
- t_n = Bit time before clock pulse
- t_{n+1} = Bit time after clock pulse

CLOCK WAVEFORM

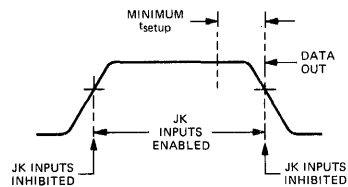

LOGIC DIAGRAM

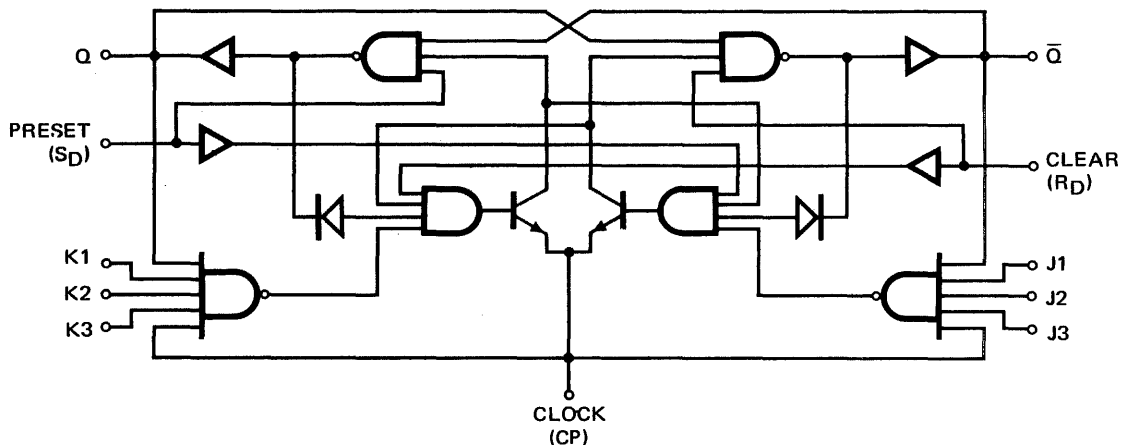

FAIRCHILD HIGH SPEED TTL/SSI • 9H102/54H102, 74H102

RECOMMENDED OPERATING CONDITIONS

PARAMETER	9H102XM/54H102XM			9H102XC/74H102XC			UNITS
	MIN.	TYP.	MAX.	MIN.	TYP.	MAX.	
Supply Voltage V_{CC}	4.5	5.0	5.5	4.75	5.0	5.25	Volts
Operating Free-Air Temperature Range	-55	25	125	0	25	70	°C
Fan Out from Each Output			12.5			12.5	U.L.
Width of Clock Pulse, $t_{p(\text{clock})}$ (See Fig. W)	10			10			ns
Width of Preset Pulse, $t_{p(\text{preset})}$ (See Fig. X)	15			15			ns
Width of Clear Pulse, $t_{p(\text{clear})}$ (See Fig. X)	15			15			ns
Input Setup Time, t_{setup} (See Clock Waveform)	LOW Level	13		13			ns
	HIGH Level	10		10			
Input Hold Time, t_{hold}	0			0			
Clock Pulse Transition Time, t_{Q} (See Fig. W)			150			150	ns

X = package type; F for Flatpak, D for Ceramic Dip, P for Plastic Dip. See Packaging Information Section for packages available on this product.

ELECTRICAL CHARACTERISTICS OVER OPERATING TEMPERATURE RANGE (Unless Otherwise Noted)

SYMBOL	PARAMETER	LIMITS			UNITS	TEST CONDITIONS (Note 1)	TEST FIGURE
		MIN.	TYP. (Note 1)	MAX.			
V_{IH}	Input HIGH Voltage	2.0			Volts	Guaranteed Input HIGH	41 & 42
V_{IL}	Input LOW Voltage			0.8	Volts	Guaranteed Input LOW	41 & 42
V_{OH}	Output HIGH Voltage	2.4	3.2		Volts	$V_{CC} = \text{MIN.}, I_{OH} = -0.5 \text{ mA}$	41
V_{OL}	Output LOW Voltage		0.25	0.4	Volts	$V_{CC} = \text{MIN.}, I_{OL} = 20 \text{ mA}$	42
I_{IH}	Input HIGH Current at J1, J2, J3 K1, K2, or K3			50	μA	$V_{CC} = \text{MAX.}, V_{IN} = 2.4 \text{ V}$	44
				1.0	mA	$V_{CC} = \text{MAX.}, V_{IN} = 5.5 \text{ V}$	
	Input HIGH Current at Clock	0		-1.0	mA	$V_{CC} = \text{MAX.}, V_{IN} = 2.4 \text{ V}$	44
				1.0	mA	$V_{CC} = \text{MAX.}, V_{IN} = 5.5 \text{ V}$	
I_{IL}	Input LOW Current at J1, J2, J3 K1, K2, K3, Preset, or Clear		-1.0	-2.0	mA	$V_{CC} = \text{MAX.}, V_{IN} = 0.4 \text{ V}$	43
			-3.0	-4.8	mA	$V_{CC} = \text{MAX.}, V_{IN} = 0.4 \text{ V}$	
	Input LOW Current at Clock					$V_{CC} = \text{MAX.}, V_{IN} = 0.4 \text{ V}$	43
I_{OS}	Output Short Circuit Current (Note 3)	-40		-100	mA	$V_{CC} = \text{MAX.}, V_{IN} = 0 \text{ V}$	45
I_{CC}	Supply Current		20	38	mA	$V_{CC} = \text{MAX.}$	44

SWITCHING CHARACTERISTICS ($T_A = 25^\circ$)

SYMBOL	PARAMETER	LIMITS			UNITS	TEST CONDITIONS	TEST FIGURE
		MIN.	TYP.	MAX.			
f_{CLOCK}	Maximum Clock Frequency	40	50		MHz	$V_{CC} = 5.0 \text{ V}$ $C_L = 25 \text{ pF}$ $R_L = 280\Omega$	W
t_{PLH}	Turn Off Delay Preset to Output		8.0	12	ns		X
t_{PHL}	Turn On Delay Clear or Preset to Output (Clock LOW)		23	35	ns		X
t_{PHL}	Turn On Delay Clear or Preset to Output (Clock HIGH)		15	20	ns		X
t_{PLH}	Turn Off Delay Clock to Output	5.0	10	15	ns		W
t_{PHL}	Turn On Delay Clock to Output	8.0	16	20	ns		W

NOTES:

- (1) For conditions shown as MIN. or MAX., use the appropriate value specified under recommended operating conditions for the applicable device type.
- (2) Typical limits are at $V_{CC} = 5.0 \text{ V}, 25^\circ\text{C}$.
- (3) Not more than one output should be shorted at a time, and duration of short-circuit test should not exceed 1 second.



DUAL JK EDGE TRIGGERED FLIP-FLOP WITH SEPARATE CLEARS AND CLOCKS

DESCRIPTION – The HSTTL/SSI 9H103/54H103, 74H103 is a High Speed JK Negative Edge Triggered flip-flop. They feature individual J, K, clock, and asynchronous clear inputs to each flip-flop. When the clock goes HIGH, the inputs are enabled and data will be accepted. Logic state of J and K inputs may be allowed to change when the clock pulse is in a HIGH state and bistable will perform according to the truth table as long as minimum set-up times are observed. Input data is transferred to the outputs on the negative edge of the clock pulse.

LOGIC AND CONNECTION DIAGRAM

DIP (TOP VIEW)

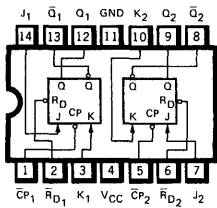

FLATPAK (TOP VIEW)

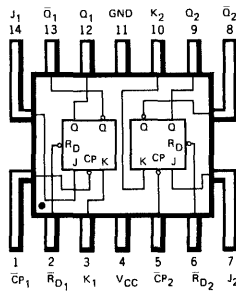

SCHEMATIC DIAGRAM (EACH FLIP-FLOP)

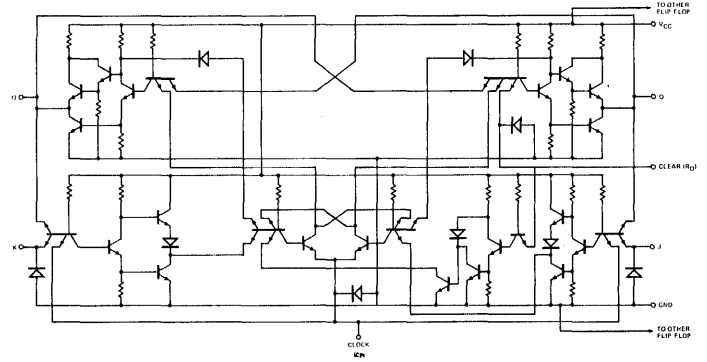

Positive logic: LOW input to clear sets Q to LOW level
Clear is independent of clock

TRUTH TABLE

t_n		t_{n+1}
J	K	Q
L	L	Q_n
L	H	L
H	L	H
H	H	\bar{Q}_n

NOTES:
 t_n = Bit time before clock pulse
 t_{n+1} = Bit time after clock pulse

CLOCK WAVEFORM

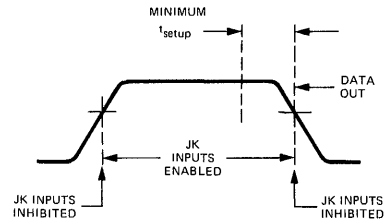

LOGIC DIAGRAM (EACH FLIP-FLOP)

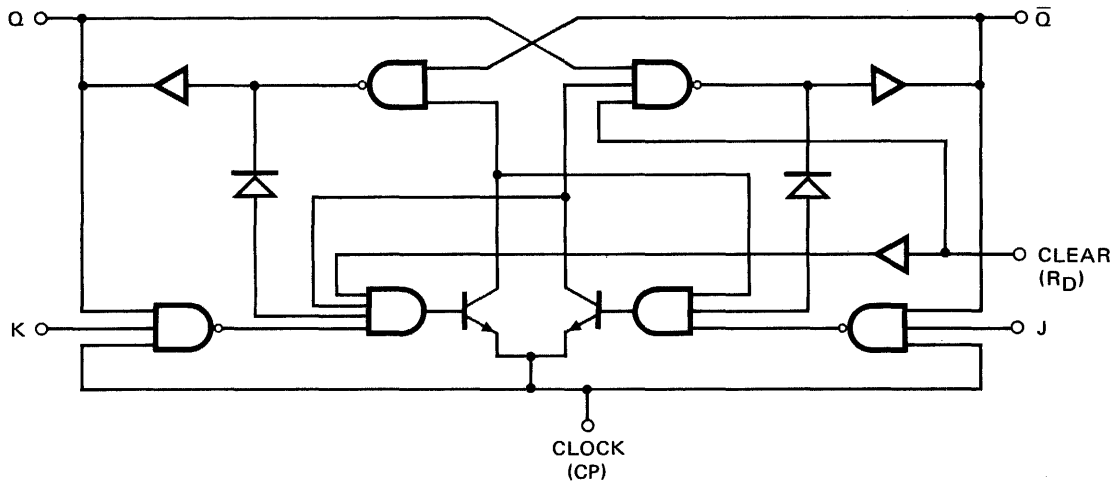

FAIRCHILD HIGH SPEED TTL/SSI • 9H103/54H103, 74H103

RECOMMENDED OPERATING CONDITIONS

PARAMETER	9H103XM/54H103XM			9H103XC/74H103XC			UNITS
	MIN.	TYP.	MAX.	MIN.	TYP.	MAX.	
Supply Voltage V_{CC}	4.5	5.0	5.5	4.75	5.0	5.25	Volts
Operating Free-Air Temperature Range	-55	25	125	0	25	70	°C
Fan Out from Each Output			12.5			12.5	U.L.
Width of Clock Pulse, $t_{p(\text{clock})}$ (See Fig. W)	10			10			ns
Width of Clear Pulse, $t_{p(\text{clear})}$ (See Fig. X)	16			16			ns
Input Setup Time, t_{setup} (See Clock Waveform)	LOW Level	13		13			ns
	HIGH Level	10		10			
Input Hold Time, t_{hold}	0			0			
Clock Pulse Transition Time, t_0 (See Fig. W)			150			150	ns

X = package type; F for Flatpak, D for Ceramic Dip, P for Plastic Dip. See Packaging Information Section for packages available on this product.

ELECTRICAL CHARACTERISTICS OVER OPERATING TEMPERATURE RANGE (Unless Otherwise Noted)

SYMBOL	PARAMETER	LIMITS			UNITS	TEST CONDITIONS (Note 1)	TEST FIGURE
		MIN.	TYP. (Note 2)	MAX.			
V_{IH}	Input HIGH Voltage	2.0			Volts	Guaranteed Input HIGH	46 & 47
V_{IL}	Input LOW Voltage			0.8	Volts	Guaranteed Input LOW	46 & 47
V_{OH}	Output HIGH Voltage	2.4	3.2		Volts	$V_{CC} = \text{MIN.}, I_{OH} = -0.5 \text{ mA}$	46
V_{OL}	Output LOW Voltage		0.25	0.4	Volts	$V_{CC} = \text{MIN.}, I_{OL} = 20 \text{ mA}$	47
I_{IH}	Input HIGH Current at J or K			50	μA	$V_{CC} = \text{MAX.}, V_{IN} = 2.4 \text{ V}$	126
				1.0	mA	$V_{CC} = \text{MAX.}, V_{IN} = 5.5 \text{ V}$	
	Input HIGH Current at Clock	0		-1.0	mA	$V_{CC} = \text{MAX.}, V_{IN} = 2.4 \text{ V}$	126
				1.0	mA	$V_{CC} = \text{MAX.}, V_{IN} = 5.5 \text{ V}$	
Input HIGH Current at Clear			100	μA	$V_{CC} = \text{MAX.}, V_{IN} = 2.4 \text{ V}$	126	
			1.0	mA	$V_{CC} = \text{MAX.}, V_{IN} = 5.5 \text{ V}$		
I_{IL}	Input LOW Current at J, K, or Clear		-1.0	-2.0	mA	$V_{CC} = \text{MAX.}, V_{IN} = 0.4 \text{ V}$	125
	Input LOW Current at Clock		-3.0	-4.8	mA	$V_{CC} = \text{MAX.}, V_{IN} = 0.4 \text{ V}$	125
I_{OS}	Output Short Circuit Current (Note 3)	-40		-100	mA	$V_{CC} = \text{MAX.}, V_{IN} = 0 \text{ V}$	50
I_{CC}	Supply Current		40	76	mA	$V_{CC} = \text{MAX.}$	126

SWITCHING CHARACTERISTICS ($T_A = 25^\circ\text{C}$)

SYMBOL	PARAMETER	LIMITS			UNITS	TEST CONDITIONS	TEST FIGURE
		MIN.	TYP.	MAX.			
f_{CLOCK}	Maximum Clock Frequency	40	50		MHz	$V_{CC} = 5.0 \text{ V}$ $C_L = 25 \text{ pF}$ $R_L = 280\Omega$	W
t_{PLH}	Turn Off Delay Clear to Output		8.0	12	ns		X
t_{PHL}	Turn On Delay Clear to Output (Clock LOW)		23	35	ns		X
t_{PHL}	Turn On Delay Clear to Output (Clock HIGH)		15	20	ns		X
t_{PLH}	Turn Off Delay Clock to Output	5.0	10	15	ns		W
t_{PHL}	Turn On Delay Clock to Output	8.0	16	20	ns		W

NOTES:

- (1) For conditions shown as MIN. or MAX., use the appropriate value specified under recommended operating conditions for the applicable device type.
- (2) Typical limits are at $V_{CC} = 5.0 \text{ V}, 25^\circ\text{C}$.
- (3) Not more than one output should be shorted at a time and duration of short circuit test should not exceed 1 second.

DUAL JK EDGE TRIGGERED FLIP-FLOP WITH SEPARATE PRESETS, CLEARS AND CLOCKS

DESCRIPTION — The HSTTL/SSI 9H106/54H106, 74H106 is a High Speed JK Negative Edge Triggered flip-flop. They feature individual J, K, clock, and asynchronous preset and clear inputs to each flip-flop. When the clock goes HIGH, the inputs are enabled and data will be accepted. Logic state of J and K inputs may be allowed to change when the clock pulse is in a HIGH state and bistable will perform according to the truth table as long as minimum set up times are observed. Input data is transferred to the outputs on the negative edge of the clock pulse.

LOGIC AND CONNECTION DIAGRAM

DIP (TOP VIEW)

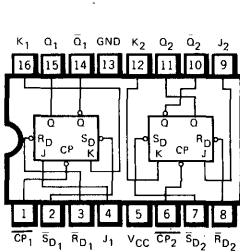

FLATPAK (Top View)

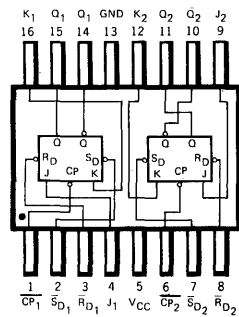

SCHEMATIC DIAGRAM (EACH FLIP-FLOP)

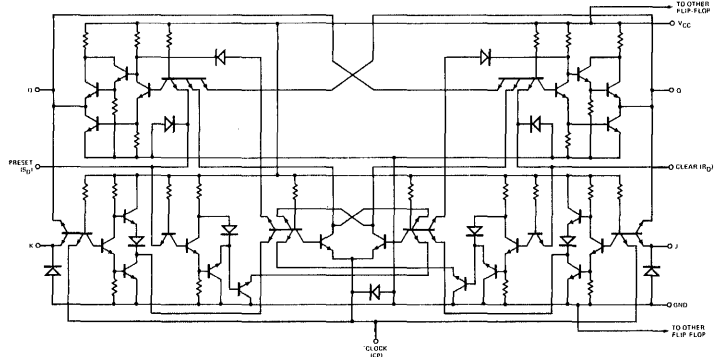

Positive logic: LOW input to preset sets Q to HIGH level
 LOW input to clear sets Q to LOW level
 Preset and clear are independent of clock

TRUTH TABLE

t_n		t_{n+1}
J	K	Q
L	L	Q_n
L	H	L
H	L	H
H	H	\bar{Q}_n

NOTES:
 t_n = Bit time before clock pulse
 t_{n+1} = Bit time after clock pulse

CLOCK WAVEFORM

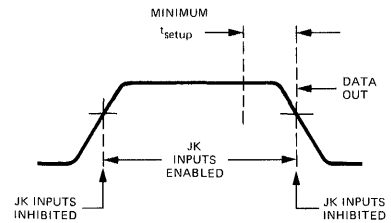

LOGIC DIAGRAM (EACH FLIP-FLOP)

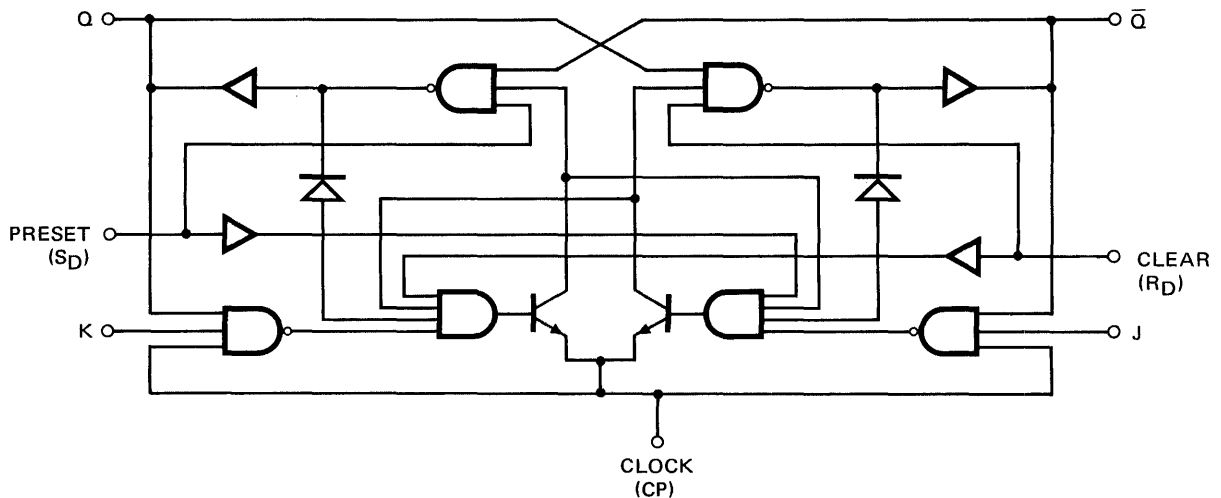

FAIRCHILD HIGH SPEED TTL/SSI • 9H106/54H106, 74H106

RECOMMENDED OPERATING CONDITIONS

PARAMETER	9H106XM/54H106XM			9H106XC/74H106XC			UNITS
	MIN.	TYP.	MAX.	MIN.	TYP.	MAX.	
Supply Voltage V_{CC}	4.5	5.0	5.5	4.75	5.0	5.25	Volts
Operating Free-Air Temperature Range	-55	25	125	0	25	70	°C
Fan Out from Each Output			12.5			12.5	U.L.
Width of Clock Pulse, $t_p(\text{clock})$ (See Fig. W)	10			10			ns
Width of Preset Pulse, $t_p(\text{preset})$ (See Fig. X)	16			16			ns
Width of Clear Pulse, $t_p(\text{clear})$ (See Fig. X)	16			16			ns
Input Setup Time, t_{setup} (See Clock Waveform)	LOW Level	13		13			ns
	HIGH Level	10		10			
Input Hold Time, t_{hold}	0			0			
Clock Pulse Transition Time, t_Q (See Fig. W)			150			150	ns

X = package type; F for Flatpak, D for Ceramic Dip, P for Plastic Dip. See Packaging Information Section for packages available on this product.

ELECTRICAL CHARACTERISTICS OVER OPERATING TEMPERATURE RANGE (Unless Otherwise Noted)

SYMBOL	PARAMETER	LIMITS			UNITS	TEST CONDITIONS (Note 1)	TEST FIGURE
		MIN.	TYP. (Note 2)	MAX.			
V_{IH}	Input HIGH Voltage	2.0			Volts	Guaranteed Input HIGH	46 & 47
V_{IL}	Input LOW Voltage			0.8	Volts	Guaranteed Input LOW	46 & 47
V_{OH}	Output HIGH Voltage	2.4	3.2		Volts	$V_{CC} = \text{MIN.}, I_{OH} = -0.5 \text{ mA}$	46
V_{OL}	Output LOW Voltage		0.25	0.4	Volts	$V_{CC} = \text{MIN.}, I_{OL} = 20 \text{ mA}$	47
I_{IH}	Input HIGH Current at J or K			50	μA	$V_{CC} = \text{MAX.}, V_{IN} = 2.4 \text{ V}$	126
				1.0	mA	$V_{CC} = \text{MAX.}, V_{IN} = 5.5 \text{ V}$	
	Input HIGH Current at Clock	0		-1.0	mA	$V_{CC} = \text{MAX.}, V_{IN} = 2.4 \text{ V}$	126
				1.0	mA	$V_{CC} = \text{MAX.}, V_{IN} = 5.5 \text{ V}$	
Input HIGH Current at Preset or Clear			100	μA	$V_{CC} = \text{MAX.}, V_{IN} = 2.4 \text{ V}$	126	
			1.0	mA	$V_{CC} = \text{MAX.}, V_{IN} = 5.5 \text{ V}$		
I_{IL}	Input LOW Current at J, K, Preset, or Clear		-1.0	-2.0	mA	$V_{CC} = \text{MAX.}, V_{IN} = 0.4 \text{ V}$	125
	Input LOW Current at Clock		-3.0	-4.8	mA	$V_{CC} = \text{MAX.}, V_{IN} = 0.4 \text{ V}$	125
I_{OS}	Output Short Circuit Current (Note 3)	-40		-100	mA	$V_{CC} = \text{MAX.}, V_{IN} = 0 \text{ V}$	51
I_{CC}	Supply Current		40	76	mA	$V_{CC} = \text{MAX.}$	126

SWITCHING CHARACTERISTICS ($T_A = 25^\circ$)

SYMBOL	PARAMETER	LIMITS			UNITS	TEST CONDITIONS	TEST FIGURE
		MIN.	TYP.	MAX.			
f_{CLOCK}	Maximum Clock Frequency	40	50		MHz	$V_{CC} = 5.0 \text{ V}$ $C_L = 25 \text{ pF}$ $R_L = 280\Omega$	W
t_{PLH}	Turn Off Delay Preset or Clear to Output		8.0	12	ns		X
t_{PHL}	Turn On Delay Clear or Preset to Output (Clock LOW)		23	35	ns		X
t_{PHL}	Turn On Delay Clear or Preset to Output (Clock HIGH)		15	20	ns		X
t_{PLH}	Turn Off Delay Clock to Output	5.0	10	15	ns		W
t_{PHL}	Turn On Delay Clock to Output	8.0	16	20	ns		W

NOTES:

- (1) For conditions shown as MIN. or MAX., use the appropriate value specified under recommended operating conditions for the applicable device type.
- (2) Typical limits are at $V_{CC} = 5.0 \text{ V}, 25^\circ\text{C}$.
- (3) Not more than one output should be shorted at a time and duration of short circuit test should not exceed 1 second.



DUAL JK EDGE TRIGGERED FLIP-FLOP WITH SEPARATE PRESETS AND A COMMON CLEAR AND CLOCK

DESCRIPTION — The HSTTL/SSI 9H108/54H108, 74H108 is a High Speed JK Negative Edge Triggered flip-flop. They feature individual J,K, and asynchronous preset inputs to each flip-flop as well as common clock and asynchronous clear inputs. When the clock goes HIGH, the inputs are enabled and data will be accepted. Logic state of J and K inputs may be allowed to change when the clock pulse is in a HIGH state and bi-stable will perform according to the truth table as long as minimum set-up times are observed. Input data is transferred to the outputs on the negative edge of the clock pulse.

LOGIC AND CONNECTION DIAGRAM

DIP (TOP VIEW)

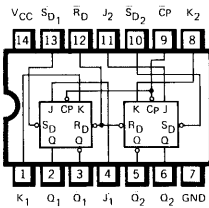

FLATPAK (TOP VIEW)

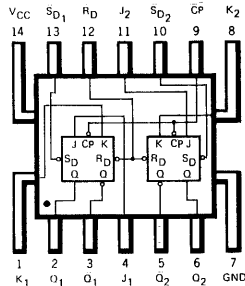

SCHEMATIC DIAGRAM (EACH FLIP-FLOP)

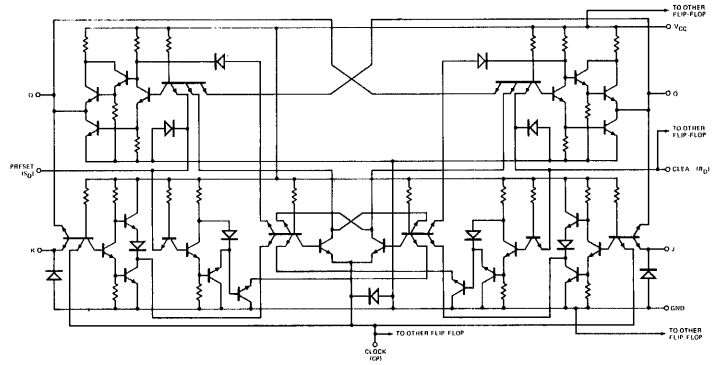

Positive logic: LOW input to preset sets Q to HIGH level
 LOW input to clear sets Q to LOW level
 Preset and clear are independent of clock

TRUTH TABLE

t_n		t_{n+1}
J	K	Q
L	L	Q_n
L	H	L
H	L	H
H	H	\bar{Q}_n

NOTES:
 t_n = Bit time before clock pulse
 t_{n+1} = Bit time after clock pulse

CLOCK WAVEFORM

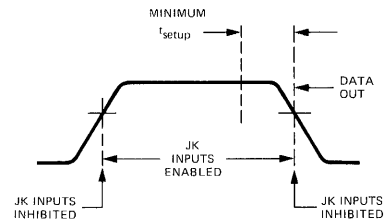

LOGIC DIAGRAM (EACH FLIP-FLOP)

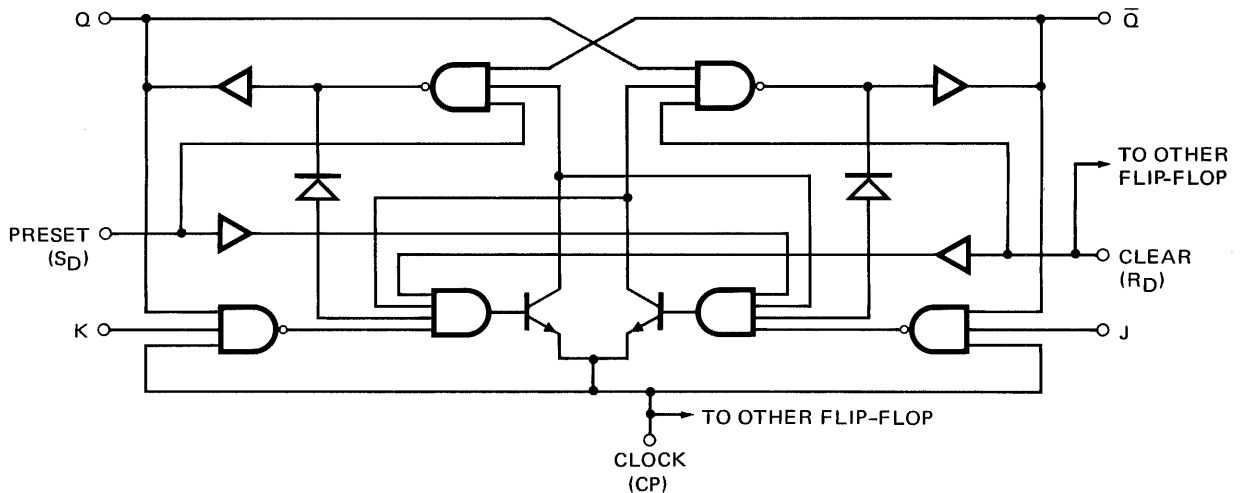

FAIRCHILD HIGH SPEED TTL/SSI • 9H108/54H108, 74H108

RECOMMENDED OPERATING CONDITIONS

PARAMETER	9H108XM/54H108XM			9H108XC/74H108XC			UNITS
	MIN.	TYP.	MAX.	MIN.	TYP.	MAX.	
Supply Voltage V_{CC}	4.5	5.0	5.5	4.75	5.0	5.25	Volts
Operating Free-Air Temperature Range	-55	25	125	0	25	70	°C
Fan Out from Each Output			12.5			12.5	U.L.
Width of Clock Pulse, $t_{p(\text{clock})}$ (See Fig. W)	10			10			ns
Width of Preset Pulse, $t_{p(\text{preset})}$ (See Fig. X)	15			15			ns
Width of Clear Pulse, $t_{p(\text{clear})}$ (See Fig. X)	16			16			ns
Input Setup Time, t_{setup} (See Clock Waveform)	LOW Level	13		13			ns
	HIGH Level	10		10			
Input Hold Time, t_{hold}	0			0			
Clock Pulse Transition Time, t_0 (See Fig. W)			150			150	ns

X = package type; F for Flatpak, D for Ceramic Dip, P for Plastic Dip. See Packaging Information Section for packages available on this product.

ELECTRICAL CHARACTERISTICS OVER OPERATING TEMPERATURE RANGE (Unless Otherwise Noted)

SYMBOL	PARAMETER	LIMITS			UNITS	TEST CONDITIONS (Note 1)	TEST FIGURE
		MIN.	TYP. (Note 2)	MAX.			
V_{IH}	Input HIGH Voltage	2.0			Volts	Guaranteed Input HIGH	46 & 47
V_{IL}	Input LOW Voltage			0.8	Volts	Guaranteed Input LOW	46 & 47
V_{OH}	Output HIGH Voltage	2.4	3.2		Volts	$V_{CC} = \text{MIN.}, I_{OH} = -0.5 \text{ mA}$	46
V_{OL}	Output LOW Voltage		0.25	0.4	Volts	$V_{CC} = \text{MIN.}, I_{OL} = 20 \text{ mA}$	47
I_{IH}	Input HIGH Current at J or K			50	μA	$V_{CC} = \text{MAX.}, V_{IN} = 2.4 \text{ V}$	126
				1.0	mA	$V_{CC} = \text{MAX.}, V_{IN} = 5.5 \text{ V}$	
	Input HIGH Current at Clock	0		-1.0	mA	$V_{CC} = \text{MAX.}, V_{IN} = 2.4 \text{ V}$	126
				1.0	mA	$V_{CC} = \text{MAX.}, V_{IN} = 5.5 \text{ V}$	
	Input HIGH Current at Preset			100	μA	$V_{CC} = \text{MAX.}, V_{IN} = 2.4 \text{ V}$	126
Input HIGH Current at Clear			1.0	mA	$V_{CC} = \text{MAX.}, V_{IN} = 5.5 \text{ V}$		
I_{IL}	Input LOW Current at J, K, or Preset		-1.0	-2.0	mA	$V_{CC} = \text{MAX.}, V_{IN} = 0.4 \text{ V}$	125
	Input LOW Current at Clock		-6.0	-9.6	mA	$V_{CC} = \text{MAX.}, V_{IN} = 0.4 \text{ V}$	125
	Input LOW Current at Clear		-2.0	-4.0	mA	$V_{CC} = \text{MAX.}, V_{IN} = 0.4 \text{ V}$	125
I_{OS}	Output Short Circuit Current (Note 3)	-40		-100	mA	$V_{CC} = \text{MAX.}, V_{IN} = 0 \text{ V}$	51
I_{CC}	Supply Current		40	76	mA	$V_{CC} = \text{MAX.}$	126

SWITCHING CHARACTERISTICS ($T_A = 25^\circ\text{C}$)

SYMBOL	PARAMETER	LIMITS			UNITS	TEST CONDITIONS	TEST FIGURE
		MIN.	TYP.	MAX.			
f_{CLOCK}	Maximum Clock Frequency	40	50		MHz	$V_{CC} = 5.0 \text{ V}$ $C_L = 25 \text{ pF}$ $R_L = 280\Omega$	W
t_{PLH}	Turn Off Delay Preset or Clear to Output		8.0	12	ns		X
t_{PHL}	Turn On Delay Clear or Preset to Output (Clock LOW)		23	35	ns		X
t_{PHL}	Turn On Delay Clear or Preset to Output (Clock HIGH)		15	20	ns		X
t_{PLH}	Turn Off Delay Clock to Output	5.0	10	15	ns		W
t_{PHL}	Turn On Delay Clock to Output	8.0	16	20	ns		W

NOTES:

- (1) For conditions shown as MIN. or MAX., use the appropriate value specified under recommended operating conditions for the applicable device type.
- (2) Typical limits are at $V_{CC} = 5.0 \text{ V}, 25^\circ\text{C}$.
- (3) Not more than one output should be shorted at a time and duration of short circuit test should not exceed 1 second.



DUAL J \bar{K} FLIP-FLOP

DESCRIPTION — The 9S109 consists of two high speed, completely independent transition clocked J \bar{K} flip-flops. The clocking operation is independent of rise and fall times of the clock waveform. The JK design allows operation as a D flip-flop by simply connecting the J and K pins together. The 9S109 is a pin for pin replacement of the 9024.

**LOGIC AND CONNECTION DIAGRAM
DIP (TOP VIEW)**

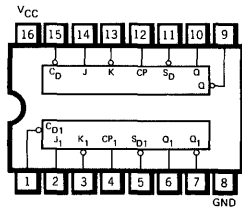

LOGIC DIAGRAM

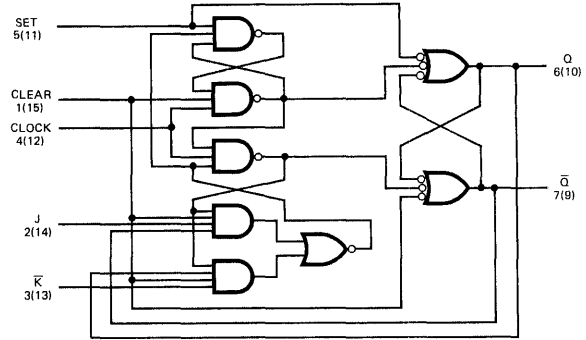

TRUTH TABLES

**SYNCHRONOUS ENTRY
D MODE OPERATION**

INPUTS AT t_n		OUTPUTS AT t_{n+1}	
D		Q	\bar{Q}
L		L	H
H		H	L

**SYNCHRONOUS ENTRY
J-K MODE OPERATION**

INPUTS AT t_n		OUTPUTS AT t_{n+1}	
J	\bar{K}	Q	\bar{Q}
L	H	No Change	
L	L	L	H
H	H	H	L
H	L	Toggles	

**ASYNCHRONOUS ENTRY INDEPENDENT
OF CLOCK & SYNCHRONOUS INPUTS**

INPUTS		OUTPUTS	
\bar{S}_D	\bar{C}_D	Q	\bar{Q}
L	L	H	H
L	H	H	L
H	L	L	H
H	H	No Change	

L = LOW Logic Level
H = HIGH Logic Level

RECOMMENDED OPERATING CONDITIONS

PARAMETER	9S109XM			9S109XC			UNITS
	MIN.	TYP.	MAX.	MIN.	TYP.	MAX.	
Supply Voltage V_{CC}	4.5	5.0	5.5	4.75	5.0	5.25	Volts
Operating Free-Air Temperature Range	-55	25	125	0	25	/5	$^{\circ}$ C

X = package type; F for Flatpak, D for Ceramic Dip, P for Plastic Dip. See Packaging Information Section for packages available on this product.

ELECTRICAL CHARACTERISTICS OVER OPERATING TEMPERATURE RANGE (Unless Otherwise Noted)

SYMBOL	PARAMETER	LIMITS			UNITS	TEST CONDITIONS (Note 1)
		MIN.	TYP. (Note 2)	MAX.		
V_{IH}	Input HIGH Voltage	2.0			Volts	Guaranteed Input HIGH Voltage
V_{IL}	Input LOW Voltage			0.8	Volts	Guaranteed Input LOW Voltage
V_{CD}	Input Clamp Diode Voltage		-0.65	-1.2	Volts	$V_{CC} = \text{MIN.}, I_I = -18 \text{ mA}$
V_{OH}	Output HIGH Voltage	XM	2.5	3.4	Volts	$V_{CC} = \text{MIN.}, I_{OH} = -1.0 \text{ mA}$
		XC	2.7	3.4		
V_{OL}	Output LOW Voltage		0.35	0.5	Volts	$V_{CC} = \text{MIN.}, I_{OL} = 20 \text{ mA}$
I_{IH}	Input HIGH Current at	J \bar{K}		1.0	μ A	$V_{CC} = \text{MAX.}, V_{IN} = 2.7 \text{ V}$
		\bar{S}_D		2.0		
		\bar{C}_D		4.0		
I_{IL}	Input LOW Current at	J \bar{K}		-1.4	mA	$V_{CC} = \text{MAX.}, V_{IN} = 0.5 \text{ V}$
		\bar{S}_D		-2.8		
		\bar{C}_D		-5.6		
I_{OS}	Output Short Circuit Current (Note 3)	-40	-65	-100	mA	$V_{CC} = \text{MAX.}, V_{OUT} = 0 \text{ V}$
I_{CC}	Supply Current		32	52	mA	$V_{CC} = \text{MAX.}, (\text{Note 4})$

Notes on following page

FAIRCHILD SUPER HIGH SPEED TTL/SSI • 9S109

SWITCHING CHARACTERISTICS ($T_A = 25^\circ\text{C}$)

SYMBOL	PARAMETER	LIMITS			UNITS	TEST CONDITIONS
		MIN.	TYP.	MAX.		
f_{max}	Maximum Clock Frequency		100		MHz	$V_{\text{CC}} = 5.0\text{ V}$ $C_L = 15\text{ pF}$
t_{PLH}	Turn Off Delay Clear or Preset to Output		4.0		ns	
t_{PHL}	Turn On Delay Clear or Preset to Output		7.0		ns	
t_{PLH}	Turn Off Delay Clock to Output		7.0		ns	
t_{PHL}	Turn On Delay Clock to Output		7.0		ns	

NOTES:

- (1) For conditions shown as MIN. or MAX., use the appropriate value specified under recommended operating conditions for the applicable device type.
- (2) Typical limits are at $V_{\text{CC}} = 5.0\text{ V}$, 25°C .
- (3) Not more than one output should be shorted at a time.
- (4) I_{CC} is measured Clock, Set and \bar{K} inputs grounded.

SWITCHING CHARACTERISTICS

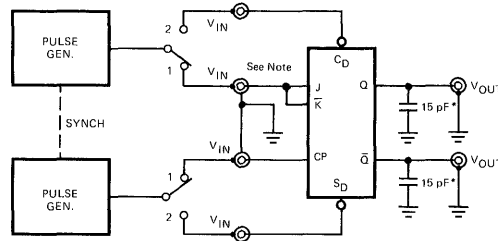

*Includes all probe and jig capacitance.

NOTE: For testing 9S109, connect J, \bar{K} pins together to form a D input.

PULSE GENERATOR SETTINGS

CLOCK	$\bar{J}\bar{K}$	DIRECT SET, CLEAR
$f \approx 1\text{ MHz}$	$f \approx 500\text{ kHz}$	$f \approx 1\text{ MHz}$
$t_f = t_r = 2.5\text{ ns}$	$t_f = t_r = 2.5\text{ ns}$	$t_f = t_r = 2.5\text{ ns}$
Amp = 0 to 3 V	Amp = 0 to 3 V	Amp = 0 to 3 V
Duty cycle = 50%	$t_{\text{setup}}(\text{HIGH})$ $t_{\text{setup}}(\text{LOW})$ Duty cycle = Adjust pulse width to attain $t_{\text{setup}}(\text{HIGH})$ and $t_{\text{setup}}(\text{LOW})$ relative to clock as shown in waveforms.	Duty cycle = Adjust pulse width and synch to attain waveforms shown.

SWITCHING WAVEFORMS

CLOCK TO OUTPUT DELAY†

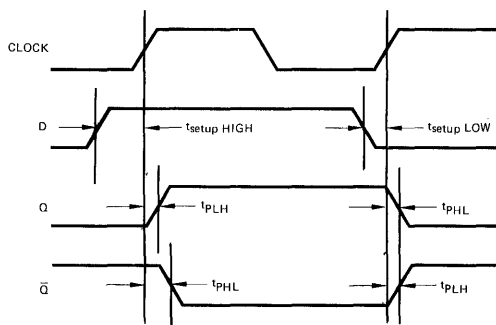

SWITCH IN POSITION 1

DIRECT SET, AND CLEAR TO OUTPUT DELAY

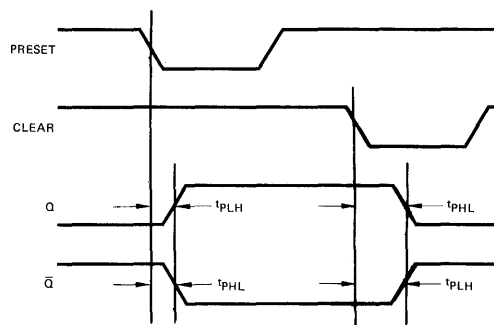

SWITCH IN POSITION 2

†Direct set and clear inputs connected to V_{CC} thru $2\text{ k}\Omega$ resistor during test.

DUAL JK EDGE-TRIGGERED FLIP-FLOP

DESCRIPTION — The 9S112/54S112, 74S112 dual JK flip-flops feature individual J, K, clock, and asynchronous preset and clear inputs to each flip-flop. When the clock goes HIGH, the inputs are enabled and data will be accepted. The logic level of the J and K inputs may be allowed to change when the clock pulse is HIGH and the bistable will perform according to the truth table as long as minimum setup and hold time are observed. Input data is transferred to the outputs on the negative-going edge of the clock pulse.

**LOGIC AND CONNECTION DIAGRAM
DIP (TOP VIEW)**

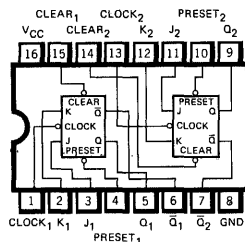

Positive logic: LOW input to preset sets Q to HIGH level.
 LOW input to clear resets Q to LOW level.
 Clear and preset are independent of clock.

TRUTH TABLES

t_n		t_{n+1}
J	K	Q
L	L	Q_n
L	H	L
H	L	H
H	H	\bar{Q}_n

Preset	Clear	Q	\bar{Q}
L	L	H	H
L	H	H	L
H	L	L	H
H	H	No Change	

NOTES:

- A. t_n = Bit time before clock pulse.
- B. t_{n+1} = Bit time after clock pulse.

**LOGIC DIAGRAM
(Each Flip-Flop)**

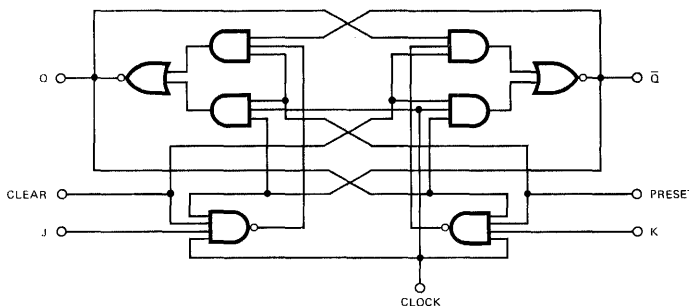

RECOMMENDED OPERATING CONDITIONS

PARAMETER	9S112XM/54S112XM			9S112XC/74S112XC			UNITS
	MIN.	TYP.	MAX.	MIN.	TYP.	MAX.	
Supply Voltage V_{CC}	4.5	5.0	5.5	4.75	5.0	5.25	Volts
Operating Free-Air Temperature Range	-55	25	125	0	25	75	°C

X = package type; F for Flatpak, D for Ceramic Dip, P for Plastic Dip. See Packaging Information Section for packages available on this product.

FAIRCHILD SUPER HIGH SPEED TTL/SSI • 9S112/54S112, 74S112

ELECTRICAL CHARACTERISTICS OVER OPERATING TEMPERATURE RANGE (Unless Otherwise Noted)

SYMBOL	PARAMETER		LIMITS			UNITS	TEST CONDITIONS (Note 1)
			MIN.	TYP. (Note 2)	MAX.		
V _{IH}	Input HIGH Voltage		2.0			Volts	Guaranteed Input HIGH Voltage
V _{IL}	Input LOW Voltage				0.8	Volts	Guaranteed Input LOW Voltage
V _{CD}	Input Clamp Diode Voltage			-0.65	-1.2	Volts	V _{CC} = MIN., I _I = -18 mA
V _{OH}	Output HIGH Voltage	XM	2.5	3.4		Volts	V _{CC} = MIN., I _{OH} = -1.0 mA
		XC	2.7	3.4			
V _{OL}	Output LOW Voltage			0.35	0.5	Volts	V _{CC} = MIN., I _{OL} = 20 mA
I _{IH}	Input HIGH Current at	J,K		1.0	50	μA	V _{CC} = MAX., V _{IN} = 2.7 V
		Clock		2.0	100		
		Preset Clear					
I _{IL}	Input LOW Current at	J,K		-0.96	-1.6	mA	V _{CC} = MAX., V _{IN} = 0.5 V
		Clock		-2.8	-4.0		
		Preset Clear		-4.9	-7.0		
I _{OS}	Output Short Circuit Current (Note 3)		-40	-65	-100	mA	V _{CC} = MAX., V _{OUT} = 0V
I _{CC}	Supply Current			30	50	mA	V _{CC} = MAX. (Note 4)

SWITCHING CHARACTERISTICS (T_A = 25°C)

SYMBOL	PARAMETER	LIMITS			UNITS	TEST CONDITIONS
		MIN.	TYP.	MAX.		
f _{max}	Maximum Clock Frequency	80	125		MHz	V _{CC} = 5.0 V C _L = 15 pF
t _{PLH}	Turn Off Delay Clear or Preset to Output			7.0	ns	
t _{PHL}	Turn On Delay Clear or Preset to Output			7.0	ns	
t _{PLH}	Turn Off Delay Clock to Output			7.0	ns	
t _{PHL}	Turn On Delay Clock to Output			7.0	ns	

NOTES:

- (1) For conditions shown as MIN. or MAX., use the appropriate value specified under recommended operating conditions for the applicable device type.
- (2) Typical limits are at V_{CC} = 5.0 V, 25°C.
- (3) Not more than one output should be shorted at a time.
- (4) I_{CC} is measured with outputs open, clock grounded and J,K, preset and clear at 4.5 V.

5

DUAL JK EDGE-TRIGGERED FLIP-FLOP

DESCRIPTION — The 9S113/54S113, 74S113 offer individual J, K, preset, and clock inputs. These monolithic dual flip-flops are designed so that when the clock goes HIGH, the inputs are enabled and data will be accepted. The logic level of the J and K inputs may be allowed to change when the clock pulse is HIGH and the bistable will perform according to the truth table as long as minimum setup times are observed. Input data is transferred to the outputs on the negative-going edge of the clock pulse.

LOGIC AND CONNECTION DIAGRAM
DIP (TOP VIEW)

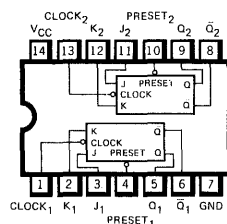

Positive logic: LOW input to preset sets Q to HIGH level
Preset is independent of clock

TRUTH TABLES

t_n		t_{n+1}
J	K	Q
L	L	Q_n
L	H	L
H	L	H
H	H	\bar{Q}_n

Preset	Q	\bar{Q}
L	H	L
H	No Change	

NOTES:
A. t_n = Bit time before clock pulse.
B. t_{n+1} = Bit time after clock pulse.

LOGIC DIAGRAM
(Each Flip-Flop)

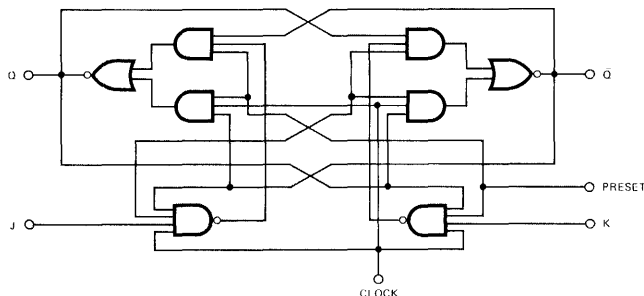

RECOMMENDED OPERATING CONDITIONS

PARAMETER	9S113XM/54S113XM			9S113XC/74S113XC			UNITS
	MIN.	TYP.	MAX.	MIN.	TYP.	MAX.	
Supply Voltage V_{CC}	4.5	5.0	5.5	4.75	5.0	5.25	Volts
Operating Free-Air Temperature Range	-55	25	125	0	25	75	°C

X = package type; F for Flatpak, D for Ceramic Dip, P for Plastic Dip. See Packaging Information Section for packages available on this product.

FAIRCHILD SUPER HIGH SPEED TTL/SSI • 9S113/54S113, 74S113

ELECTRICAL CHARACTERISTICS OVER OPERATING TEMPERATURE RANGE (Unless Otherwise Noted)

SYMBOL	PARAMETER	LIMITS			UNITS	TEST CONDITIONS (Note 1)
		MIN.	TYP. (Note 2)	MAX.		
V _{IH}	Input HIGH Voltage	2.0			Volts	Guaranteed Input HIGH Voltage
V _{IL}	Input LOW Voltage			0.8	Volts	Guaranteed Input LOW Voltage
V _{CD}	Input Clamp Diode Voltage		-0.65	-1.2	Volts	V _{CC} = MIN., I _I = -18 mA
V _{OH}	Output HIGH Voltage	XM	2.5	3.4	Volts	V _{CC} = MIN., I _{OH} = -1.0 mA
		XC	2.7	3.4		
V _{OL}	Output LOW Voltage		0.35	0.5	Volts	V _{CC} = MIN., I _{OL} = 20 mA
I _{IH}	Input HIGH Current at	J,K		1.0	μA	V _{CC} = MAX., V _{IN} = 2.7 V
		Clock		2.0		
		Preset		2.0		
I _{IL}	Input LOW Current at	J,K		-0.96	mA	V _{CC} = MAX., V _{IN} = 0.5 V
		Clock		-2.8		
		Preset		-4.9		
I _{OS}	Output Short Circuit Current (Note 3)	-40	-65	-100	mA	V _{CC} = MAX., V _{OUT} = 0V
I _{CC}	Supply Current		30	50	mA	V _{CC} = MAX. (Note 4)

SWITCHING CHARACTERISTICS (T_A = 25°C)

SYMBOL	PARAMETER	LIMITS			UNITS	TEST CONDITIONS
		MIN.	TYP.	MAX.		
f _{max}	Maximum Clock Frequency	80	125		MHz	V _{CC} = 5.0 V C _L = 15 pF
t _{PLH}	Turn Off Delay Clear or Preset to Output			7.0	ns	
t _{PHL}	Turn On Delay Clear or Preset to Output			7.0	ns	
t _{PLH}	Turn Off Delay Clock to Output			7.0	ns	
t _{PHL}	Turn On Delay Clock to Output			7.0	ns	

NOTES:

- (1) For conditions shown as MIN. or MAX., use the appropriate value specified under recommended operating conditions for the applicable device type.
- (2) Typical limits are at V_{CC} = 5.0 V, 25°C.
- (3) Not more than one output should be shorted at a time.
- (4) I_{CC} is measured with outputs open, clock grounded and J,K, preset and clear at 4.5 V.

5

DUAL JK EDGE-TRIGGERED FLIP-FLOP

DESCRIPTION — The 9S114/54S114, 74S114 offer common clock and common clear inputs and individual J, K, and preset inputs. These monolithic dual flip-flops are designed so that when the clock goes HIGH, the inputs are enabled and data will be accepted. The logic level of the J and K inputs may be allowed to change when the clock pulse is HIGH and the bistable will perform according to the truth table as long as minimum setup times are observed. Input data is transferred to the outputs on the negative-going edge of the clock pulse.

LOGIC AND CONNECTION DIAGRAM
DIP (TOP VIEW)

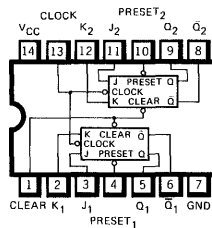

Positive logic: LOW input to preset sets Q to HIGH level.
LOW input to clear resets Q to LOW level.
Preset and clear are independent of clock.

TRUTH TABLES

t_n		t_{n+1}
J	K	Q
L	L	Q_n
L	H	L
H	L	H
H	H	\bar{Q}_n

Preset	Clear	Q	\bar{Q}
L	L	H	H
L	H	H	L
H	L	L	H
H	H	No Charge	No Charge

NOTES:

- A. t_n = Bit time before clock pulse.
- B. t_{n+1} = Bit time after clock pulse.

LOGIC DIAGRAM
(Each Flip-Flop)

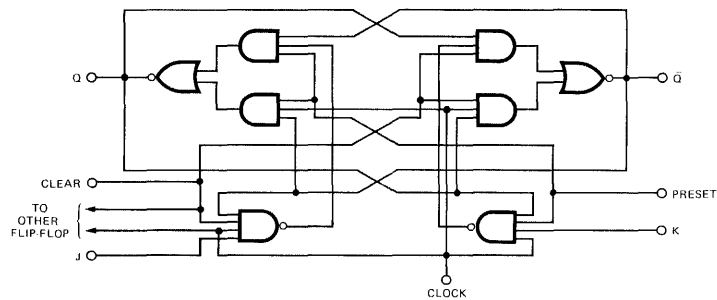

RECOMMENDED OPERATING CONDITIONS

PARAMETER	9S114XM/54S114XM			9S114XC/74S114XC			UNITS
	MIN.	TYP.	MAX.	MIN.	TYP.	MAX.	
Supply Voltage V_{CC}	4.5	5.0	5.5	4.75	5.0	5.25	Volts
Operating Free-Air Temperature Range	-55	25	125	0	25	75	°C

X = package type; F for Flatpak, D for Ceramic Dip, P for Plastic Dip. See Packaging Information Section for packages available on this product.

FAIRCHILD SUPER HIGH SPEED TTL/SSI • 9S114/54S114, 74S114

ELECTRICAL CHARACTERISTICS OVER OPERATING TEMPERATURE RANGE (Unless Otherwise Noted)

SYMBOL	PARAMETER	LIMITS			UNITS	TEST CONDITIONS (Note 2)
		MIN.	TYP. (Note 2)	MAX.		
V _{IH}	Input HIGH Voltage	2.0			Volts	Guaranteed Input HIGH Voltage
V _{IL}	Input LOW Voltage			0.8	Volts	Guaranteed Input LOW Voltage
V _{CD}	Input Clamp Diode Voltage		-0.65	-1.2	Volts	V _{CC} = MIN., I _I = -18 mA
V _{OH}	Output HIGH Voltage	XM	2.5	3.4	Volts	V _{CC} = MIN., I _{OH} = -1.0 mA
		XC	2.7	3.4		
V _{OL}	Output LOW Voltage		0.35	0.5	Volts	V _{CC} = MIN., I _{OL} = 20 mA
I _{IH}	Input HIGH Current at	JK		1.0	μA	V _{CC} = MAX., V _{IN} = 2.7 V
		Clock		4.0		
		Preset		2.0		
		Clear		4.0		
I _{IL}	Input LOW Current at	JK		-0.96	mA	V _{CC} = MAX., V _{IN} = 0.5 V
		Clock		-5.6		
		Preset		-4.9		
		Clear		-9.8		
I _{OS}	Output Short Circuit Current (Note 3)	-40	-65	-100	mA	V _{CC} = MAX., V _{OUT} = 0V
I _{CC}	Supply Current		30	50	mA	V _{CC} = MAX. (Note 4)

SWITCHING CHARACTERISTICS (T_A = 25° C)

SYMBOL	PARAMETER	LIMITS			UNITS	TEST CONDITIONS
		MIN.	TYP.	MAX.		
f _{max}	Maximum Clock Frequency	80	125		MHz	V _{CC} = 5.0 V C _L = 15 pF
t _{PLH}	Turn Off Delay Clear or Preset to Output			7.0	ns	
t _{PHL}	Turn On Delay Clear or Preset to Output			7.0	ns	
t _{PLH}	Turn Off Delay Clock to Output			7.0	ns	
t _{PHL}	Turn On Delay Clock to Output			7.0	ns	

Notes:

- (1) For conditions shown as MIN. or MAX., use the appropriate value specified under recommended operating conditions for the applicable device type.
- (2) Typical limits are at V_{CC} = 5.0 V, 25° C.
- (3) Not more than one output should be shorted at a time.
- (4) I_{CC} is measured with outputs open, clock grounded and J, K, preset and clear at 4.5 V.

FAIRCHILD SUPER HIGH SPEED TTL/SSI • 9S140/54S140, 74S140

DUAL 4-INPUT NAND LINE DRIVER

LOGIC AND CONNECTION DIAGRAM
DIP (TOP VIEW)

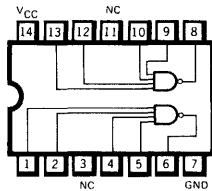

Positive logic: $Y = \overline{ABCD}$

NC—No internal connection.

SCHEMATIC DIAGRAM
(EACH GATE)

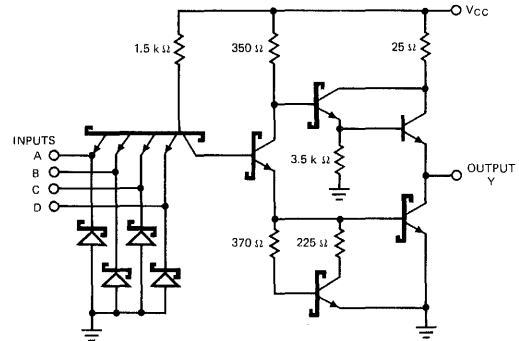

Component values shown are typical.

RECOMMENDED OPERATING CONDITIONS

PARAMETER	9S140XM/54S140XM			9S140XC/74S140XC			UNITS
	MIN.	TYP.	MAX.	MIN.	TYP.	MAX.	
Supply Voltage V_{CC}	4.5	5.0	5.5	4.75	5.0	5.25	Volts
Operating Free-Air Temperature Range	-55	25	125	0	25	75	°C
Fan Out From Each Output			37.5*			37.5*	U.L.

*37.5 (U.L.) is the LOW drive factor and 75 (U.L.) is the HIGH drive factor.

X = package type; F for Flatpak, D for Ceramic Dip, P for Plastic Dip. See Packaging Information Section for packages available on this product.

ELECTRICAL CHARACTERISTICS OVER OPERATING TEMPERATURE RANGE (Unless Otherwise Noted)

SYMBOL	PARAMETER	LIMITS			UNITS	TEST CONDITIONS (Note 1)
		MIN.	TYP. (Note 2)	MAX.		
V_{IH}	Input HIGH Voltage	2.0			Volts	Guaranteed Input HIGH Voltage
V_{IL}	Input LOW Voltage			0.8	Volts	Guaranteed Input LOW Voltage
V_{CD}	Input Clamp Diode Voltage		-0.65	-1.2	Volts	$V_{CC} = \text{MIN.}, I_{IN} = -18\text{mA}$
V_{OH}	Output HIGH Voltage	XM	2.0	2.8	Volts	$V_{CC} = \text{MIN.}, V_{IN} = 0.5\text{V}, R_0 = 50\Omega \text{ to Gnd}$
		XC	2.0	2.8		
V_{OL}	Output LOW Voltage		0.4	0.5	Volts	$V_{CC} = \text{MIN.}, I_{OL} = 60\text{mA}, V_{IN} = 2.0\text{V}$
I_{IH}	Input HIGH Current		1.0	100	μA	Each Input
				1.0	mA	
I_{IL}	Input LOW Current		-2.5	-4.0	mA	Each Input
I_{OS}	Output Short Circuit Current (Note 3)	-50	-150	-225	mA	$V_{CC} = \text{MAX.}, V_{OUT} = 0\text{V}$
I_{CCH}	Supply Current HIGH		8.2	18.0	mA	$V_{CC} = \text{MAX.}, V_{IN} = 0\text{V}$
I_{CCL}	Supply Current LOW		27.2	44.0	mA	$V_{CC} = \text{MAX.}, \text{Inputs Open}$

SWITCHING CHARACTERISTICS ($T_A = 25^\circ\text{C}$)

SYMBOL	PARAMETER	LIMITS			UNITS	TEST CONDITIONS	TEST FIGURES
		MIN.	TYP.	MAX.			
t_{PLH}	Turn Off Delay Input to Output	2.0	4.0	6.5	ns	$V_{CC} = 5.0\text{V}$ $C_L = 50\text{pF}$	DD
t_{PHL}	Turn On Delay Input to Output	2.0	4.0	6.5	ns		

NOTES:

(1) For conditions shown as MIN. or MAX., use the appropriate value specified under recommended operating conditions for the applicable device type.

(2) Typical limits are at $V_{CC} = 5.0\text{V}, 25^\circ\text{C}$.

(3) Not more than one output should be shorted at a time.

FAIRCHILD SERIES TTL/SSI

9N/54,74

TYPICAL CHARACTERISTICS*

PROPAGATION DELAY TIME TO LOW LEVEL VERSUS AMBIENT TEMPERATURE

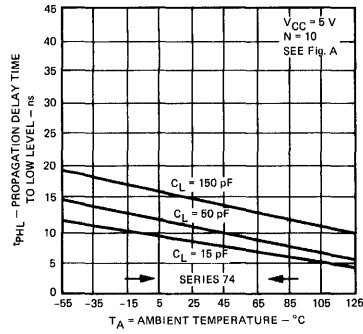

PROPAGATION DELAY TIME TO HIGH LEVEL VERSUS AMBIENT TEMPERATURE

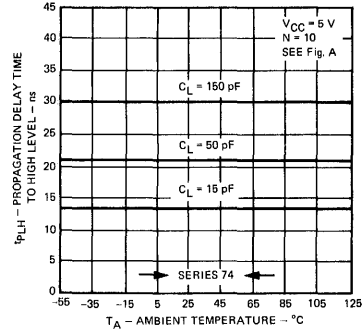

PROPAGATION DELAY TIME VERSUS AMBIENT TEMPERATURE

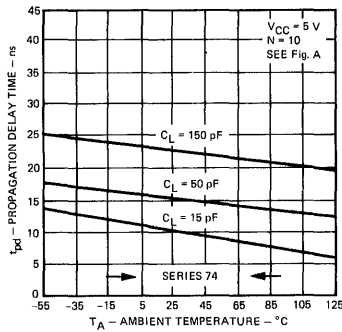

OUTPUT VOLTAGE VERSUS INPUT VOLTAGE

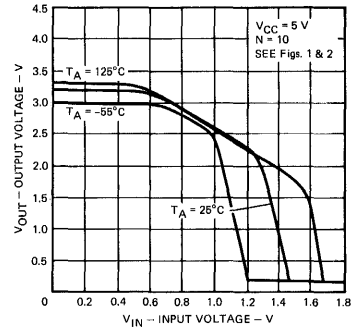

LOW LEVEL OUTPUT VOLTAGE VERSUS SINK CURRENT

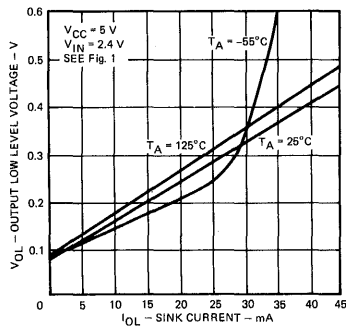

HIGH LEVEL OUTPUT VOLTAGE VERSUS LOAD CURRENT

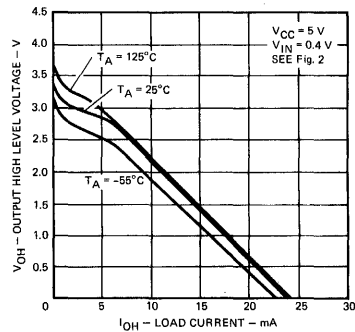

*Unless otherwise noted, data as shown is applicable for: 9N00/5400, 7400; 9N02/5402, 7402; 9N04/5404, 7404; 9N10/5410, 7410; 9N20/5420, 7420; 9N30/5430, 7430; 9N50/5450, 7450; 9N51/5451, 7451; 9N53/5453, 7453; 9N54/5454, 7454.

FAIRCHILD SERIES TTL/SSI

9S/54S,74S

TYPICAL INPUT AND OUTPUT CHARACTERISTICS

OUTPUT CURRENT VERSUS OUTPUT VOLTAGE (OUTPUT LOW)

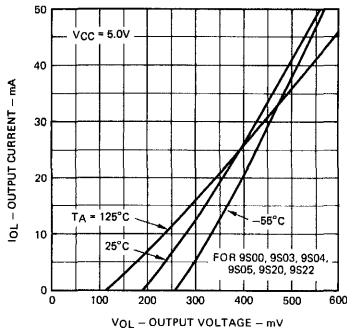

OUTPUT CURRENT VERSUS OUTPUT VOLTAGE (OUTPUT HIGH)

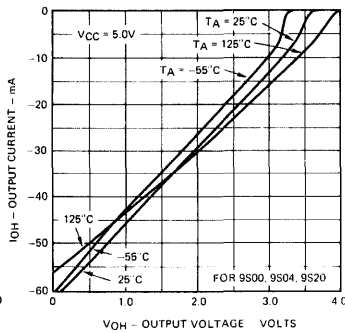

INPUT CURRENT VERSUS INPUT VOLTAGE

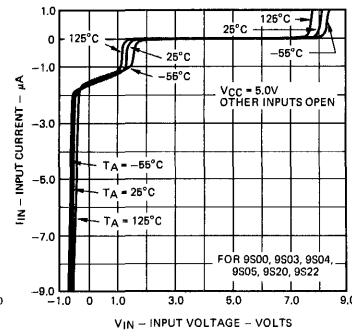

OUTPUT VOLTAGE VERSUS INPUT VOLTAGE

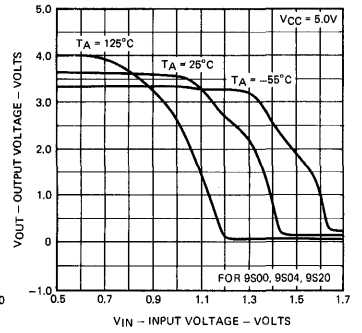

OUTPUT CURRENT VERSUS OUTPUT VOLTAGE (OUTPUT LOW)

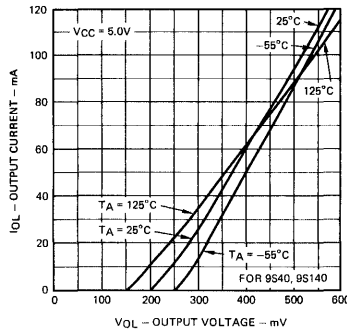

OUTPUT CURRENT VERSUS OUTPUT VOLTAGE (OUTPUT HIGH)

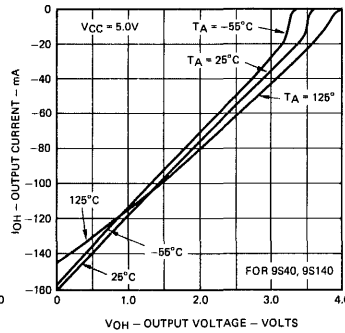

INPUT CURRENT VERSUS INPUT VOLTAGE

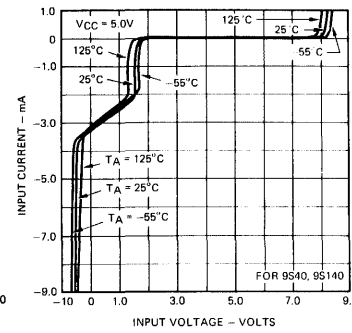

OUTPUT VOLTAGE VERSUS INPUT VOLTAGE

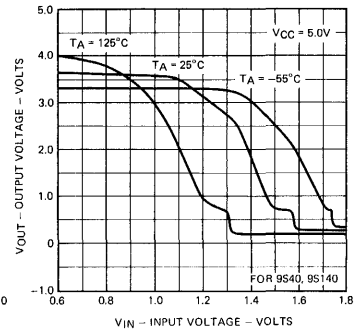

TYPICAL PROPAGATION DELAY TIME CHARACTERISTICS FOR 9S GATES, BUFFER, AND INVERTER

PROPAGATION DELAY TIME, LOW-TO-HIGH LEVEL OUTPUT VERSUS FREE-AIR TEMPERATURE

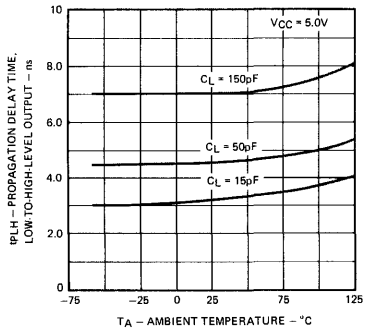

PROPAGATION DELAY TIME, LOW-TO-HIGH LEVEL OUTPUT VERSUS SUPPLY VOLTAGE

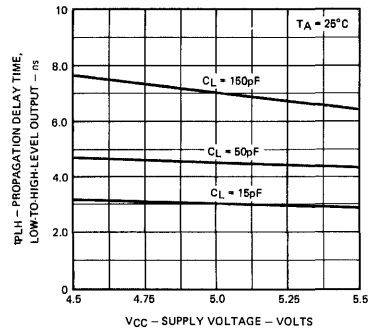

PROPAGATION DELAY TIME, HIGH-TO-LOW LEVEL OUTPUT VERSUS FREE-AIR TEMPERATURE

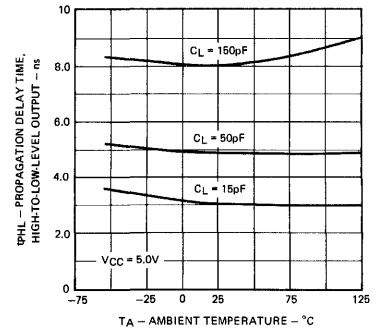

PROPAGATION DELAY TIME, HIGH-TO-LOW LEVEL OUTPUT VERSUS SUPPLY VOLTAGE

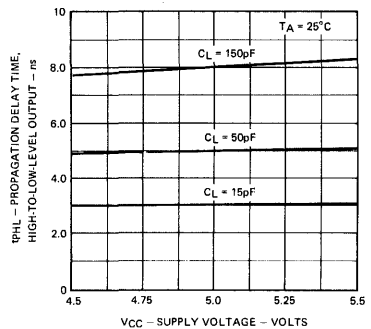

POWER DISSIPATION PER GATE VERSUS FREQUENCY

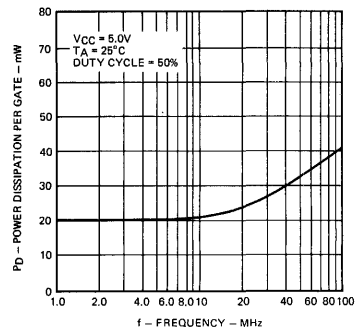

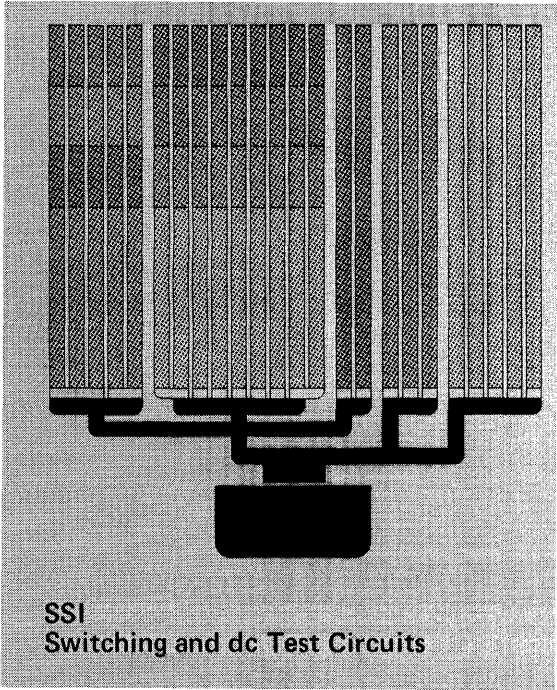

6

7

8

9

10

11

12

FAIRCHILD SERIES TTL/SSI

PARAMETER MEASUREMENT INFORMATION

DC TEST CIRCUITS*

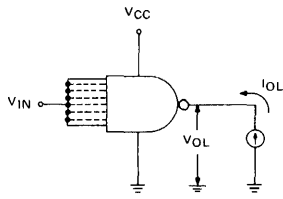

1. All inputs are tested simultaneously

Fig. 1

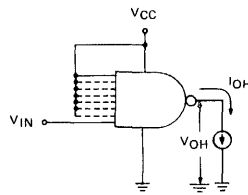

1. Each input is tested separately.

Fig. 2

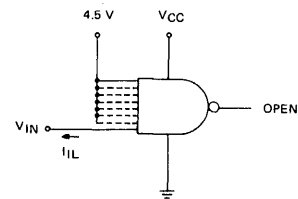

1. Each input is tested separately.

Fig. 3

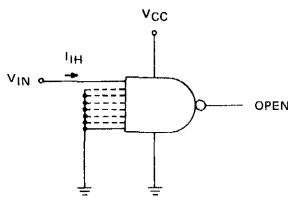

1. Each input is tested separately.

Fig. 4

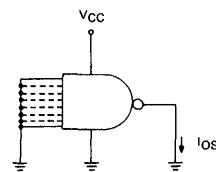

1. Each gate is tested separately.

Fig. 5

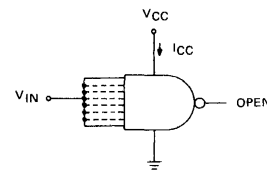

1. LOW level and HIGH level conditions are tested.
2. All gates are tested simultaneously.
3. Average supply current per gate:

$$I_{CC(AVG)} = \frac{I_{CCH} + I_{CCL}}{2 \times \text{No. of gates in package}}$$

Fig. 6

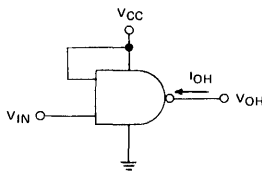

1. Each input is tested separately.

Fig. 7

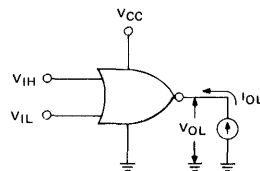

1. Each input is tested separately.

Fig. 8

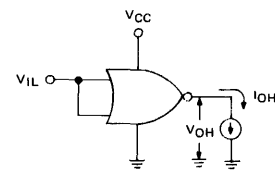

1. Both inputs are tested simultaneously.

Fig. 9

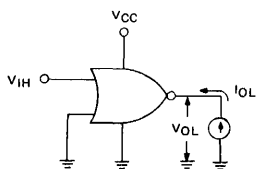

1. Each input is tested separately.

Fig. 10

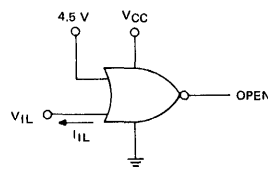

1. Each input is tested separately.

Fig. 11

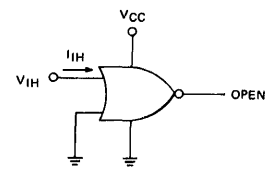

1. Each input is tested separately.

Fig. 12

* Arrows indicate actual direction of current flow.

FAIRCHILD SERIES TTL/SSI

PARAMETER MEASUREMENT INFORMATION

DC TEST CIRCUITS* (Continued)

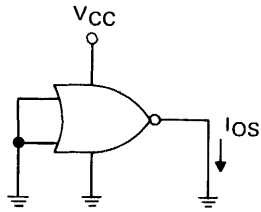

1. Each gate is tested separately.

Fig. 13

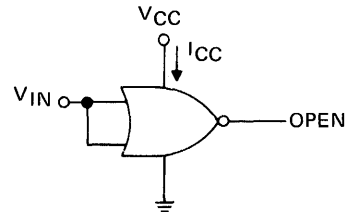

1. Low level and high level conditions are tested.
2. All gates are tested simultaneously.

Fig. 14

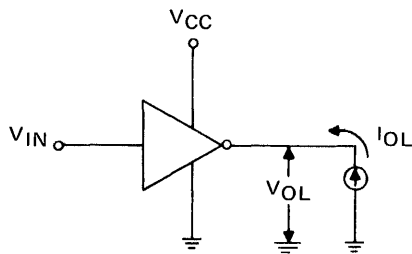

Fig. 15

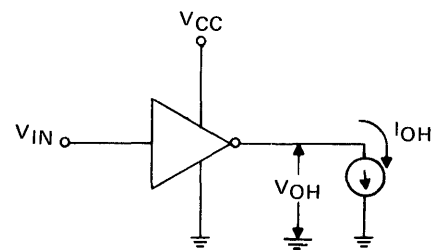

Fig. 16

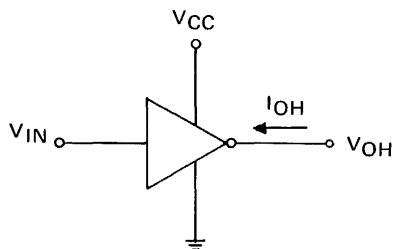

Fig. 17

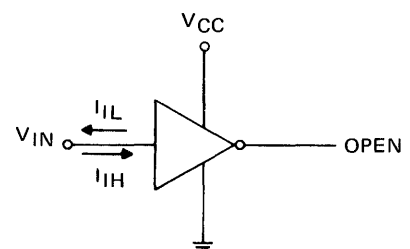
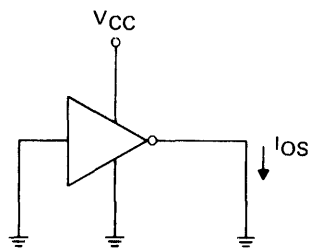
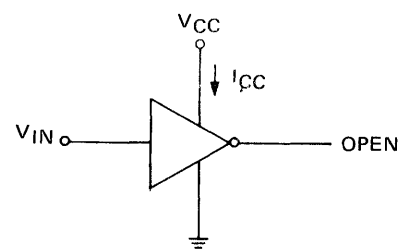

Fig. 18



1. Each inverter is tested separately.

Fig. 19



1. All inverters are tested simultaneously.

Fig. 20

*Arrows indicate actual direction of current flow.

FAIRCHILD SERIES TTL/SSI

PARAMETER MEASUREMENT INFORMATION

DC TEST CIRCUITS* (Continued)

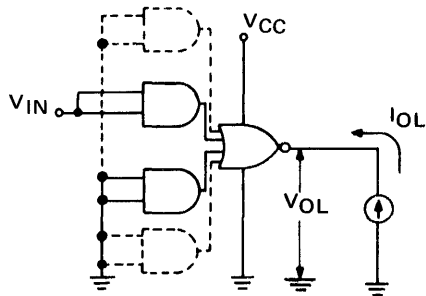

1. Each AND section is tested separately.

Fig. 21

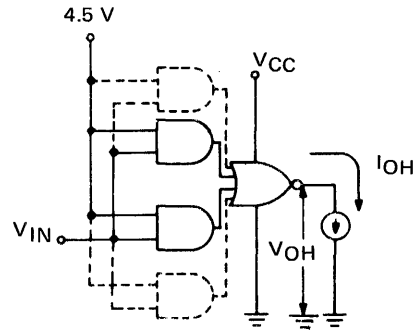

1. Each pair of inputs is tested separately.

Fig. 22

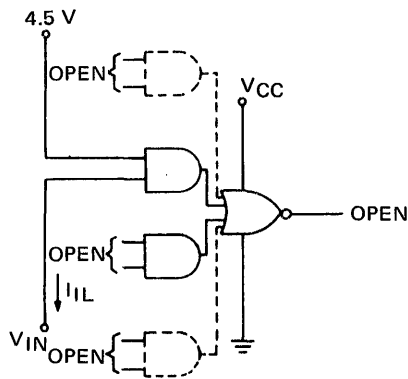

1. Each input is tested separately.

Fig. 23

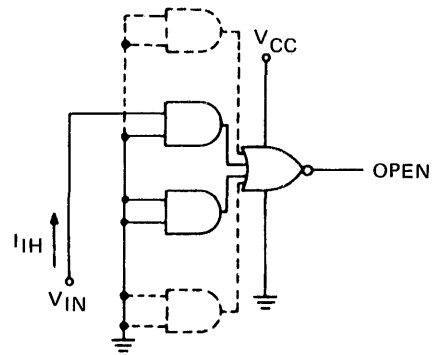

1. Each input is tested separately.

Fig. 24

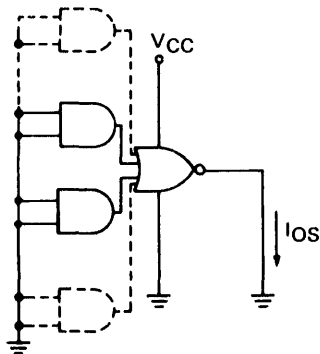

1. Each gate is tested separately.

Fig. 25

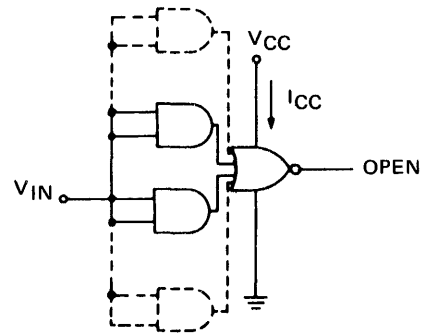

1. All gates are tested simultaneously.

Fig. 26

*Arrows indicate actual direction of current flow.

FAIRCHILD SERIES TTL/SSI

PARAMETER MEASUREMENT INFORMATION

DC TEST CIRCUITS* (Continued)

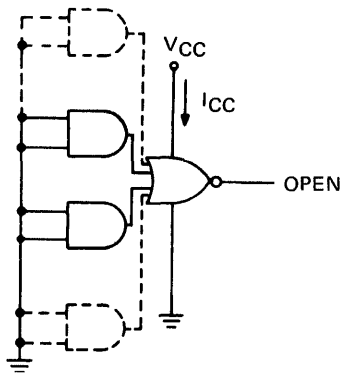

1. All gates are tested simultaneously

Fig. 27

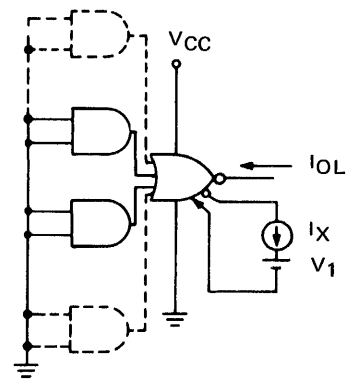

Fig. 28

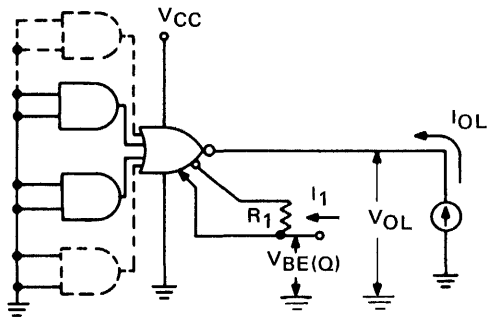

Fig. 29

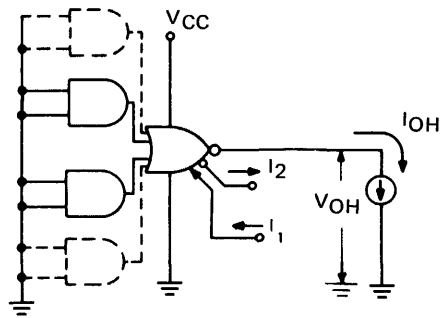
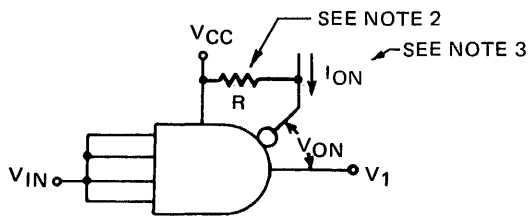
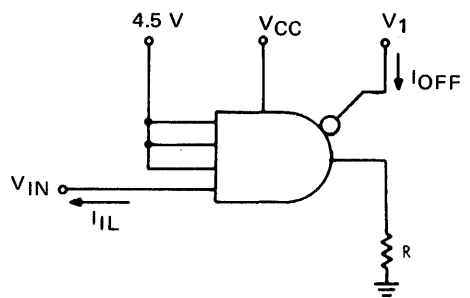

Fig. 30



1. All inputs are tested simultaneously.
 2. Deleted on 9H60/5460, 7460
 3. Deleted on 9N60/5460, 7460

Fig. 31



1. Each input is tested separately.

Fig. 32

* Arrows indicate actual direction of current flow.

FAIRCHILD SERIES TTL/SSI

PARAMETER MEASUREMENT INFORMATION

DC TEST CIRCUITS* (Continued)

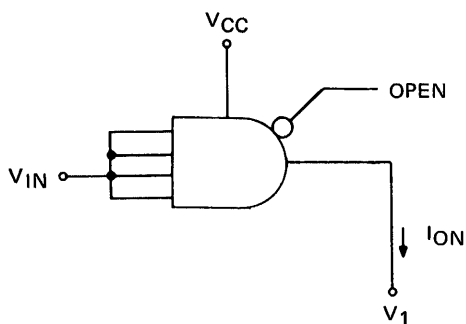
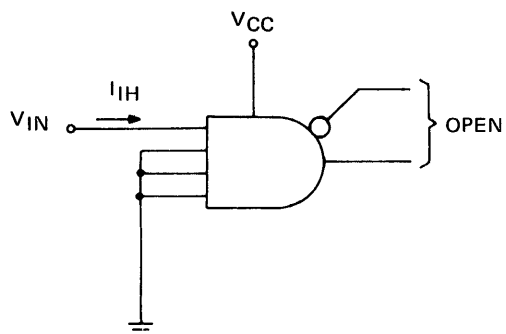
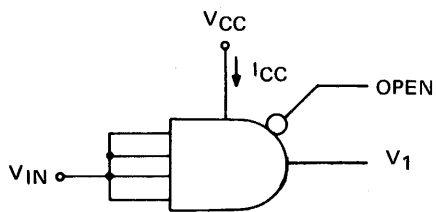

Fig. 33



1. Each input is tested separately.

Fig. 34



1. "On" and "off" conditions are tested separately.
2. All gates are tested simultaneously

Fig. 35

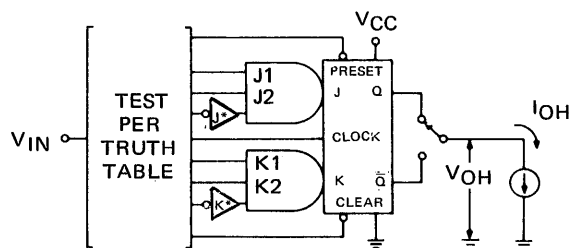

1. Each output is tested separately.
2. Preset and clear are tested with $V_{IN(clock)} = 0$.

Fig. 36

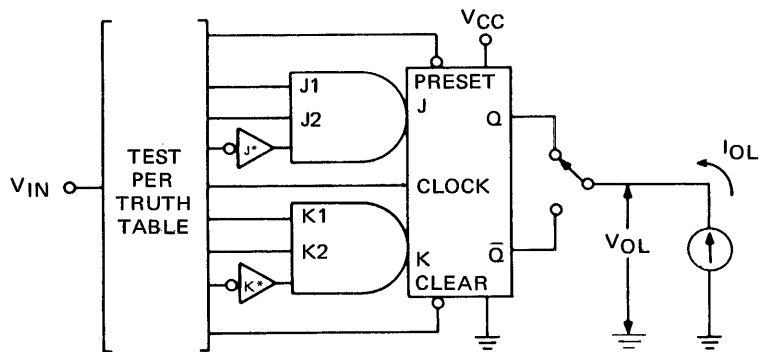

1. Each output is tested separately.

Fig. 37

*Arrows indicate actual direction of current flow.

FAIRCHILD SERIES TTL/SSI

PARAMETER MEASUREMENT INFORMATION

DC TEST CIRCUITS* (Continued)

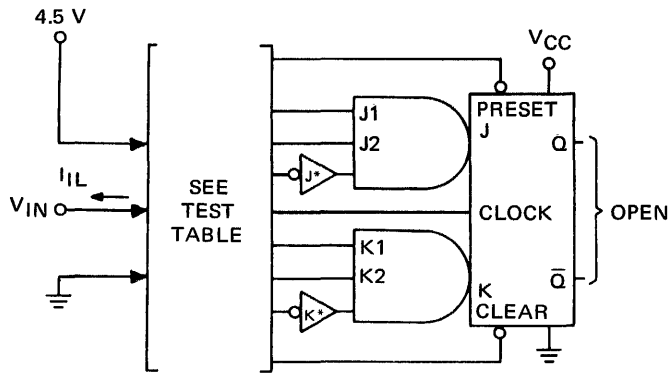

TEST TABLE

Apply V_{IN} (Test I_{IL})	Apply 4.5 V	Ground	Apply Momentary GND, then 4.5 V
J2	J1	J*	Clear
J1	J2	J*	Clear
J*	None	None	None
K2	K1	K*	Preset
K1	K2	K*	Preset
K*	None	None	None
Clock	None	None	None
Preset	K1 and K2	K*	None
Clear	J1 and J2	J*	None

1. Each output is tested separately.

Fig. 38

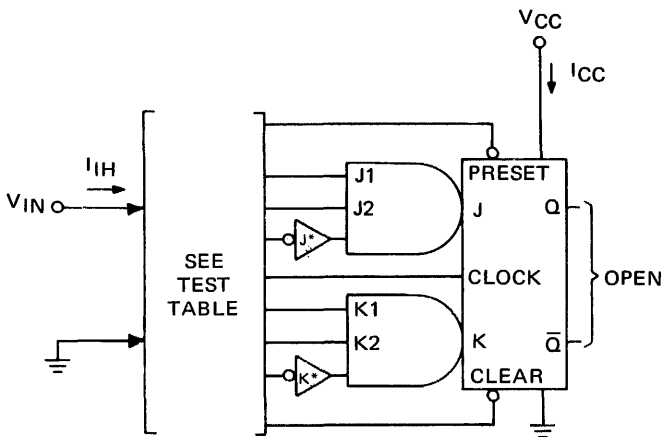

TEST TABLE

Apply V_{IN} (Test I_{IH})	Ground	Apply 4.5 V
J2	J1 and Clear	J*
J1	J2 and Clear	J*
J*	None	None
K2	K1 and Preset	K*
K1	K2 and Preset	K*
K*	None	None
Clock	None	None
Preset	K1 and K2	K*
Clear	J1 and J2	J*

1. Each input is tested separately.
2. I_{CC} is measured with clear at GND, then with preset at GND.

Fig. 39

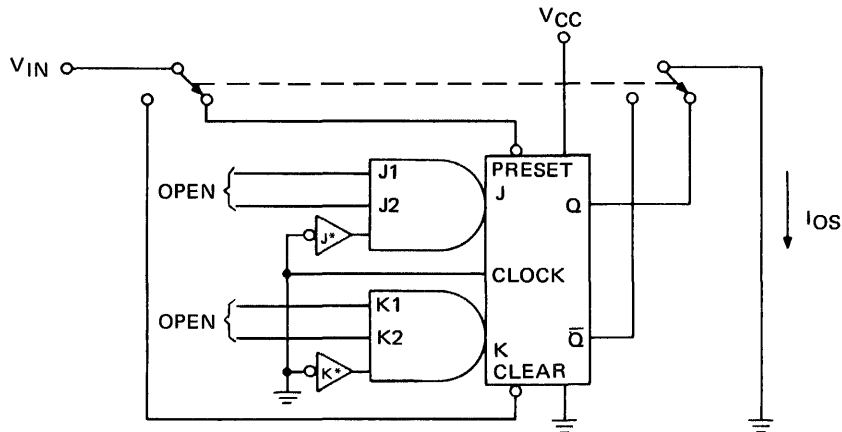

1. Each output is tested separately.

Fig. 40

* Arrows indicate actual direction of current flow.

FAIRCHILD SERIES TTL/SSI

PARAMETER MEASUREMENT INFORMATION

DC TEST CIRCUITS* (Continued)

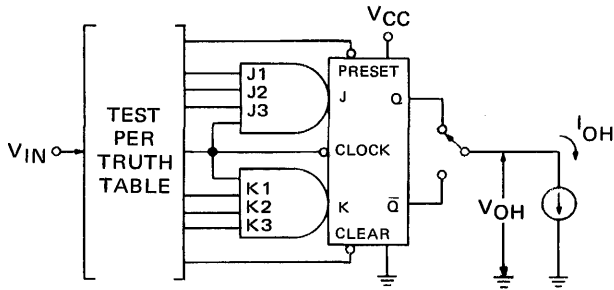

1. Each output is tested separately.

Fig. 41

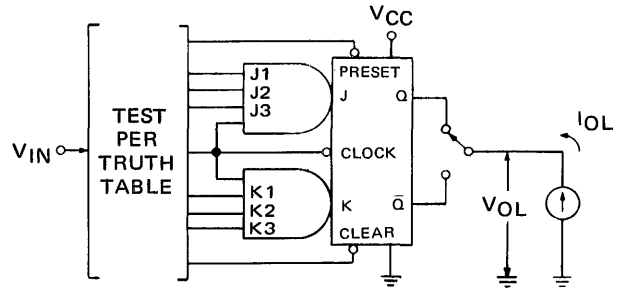

1. Each output is tested separately.

Fig. 42

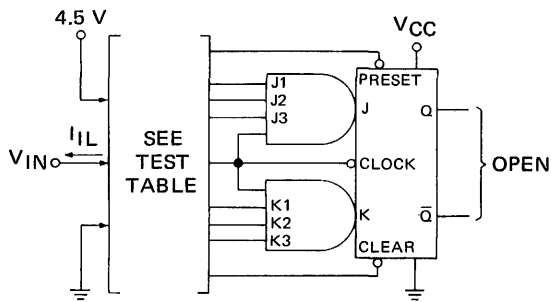

1. Each input is tested separately.

Fig. 43

TEST TABLE

Apply V_{IN} (Test I_{IL})	Apply Momentary GND, then 4.5 V	Apply 4.5 V
Clock	Preset	J1, J2, J3, K1, K2, and K3
Clock	Clear	J1, J2, J3, K1, K2, and K3
Preset	None	J1, J2, J3, K1, K2, and K3
Clear	None	J1, J2, J3, K1, K2, and K3
J1	Clear	Clock, J2, and J3
J2	Clear	Clock, J1, and J3
J3	Clear	Clock, J1, and J2
K1	Preset	Clock, K2, and K3
K2	Preset	Clock, K1, and K3
K3	Preset	Clock, K1, and K2

9H102/54H102, 74H102

Apply V_{IN} (Test I_{IL})	Apply 4.5 V	Ground
Clock	J1, J2, J3, K1, K2, K3, Clear	Preset
Clock	J1, J2, J3, K1, K2, K3, Preset	Clear
Preset	J1, J2, J3, K1, K2, K3, Clock, Clear	None
Clear	J1, J2, J3, K1, K2, K3, Clock, Preset	None
J1	J2, J3, K1, K2, K3, Clock, Preset	Clear
J2	J1, J3, K1, K2, K3, Clock, Preset	Clear
J3	J1, J3, K1, K2, K3, Clock, Preset	Clear
K1	J1, J2, J3, K2, K3, Clock, Clear	Preset
K2	J1, J2, J3, K1, K3, Clock, Clear	Preset
K3	J1, J2, J3, K1, K2, Clock, Clear	Preset

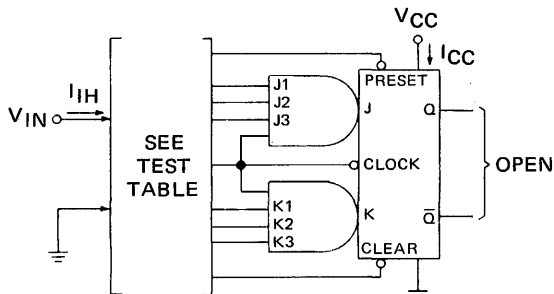

1. Each input is tested separately.
2. I_{CC} is measured with clear at GND, then with preset at GND.

Fig. 44

TEST TABLE

Apply V_{IN} (Test I_{IH})	Ground
Clock	Preset, Clear, J1, J2, J3, K1, K2, and K3
Preset	Clock, K1, K2, and K3
Clear	Clock, J1, J2, and J3
J1	Clock, Clear, J2, and J3
J2	Clock, Clear, J1, and J3
J3	Clock, Clear, J1, and J2
K1	Clock, Preset, K2, and K3
K2	Clock, Preset, K1, and K3
K3	Clock, Preset, K1, and K2

9H102/54H102, 74H102

Apply V_{IN} (Test I_{IH})	Ground	4.5V
Clock	J1, J2, J3, K1, K2, K3, Preset	Clear
Clock	J1, J2, J3, K1, K2, K3, Clear	Preset
Preset [†]	J1, J2, J3, K1, K2, K3, \bar{Q}	Clock, Clear
Clear [†]	J1, J2, J3, K1, K2, K3, \bar{Q}	Clock, Preset
J1	J2, J3, Clock, Preset	K1, K2, K3, Clear
J2	J1, J3, Clock, Preset	K1, K2, K3, Clear
J3	J1, J2, Clock, Preset	K1, K2, K3, Clear
K1	K2, K3, Clock, Clear	J1, J2, J3, Preset
K2	K1, K3, Clock, Clear	J1, J2, J3, Preset
K3	K1, K2, Clock, Clear	J1, J2, J3, Preset

*Arrows indicate actual direction of current flow.

[†]Duration of this test should not exceed 1 second.

FAIRCHILD SERIES TTL/SSI

PARAMETER MEASUREMENT INFORMATION

DC TEST CIRCUITS* (Continued)

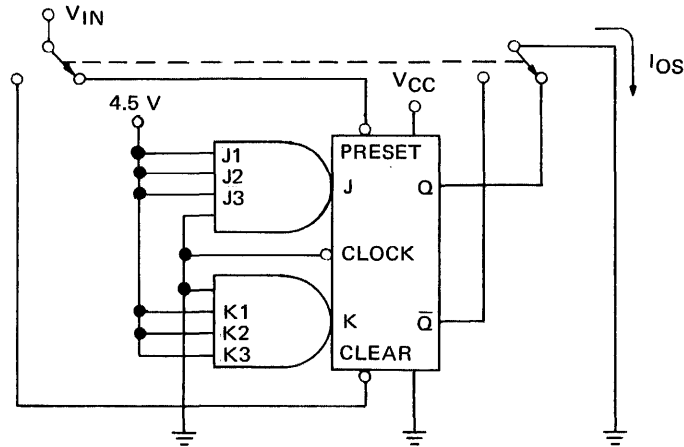

1. Each output is tested separately.

Fig. 45

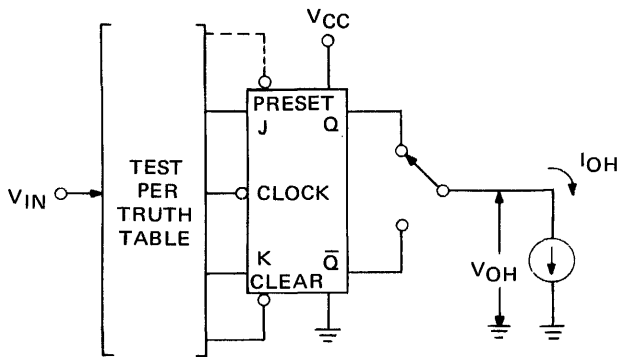

1. Each flip-flop is tested separately.
2. Each output is tested separately.
3. Preset is applicable for 9H78/54H78, 74H78 only.

Fig. 46

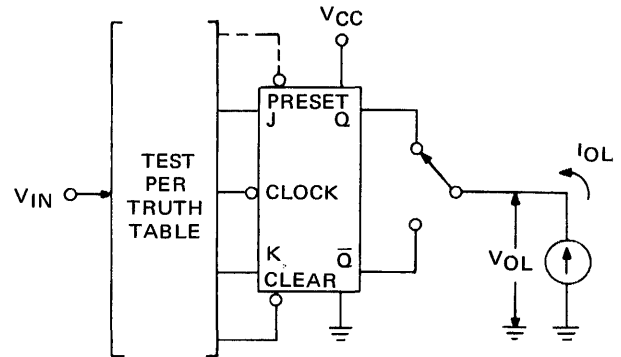

1. Each flip-flop is tested separately.
2. Each output is tested separately.
3. Preset is applicable for 9H78/54H78, 74H78 only.

Fig. 47

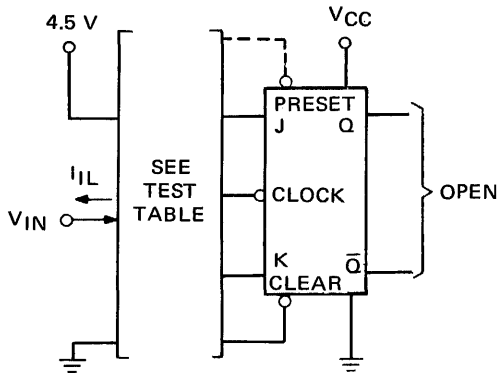

TEST TABLE

Apply V_{IN} (Test I_{IL})	Apply Momentary GND	Apply 4.5 V
Clock	Clear (See Note 2)	J and K
Clear	None	Clock and J
Preset	None (See Note 5)	Clock and K
J	Q (See Note 3)	Clock and Clear
K	\bar{Q} (See Note 3)	Clock and Clear

1. Each flip-flop is tested separately.
2. Apply momentary ground, then 4.5 V.
3. After application of momentary ground, Q and \bar{Q} are left floating.
4. Ground all inputs of the unused flip-flop.
5. Preset is applicable for 9N76/5476, 7476 circuits only.

Fig. 48

* Arrows indicate actual direction of current flow.

FAIRCHILD SERIES TTL/SSI

PARAMETER MEASUREMENT INFORMATION

DC TEST CIRCUITS* (Continued)

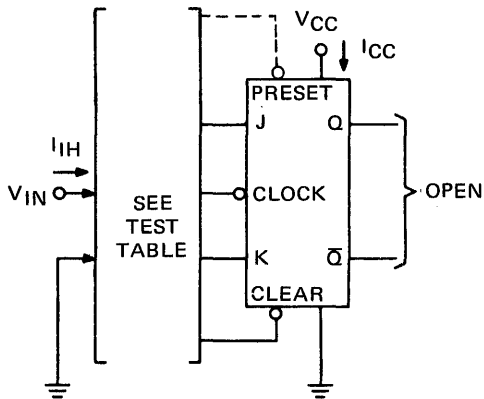
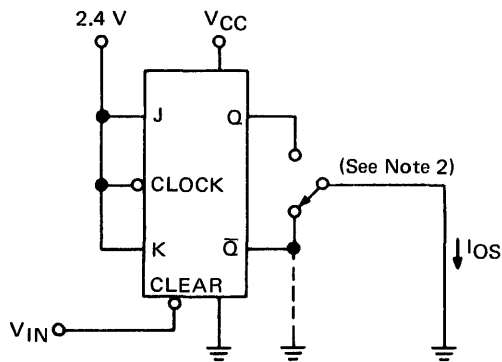

Fig. 49

TEST TABLE

Apply V_{IN} (Test I_{IH})	Ground	Apply Momentary GND, then 4.5 V
Clock	Clear, J, and K	None
Clear	Clock and J	None
Preset (See Note 1)	Clock and K	None
J (See Note 1)	Clock and Clear	Preset
K (See Note 1)	Clock and Preset	Clear

1. Preset is applicable for 9N76/5476, 7476 circuits only.
2. I_{CC} is measured (simultaneously for both flip-flops) for the following conditions:
 - a. $J = K = \text{Clock} = \text{Clear} = \text{GND}$. For 9N76/5476, 7476: Preset = 4.5 V.
 - b. For 9N73/5473, 7473: $J = \text{Clear} = 4.5 \text{ V}$, $K = \text{GND}$, and apply momentary 4.5 V, then GND to Clock. For 9N76/5476, 7476: $J = K = \text{Clock} = \text{Preset} = \text{GND}$, and Clear = 4.5 V.
3. Each flip-flop is tested separately for I_{IH} .



1. Each flip-flop is tested separately.
2. Test circuit shows setup for testing \bar{Q} . When testing \bar{Q} , apply 2.4 V to Clear, ground \bar{Q} , and limit duration of test to 100 ms.

Fig. 50

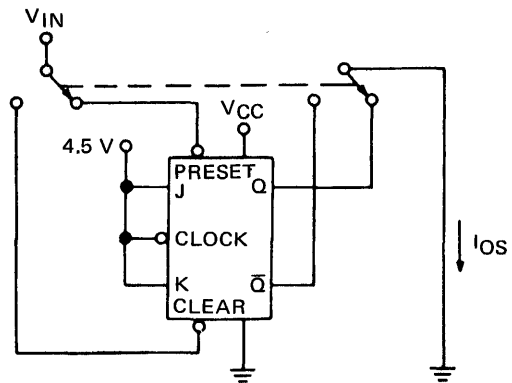

1. Each flip-flop is tested separately.

Fig. 51

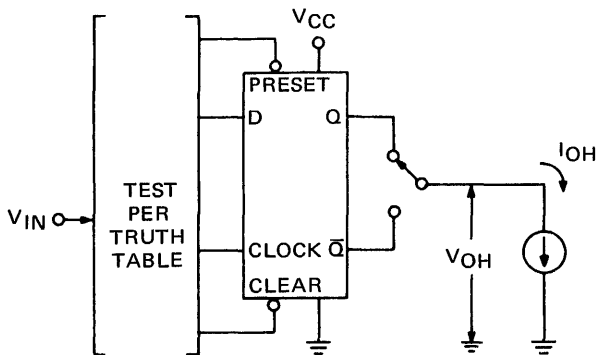

1. Each flip-flop is tested separately.
2. Each output is tested separately.

Fig. 52

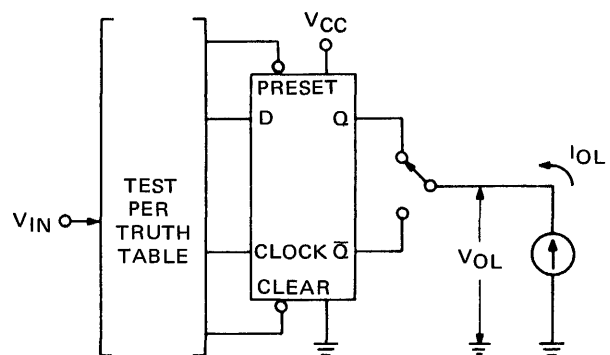

1. Each flip-flop is tested separately.
2. Each output is tested separately.

Fig. 53

* Arrows indicate actual direction of current flow.

FAIRCHILD SERIES TTL/SSI

PARAMETER MEASUREMENT INFORMATION

DC TEST CIRCUITS* (Continued)

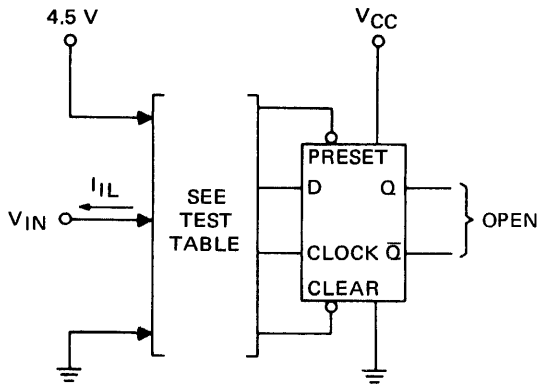

TEST TABLE

Apply V_{IN} (Test I_{IL})	Apply 4.5 V	Apply GND
Clock	Clear	Preset and D
Preset	Clear	Clock and D
Clear	Clock, D, and Preset	None
D	Clear and Clock	Preset

1. Each flip-flop is tested separately.
2. Each input is tested separately.

Fig. 54

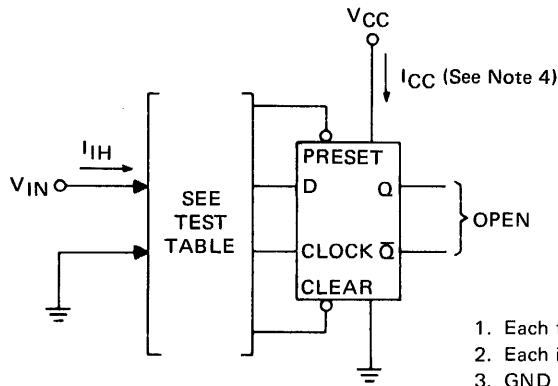

TEST TABLE

Apply V_{IN} (Test I_{IH})	Apply 4.5 V	Apply GND
Clock	Clear and D	Preset
Clock	Preset and D	Clear
Preset	Clear and D	Clock (See Note 3)
Clear	Preset	Clock, D, and Q
Clear	Preset	D and Clock (See Note 3)
D	Preset and Clock	Clear

1. Each flip-flop is tested separately.
2. Each input is tested separately.
3. GND is momentarily applied to clock, then 4.5V.
4. For 9N74/5474, 7474: I_{CC} is measured with D, clock, and preset at GND, then with D, clock, and clear at GND.
5. For 9H74/5474, 74H74: I_{CC} is measured simultaneously for both flip-flops with D, Clock, and Preset at GND, then with D, Clock, and Clear at GND.

Fig. 55

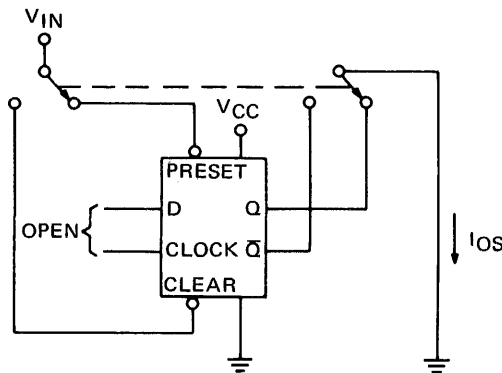

Each input is tested separately.

Fig. 56

* Arrows indicate actual direction of current flow.

FAIRCHILD SERIES TTL/SSI

PARAMETER MEASUREMENT INFORMATION

DC TEST CIRCUITS* (Continued)

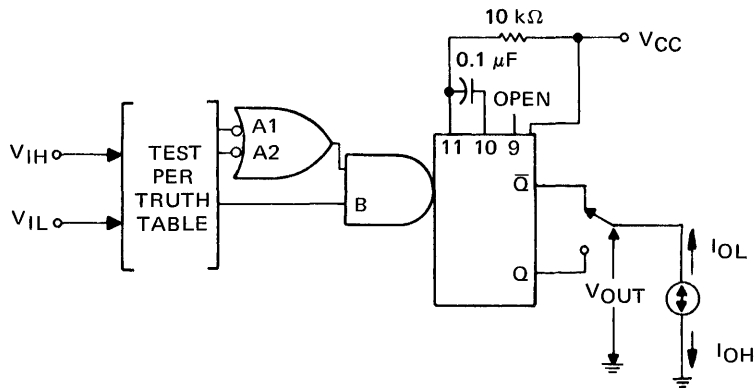
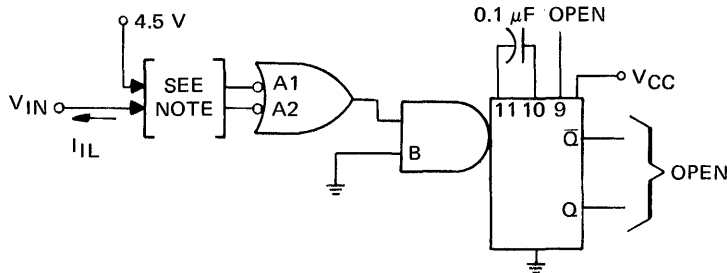

Fig. 57



1. Each input is tested separately. Input not being tested is at 4.5 V.

Fig. 58

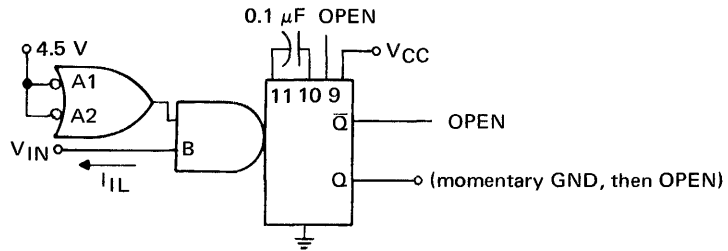
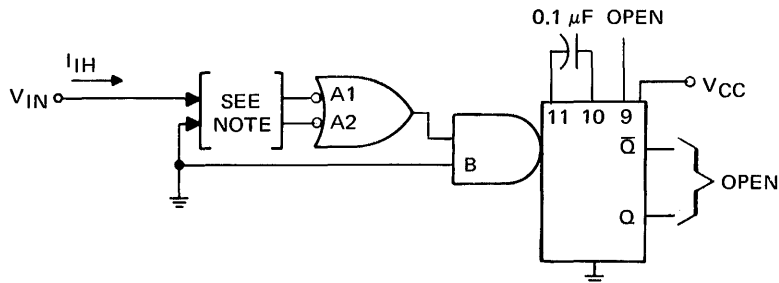

Fig. 59



1. Each input is tested separately. Input not being tested is at ground.

Fig. 60

* Arrows indicate actual direction of current flow.

FAIRCHILD SERIES TTL/SSI

PARAMETER MEASUREMENT INFORMATION

DC TEST CIRCUITS* (Continued)

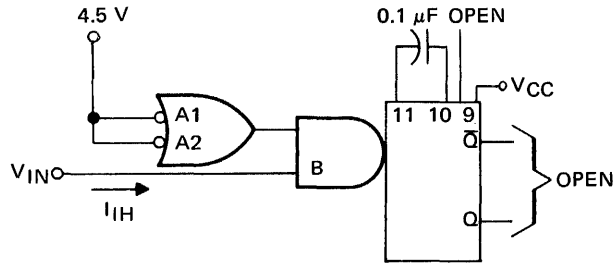
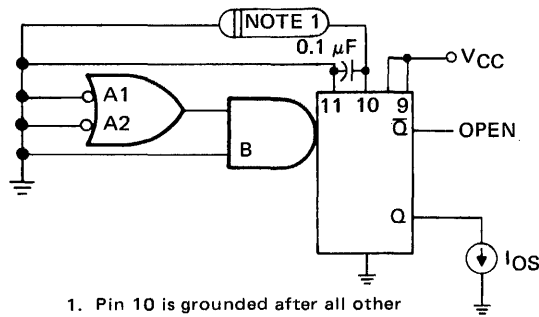

Fig. 61



1. Pin 10 is grounded after all other indicated grounds are made.

Fig. 62

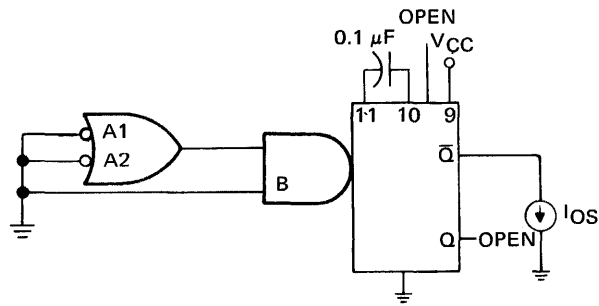
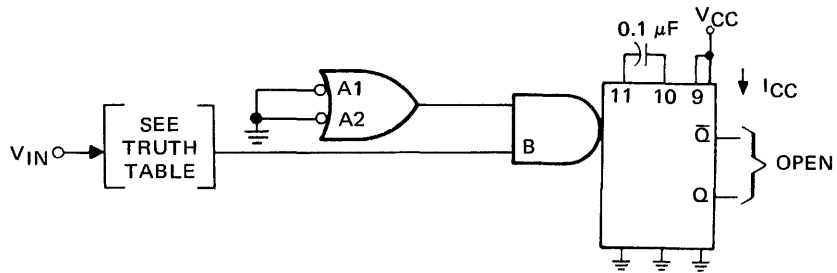

Fig. 63



1. Quiescent and fired conditions are tested.

Fig. 64

* Arrows indicate actual direction of current flow.

FAIRCHILD SERIES TTL/SSI

PARAMETER MEASUREMENT INFORMATION

DC TEST CIRCUITS* (Continued)

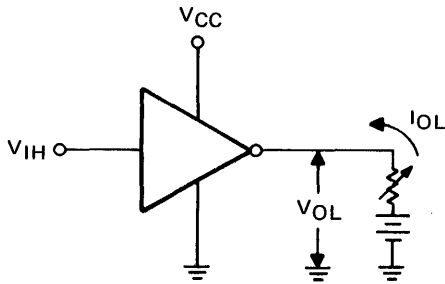

Fig. 65 V_{IH}, V_{OL}

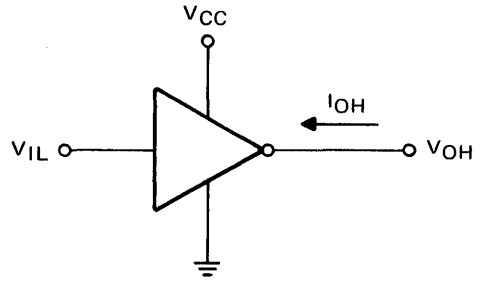

Fig. 66 V_{IL}, I_{OH}

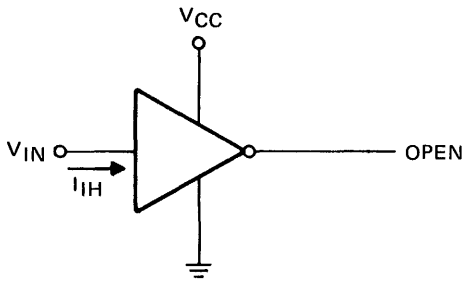

Fig. 67 I_{IH}

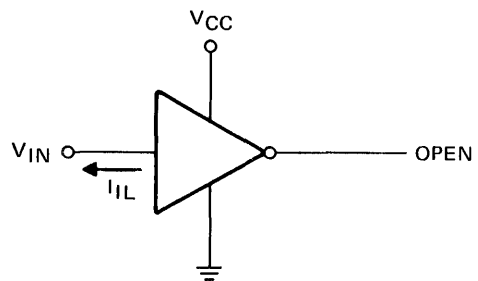
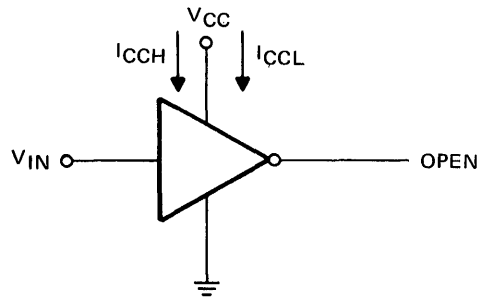

Fig. 68 I_{IL}



All inverters are tested simultaneously

Fig. 69 I_{CCH}, I_{CCL}

*Arrows indicate actual direction of current flow. Current into a terminal is a positive value.

FAIRCHILD SERIES TTL/SSI

PARAMETER MEASUREMENT INFORMATION

DC TEST CIRCUITS*

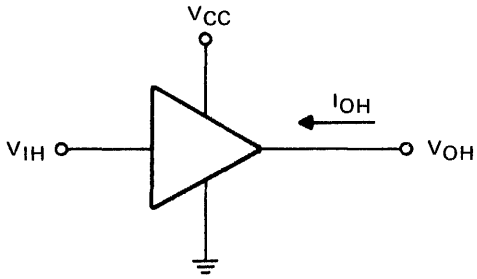

Fig. 70 V_{IH}, I_{OH}

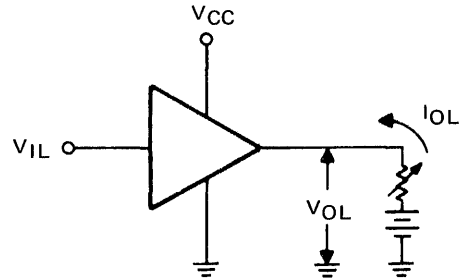

Fig. 71 V_{IL}, V_{OL}

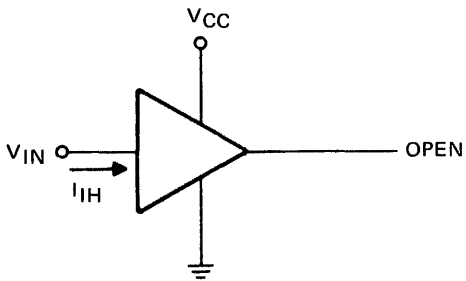

Fig. 72 I_{IH}

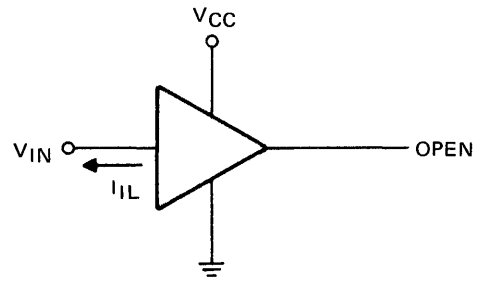
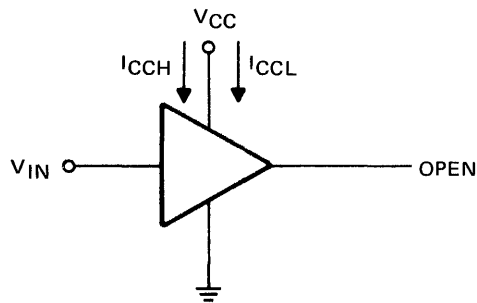

Fig. 73 I_{IL}



All buffers/drivers are tested simultaneously.

Fig. 74 I_{CCH}, I_{CCL}

*Arrows indicate actual direction of current flow. Current into a terminal is a positive value.

FAIRCHILD SERIES TTL/SSI

PARAMETER MEASUREMENT INFORMATION

DC TEST CIRCUITS* (Continued)

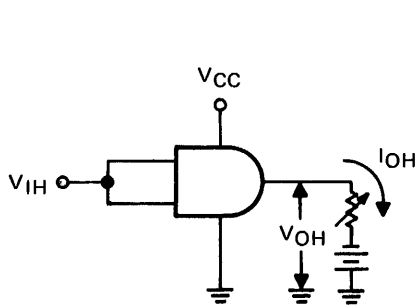

Both inputs are tested simultaneously.

Fig. 75 V_{IH}, V_{OH}

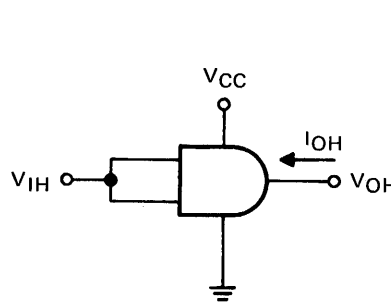
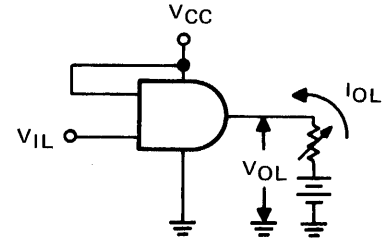
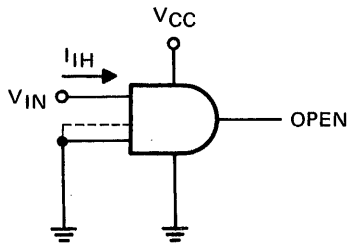

Fig. 76 V_{IH}, I_{OH}



Each input is tested separately.

Fig. 77 V_{IL}, V_{OL}



Each input is tested separately.

Fig. 78 I_{IH}

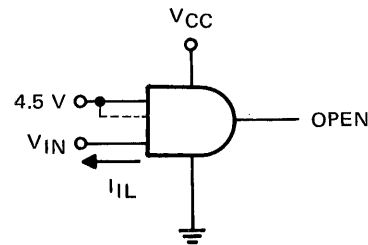

Each input is tested separately.

Fig. 79 I_{IL}

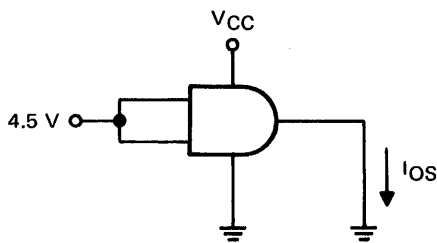

Each gate is tested separately.

Fig. 80 I_{OS}

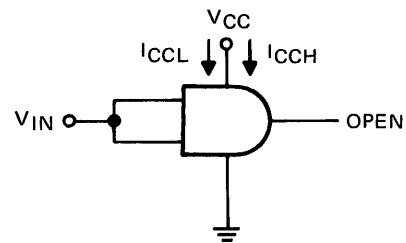

1. HIGH level and LOW level conditions are tested.
2. All gates are tested simultaneously.

Fig. 81 I_{CCH}, I_{CCL}

* Arrows indicate actual direction of current flow. Current into a terminal is a positive value.

FAIRCHILD SERIES TTL/SSI

PARAMETER MEASUREMENT INFORMATION

DC TEST CIRCUITS* (Continued)

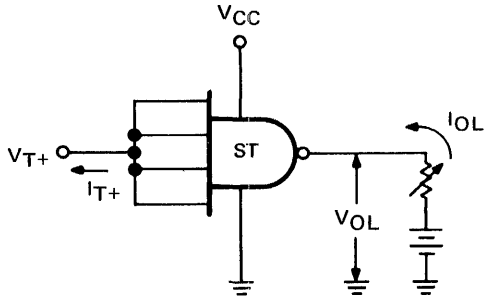

Fig. 82 V_{T+} , I_{T+} , V_{OL}

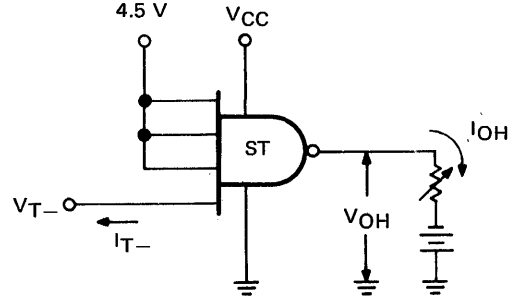
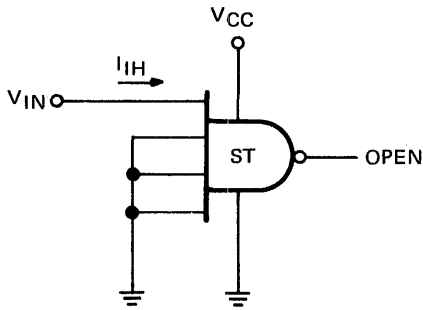
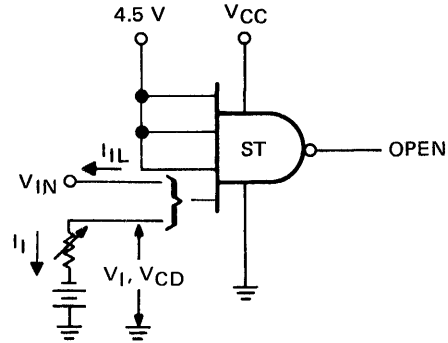

Fig. 83 V_{T-} , I_{T-} , V_{OH}



Each input is tested separately.

Fig. 84 I_{iH}



Each input is tested separately.

Fig. 85 V_i , V_{CE} , I_{iL}

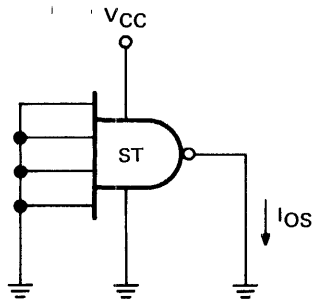

Each gate is tested separately.

Fig. 86 I_{OS}

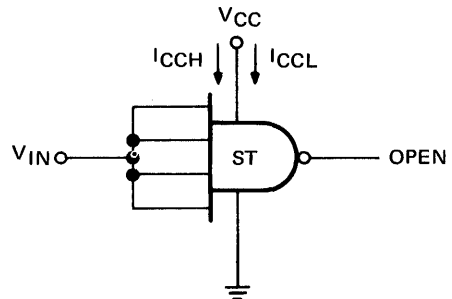

Fig. 87 I_{CCH} , I_{CCL}

* Arrows indicate actual direction of current flow. Current into a terminal is a positive value.

FAIRCHILD SERIES TTL/SSI

PARAMETER MEASUREMENT INFORMATION

DC TEST CIRCUITS* (Continued)

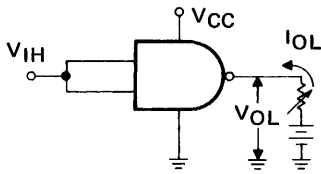

Both inputs are tested simultaneously

Fig. 88 V_{IH}, V_{OL}

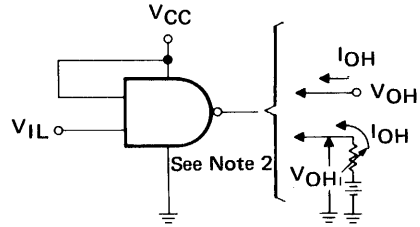

1. Each input is tested separately.
2. I_{OH} is tested at $V_{OH} = 12\text{ V}$ and V_{OH} is tested at $I_{OH} = 1\text{ mA}$.

Fig. 89 V_{IL}, V_{OH}, I_{OH}

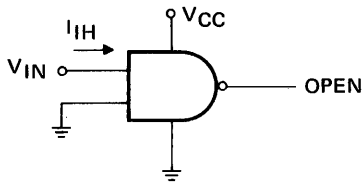

Each input is tested separately.

Fig. 90 I_{iH}

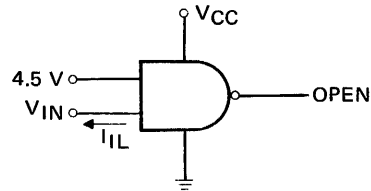

Each input is tested separately.

Fig. 91 I_{iL}

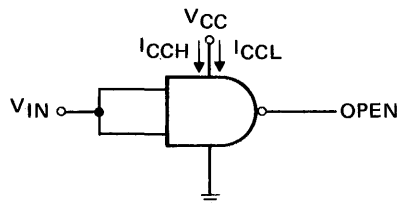

High-level and low-level output conditions are tested.

Fig. 92 I_{cCH}, I_{cCL}

*Arrows indicate actual direction of current flow. Current into a terminal is a positive value.

FAIRCHILD SERIES TTL/SSI

PARAMETER MEASUREMENT INFORMATION

DC TEST CIRCUITS* (Continued)

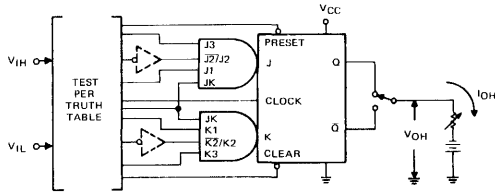

- NOTES:**
1. Each output is tested separately.
 2. V_{OH} is also tested using clear and preset inputs.

Fig. 93 V_{IH}, V_{IL}, V_{OH}

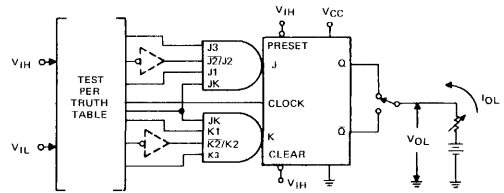

NOTE: Each output is tested separately.

Fig. 94 V_{IH}, V_{IL}, V_{OL}

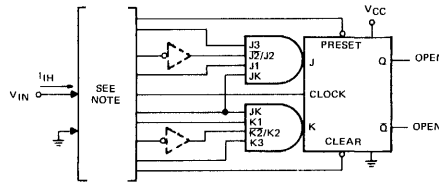

NOTE: V_{IN} is applied and I_{IH} is measured separately for each input. All other inputs are grounded.

Fig. 95 I_{IH}

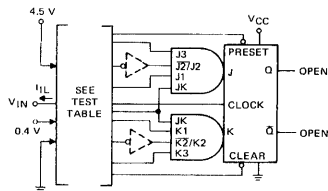

- NOTES:**
1. Each input is tested separately.
 2. V_{IN} is applied and I_{IL} is measured separately for each input.
 3. All unspecified inputs are at 4.5 V.

Fig. 96 I_{IL}

TEST TABLE

Apply V_{IN} (Test I_{IL})	CONDITIONS ON OTHER INPUTS	
	Apply 0.4 V	Apply GND
Clock	None	None
Preset	Clear	Clock
Clear	Preset	Clock
J1	$\overline{J2}$ (OR 4.5 V TO J2)	Clock, Clear
$\overline{J2}$ (OR J2)	None	Clock, Clear
J3	$\overline{J2}$ (OR 4.5 V TO J2)	Clock, Clear
JK	$\overline{J2}, K2$ (OR 4.5 V TO J2, K2)	Clock, Clear
JK	$\overline{J2}, K2$ (OR 4.5 V TO J2, K2)	Clock, Preset
K1	$\overline{K2}$ (OR 4.5 V TO K2)	Clock, Preset
$\overline{K2}$ (OR K2)	None	Clock, Preset
K3	$\overline{K2}$ (OR 4.5 V TO K2)	Clock, Preset

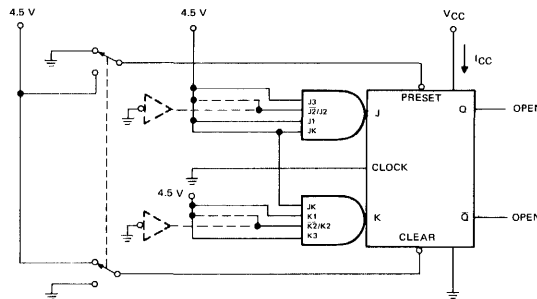

Fig. 97 I_{CC}

*Arrows indicate actual direction of current flow. Current into a terminal is a positive value.

FAIRCHILD SERIES TTL/SSI

PARAMETER MEASUREMENT INFORMATION

DC TEST CIRCUITS* (Continued)

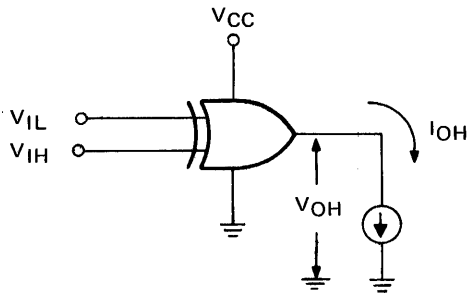

1. Each input is tested separately.

Fig. 98

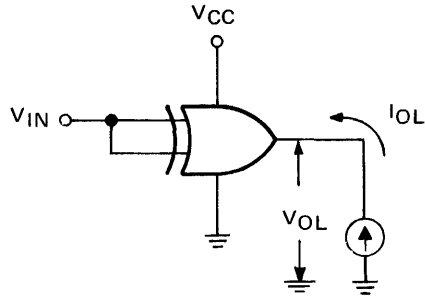

1. Low level and high level input conditions are tested.

Fig. 99

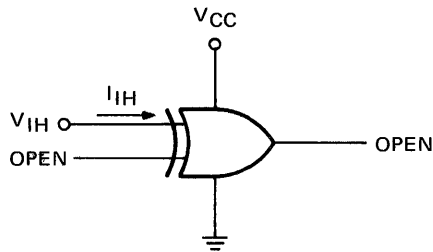

1. Each input is tested separately.

Fig. 100

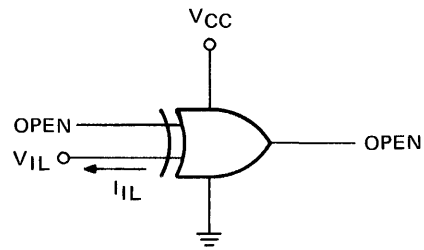

1. Each input is tested separately.

Fig. 101

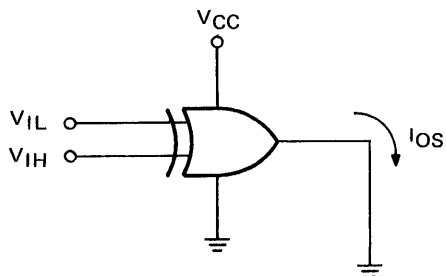

1. Each gate is tested separately.

Fig. 102

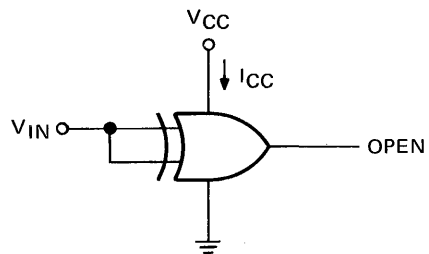

1. Low level and high level input conditions are tested.

Fig. 103

* Arrows indicate actual direction of current flow. Current into a terminal is a positive value.

FAIRCHILD SERIES TTL/SSI

PARAMETER MEASUREMENT INFORMATION

DC TEST CIRCUITS*

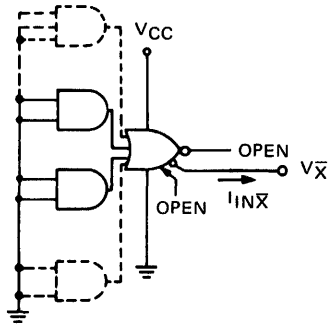
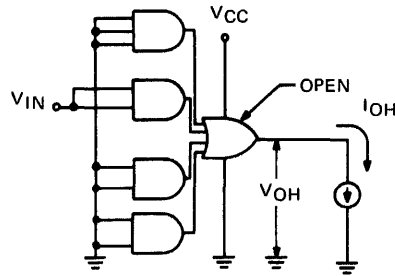
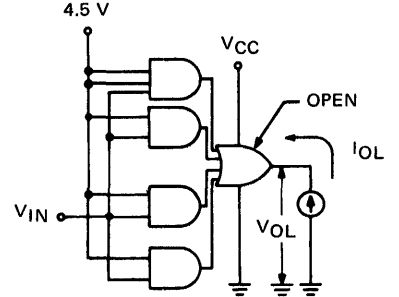

Fig. 104.



1. Each AND section is tested separately.

Fig. 105.



1. Each set of inputs is tested separately.

Fig. 106.

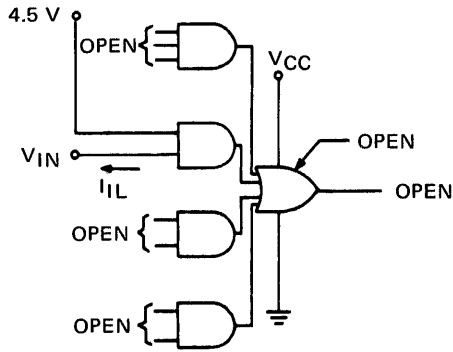

1. Each input of each AND section is tested separately.

Fig. 107.

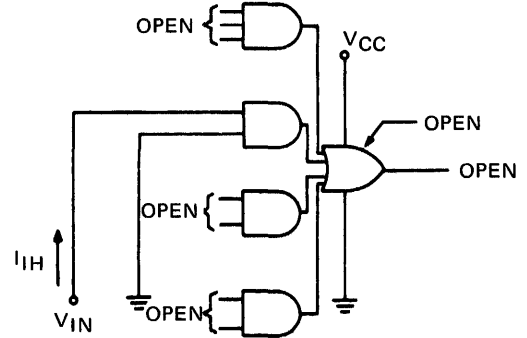

1. Each input of each AND section is tested separately.

Fig. 108.

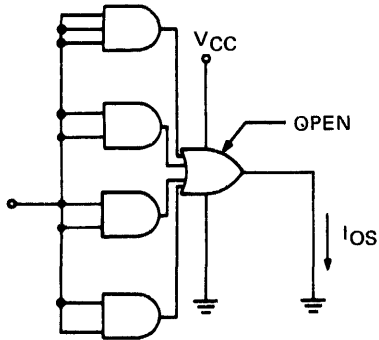
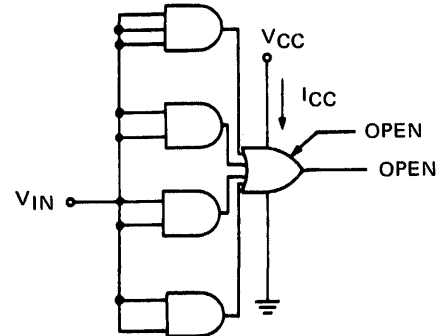

Fig. 109.



1. Logical 0 and logical 1 conditions are tested.

Fig. 110.

*Arrows indicate actual direction of current flow.

FAIRCHILD SERIES TTL/SSI

PARAMETER MEASUREMENT INFORMATION

DC TEST CIRCUITS* (Continued)

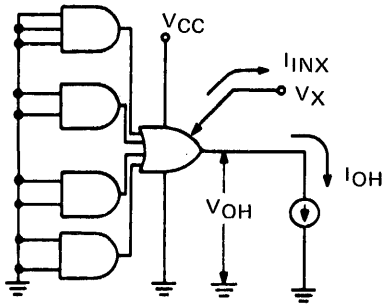

Fig. 111.

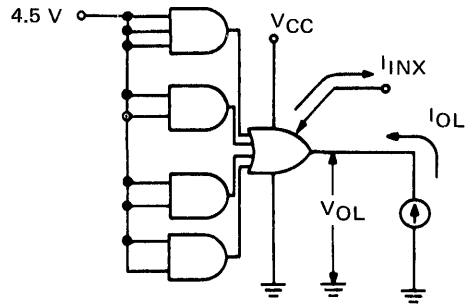
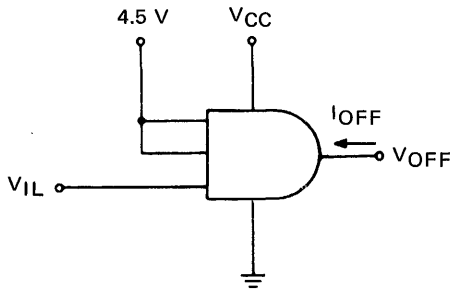
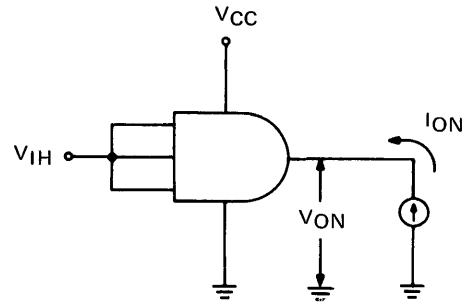

Fig. 112.



1. Each input is tested separately.

Fig. 113.



1. All inputs are tested simultaneously.

Fig. 114.

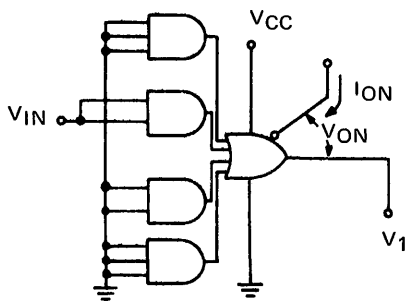

1. Each AND section is tested separately.

Fig. 115.

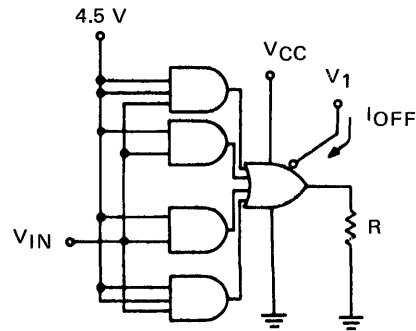

1. Each set of inputs is tested separately.

Fig. 116.

* Arrows indicate actual direction of current flow.

FAIRCHILD SERIES TTL/SSI

PARAMETER MEASUREMENT INFORMATION

DC TEST CIRCUITS* (Continued)

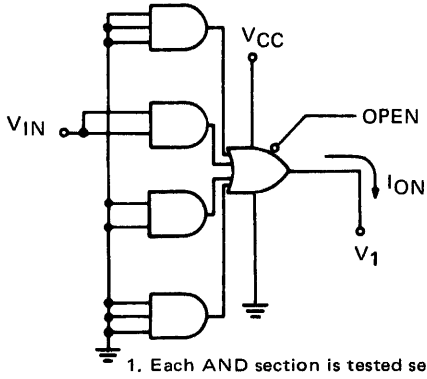

Fig. 117.

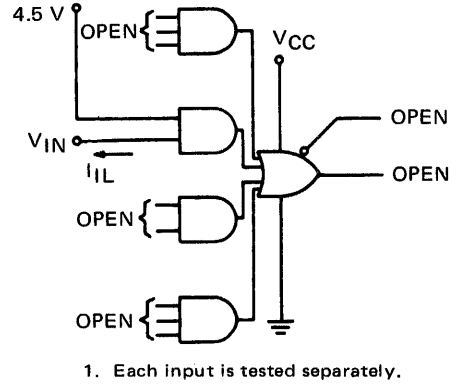

Fig. 118.

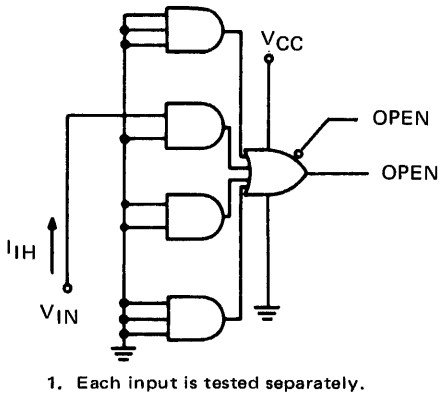

Fig. 119.

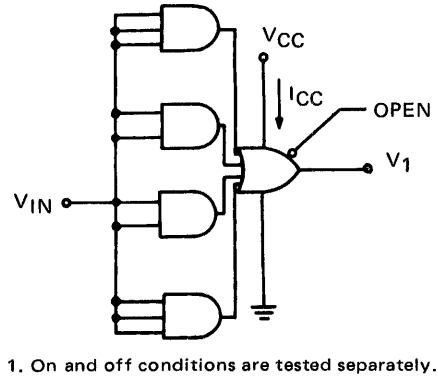

Fig. 120.

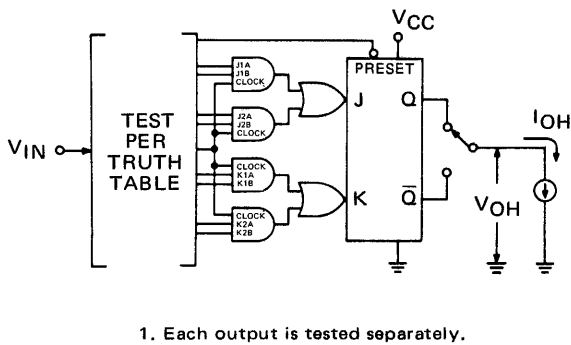

Fig. 121.

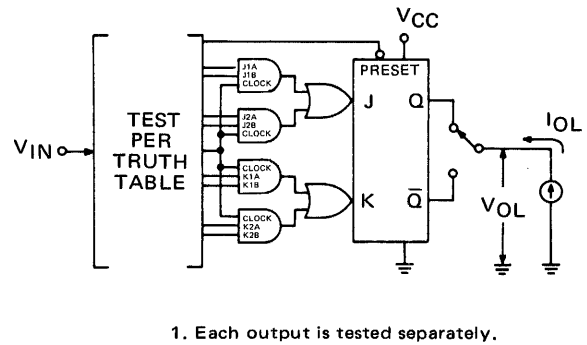

Fig. 122.

* Arrows indicate actual direction of current flow.

FAIRCHILD SERIES TTL/SSI

PARAMETER MEASUREMENT INFORMATION

DC TEST CIRCUITS* (Continued)

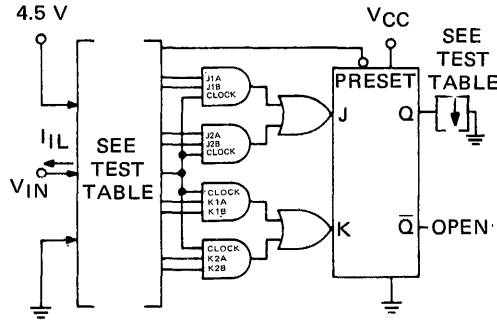

1. Each input is tested separately.

TEST TABLES^(a)

9H71/54H71, 74H71

Apply V_{IN} (Test I_{IL})	Apply 4.5 V	Apply Momentary GND then 4.5 V	GND
Clock	J1A, J1B, J2A, J2B, K1A, K1B, K2A, and K2B	Preset	None
Clock(b)	J1A, J1B, J2A, J2B, K1A, K1B, K2A, K2B, and Preset	None	Q
Preset	J1A, J1B, J2A, J2B, K1A, K1B, K2A, K2B, and Clock	None	None
J1A(b)	J1B and Clock	None	Q
J1B(b)	J1A and Clock	None	Q
J2A(b)	J2B and Clock	None	Q
J2B(b)	J2A and Clock	None	Q
K1A	K1B and Clock	Preset	None
K1B	K1A and Clock	Preset	None
K2A	K2B and Clock	Preset	None
K2B	K2A and Clock	Preset	None

9H101/54H101, 74H101

Apply V_{IN} (Test I_{IL})	Apply 4.5 V	Ground
Clock	J1A, J1B, J2A, J2B, K1A, K1B, K2A, K2B	Preset
Preset	J1A, J1B, J2A, J2B, K1A, K1B, K2A, K2B, Clock	None
J1A(b)	J1B, J2A, J2B, K1A, K1B, K2A, K2B, Clock, Preset	Q
J1B(b)	J1A, J2A, J2B, K1A, K1B, K2A, K2B, Clock, Preset	Q
J2A(b)	J1A, J1B, J2B, K1A, K1B, K2A, K2B, Clock, Preset	Q
J2B(b)	J1A, J1B, J2A, K1A, K1B, K2A, K2B, Clock, Preset	Q
K1A	J1A, J1B, J2A, J2B, K1B, K2A, K2B, Clock	Preset
K1B	J1A, J1B, J2A, J2B, K1A, K2A, K2B, Clock	Preset
K2A	J1A, J1B, J2A, J2B, K1A, K1B, K2B, Clock	Preset
K2B	J1A, J1B, J2A, J2B, K1A, K1B, K2A, Clock	Preset

^(a) Inputs and outputs not specified are open.

^(b) Duration of this test should not exceed 1 second.

Fig. 123.

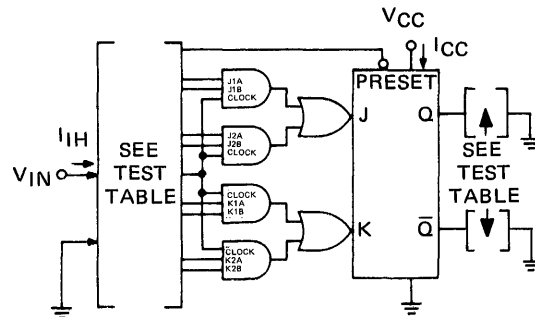

1. Each input is tested separately.

2. I_{CC} is measured for each of the following conditions:
A) J1A = J1B = J2A = J2B = K1A = K1B = K2A = K2B = Preset = 4.5 V, and Clock = momentary 4.5 V, then Gnd.

TEST TABLES^(a)

9H71/54H71, 74H71

Apply V_{IN} (Test I_{IH})	Ground
Clock	J1A, J1B, J2A, J2B, K1A, K1B, K2A, K2B, and Preset
Clock(b)	J1A, J1B, J2A, J2B, K1A, K1B, K2A, K2B, Preset and Q
Preset	K1A, K1B, K2A, K2B, Clock, and Q
J1A	J1B, Clock, and Preset
J1B	J1A, Clock, and Preset
J2A	J2B, Clock, and Preset
J2B	J2A, Clock, and Preset
K1A(b)	K1B, Clock, Preset, and Q
K1B(b)	K1A, Clock, Preset, and Q
K2A(b)	K2B, Clock, Preset, and Q
K2B(b)	K2A, Clock, Preset, and Q

9H101/54H101, 74H101

Apply V_{IN} (Test I_{IH})	Ground	Apply 4.5 V
Clock	J1A, J1B, J2A, J2B, K1A, K1B, K2A, K2B, Preset	None
Preset(b)	J1A, J1B, J2A, J2B, K1A, K1B, K2A, K2B, Q	Clock
J1A	J1B, J2A, J2B, Preset, Clock	K1A, K1B, K2A, K2B
J1B	J1A, J2A, J2B, Preset, Clock	K1A, K1B, K2A, K2B
J2A	J1A, J1B, J2B, Preset, Clock	K1A, K1B, K2A, K2B
J2B	J1A, J1B, J2A, Preset, Clock	K1A, K1B, K2A, K2B
K1A	K1B, K2A, K2B, Clock	Preset J1A, J1B, J2A, J2B
K1B	K1A, K2A, K2B, Clock	Preset J1A, J1B, J2A, J2B
K2A	K1A, K1B, K2B, Clock	Preset J1A, J1B, J2A, J2B
K2B	K1A, K1B, K2B, Clock	Preset J1A, J1B, J2A, J2B

^(a) Inputs and outputs not specified are open.

^(b) Duration of this test should not exceed 1 second.

Fig. 124.

* Arrows indicate actual direction of current flow.

FAIRCHILD SERIES TTL/SSI

PARAMETER MEASUREMENT INFORMATION

DC TEST CIRCUITS* (Continued)

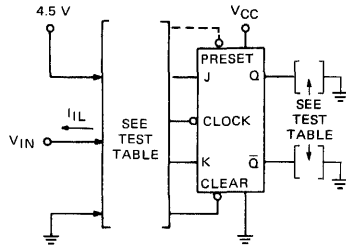

1. Each flip-flop is tested separately.
2. Apply momentary ground, then 4.5 V.
3. After application of momentary ground (<1 second), Q and \bar{Q} are left floating.
4. Ground all inputs of the unused flip-flop.
5. Preset is not applicable for 9H73/54H73, 74H73.
6. Apply the same conditions simultaneously to both flip-flops when testing the 9H108/54H108, 74H108.

TEST TABLES

9H73/54H73, 74H73 9H76/54H76, 74H76 9H78/54H78, 74H78		
Apply V_{IN} (Test I_{IL})	Apply Momentary GND	Apply 4.5 V
Clock	Clear (See Note 2)	J and K
Clear	None	Clock and J
Preset	None (See Note 5)	Clock and K
J	Q (See Note 3)	Clock and Clear
K	\bar{Q} (See Note 3)	Clock and Clear

9H103/54H103, 74H103		
Apply V_{IN} (Test I_{IL})	Apply GND	Apply 4.5 V
Clock	Clear	J, K
Clear	None	Clock, J, K
J	Clear	Clock, K
K^\dagger	Q	Clock, Clear, J

9H106/54H106, 74H106 9H108/54H108, 74H108		
Apply V_{IN} (Test I_{IL})	Apply GND	Apply 4.5 V
Clock	Clear	J, K, Preset,(Note 6)
Clear	Preset	J, K, Clear,(Note 6)
Clear	None	Clock, Preset, J, K,(Note 6)
Preset	None	Clock, Clear, J, K
J	Clear	Clock, K Preset
K	Preset	Clock, Clear, J

† Duration of this test should not exceed 1 second.

Fig. 125.

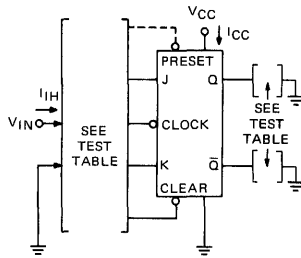

1. Preset is not applicable to 9H73/54H73, 74H73; 9H103/54H103, 74H103.
2. I_{CC} is measured (simultaneously for both flip-flops) for the following conditions:
 - a. J = K = Clock = Clear = Gnd.
Preset (when applicable) = 4.5 V.
 - b. For 9H73/54H73, 74H73 and 9H103/54H103, 74H103. J = Clear = 4.5 V, K = Gnd, and apply momentary 4.5 V, then Gnd, to Clock. For 9H76/54H76, 74H76; 9H78/54H78, 74H78; 9H108/54H108, 74H108: J = K = Clock = Preset = Gnd, and Clear = 4.5 V.
3. Each flip-flop is tested separately except where Note 4 is referenced.
4. Apply the same conditions to both flip-flops when testing the 9H108/54H108, 74H108.

TEST TABLES

9H73/54H73, 74H73 9H76/54H76, 74H76 9H78/54H78, 74H78		
Apply V_{IN} (Test I_{IH})	Ground	Apply Momentary GND, then 4.5 V
Clock	Clear, J, and K	None
Clear	Clock and J	None
Preset (See Note 1)	Clock and K	None
J (See Note 1)	Clock and Clear	Preset
K (See Note 1)	Clock and Preset	Clear

9H103/54H103, 74H103		
Apply V_{IN} (Test I_{IH})	Apply GND	Apply 4.5 V
Clock	Clear, J, K	None
Clear †	Q, J, K	Clock
J	Clock	Clear, K
K	Clock, Clear	J

9H106/54H106, 74H106 9H108/54H108, 74H108		
Apply V_{IN} (Test I_{IH})	Apply GND	Apply 4.5 V
Clock	Clear, J, K	Preset,(Note 4)
Clock	Preset, J, K	Clear,(Note 4)
Clear †	Q, J, K	Preset, Clock,(Note 4)
Preset †	\bar{Q} , J, K	Clear, Clock
J	Clock, Preset	Clear, K
K	Clock, Clear	Preset, J

Fig. 126.

† Duration of this test should not exceed 1 second.

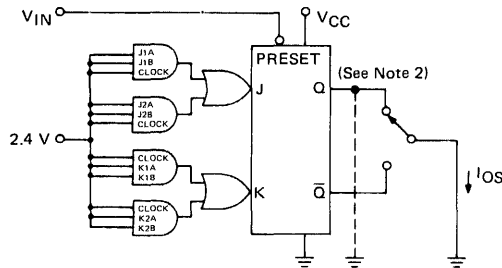

1. Each output is tested separately.
2. Test circuit shows setup for testing Q. When testing \bar{Q} , apply 2.4 V to Preset, ground Q, and limit duration of test to 100 ms.

Fig. 127.

FAIRCHILD SERIES TTL/SSI

PARAMETER MEASUREMENT INFORMATION

SWITCHING CHARACTERISTICS

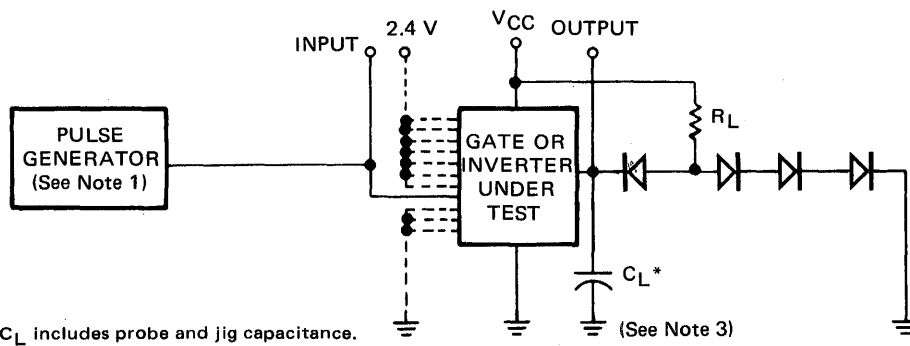

TEST CIRCUIT FOR 9N00/5400, 7400; 9N02/5402, 7402; 9N04/5404, 7404; 9N10/5410, 7410; 9N20/5420, 7420; 9N30/5430, 7430; 9N40/5440, 7440; 9N50/5450, 7450; 9N51/5451, 7451; 9N53/5453, 7453 and 9N54/5454, 7454

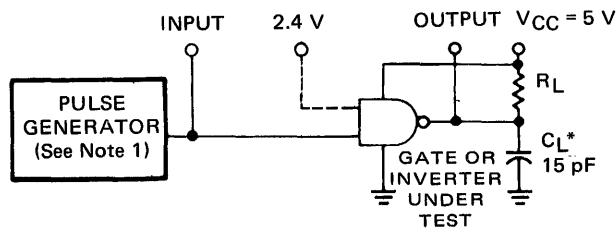

TEST CIRCUIT FOR 9N01/5401, 7401; 9N03/5403, 7403; 9N05/5405, 7405; 9N39/5439, 7439

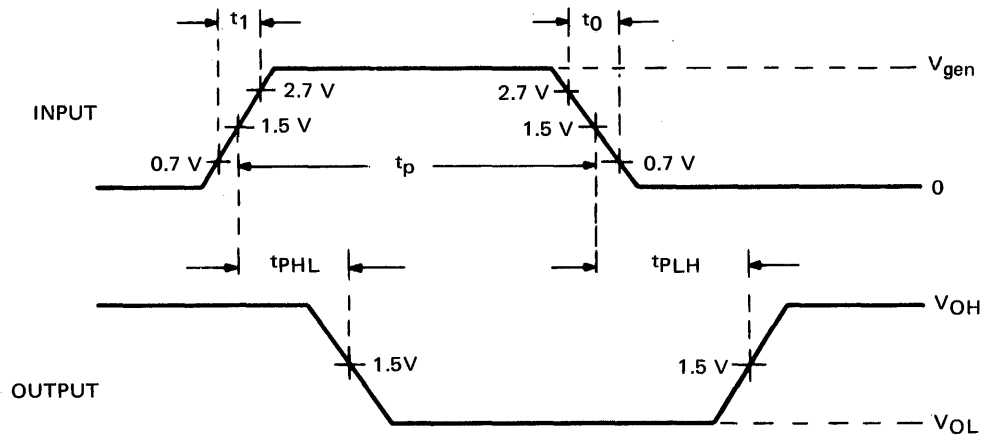

VOLTAGE WAVEFORMS

NOTES:

- The generator has the following characteristics: $V_{gen} = 3.5 \text{ V}$, $t_0 = 5 \text{ ns}$, $t_1 = 10 \text{ ns}$, $t_p = 0.5 \mu\text{s}$, $\text{PRR} = 1 \text{ MHz}$, $Z_{out} \approx 50 \Omega$.
- Propagation Delay = $\frac{t_{PHL} + t_{PLH}}{2}$
- When testing 9N00/5400, 7400 through 9N40/5440, 7440 (except 9N02/5402, 7402), connect all unused inputs to 2.4 V. When testing the 9N02/5402, 7402 or 9N50/5450, 7450 through 9N54/5454, 7454, apply the input pulse to one input of one AND section and 2.4 V to all unused inputs of that AND section. All inputs or unused AND sections are grounded.

Fig. A GATE PROPAGATION DELAY TIMES

FAIRCHILD SERIES TTL/SSI

PARAMETER MEASUREMENT INFORMATION

SWITCHING CHARACTERISTICS (Continued)

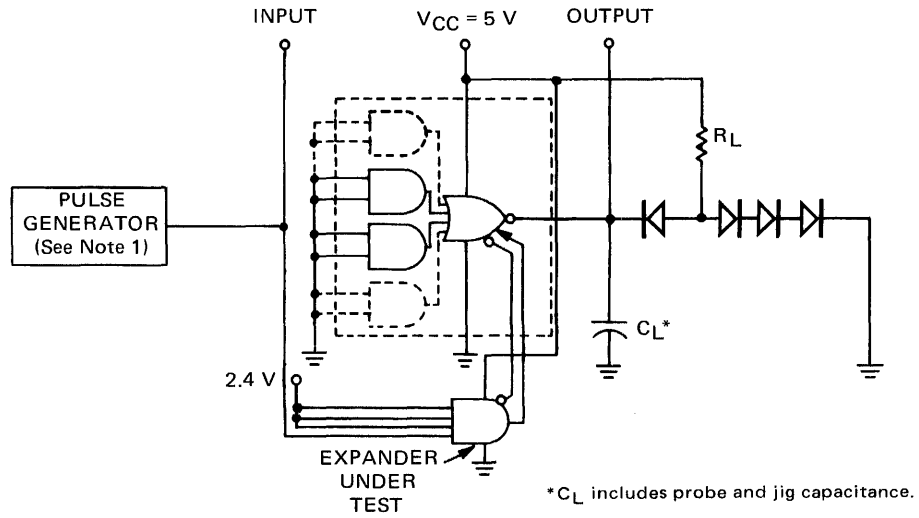

TEST CIRCUIT

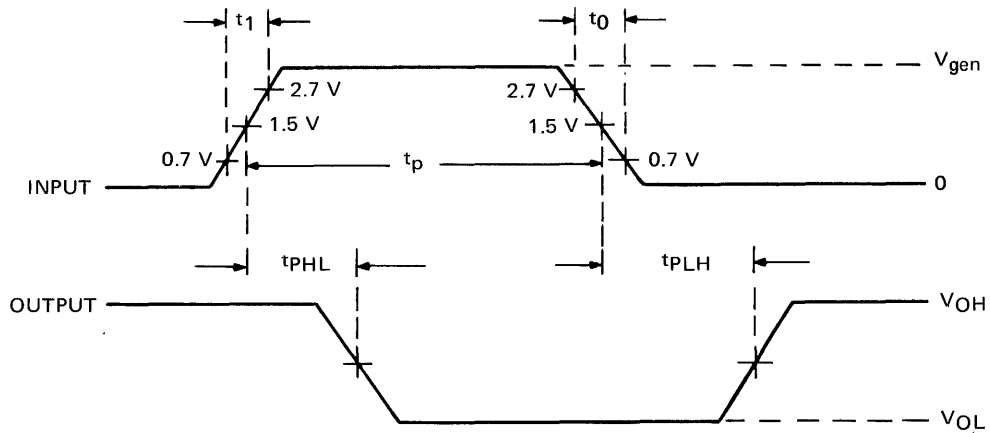

VOLTAGE WAVEFORMS

NOTES:

1. The generator has the following characteristics: $V_{gen} = 3.5 \text{ V}$, $t_0 = 5 \text{ ns}$, $t_1 = 10 \text{ ns}$, $t_p = 0.5 \mu\text{s}$, $\text{PRR} = 1 \text{ MHz}$, $Z_{out} \approx 50 \Omega$.
2. Propagation Delay = $\frac{t_{PHL} + t_{PLH}}{2}$

Fig. B EXPANDER PROPAGATION DELAY TIMES

FAIRCHILD SERIES TTL/SSI

PARAMETER MEASUREMENT INFORMATION

SWITCHING CHARACTERISTICS (Continued)

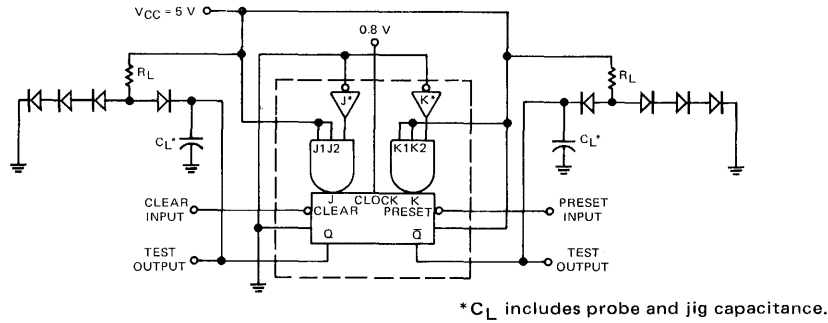

9N70/5470, 7470 TEST CIRCUIT

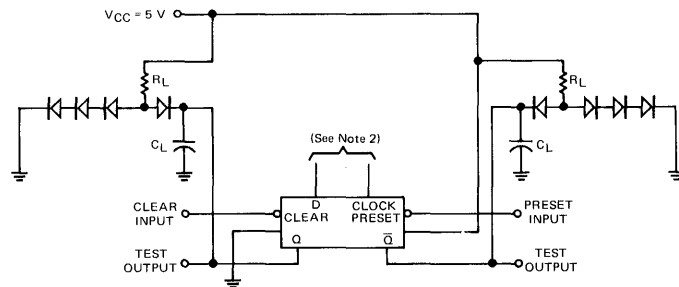

9N74/5474, 7474 TEST CIRCUIT

NOTES:

1. Preset or clear function of the 9N70/5470, 7470 can occur only when clock input is low. Gated inputs are inhibited.
2. Clear and preset inputs of the 9N74/5474, 7474 dominate regardless of the state of clock or D inputs.

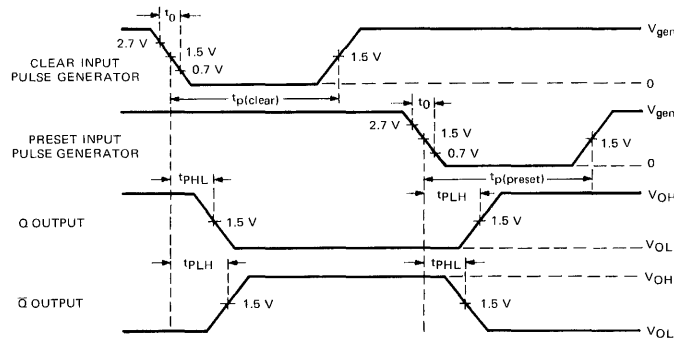

VOLTAGE WAVEFORMS

NOTE:

3. Clear or preset input pulse characteristics: $V_{gen} = 3.5\text{ V}$, $t_0 = 5\text{ ns}$, $t_p = 25\text{ ns}$ for the 9N70/5470, 7470 and $t_p = 30\text{ ns}$ for 9N74/5474, 7474.

Fig. C 9N70/5470, 7470 and 9N74/5474, 7474 PRESET/CLEAR PROPAGATION DELAY TIMES

FAIRCHILD SERIES TTL/SSI

PARAMETER MEASUREMENT INFORMATION

SWITCHING CHARACTERISTICS (Continued)

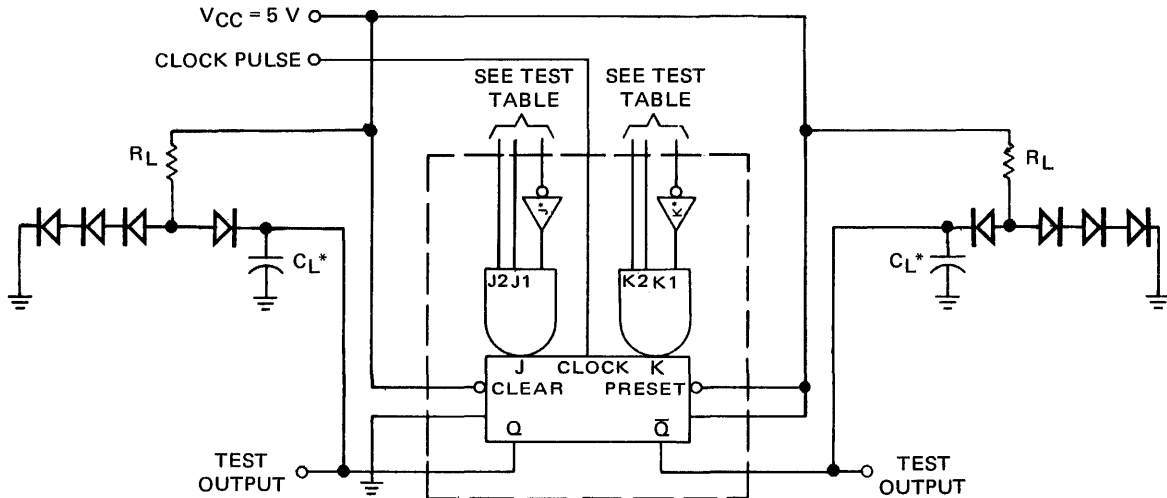

* C_L includes probe and jig capacitance.

TEST CIRCUIT

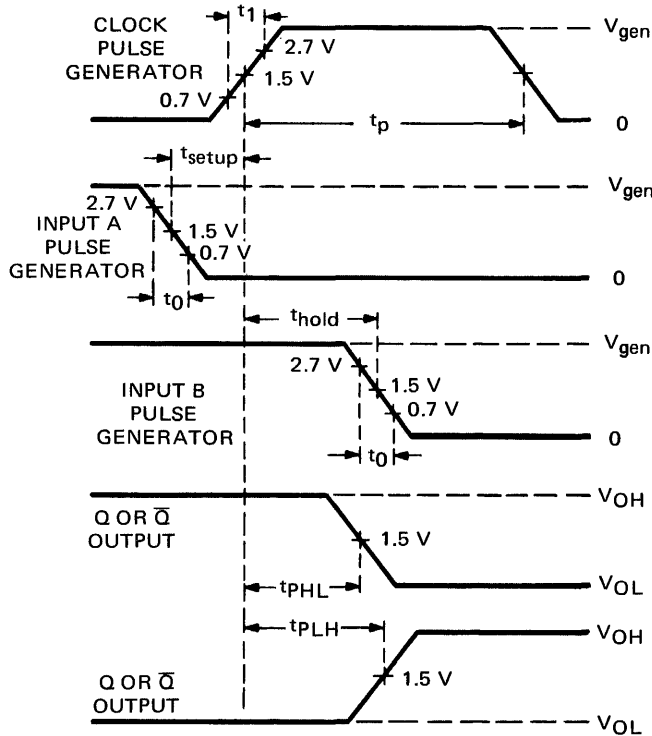

VOLTAGE WAVEFORMS

TEST TABLE

Test No.	Test	Input A	Input B	Apply 2.4 V	GND
1	t_{setup} at J*	J*	None	J1, J2, K1, K2	K*
2	t_{hold} at J1, J2	None	J1, J2	K1, K2	J* and K*
3	t_{setup} at K*	K*	None	J1, J2, K1, K2	J*
4	t_{hold} at K1, K2	None	K1, K2	J1, J2	J* and K*

NOTES:

1. Clock pulse (see note 3), input A, and input B are used to measure t_{setup} and t_{hold} .
2. Clock frequency, t_{PLH} and t_{PHL} (from clock to output) are measured in the toggle mode. Hold J = K = high level per truth table and apply clock pulse (see note 3).
3. Clock pulse characteristics: $V_{\text{gen}} = 3.5 \text{ V}$, $t_1 = 10 \text{ ns}$, $t_p = 20 \text{ ns}$, and $\text{PRR} = 1 \text{ MHz}$. When testing f_{max} , vary PRR.
4. Input pulse characteristics: $V_{\text{gen}} = 3.5 \text{ V}$, $t_0 = 5 \text{ ns}$.

Fig. D 9N70/5470, 7470 FLIP-FLOP SWITCHING TIMES

FAIRCHILD SERIES TTL/SSI

PARAMETER MEASUREMENT INFORMATION

SWITCHING CHARACTERISTICS (Continued)

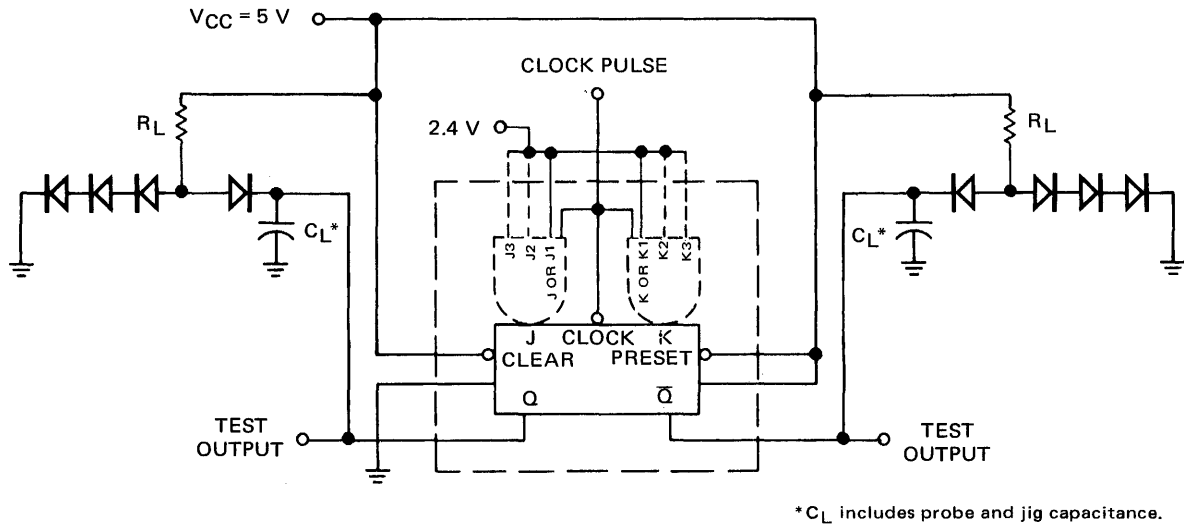

TEST CIRCUIT

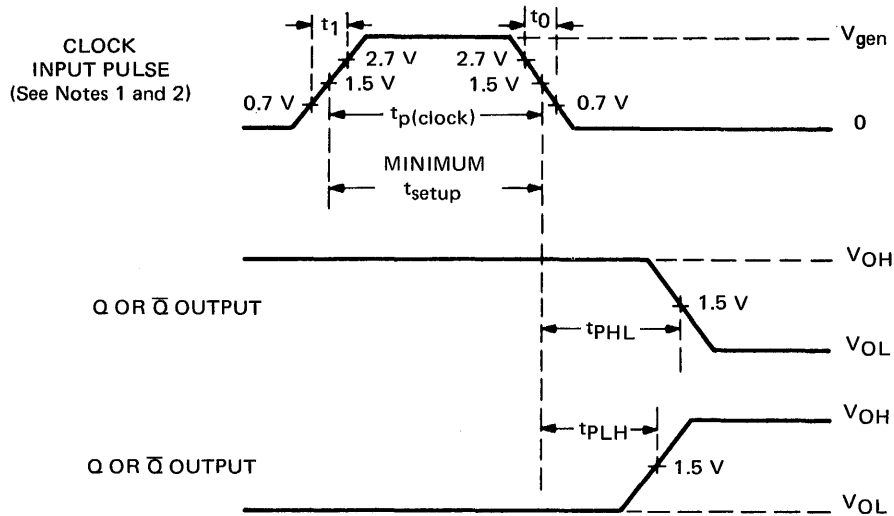

VOLTAGE WAVEFORMS

NOTES:

1. Clock, J, and K input pulse characteristics: $V_{gen} = 3.5\text{ V}$, $t_0 = 10\text{ ns}$, $t_1 = 10\text{ ns}$, $t_p = 20\text{ ns}$, and $PRR = 1\text{ MHz}$. When testing f_{max} , vary PRR.
2. For 9N72/5472, 7472, $J = J1 \cdot J2 \cdot J3$; and $K = K1 \cdot K2 \cdot K3$.
3. Gated inputs (shown with dotted lines) are for the 9N72/5472, 7472 only. The 9N73/5473, 7473; 9N107/54107, 74107 and 9N76/5476, 7476. Dual Flip-Flops have direct J and K inputs, and preset is not available on the 9N73/5473, 7473 and 9N107/54107, 74107.

Fig. E 9N72/5472, 7472; 9N73/5473, 7473; 9N76/5476, 7476; 9N107/54107, 74107 FLIP-FLOP SWITCHING TIMES

FAIRCHILD SERIES TTL/SSI

PARAMETER MEASUREMENT INFORMATION

SWITCHING CHARACTERISTICS (Continued)

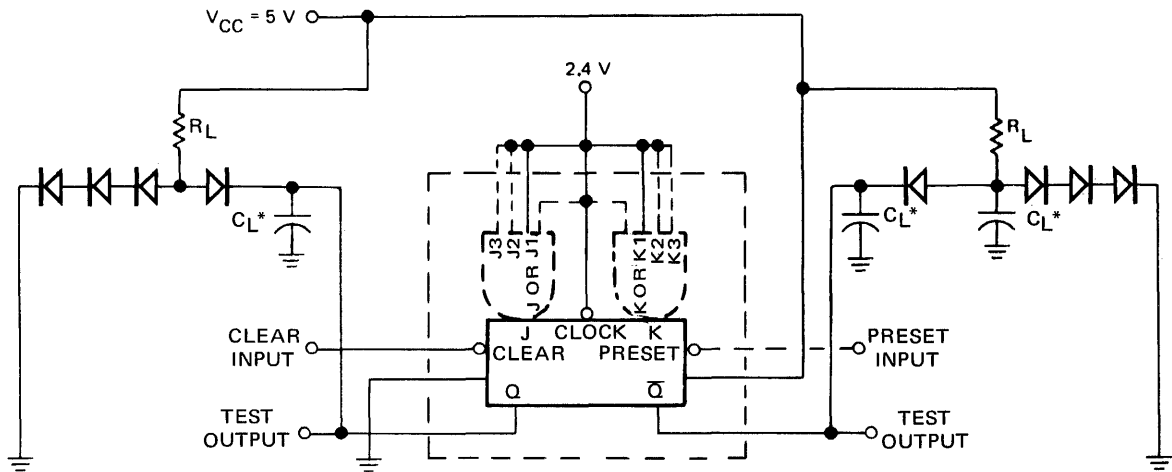

*C_L includes probe and jig capacitance

TEST CIRCUIT

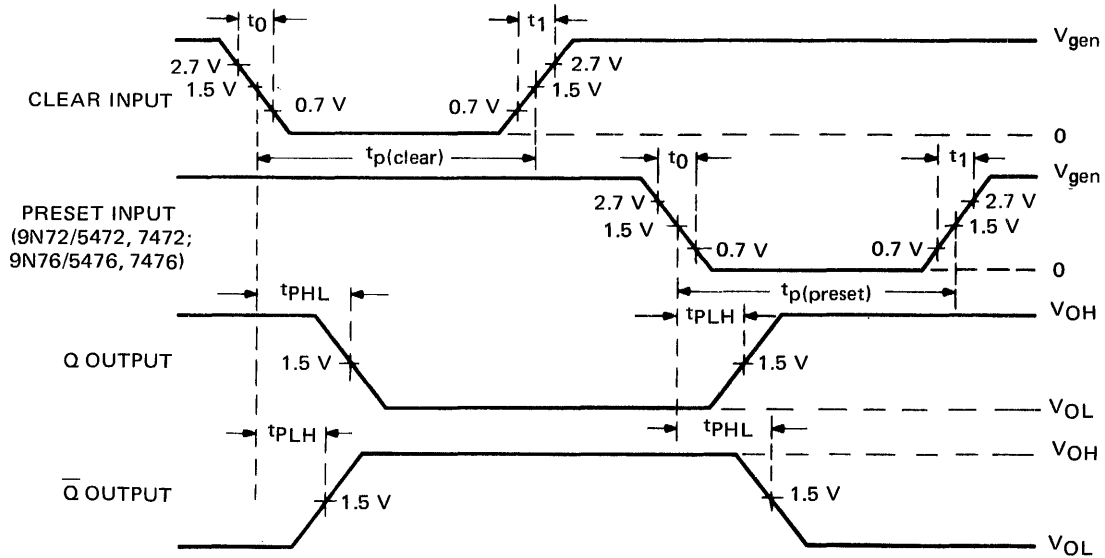

VOLTAGE WAVEFORMS

NOTES:

1. Clear or preset inputs dominate regardless of the state of clock or J-K inputs.
2. Clear or preset input pulse characteristics: $V_{CC} = 3.5\text{ V}$, $t_0 = 5\text{ ns}$, $t_1 = 10\text{ ns}$, $t_{p(\text{clear})} = t_{p(\text{preset})} = 25\text{ ns}$, $\text{PRR} = 1\text{ MHz}$, and $Z_{\text{out}} \approx 50\Omega$.
3. Gates inputs (shown with dotted lines) are for the 9N72/5472, 7472 only. The 9N73/5473, 7473; 9N76/5476, 7476 and 9N107/54107, 74107 Dual Flip-Flops have direct J and K inputs, and preset is not available on the 9N73/5473, 7473 or 9N107/54107, 74107.

Fig. F 9N72/5472, 7472; 9N73/5473, 7473; 9N76/5476, 7476; 9N107/54107, 74107 PRESET/CLEAR PROPAGATION DELAY TIMES

FAIRCHILD SERIES TTL/SSI

PARAMETER MEASUREMENT INFORMATION

SWITCHING CHARACTERISTICS (Continued)

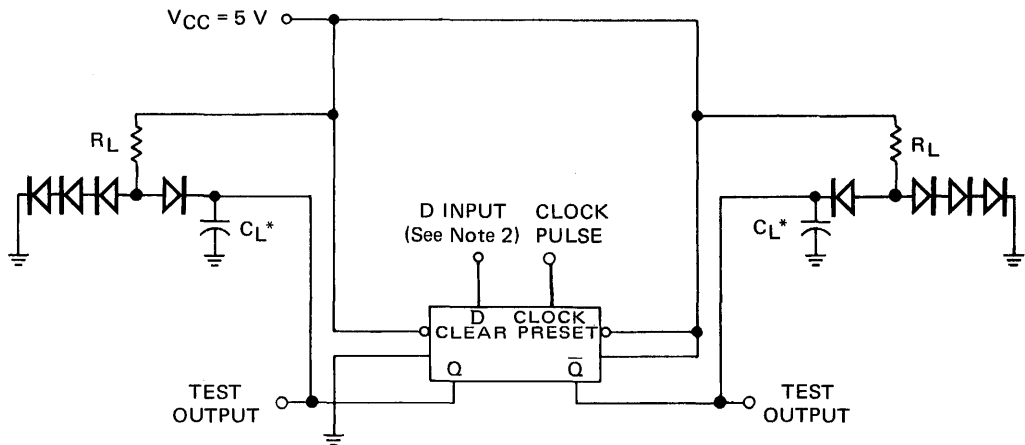

* C_L includes probe and jib capacitance

TEST CIRCUIT

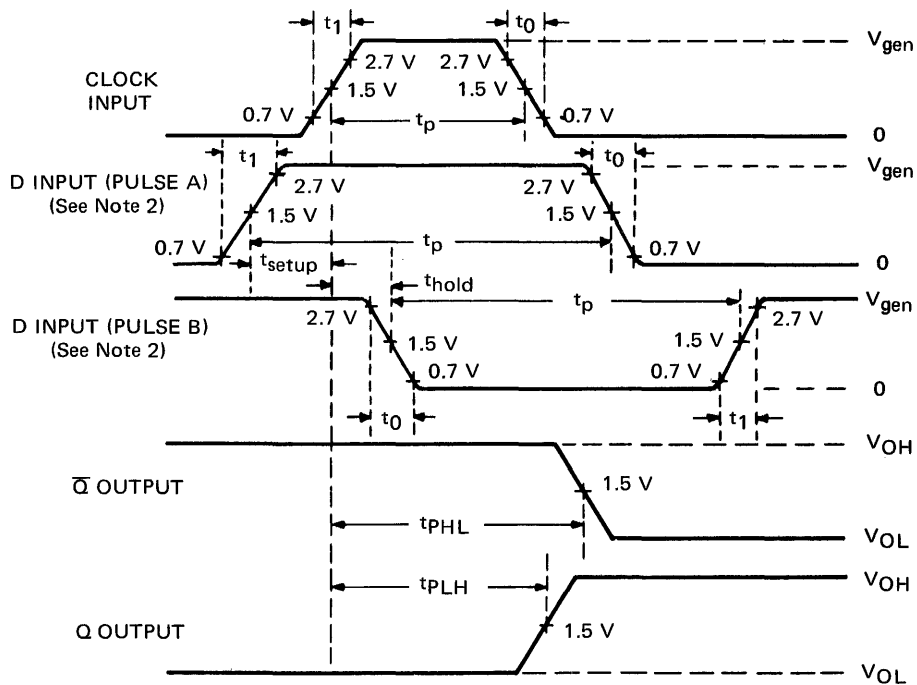

VOLTAGE WAVEFORMS

NOTES:

1. Clock input pulse has the following characteristics: $V_{gen} = 3.5\text{ V}$, $t_0 = 10\text{ ns}$, $t_1 = 10\text{ ns}$, $t_p = 30\text{ ns}$, and $PRR = 1\text{ MHz}$. When testing f_{max} , vary PRR.
2. D input (pulse A) has the following characteristics: $V_{gen} = 3.5\text{ V}$, $t_0 = 10\text{ ns}$, $t_1 = 10\text{ ns}$, $t_{setup} = 20\text{ ns}$, $t_p = 60\text{ ns}$, and PRR is 50% of the clock PRR. D input (pulse B) has the following characteristics: $V_{gen} = 3.5\text{ V}$, $t_0 = 10\text{ ns}$, $t_1 = 10\text{ ns}$, $t_{hold} = 5\text{ ns}$, $t_p = 60\text{ ns}$, and PRR is 50% of the clock PRR.

Fig. G 9N74/5474, 7474 FLIP-FLOP SWITCHING TIMES

FAIRCHILD SERIES TTL/SSI

PARAMETER MEASUREMENT INFORMATION

SWITCHING CHARACTERISTICS (Continued)

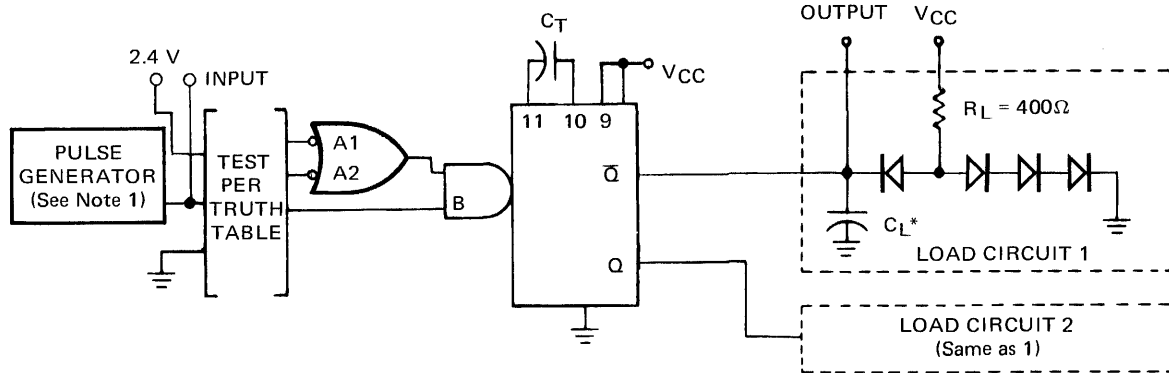

* C_L includes probe and jig capacitance

TEST CIRCUIT

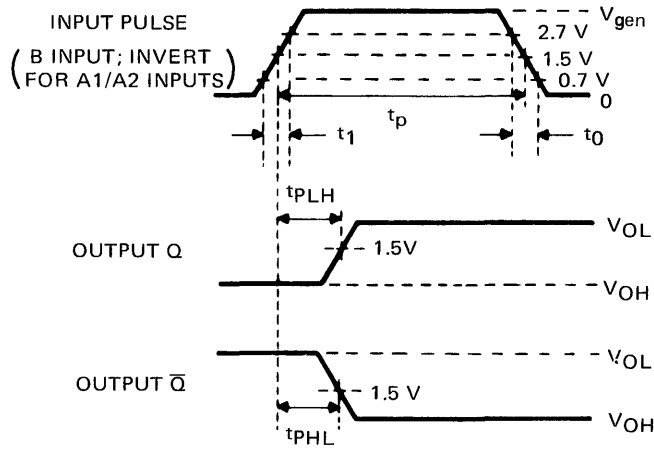

VOLTAGE WAVEFORMS

NOTE:

1. The pulse generator has the following characteristics: $V_{gen} = 3.5\text{ V}$, $t_0 = 5\text{ ns}$, $t_1 = 10\text{ ns}$, $t_p \geq 50\text{ ns}$, $PRR = 1\text{ MHz}$, and $Z_{out} \approx 50\Omega$.

Fig. H 9N121/54121, 74121 SWITCHING TIMES

FAIRCHILD SERIES TTL/SSI

PARAMETER MEASUREMENT INFORMATION

SWITCHING CHARACTERISTICS (Continued)

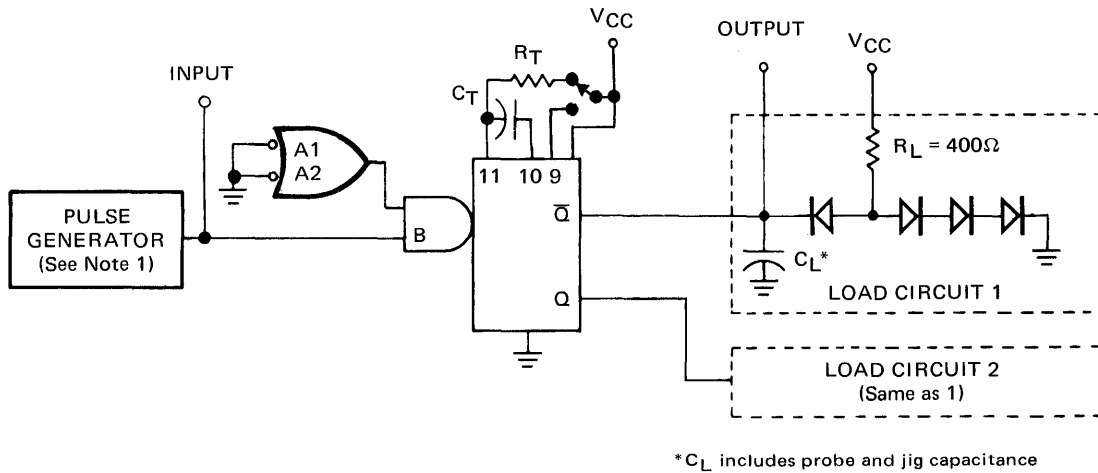

TEST CIRCUIT

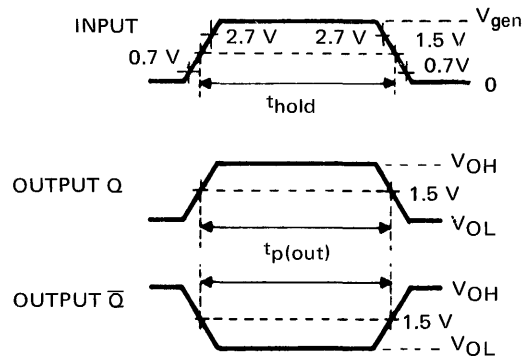

VOLTAGE WAVEFORMS

NOTE:

1. The pulse generator has the following characteristics: $V_{gen} = 3.5 \text{ V}$, $t_0 = 5 \text{ ns}$, $t_1 = 10 \text{ ns}$, $t_p = 50 \text{ ns}$, $PRR = 1 \text{ MHz}$, and $Z_{out} \approx 50 \Omega$.

Fig. 1 $t_{p(out)}$ (internal/minimum), t_{hold}

FAIRCHILD SERIES TTL/SSI

PARAMETER MEASUREMENT INFORMATION

SWITCHING CHARACTERISTICS (Continued)

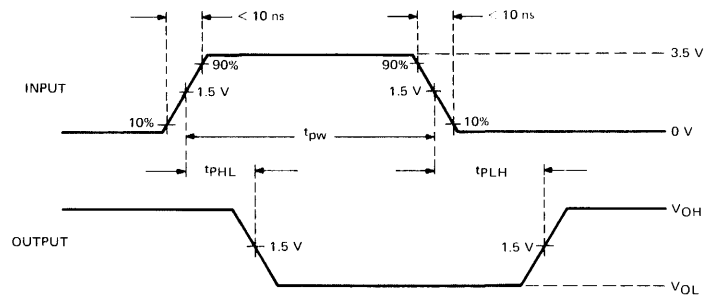
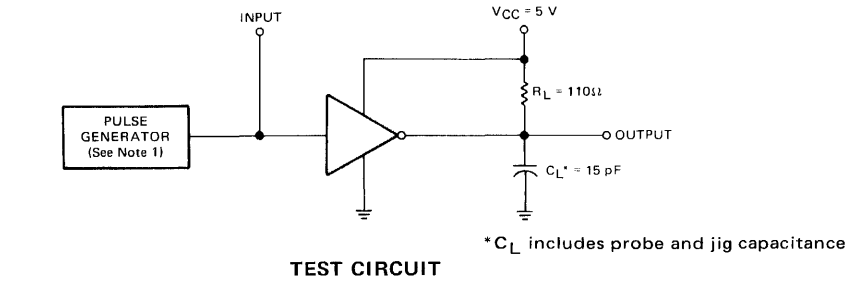

NOTE:

- The generator has the following characteristics: $t_{pw} = 0.5 \mu s$, $PRR = 1 \text{ MHz}$, $Z_{out} \approx 50\Omega$.

Fig. J PROPAGATION DELAY TIMES

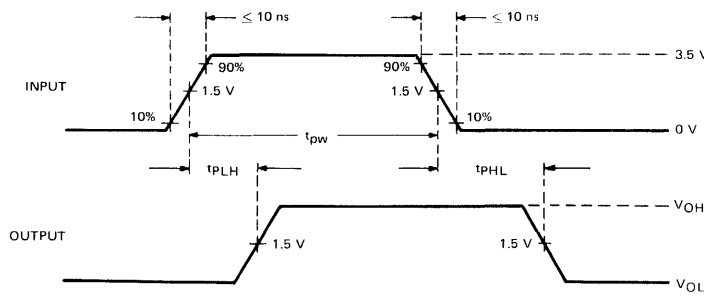
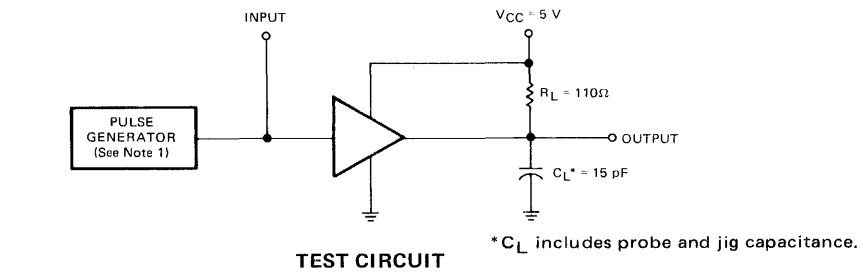

NOTE:

- The generator has the following characteristics: $t_{pw} = 0.5 \mu s$, $PRR = 1 \text{ MHz}$, $Z_{out} \approx 50\Omega$.

Fig. K PROPAGATION DELAY TIMES

FAIRCHILD SERIES TTL/SSI

PARAMETER MEASUREMENT INFORMATION

SWITCHING CHARACTERISTICS (Continued)

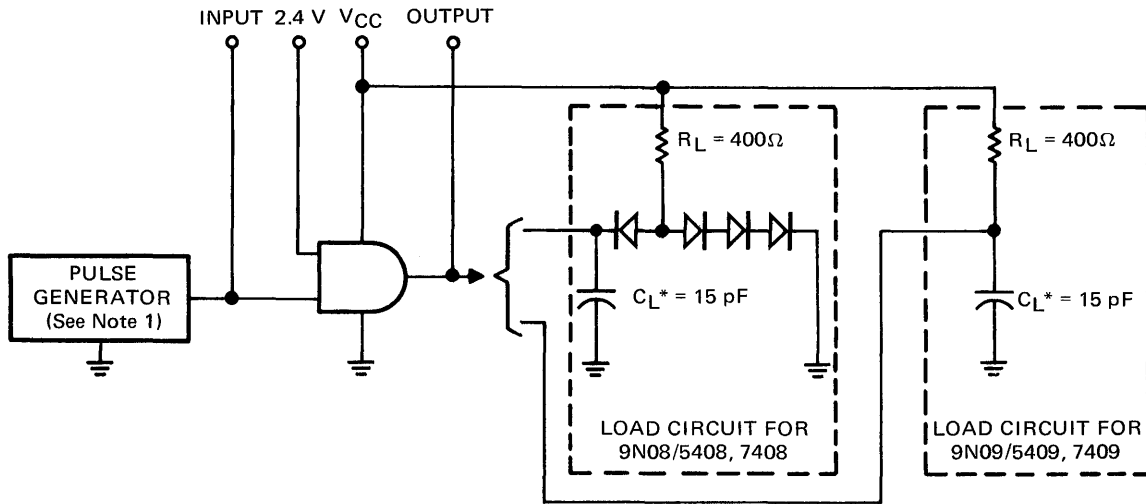

* C_L includes probe and jig capacitance.

TEST CIRCUIT

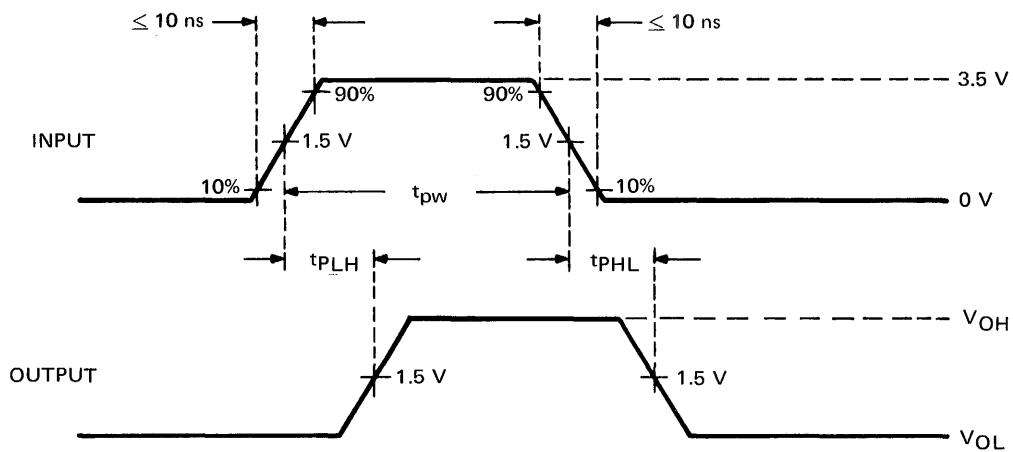

VOLTAGE WAVEFORMS

NOTE:

- The generator has the following characteristics: $t_{pw} = 0.5\ \mu\text{s}$, $\text{PRR} = 1\ \text{MHz}$, $Z_{out} \approx 50\ \Omega$.

Fig. L PROPAGATION DELAY TIMES

FAIRCHILD SERIES TTL/SSI

PARAMETER MEASUREMENT INFORMATION

SWITCHING CHARACTERISTICS (Continued)

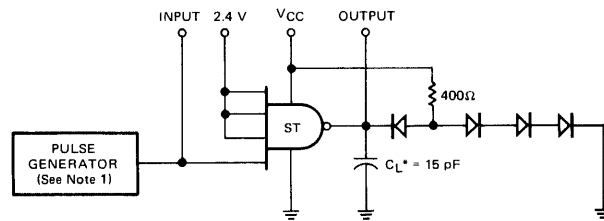

* C_L includes probe and jig capacitance

TEST CIRCUIT

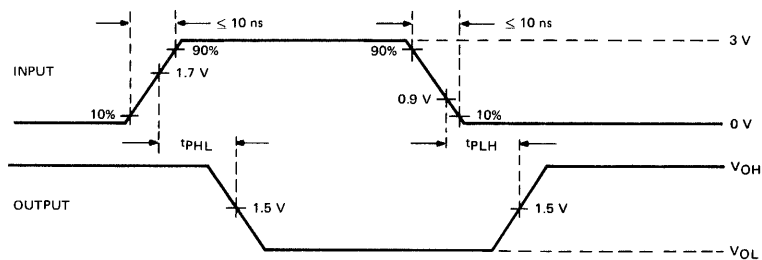

VOLTAGE WAVEFORMS

NOTE:

- The pulse generator has the following characteristics: $t_{pw} = 0.5 \mu s$, $PRR = 1 \text{ MHz}$, $Z_{out} \approx 50 \Omega$.

Fig. M PROPAGATION DELAY TIMES

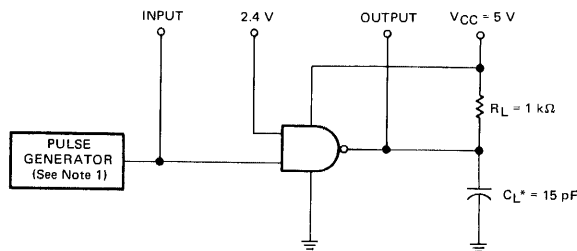

* C_L includes probe and jig capacitance.

TEST CIRCUIT

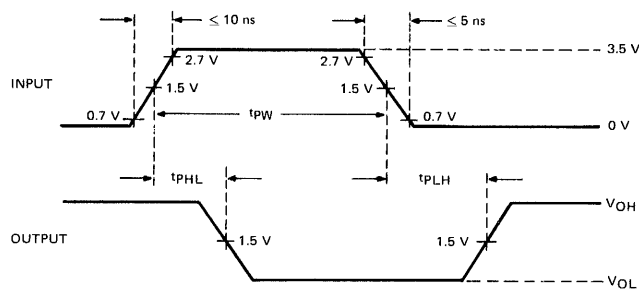

VOLTAGE WAVEFORMS

NOTE:

- The generator has the following characteristics: $t_{pw} = 0.5 \mu s$, $PRR = 1 \text{ MHz}$, $Z_{out} \approx 50 \Omega$.

Fig. N PROPAGATION DELAY TIMES

FAIRCHILD SERIES TTL/SSI

PARAMETER MEASUREMENT INFORMATION

SWITCHING CHARACTERISTICS (Continued)

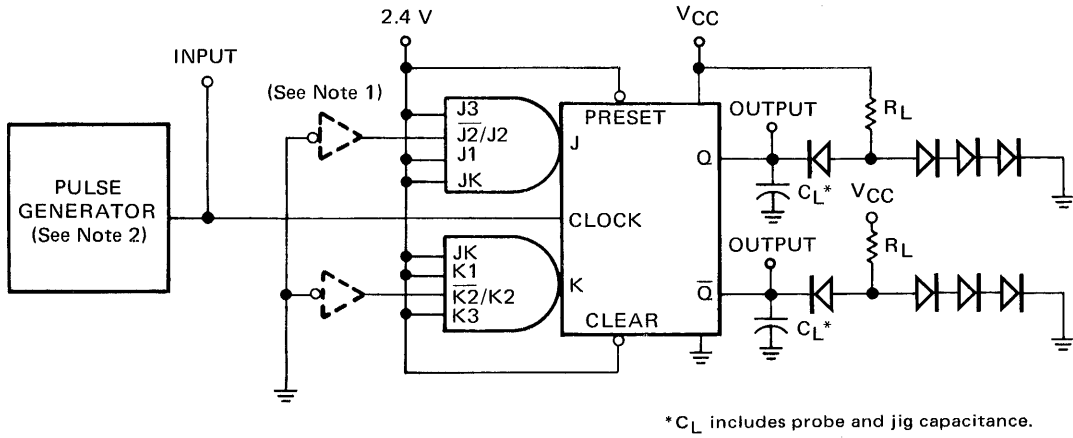

TEST CIRCUIT

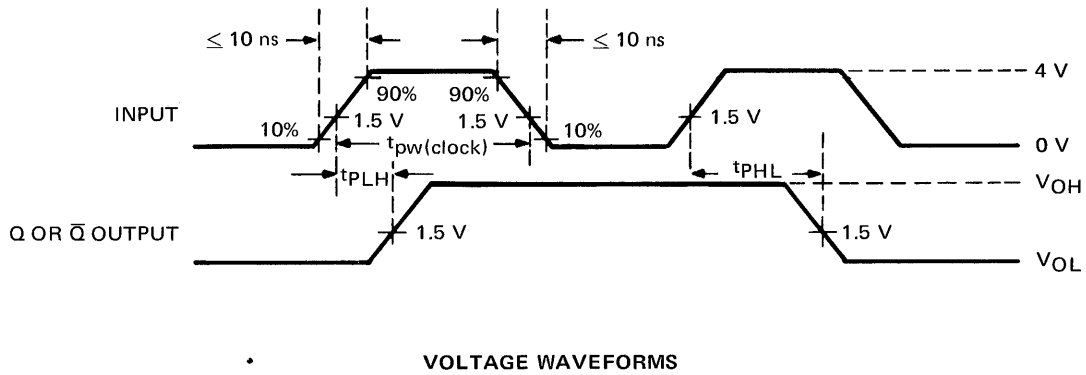

NOTES:

1. Test circuit shown is for the 9N105/54105, 74105. When testing 9N104/54104, 74104, the J2 and K2 inputs are connected in parallel with the other J and K inputs.
2. The pulse generator has the following characteristics: $t_{pw(clock)} = 250 \text{ ns}$, $PRR = 1 \text{ MHz}$, $Z_{out} \approx 50 \Omega$.

Fig. O PROPAGATION DELAY TIMES

FAIRCHILD SERIES TTL/SSI

PARAMETER MEASUREMENT INFORMATION

SWITCHING CHARACTERISTICS (Continued)

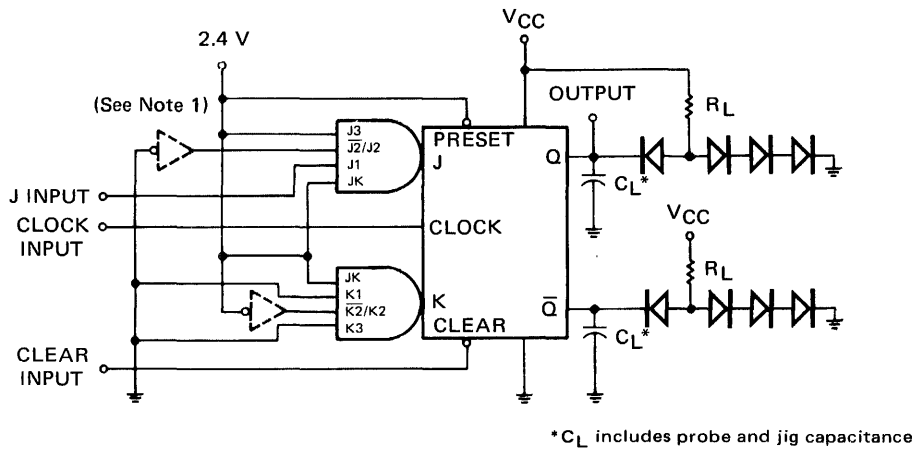

TEST CIRCUIT

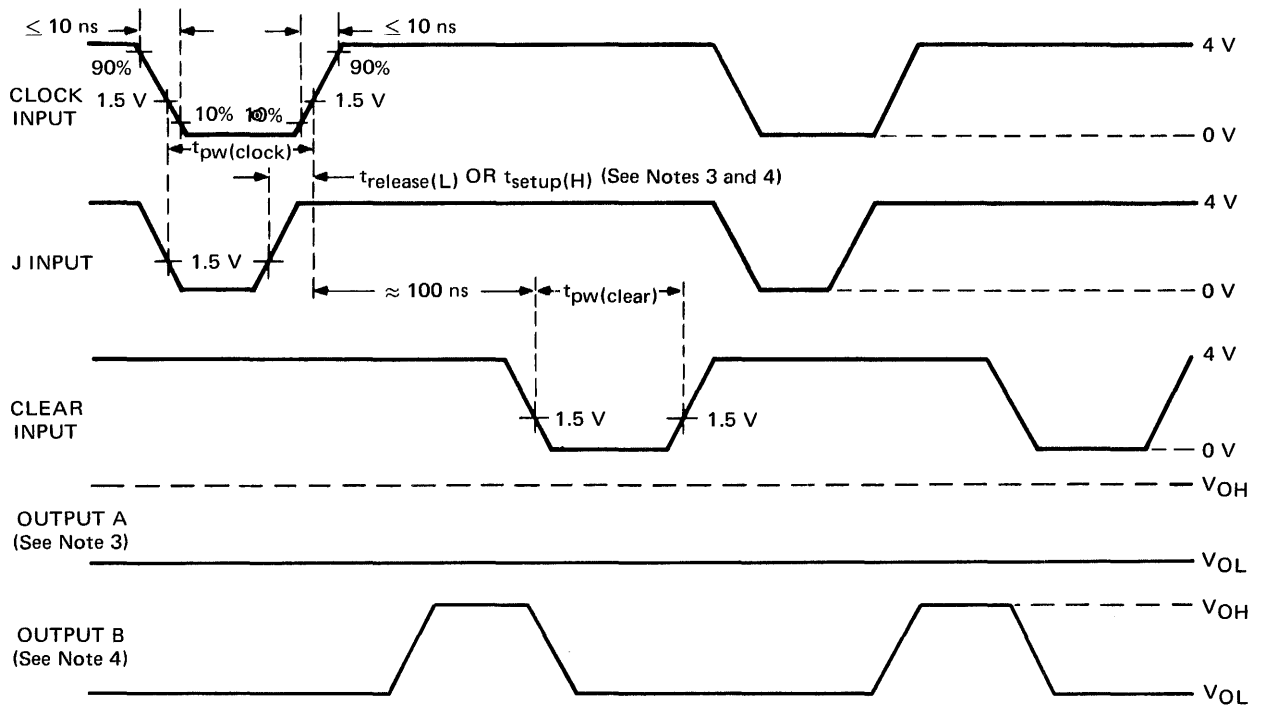

NOTES:

1. Test circuit shown is for the 9N105/54105, 74105. When testing 9N104/54104, 74104, the J2 input is connected in parallel with the other J inputs and K2 is grounded.
2. The input pulses have the following characteristics: PRR = 1 MHz, $t_{pw}(\text{clock}) = 100 \text{ ns}$, and $t_w(\text{clear}) = 100 \text{ ns}$. For duration of the J-input pulse, see Notes 3 and 4.
3. Output A is valid for: 9N104/54104, 74104, $t_{\text{release}}(\text{L}) \leq 10 \text{ ns}$; 9N105/54105, 74105, $t_{\text{release}}(\text{L}) \leq 1 \text{ ns}$.
4. Output B is valid for: 9N104/54104, 74104, $t_{\text{setup}}(\text{H}) \geq 35 \text{ ns}$; 9N105/54105, 74105, $t_{\text{setup}}(\text{H}) \geq 10 \text{ ns}$.

Fig. P INPUT SETUP/RELEASE TIMES

FAIRCHILD SERIES TTL/SSI

PARAMETER MEASUREMENT INFORMATION

SWITCHING CHARACTERISTICS (Continued)

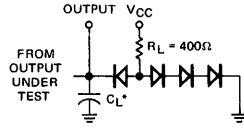

* C_L includes probe and jig capacitance.

LOAD FOR OUTPUT UNDER TEST

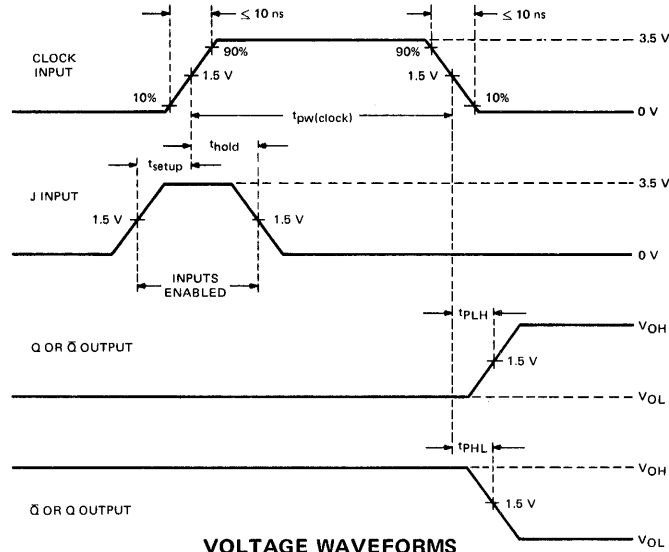

VOLTAGE WAVEFORMS

NOTE:

- Both input pulses are supplied by generators with the following characteristics: PRR = 1 MHz, $Z_{out} \approx 50\Omega$. Clock duty cycle = 50%.

Fig. Q

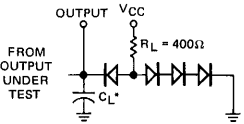

* C_L includes probe and jig capacitance.

LOAD FOR OUTPUT UNDER TEST

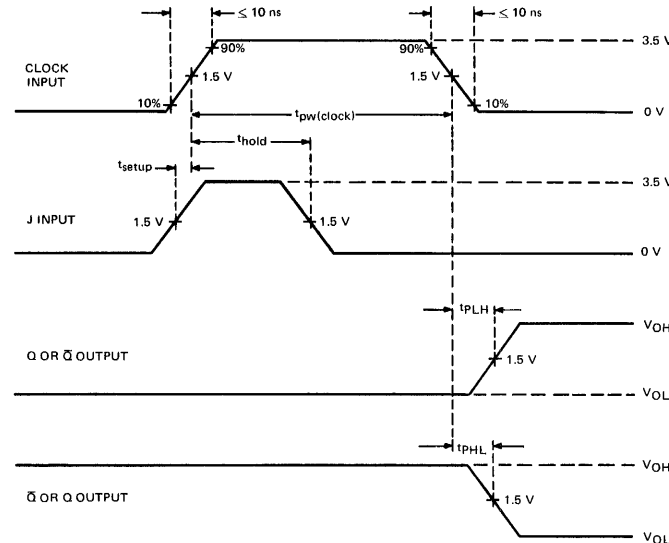

VOLTAGE WAVEFORMS

NOTE:

- Both input pulses are supplied by generators with the following characteristics: PRR = 1 MHz, $Z_{out} \approx 50\Omega$, clock duty cycle = 50%.

Fig. R

FAIRCHILD SERIES TTL/SSI

PARAMETER MEASUREMENT INFORMATION

SWITCHING CHARACTERISTICS (Continued)

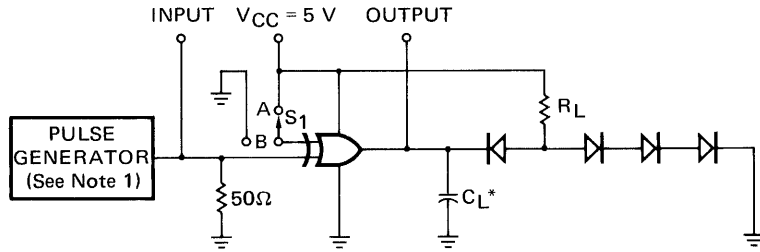

* C_L includes probe and jig capacitance

TEST CIRCUIT

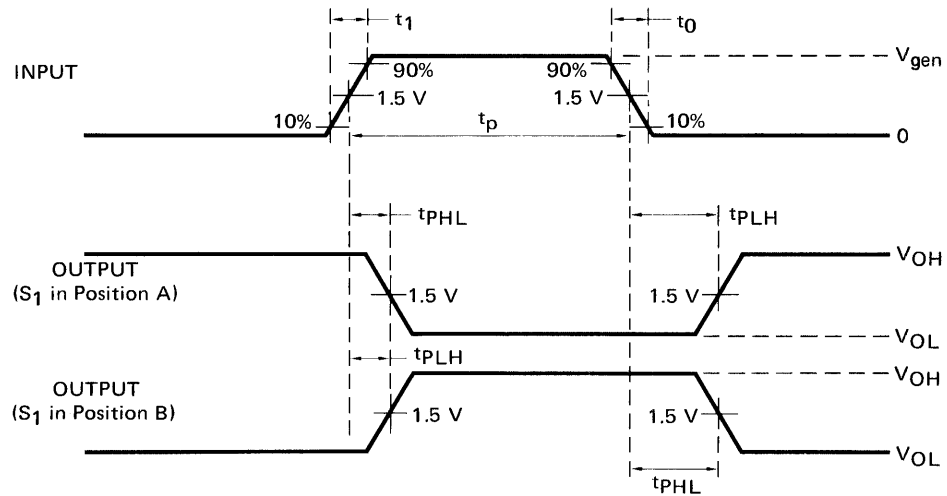

VOLTAGE WAVEFORMS

NOTES:

1. The generator has the following characteristics: $V_{gen} = 3.0\text{ V}$, $t_0 = t_1 \leq 15\text{ ns}$, $t_p = 0.5\text{ }\mu\text{s}$, $\text{PRR} = 1\text{ MHz}$, $Z_{out} \approx 50\text{ }\Omega$.
2. Propagation Delay = $\frac{t_{PHL} + t_{PLH}}{2}$
3. Each gate tested separately.

Fig. S

FAIRCHILD SERIES TTL/SSI

PARAMETER MEASUREMENT INFORMATION

SWITCHING CHARACTERISTICS

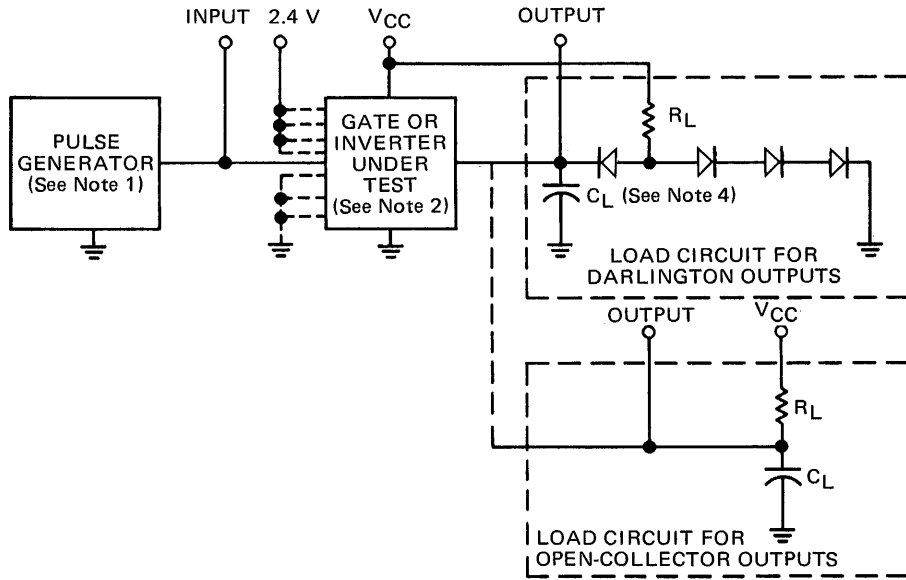

TEST CIRCUIT

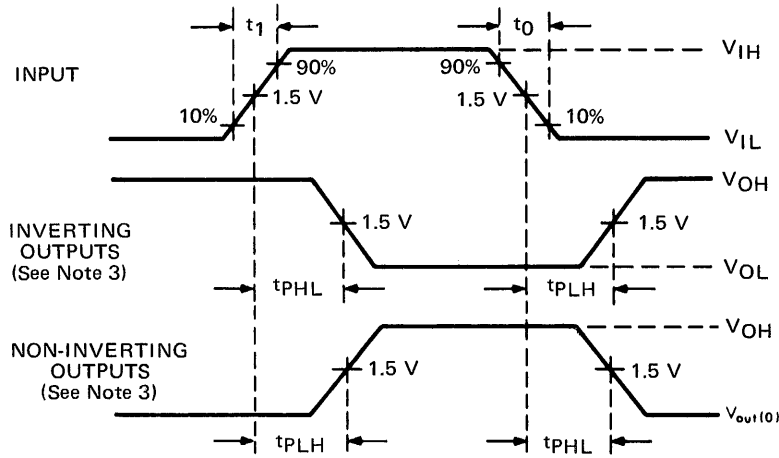

VOLTAGE WAVEFORMS

NOTES:

- 1 The pulse generator has the following characteristics: $V_{IH} = 3\text{ V}$, $V_{IL} = 0\text{ V}$, $t_1 = t_0 = 7\text{ ns}$, $\text{PRR} = 1\text{ MHz}$, duty cycle = 50%, and $Z_{OUT} \approx 50\Omega$.
- 2 Input conditions are established for each gate as follows:
 - a. Input pulse is applied to one input and 2.4 V is applied to all unused inputs of the 9H00/54H00, 74H00; 9H01/54H01, 74H01; 9H04/54H04, 74H04; 9H05/54H05, 74H05; 9H10/54H10, 74H10; 9H11/54H11, 74H11; 9H20/54H20, 74H20; 9H21/54H21, 74H21; 9H22/54H22, 74H22; 9H30/54H30, 74H30; or 9H40/54H40, 74H40 gate.
 - b. Input pulse is applied to one input of one AND section, and 2.4 V is applied to all unused inputs of that AND section of the 9H50/54H50, 74H50; 9H51/54H51, 74H51; 9H52/54H52, 74H52; 9H53/54H53, 74H53; 9H54/54H54, 74H54; or 9H55/54H55, 74H55 gate. All inputs of all unused AND sections are grounded.
- 3 All gates are inverting except the 9H11/54H11, 74H11; 9H21/54H21, 74H21; and 9H52/54H52, 74H52 only.
- 4 C_L includes probe and jig capacitance.

Fig. T GATE PROPAGATION DELAY TIMES

FAIRCHILD SERIES TTL/SSI

PARAMETER MEASUREMENT INFORMATION

SWITCHING CHARACTERISTICS (Continued)

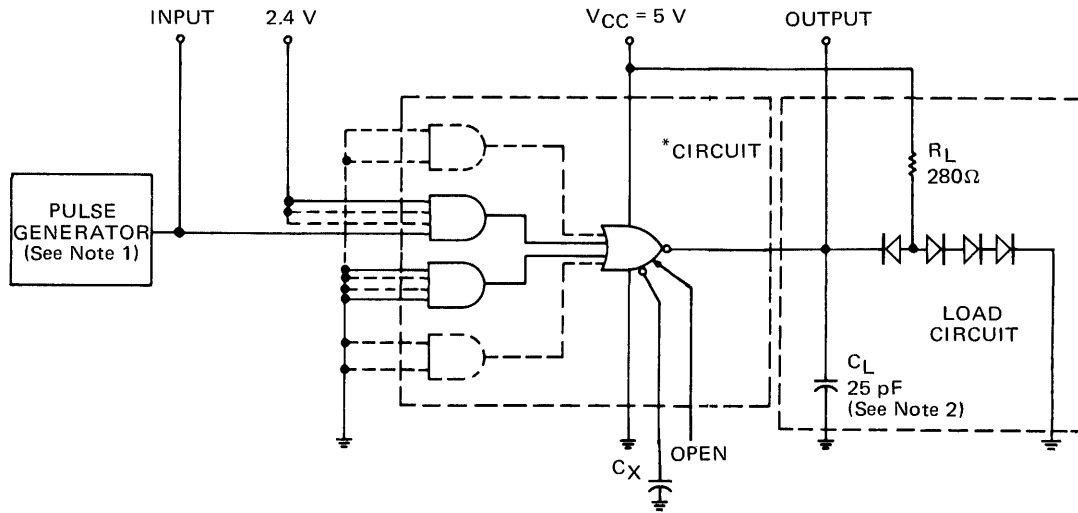

TEST CIRCUIT

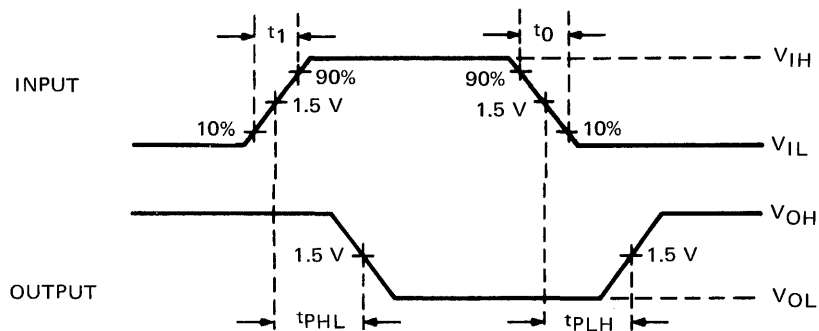

VOLTAGE WAVEFORMS

NOTES:

- 1 The generator has the following characteristics: $V_{IH} = 3\text{ V}$, $V_{IL} = 0\text{ V}$, $t_0 = t_1 = 7\text{ ns}$, duty cycle = 50%, PRR = 1 MHz $Z_{OUT} \approx 50\Omega$.
- 2 C_L includes probe and jig capacitance
- 3 C_X includes jig capacitance.

*9H50/54H50, 74H50; 9H53/54H53, 74H53; 9H55/54H55, 74H55

Fig. U PROPAGATION DELAY TIMES

FAIRCHILD SERIES TTL/SSI

PARAMETER MEASUREMENT INFORMATION

SWITCHING CHARACTERISTICS (Continued)

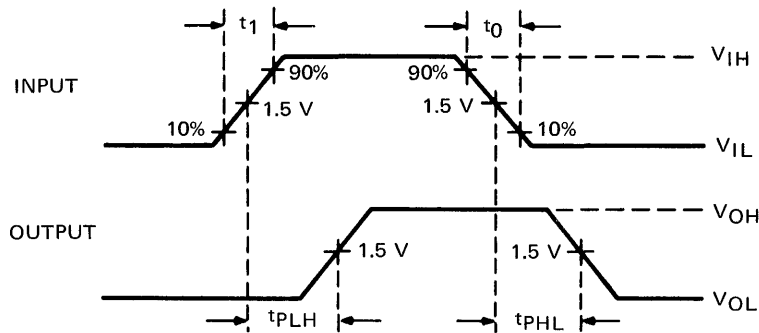
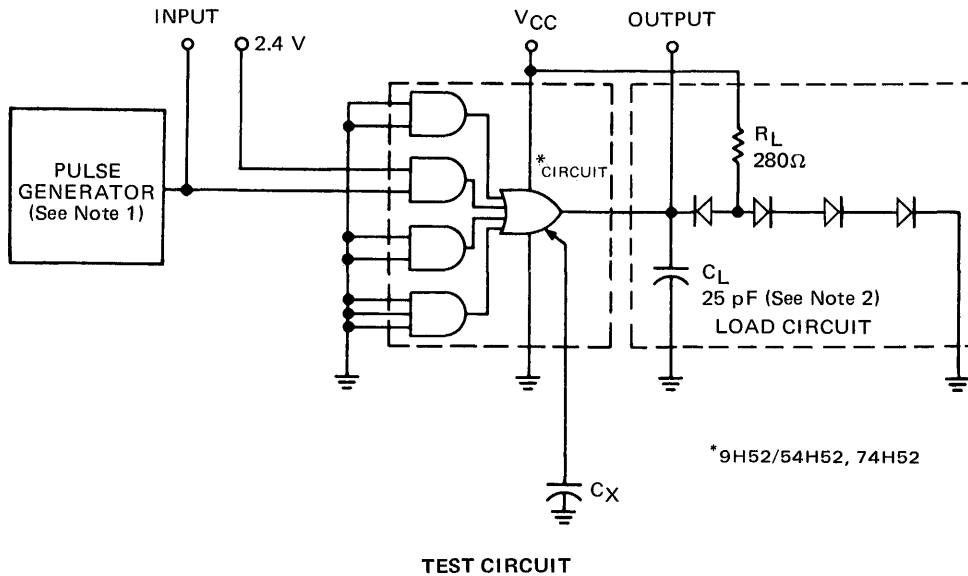

NOTES:

- 1 The generator has the following characteristics: $V_{IH} = 3\text{ V}$, $V_{IL} = 0\text{ V}$, $t_0 = t_1 = 7\text{ ns}$, duty cycle = 50%, PRR = 1 MHz, $V_{OUT} \approx 50\Omega$.
- 2 C_L includes probe and jig capacitance.
- 3 C_X includes jig capacitance.

Fig. V PROPAGATION DELAY TIMES

FAIRCHILD SERIES TTL/SSI

PARAMETER MEASUREMENT INFORMATION

SWITCHING CHARACTERISTICS (Continued)

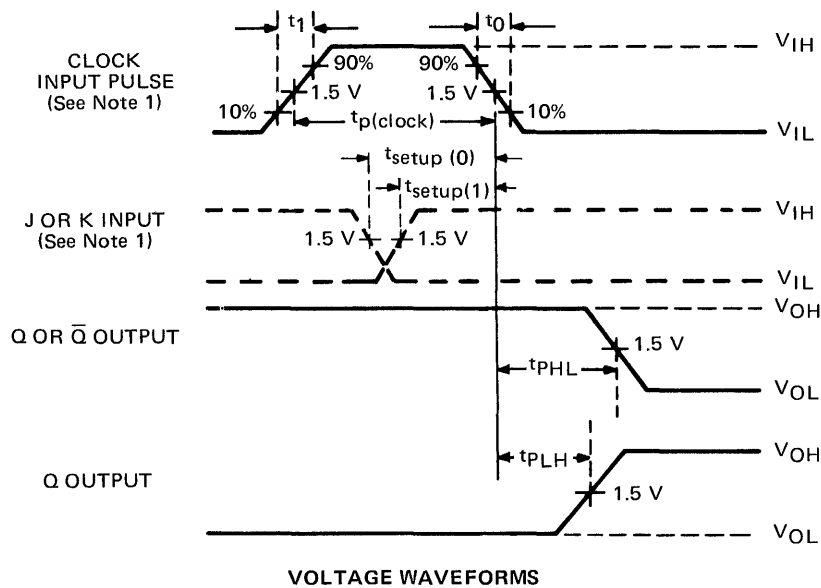
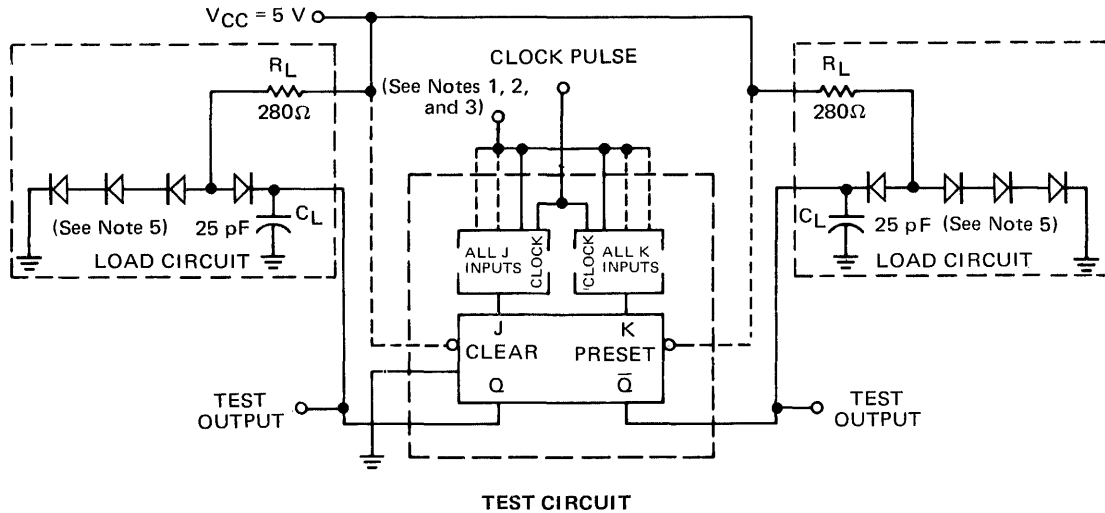

NOTES:

- 1 When testing t_{pHL} and t_{pLH} (all types), the clock input pulse characteristics are: $V_{IH} = 3\text{ V}$, $V_{IL} = 0\text{ V}$, $t_1 = t_0 = 7\text{ ns}$, $t_{p(\text{clock})} = 20\text{ ns}$, and $\text{PRR} = 1\text{ MHz}$. When testing 9H71/54H71, 74H71; 9H72/54H72, 74H72; 9H73/54H73, 74H73; 9H76/54H76, 74H76 and 9H78/54H78, 74H78 all J and K inputs are at 2.4 V. When testing 9H101/54H101, 74H101; 9H102/54H102, 74H102; 9H103/54H103, 74H103; 9H106/54H106, 74H106 and 9H108/54H108, 74H108 conditions are established to ensure that minimum setup times are verified.
- 2 When testing f_{clock} of 9H71/54H71, 74H71; 9H72/54H72, 74H72; 9H73/54H73, 74H73; 9H76/54H76, 74H76 and 9H78/54H78, 74H78, the clock input characteristics are: $V_{IH} = 3\text{ V}$, $V_{IL} = 0\text{ V}$, $t_1 = t_0 = 3\text{ ns}$, $t_{p(\text{clock})} = 12\text{ ns}$, and $\text{PRR} = 25\text{ MHz}$. All J and K inputs are at 2.4 V.
- 3 When testing f_{clock} of 9H101/54H101, 74H101; 9H102/54H102, 74H102; 9H103/54H103, 74H103; 9H106/54H106, 74H106 and 9H108/54H108, 74H108, the clock input characteristics are: $V_{IH} = 3\text{ V}$, $V_{IL} = 0\text{ V}$, $t_1 = t_0 = 3\text{ ns}$, $t_{p(\text{clock})} = 10\text{ ns}$ and $\text{PRR} = 40\text{ MHz}$. All J and K inputs are at 2.4 V.
- 4 See applicable circuit type for actual J and K input configuration and presence of preset or clear functions.
- 5 C_L includes probe and jig capacitance.

Fig. W FLIP-FLOP PROPAGATION DELAY TIMES

FAIRCHILD SERIES TTL/SSI

PARAMETER MEASUREMENT INFORMATION

SWITCHING CHARACTERISTICS (Continued)

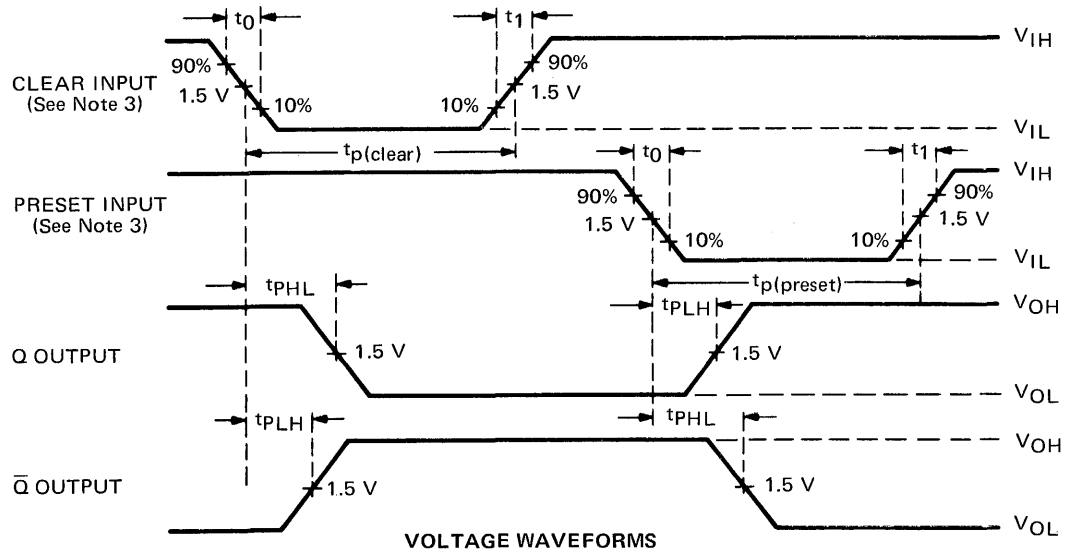
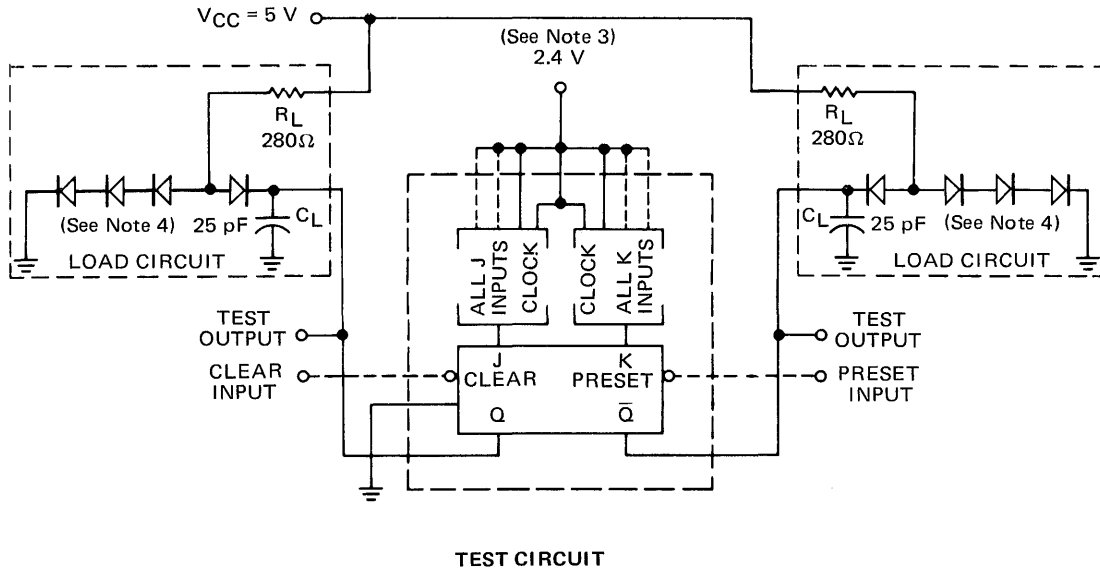

NOTES:

- 1 Clear or Preset inputs dominate regardless of the state of Clock or J-K inputs.
- 2 Clear or Preset input pulse characteristics: $V_{IH} = 3\text{ V}$, $V_{IL} = 0\text{ V}$, $t_1 = t_0 = 7\text{ ns}$, $t_{p(\text{clear})} = t_{p(\text{preset})} = 16\text{ ns}$, and $\text{PRR} = 1\text{ MHz}$.
- 3 See applicable circuit type for actual J and K input configuration and presence of Preset or Clear functions.
- 4 C_L includes probe and jig capacitance.

Fig. X FLIP-FLOP PRESET/CLEAR PROPAGATION DELAY TIMES

6

FAIRCHILD SERIES TTL/SSI

PARAMETER MEASUREMENT INFORMATION

SWITCHING CHARACTERISTICS (Continued)

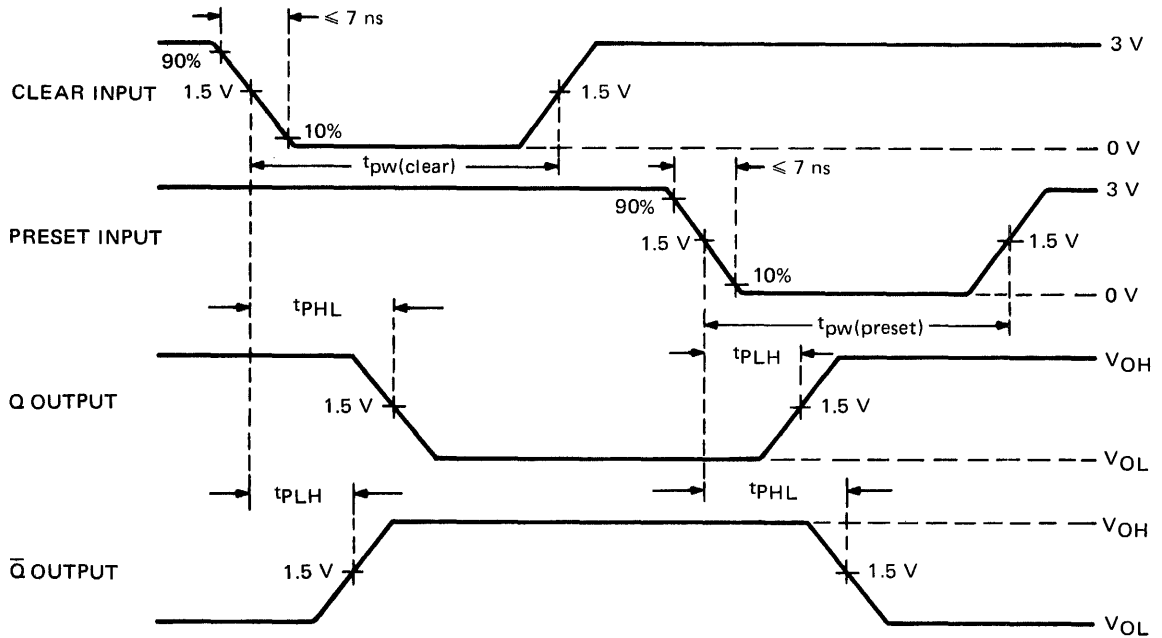
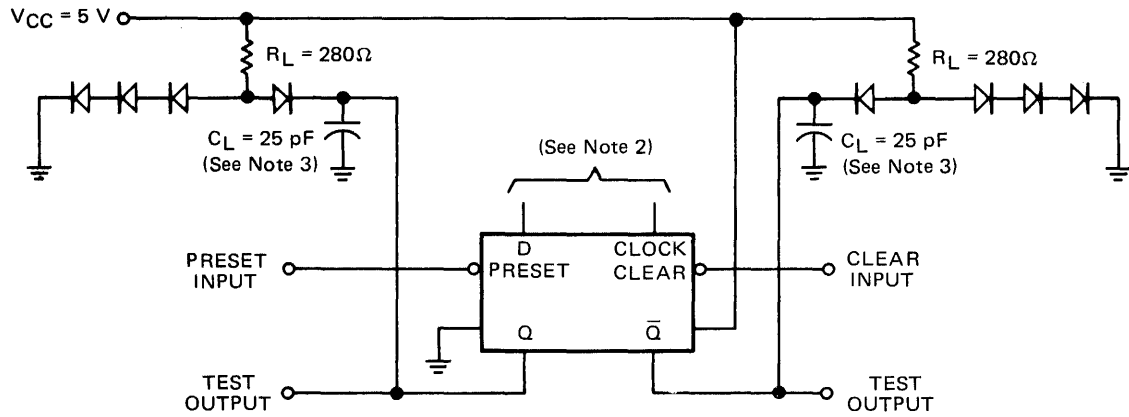

NOTES:

- 1 Clear or Preset input pulse characteristics: $t_{pw}(\text{clear}) = t_{pw}(\text{preset}) = 25 \text{ ns}$, $\text{PRR} = 1 \text{ MHz}$.
- 2 Clear and Preset inputs dominate regardless of the state of Clock or D inputs.
- 3 C_L includes probe and jig capacitance.

Fig. Y ASYNCHRONOUS INPUTS SWITCHING CHARACTERISTICS

FAIRCHILD SERIES TTL/SSI

PARAMETER MEASUREMENT INFORMATION

SWITCHING CHARACTERISTICS (Continued)

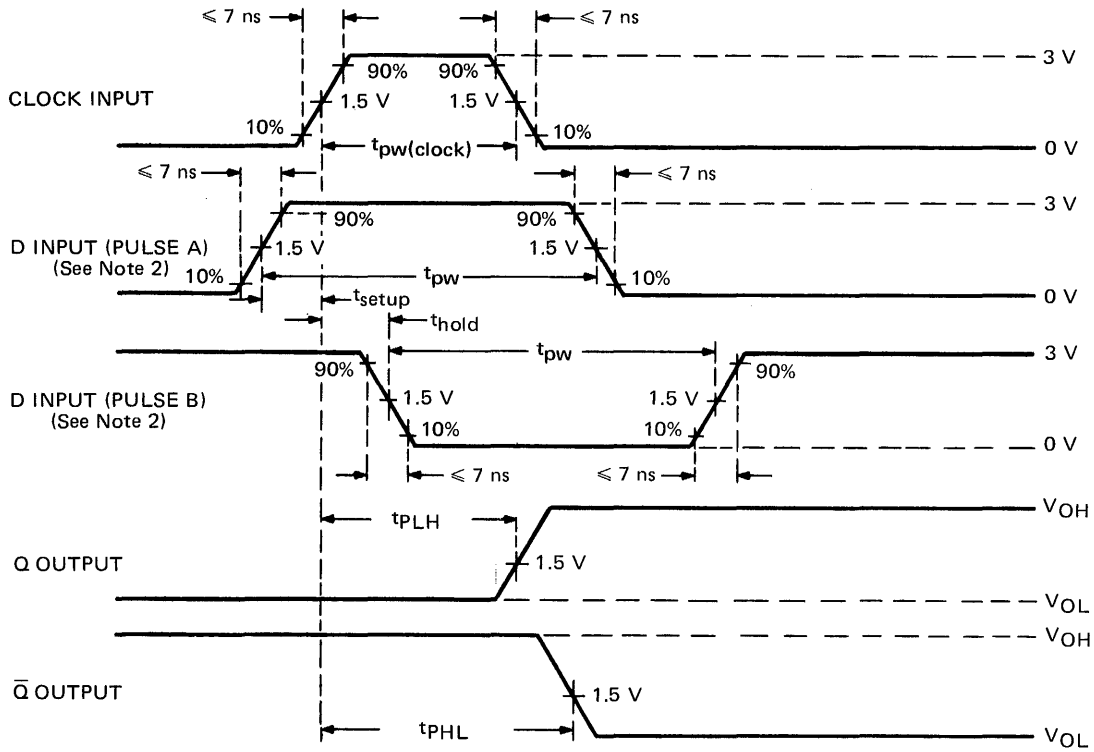
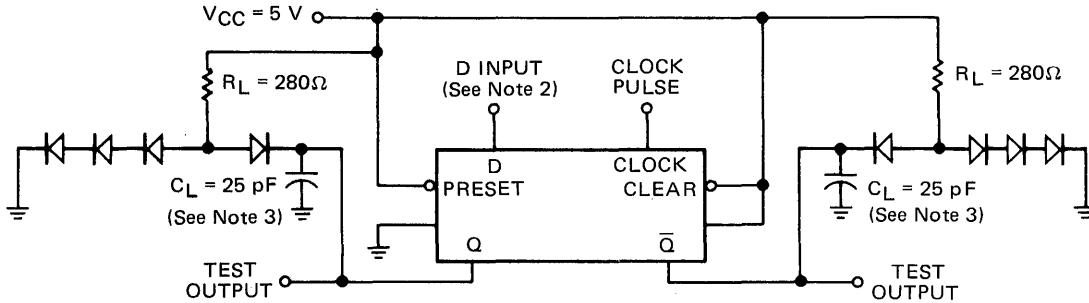

NOTES:

- 1 Clock input pulse has the following characteristics: $t_{pw}(\text{clock}) = 20 \text{ ns}$ and $\text{PRR} = 1 \text{ MHz}$. When testing f_{clock} , vary PRR.
- 2 D input (pulse A) has the following characteristics: $t_{\text{setup}} = 10 \text{ ns}$, $t_{pw} = 60 \text{ ns}$, and PRR is 50% of the clock PRR. D input (pulse B) has the following characteristics: $t_{\text{hold}} = 0 \text{ ns}$, $t_{pw} = 60 \text{ ns}$, and PRR is 50% of the clock PRR.
- 3 C_L includes probe and jig capacitance.

Fig. Z SWITCHING CHARACTERISTICS, CLOCK AND SYNCHRONOUS INPUTS (HIGH-LEVEL DATA)

FAIRCHILD SERIES TTL/SSI

PARAMETER MEASUREMENT INFORMATION

SWITCHING CHARACTERISTICS (Continued)

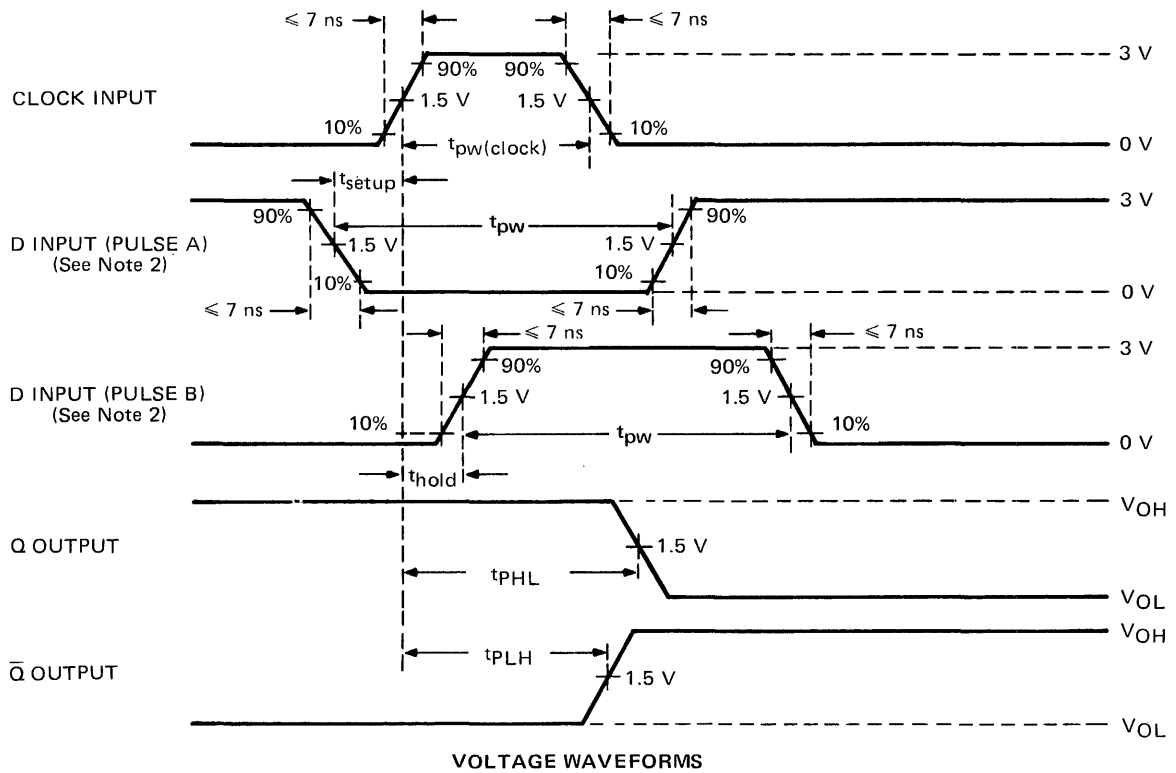
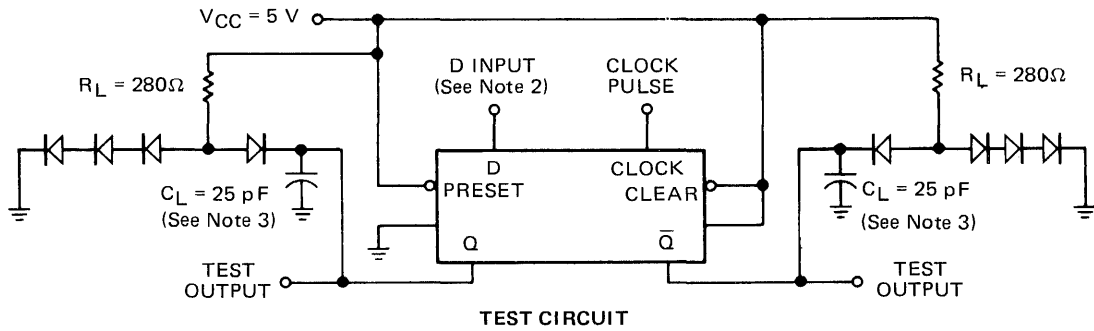

NOTES:

- 1 Clock input pulse has the following characteristics: $t_{pw} = 20 \text{ ns}$ and $\text{PRR} = 1 \text{ MHz}$. When testing f_{clock} , vary PRR.
- 2 D input (pulse A) has the following characteristics: $t_{\text{setup}} = 15 \text{ ns}$, $t_{pw} = 60 \text{ ns}$, and PRR is 50% of the clock PRR. D input (pulse B) has the following characteristics: $t_{\text{hold}} = 0 \text{ ns}$, $t_{pw} = 60 \text{ ns}$, and PRR is 50% of the clock PRR.
- 3 C_L includes probe and jig capacitance.

Fig. AA SWITCHING CHARACTERISTICS, CLOCK AND SYNCHRONOUS INPUTS (LOW-LEVEL DATA)

FAIRCHILD SERIES TTL/SSI

PARAMETER MEASUREMENT INFORMATION

SWITCHING TIME DATA TEST CIRCUITS

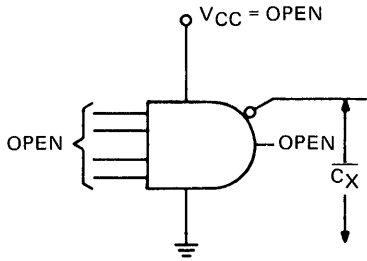

1. Each output is tested separately.

Fig. BB

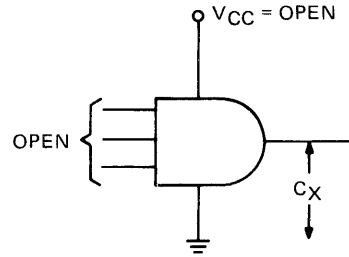

1. Each output is tested separately.

Fig. CC

SWITCHING CHARACTERISTICS TEST CIRCUIT AND WAVEFORM FOR 9S00, 9S04, 9S20, 9S40 AND 9S140

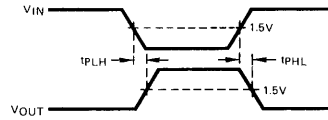
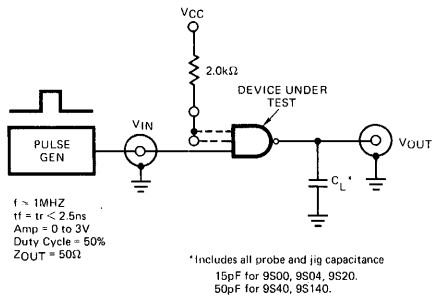

Fig. DD

TEST CIRCUIT AND WAVEFORM FOR 9S03, 9S05 AND 9S22

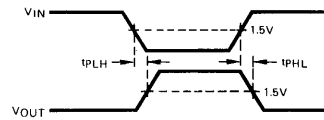
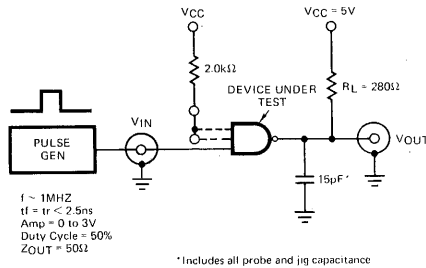

Fig. EE

FAIRCHILD SERIES TTL/SSI

SWITCHING CHARACTERISTICS (cont.)

TEST CIRCUIT AND WAVEFORM FOR 9S64, 9S65

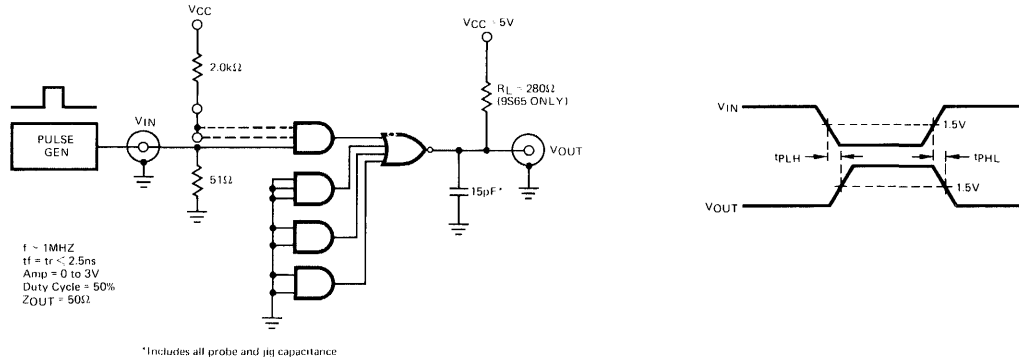

Fig. FF

TYPICAL CHARACTERISTICS

ADDED PROPAGATION DELAY TIME vs EXPANDER-NODE CAPACITANCE

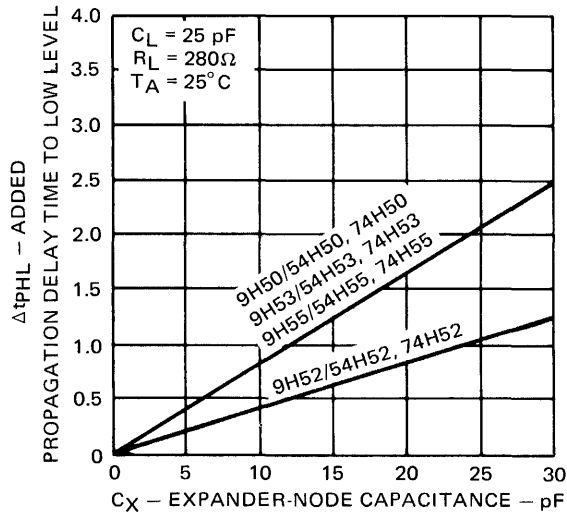

Fig. MM

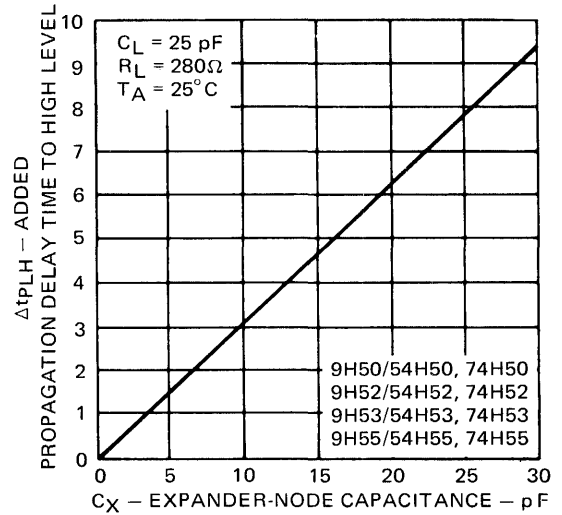
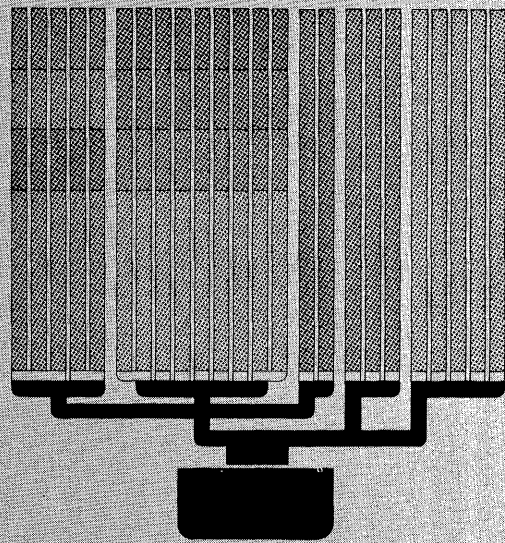

Fig. NN



**SSI
Monostable Multivibrator
and Interface Circuits
9600 Series Data Sheets**

The 9600 TTL elements are Monostable Multivibrator and Interface functions compatible with all SSI and MSI devices.

Full data sheets are provided on the Monostable series. Complete data sheets on the Interface series may be obtained from:

Fairchild Semiconductor
P.O. Box 880 A
Mountain View, California
94040

Attn: Distribution Services

7

8

9

10

11

12

TTL/MONOSTABLE 9600

RETRIGGERABLE RESETTABLE

MONOSTABLE MULTIVIBRATOR

DESCRIPTION — The TTL/Monostable 9600 Retriggerable, Resettable Monostable Multivibrator provides an output pulse whose duration and accuracy is a function of external timing components. The 9600 has excellent immunity to noise on the V_{CC} and ground lines. The 9600 uses TTL for high speed and high fanout capability and is compatible with all members of the Fairchild TTL family

- 74 ns TO ∞ OUTPUT PULSE WIDTH RANGE
- RETRIGGERABLE 0 TO 100% DUTY CYCLE
- RESETTABLE
- TTL INPUT GATING — LEADING OR TRAILING EDGE TRIGGERING
- COMPLEMENTARY TTL OUTPUTS
- OPTIONAL RETRIGGER LOCK-OUT CAPABILITY
- IMPROVED PULSE WIDTH TEMPERATURE STABILITY

ABSOLUTE MAXIMUM RATINGS (above which the useful life may be impaired)

Storage Temperature	-65°C to +150°C
Temperature (Ambient) Under Bias	-55°C to +125°C
V_{CC} Pin Potential to Ground (See Note 1)	-0.5 V to +8.0 V
Input Voltage (dc) (See Note 2)	-0.5 V to +5.5 V
Input Current (See Note 2)	-30 mA to +5.0 mA
Voltage Applied to Output When Output is HIGH	-0.5 V to + V_{CC} value
Current Into Output When Output is LOW	50 mA

NOTES:

- (1) The maximum V_{CC} value of 8.0 volts is not the primary factor in determining the maximum V_{CC} which may be applied to a number of interconnected devices. The voltage at a HIGH output is approximately 1 V_{BE} below the V_{CC} voltage, so the primary limit on the V_{CC} is that the voltage at any input may not go above 5.5 V unless the current is limited. This effectively limits the system V_{CC} to approximately 7.0 volts.
- (2) Because of the input clamp diodes, excess current can be drawn out of the inputs if the dc input voltage is more negative than -0.5 V. The diode is designed to clamp off large negative ac swings associated with fast fall times and long lines. This maximum rating is intended only to limit the steady state input voltage and current.

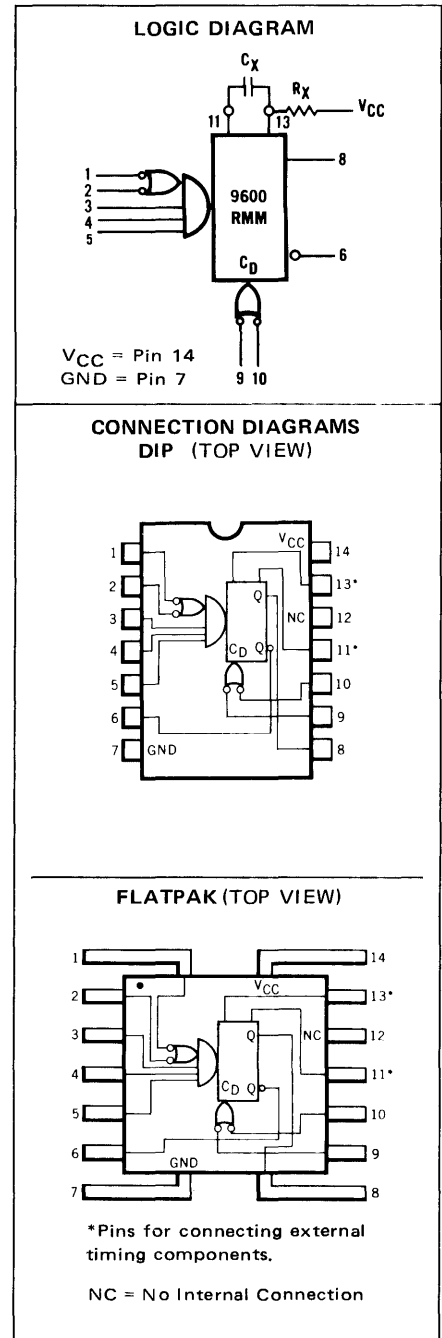

FUNCTIONAL DESCRIPTION – The 9600 monostable multivibrator has five inputs, three active HIGH and two active LOW. This allows leading edge or trailing edge triggering. The TTL inputs make triggering independent of input transition times. When input conditions for triggering are met, a new cycle starts and the external capacitor is rapidly discharged and then allowed to charge. An input cycle time shorter than the output cycle time will retrigger the 9600 and result in a continuous true output. (See Rule 8.) Retriggering may be inhibited by tying the negation (\bar{Q}) output to an active LOW input. The output pulse may be terminated at any time by connecting either or both reset pins to a LOW logic level pin. Active pullups are provided on the outputs for good drive capability into capacitive loads.

OPERATION RULES

1. An external resistor (R_X) and an external capacitor (C_X) are required as shown in the logic diagram. The value of R_X may vary from 5.0 to 50 k Ω for 0 to +75°C operation and from 5.0 to 25 k Ω for -55 to +125°C operation. C_X may vary from 0 to any necessary value available.
2. The following are recommended fixed values of R_X : $R_X = 30$ k Ω for 0 to +75°C operation, $R_X = 10$ k Ω for -55 to +125°C operation.
3. The output pulse width (t) is defined as follows:

$$t = 0.32 R_X C_X \left[1 + \frac{0.7}{R_X} \right]$$

Where R_X is in k Ω , C_X is in pF, t is in ns; for $C_X < 10^3$ pF, see Fig. 14.

The value of C_X may vary from 0 to any value necessary and obtainable. If however, C_X has leakage currents approaching 3 μ A or if stray capacitance from either pin 11 or pin 13 to ground exceeds 50 pF, the timing equation may not represent the pulse width obtained.

4. If electrolytic type capacitors are to be used, the following three configurations are recommended.

A. Use with low leakage electrolytic capacitors.

The normal RC configuration can be used predictably only if the forward capacitor leakage at 5.0 volts is less than 3 μ A, and the inverse capacitor leakage at 1.0 volts is less than 5 μ A over the operational temperature range and Rule 3 above is satisfied.

B. Use with high inverse leakage current electrolytic capacitors.

The diode in this configuration prevents high inverse leakage currents through the capacitor by preventing an inverse voltage across the capacitor.

$$t \approx 0.3 RC_X$$

The use of this configuration is not recommended with retriggerable operation.

C. Use to obtain extended pulse widths.

This configuration obtains extended pulse widths because of the larger timing resistor allowed by Beta multiplication.

Electrolytics with high inverse leakage currents can be used.

$$R < R_X (0.7) (h_{FE} Q_1) \text{ or } < 2.5 M\Omega, \text{ whichever is less}$$

$$R_X(\text{min}) < R_Y < R_X(\text{max}) \quad R_Y \text{ of 5 to 10k}\Omega \text{ is recommended.}$$

Q_1 : NPN silicon transistor with h_{FE} requirements of above equations, such as 2N5961 or 2N5962

$$t \approx 0.3 RC_X$$

The use of this configuration is not recommended with retriggerable operation.

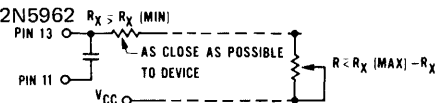
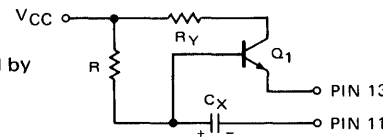
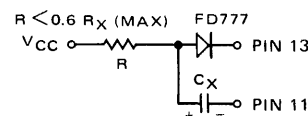
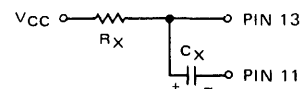

5. This circuit is recommended to obtain variable pulse width by remote trimming.
6. Under any operating condition, C_X and $R_X(\text{min})$ must be kept as close to the circuit as possible to minimize stray capacitance and reduce noise pickup.
7. Input Trigger Pulse Rules (see Triggering Truth Table, after Fig. 15).

Input to pin 1 or 2. Pins 2 or 1,3,4,5, 9,10 = HIGH.

$t_1, t_3 =$ Min. positive input pulse width > 40 ns.

$t_2, t_4 =$ Min. negative input pulse width > 40 ns.

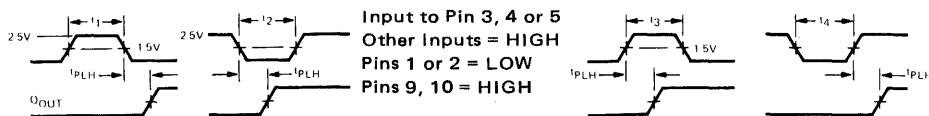

8. The retrigger pulse width is equal to the pulse width t plus a delay time. For pulse widths greater than 500 ns, t_w can be approximated as t .

$$t_w = t + t_{PLH} = 0.32 R_X C_X \left(1 + \frac{0.7}{R_X} \right) + t_{PLH}$$

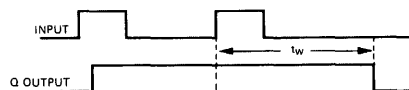

NOTE: Retriggering will not occur if the retrigger pulse comes within $\approx 0.3 C_X$ ns after the initial trigger pulse (i.e., during the discharge cycle time).

9. Two overriding active LOW resets are provided. A LOW to either or both resets can terminate any timing cycle and/or inhibit any new cycle until both reset inputs are restored to a HIGH. Trigger inputs will not produce spikes in the output when either or both resets are held LOW.

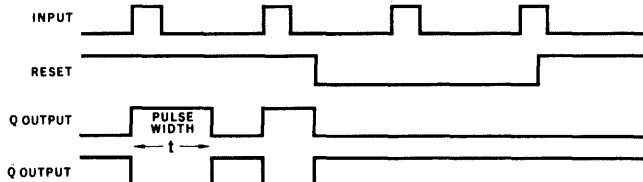

10. Use of a 0.01 to 0.1 μ F bypass capacitor located close to the 9600 is recommended.

FAIRCHILD TTL/MONOSTABLE • 9600

TABLE I – ELECTRICAL CHARACTERISTICS ($T_A = -55^\circ\text{C}$ to 125°C , $V_{CC} = 5\text{ V} \pm 10\%$) (Part No. 9600XM)*

SYMBOL	PARAMETER	LIMITS						UNITS	CONDITIONS (Note 1)	
		-55°C		$+25^\circ\text{C}$			$+125^\circ\text{C}$			
		MIN	MAX	MIN	TYP	MAX	MIN			MAX
V_{OH}	Output HIGH Voltage	2.4		2.4	3.3		2.4		Volts	$V_{CC} = 4.5\text{ V}$, $I_{OH} = -0.96\text{ mA}$ (Note 2)
V_{OL}	Output LOW Voltage		0.4		0.2	0.4		0.4	Volts	$V_{CC} = 4.5\text{ V}$, $I_{OL} = 9.92\text{ mA}$ (Note 2) $V_{CC} = 5.5\text{ V}$, $I_{OL} = 12.8\text{ mA}$
V_{IH}	Input HIGH Voltage	2.0		1.7			1.5		Volts	Guaranteed Input HIGH Threshold Voltage
V_{IL}	Input LOW Voltage		0.85		0.90			0.85	Volts	Guaranteed Input LOW Threshold Voltage
I_{IL}	Input LOW Current		-1.6		-1.1	-1.6		-1.6	mA	$V_{CC} = 5.5\text{ V}$, $V_{IN} = 0.4\text{ V}$
			-1.24		-0.97	-1.24		-1.24	mA	$V_{CC} = 4.5\text{ V}$, $V_{IN} = 0.4\text{ V}$
I_{IH}	Input HIGH Current				15	60		60	μA	$V_{CC} = 5.5\text{ V}$, $V_{IN} = 4.5\text{ V}$
I_{SC}	Short Circuit Current					-25			mA	$V_{CC} = 5.5\text{ V}$, $V_{OUT} = 1.0\text{ V}$ (Note 2)
I_{PD}	Quiescent Power Supply Drain		24		19	24		24	mA	$V_{CC} = 5.0\text{ V}$, Gnd Pins 1 & 2
t_{PLH}	Negative Trigger Input to True Output				29	45			ns	$V_{CC} = 5.0\text{ V}$ $R_X = 5.0\ \Omega$ $C_X = 0$, $C_L = 15\text{ pF}$
t_{PHL}	Negative Trigger Input to Complement Output				29	40			ns	$V_{CC} = 5.0\text{ V}$ $R_X = 5.0\ \Omega$ $C_X = 0$, $C_L = 15\text{ pF}$
$t_{(min)}$	Minimum True Output Pulse Width				74	100			ns	$V_{CC} = 5.0\text{ V}$ $R_X = 5.0\ \Omega$ $C_X = 0$, $C_L = 15\text{ pF}$
	Minimum Complement Output Pulse Width					112			ns	$V_{CC} = 5.0\text{ V}$ $R_X = 5.0\ \Omega$ $C_X = 0$, $C_L = 15\text{ pF}$
t	Pulse Width			3.20	3.42	3.76			μs	$V_{CC} = 5.0\text{ V}$, $R_X = 10\text{ k}\Omega$, $C_X = 1000\text{ pF}$
C_{STRAY}	Maximum Allowable Wiring Cap. (Pin 13)		50			50		50	pF	Pin 13 to Ground
R_X	Timing Resistor	5.0	25	5.0		25		5.0	25	$\text{k}\Omega$

TABLE II – ELECTRICAL CHARACTERISTICS ($T_A = 0^\circ\text{C}$ to 75°C , $V_{CC} = 5\text{ V} \pm 5\%$) (Part No. 9600XC)*

SYMBOL	PARAMETER	LIMITS						UNITS	CONDITIONS (Note 1)	
		0°C		$+25^\circ\text{C}$			75°C			
		MIN	MAX	MIN	TYP	MAX	MIN			MAX
V_{OH}	Output HIGH Voltage	2.4		2.4	3.4		2.4		Volts	$V_{CC} = 4.75\text{ V}$, $I_{OH} = -0.96\text{ mA}$ (Note 2)
V_{OL}	Output LOW Voltage		0.45		0.2	0.45		0.45	Volts	$V_{CC} = 4.75\text{ V}$, $I_{OL} = 11.3\text{ mA}$ (Note 2) $V_{CC} = 5.25\text{ V}$, $I_{OL} = 12.8\text{ mA}$
V_{IH}	Input HIGH Voltage	1.9		1.8			1.65		Volts	Guaranteed Input HIGH Threshold Voltage
V_{IL}	Input LOW Voltage		0.85		0.85			0.85	Volts	Guaranteed Input LOW Threshold Voltage
I_{IL}	Input LOW Current		-1.6		-1.0	-1.6		-1.6	mA	$V_{CC} = 5.25\text{ V}$, $V_{IN} = 0.45\text{ V}$
			-1.41		-1.41		-1.41		-1.41	mA
I_{IH}	Input HIGH Current				15	60		60	μA	$V_{CC} = 5.25\text{ V}$, $V_{IN} = 4.5\text{ V}$
I_{SC}	Short Circuit Current					-35			mA	$V_{CC} = 5.25\text{ V}$, $V_{OUT} = 1.0\text{ V}$ (Note 2)
I_{PD}	Quiescent Power Supply		26		19	26		26	mA	$V_{CC} = 5.0\text{ V}$ Ground Pins 1 and 2
t_{PLH}	Negative Trigger Input to True Output				29	56			ns	$V_{CC} = 5.0\text{ V}$ $R_X = 5.0\text{ k}\Omega$ $C_X = 0$, $C_L = 15\text{ pF}$
t_{PHL}	Negative Trigger Input to Complement Output				29	47			ns	$V_{CC} = 5.0\text{ V}$ $R_X = 5.0\text{ k}\Omega$ $C_X = 0$, $C_L = 15\text{ pF}$
$t_{(min)}$	Minimum True Output Pulse Width				74	120			ns	$V_{CC} = 5.0\text{ V}$ $R_X = 5.0\text{ k}\Omega$ $C_X = 0$, $C_L = 15\text{ pF}$
	Minimum Complement Output Pulse Width					130			ns	$V_{CC} = 5.0\text{ V}$ $R_X = 5.0\text{ k}\Omega$ $C_X = 0$, $C_L = 15\text{ pF}$
t	Pulse Width			3.08	3.42	3.76			μs	$V_{CC} = 5.0\text{ V}$, $R_X = 10\text{ k}\Omega$, $C_X = 1000\text{ pF}$
C_{STRAY}	Maximum Allowable Wiring Cap. (Pin 13)		50			50		50	pF	Pin 13 to Ground
R_X	Timing Resistor	5.0	50	5.0		50		5.0	50	$\text{k}\Omega$

* X = package type; F for Flatpak, D for Ceramic Dip, P for Plastic Dip. See Packaging Information Section for packages available on this product.

NOTES:

- (1) Unless otherwise noted, 10 k Ω resistor placed between Pin 13 and V_{CC} , for all tests. (R_X)
- (2) Ground Pin 11 for V_{OL} Pin 6 or V_{OH} Pin 8 or I_{SC} Pin 8.
Open Pin 11 for V_{OL} Pin 8 or V_{OH} Pin 6 or I_{SC} Pin 6.

TYPICAL ELECTRICAL CHARACTERISTICS

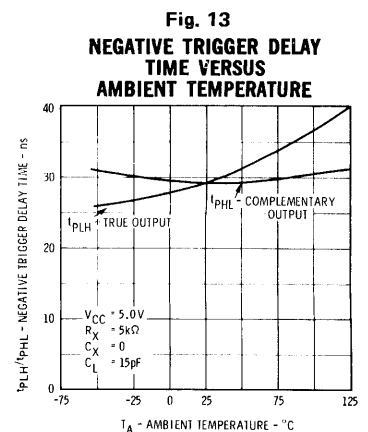
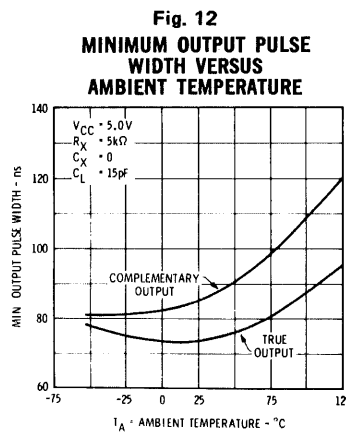
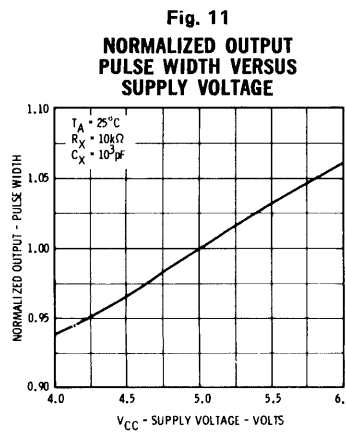
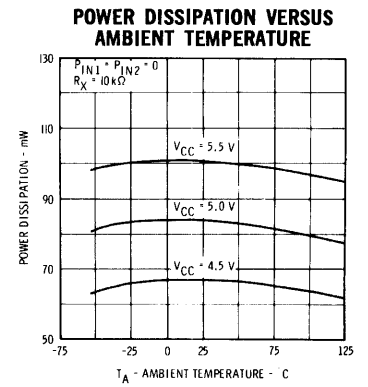
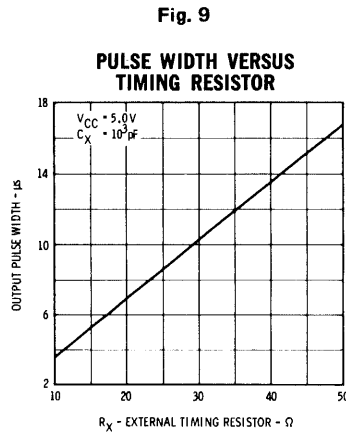
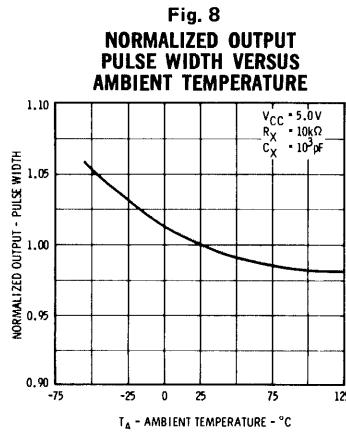
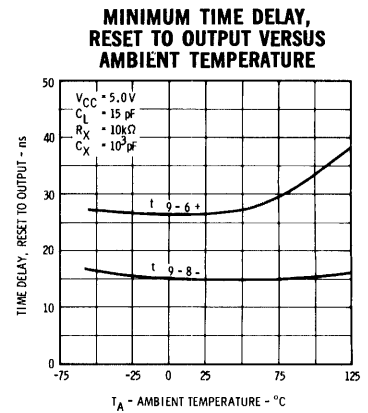
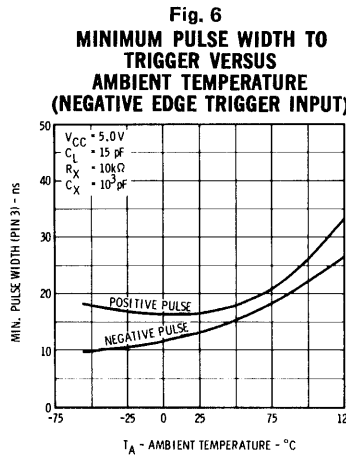
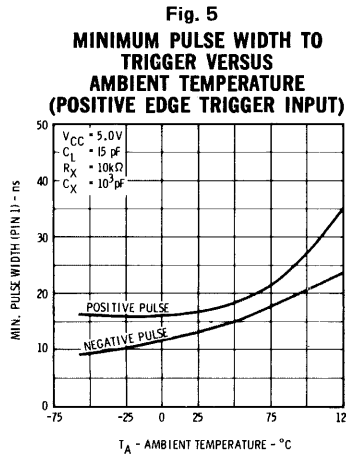
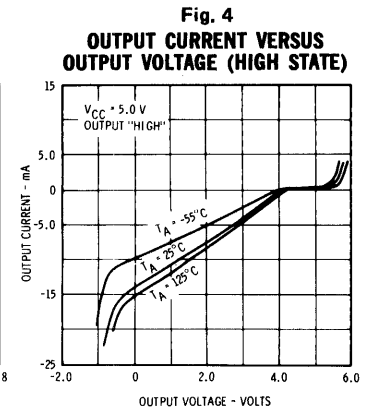
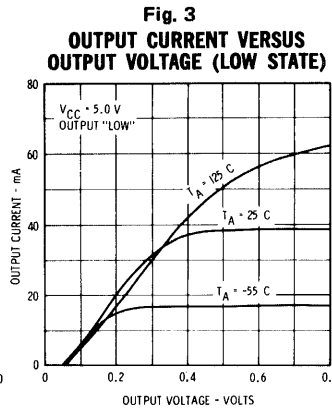
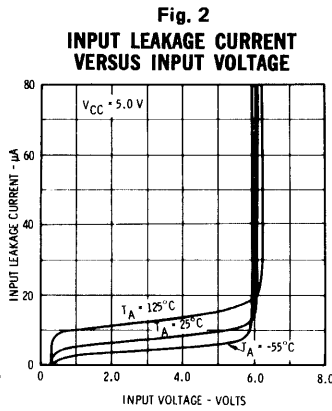
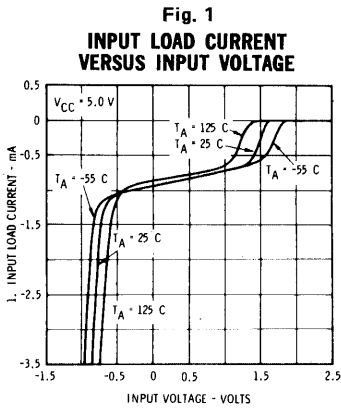

OUTPUT PULSE WIDTH VERSUS TIMING RESISTANCE AND CAPACITANCE FOR $C_X < 10^3 \text{ pF}$

[For $C_X \geq 10^3 \text{ pF}$, $t = 0.32 R_X C_X (1 + \frac{0.7}{R_X})$]

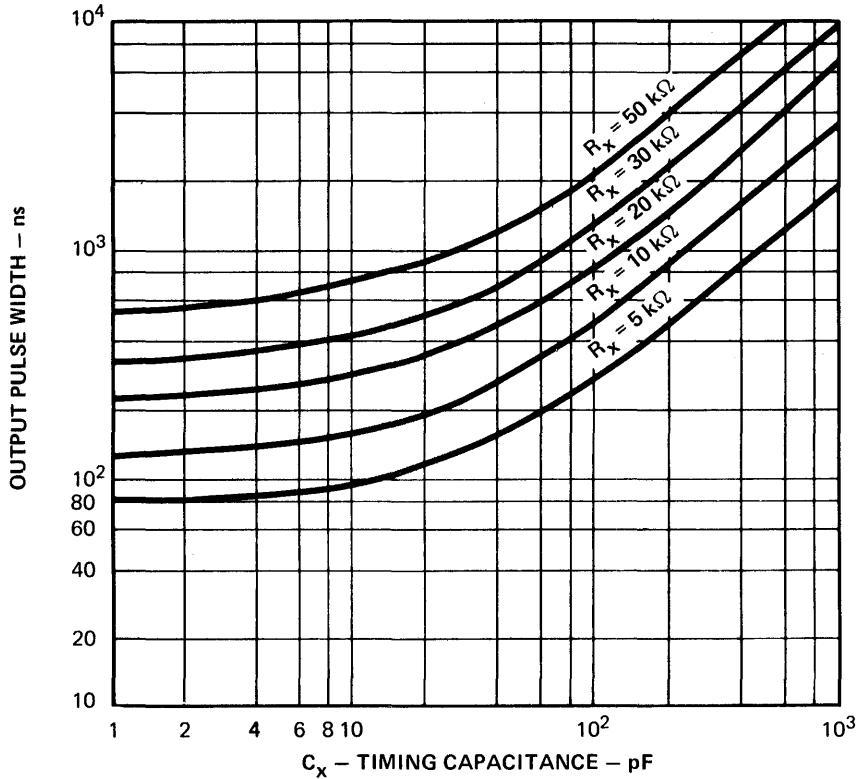
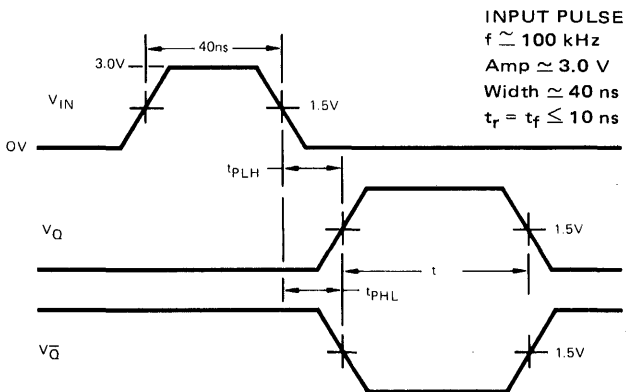
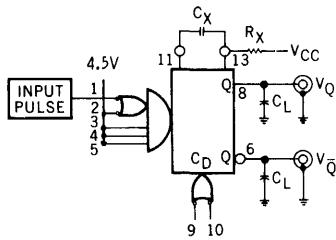

Fig. 14

SWITCHING TIME TEST CIRCUIT AND WAVEFORMS



INPUT PULSE
 $f \approx 100 \text{ kHz}$
 Amp $\approx 3.0 \text{ V}$
 Width $\approx 40 \text{ ns}$
 $t_r = t_f \leq 10 \text{ ns}$

NOTE: Capacitance includes Jig and Probe

Fig. 15

LOADING RULES

TTL INPUT LOAD AND DRIVE FACTORS

INPUTS	LOAD	
	HIGH	LOW
1,2,3,4,5,9,10	1 U.L.	1 U.L.

OUTPUTS	DRIVE FACTOR	
	HIGH	LOW
6,8	16 U.L.	8 U.L.

Note: 1 Unit Load (U.L.) = 60 μA HIGH/1.6 mA LOW.

TRIGGERING TRUTH TABLE

1	(PIN NO.'S.)						OPERATION
	2	3	4	5	9	10	
H→L	H	H	H	H	H	H	Trigger
H	H→L	H	H	H	H	H	Trigger
L	X	L→H	H	H	H	H	Trigger
X	L	L→H	H	H	H	H	Trigger
L	X	H	L→H	H	H	H	Trigger
X	L	H	L→H	H	H	H	Trigger
L	X	H	H	L→H	H	H	Trigger
X	L	H	H	L→H	H	H	Trigger
X	X	X	X	X	L	X	Reset
X	X	X	X	X	X	L	Reset

H = HIGH Voltage Level H→L = Transition from HIGH to LOW Voltage level
 L = LOW Voltage Level
 X = Don't Care L→H = Transition from LOW to HIGH Voltage level

TTL/MONOSTABLE 9601

RETRIGGERABLE MONOSTABLE MULTIVIBRATOR

DESCRIPTION – The TTL/Monostable 9601 Retriggerable Monostable Multivibrator provides an output pulse whose duration and accuracy is a function of external timing components. The 9601 has excellent immunity to noise on the V_{CC} and ground lines. The 9601 uses TTL for high speed and high fanout capability and is compatible with all members of the Fairchild TTL family.

FEATURES:

- 50 ns TO ∞ OUTPUT PULSE WIDTH RANGE
- RETRIGGERABLE 0 TO 100% DUTY CYCLE
- TTL INPUT GATING – LEADING OR TRAILING EDGE TRIGGERING
- COMPLEMENTARY TTL OUTPUTS
- OPTIONAL RETRIGGER LOCK-OUT CAPABILITY
- PULSE WIDTH COMPENSATED FOR V_{CC} AND TEMPERATURE VARIATIONS

ABSOLUTE MAXIMUM RATINGS (above which the useful life may be impaired)

Storage Temperature	-65°C to +150°C
Temperature (Ambient) Under Bias	-55°C to +125°C
V_{CC} Pin Potential to Ground (See Note 1)	-0.5 V to +8.0 V
Input Voltage (dc) (See Note 2)	-0.5 V to +5.5 V
Input Current (See Note 2)	-30 mA to +5.0 mA
Voltage Applied to Output When Output is HIGH	-0.5 V to + V_{CC} value
Current Into Output When Output is LOW	50 mA

NOTES:

- (1) The maximum V_{CC} value of 8.0 volts is not the primary factor in determining the maximum V_{CC} which may be applied to a number of interconnected devices. The voltage at a HIGH output is approximately 1 V_{BE} below the V_{CC} voltage, so the primary limit on the V_{CC} is that the voltage at any input may not go above 5.5 V unless the current is limited. This effectively limits the system V_{CC} to approximately 7.0 volts.
- (2) Because of the input clamp diodes, excess current can be drawn out of the inputs if the dc input voltage is more negative than -0.5 V. The diode is designed to clamp off large negative ac swings associated with fast fall times and long lines. This maximum rating is intended only to limit the steady state input voltage and current.

LOGIC DIAGRAM

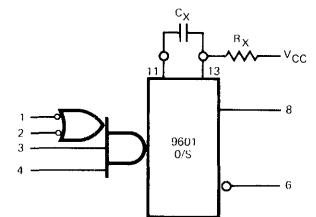

V_{CC} = Pin 14
GND = Pin 7

CONNECTION DIAGRAMS DIP (TOP VIEW)

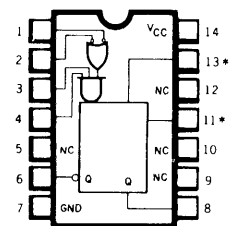

FLATPAK (TOP VIEW)

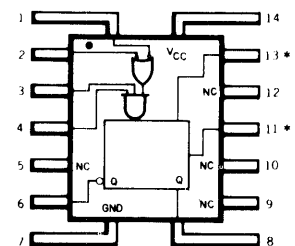

*Pins for External Timing
NC - No Internal Connection

FAIRCHILD TTL/MONOSTABLE • 9601

FUNCTIONAL DESCRIPTION

The 9601 monostable multivibrator has four inputs, two active HIGH and two active LOW. This allows a choice of leading edge or trailing edge triggering. The TTL inputs make triggering independent of input transition times. When input conditions for triggering are met, a new cycle starts and the external capacitor is rapidly discharged and then allowed to charge. An input cycle time shorter than the output cycle time will retrigger the 9601 and result in a continuous true output. (See Rule 9.) Retriggering may be inhibited by tying the negation (Q) output to an active LOW input. Active pullups are provided on the outputs for good drive capability into capacitive loads.

OPERATION RULES

1. An external resistor (R_X) and external capacitor (C_X) are required as shown in the Logic Diagram.
2. The value of R_X may vary from 5.0 to 50 k Ω for 0 to 75°C operation and from 5.0 to 25 k Ω for -55 to +125°C operation.
3. C_X may vary from 0 to any necessary value available. If however, the capacitor has leakages approaching 3.0 μ A or if stray capacitance from either terminal to ground is more than 50 pF, the timing equations may not represent the pulse width obtained.
4. The output pulse with (t) is defined as follows:

$$t = 0.32 R_X C_X \left[1 + \frac{0.7}{R_X} \right] \quad \text{Where } R_X \text{ is in k}\Omega, C_X \text{ is in pF, } t \text{ is in ns; for } C_X < 10^3 \text{ pF, see Fig. 12.}$$

5. If electrolytic type capacitors are to be used, the following three configurations are recommended:

- A. For use with low leakage electrolytic capacitors.
The normal RC configuration can be used predictably only if the forward capacitor leakage at 5.0 volts is less than 3 μ A, and the inverse capacitor leakage at 1.0 volt is less than 5 μ A over the operational temperature range, and Rule 3 above is satisfied.
- B. Use with high inverse leakage current electrolytic capacitors.
The diode in this configuration prevents high inverse leakage currents through the capacitor by preventing an inverse voltage across the capacitor.

$$t \approx 0.3 RC_X$$

- C. Use to obtain extended pulse widths:
This configuration obtains extended pulse widths, because of the larger timing resistor allowed by Beta multiplication. Electrolytics with high (>5 μ A) inverse leakage currents can be used.

$$R < R_X (0.7) (h_{FE} Q_1) \text{ or } < 2.5 \text{ M}\Omega \text{ whichever is lesser}$$

$$R_X (\text{min}) < R_Y < R_X (\text{max}) \quad (5 \leq R_Y \leq 10 \text{ k}\Omega \text{ is recommended})$$

Q_1 : NPN silicon transistor with h_{FE} requirements of above equations, such as 2N5961 or 2N5962

$$t \approx 0.3 RC_X$$

Configuration B and C are not recommended with retriggerable operation.

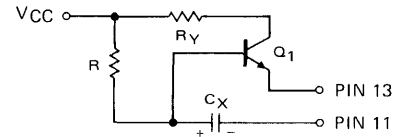
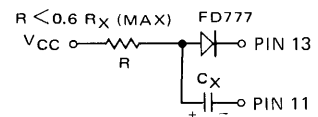
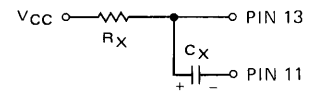

6. To obtain variable pulse width by remote trimming, the following circuit is recommended:

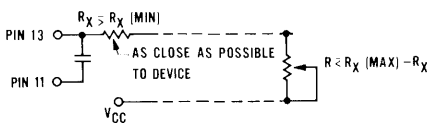

7. Under any operating condition, C_X and R_X (min) must be kept as close to the circuit as possible to minimize stray capacitance and reduce noise pickup.

8. Input Trigger Pulse Rules. (See Triggering Truth Table on page 5.)

Input to Pin 1 (2)

Pins 2, (1), 3 & 4 = HIGH

t_1, t_4 = Setup time > 40 ns

t_2, t_3 = Release time > 40 ns

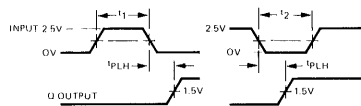

Input to Pin 3 (4)

Pin 4 (3) = HIGH

Pins 1 or 2 = LOW

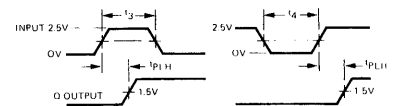

9. The retrigger pulse width is calculated as shown below:

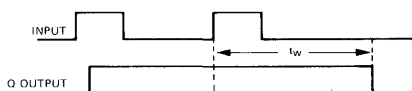

$$t_w = t + t_{PLH} = 0.32 R_X C_X \left(1 + \frac{0.7}{R_X} \right) + t_{PLH}$$

The retrigger pulse width is equal to the pulse width t plus a delay time. For pulse widths greater than 500 ns, t_w can be approximated as t .

NOTE: Retriggering will not occur if the retrigger pulse comes within $\approx 0.3 C_X$ ns after the initial trigger pulse. (i.e., during the discharge cycle time.)

10. Use of a 0.01 to 0.1 μ F bypass capacitor between V_{CC} and Ground located close to the 9601 is recommended.

FAIRCHILD TTL/MONOSTABLE • 9601

TABLE I – ELECTRICAL CHARACTERISTICS ($T_A = -55^\circ\text{C}$ to 125°C , $V_{CC} = 5\text{ V} \pm 10\%$) (Part No. 9601XM)*

SYMBOL	PARAMETER	LIMITS						UNITS	CONDITIONS (Note 1)	
		-55°C		+25°C		+125°C				
		MIN.	MAX.	MIN.	TYP.	MAX.	MIN.			MAX.
V_{OH}	Output HIGH Voltage	2.4		2.4	3.3		2.4	Volts	$V_{CC} = 4.5\text{ V}$, $I_{OH} = -0.72\text{ mA}$ (Note 2)	
V_{OL}	Output LOW Voltage		0.4		0.2	0.4		0.4	Volts	$V_{CC} = 4.5\text{ V}$, $I_{OL} = 10\text{ mA}$ (Note 2)
V_{IH}	Input HIGH Voltage (Note 3)	2.0		1.7			1.5	Volts	Guaranteed Input HIGH Threshold	
V_{IL}	Input LOW Voltage (Note 3)		0.85			0.90		0.85	Volts	Guaranteed Input LOW Threshold
I_{IL}	Input LOW Current		-1.6		-1.1	-1.6		-1.6	mA	$V_{CC} = 5.5\text{ V}$ $V_{IN} = 0.4\text{ V}$
I_{IH}	Input HIGH Current				15	60		60	μA	$V_{CC} = 5.5\text{ V}$, $V_{IN} = 4.5\text{ V}$
I_{SC}	Short Circuit Current			-10		-40			mA	$V_{CC} = 5.0\text{ V}$, $V_{OUT} = 0\text{ V}$ (Note 2)
I_{PD}	Quiescent Power Supply Drain		25			25		25	mA	$V_{CC} = 5.5\text{ V}$, Ground Pins 1 and 2
t_{PLH}	Negative Trigger Input to True Output				25	40			ns	$V_{CC} = 5.0\text{ V}$ $R_X = 5.0\text{ k}\Omega$ $C_X = 0$, $C_L = 15\text{ pF}$
t_{PHL}	Negative Trigger Input to Complement Output				25	40			ns	$V_{CC} = 5.0\text{ V}$ $R_X = 5.0\text{ k}\Omega$ $C_X = 0$, $C_L = 15\text{ pF}$
t (min)	Minimum True Output Pulse Width				45	65			ns	$V_{CC} = 5.0\text{ V}$ $R_X = 5.0\text{ k}\Omega$ $C_X = 0$, $C_L = 15\text{ pF}$
t	Pulse Width			3.08	3.42	3.76			μs	$V_{CC} = 5.0\text{ V}$, $R_X = 10\text{ k}\Omega$, $C_X = 1000\text{ pF}$
C_{STRAY}	Maximum Allowable Wiring Cap. (Pin 13)		50			50		50	pF	Pin 13 to Ground
R_X	Timing Resistor	5.0	25	5.0		25	5.0	25	$\text{k}\Omega$	

TABLE II – ELECTRICAL CHARACTERISTICS ($T_A = 0^\circ\text{C}$ to 75°C , $V_{CC} = 5\text{ V} \pm 5\%$) (Part No. 9601XC)*

SYMBOL	PARAMETER	LIMITS						UNITS	CONDITIONS (Note 1)	
		0°C		+25°C		+75°C				
		MIN.	MAX.	MIN.	TYP.	MAX.	MIN.			MAX.
V_{OH}	Output HIGH Voltage	2.4		2.4	3.4		2.4	Volts	$V_{CC} = 4.75\text{ V}$, $I_{OH} = -0.96\text{ mA}$ (Note 2)	
V_{OL}	Output LOW Voltage		0.45		0.2	0.45		0.45	Volts	$V_{CC} = 4.75\text{ V}$, $I_{OL} = 12.8\text{ mA}$ (Note 2)
V_{IH}	Input HIGH Voltage (Note 3)	1.9		1.8			1.6	Volts	Guaranteed Input HIGH Threshold	
V_{IL}	Input LOW Voltage (Note 3)		.85			0.85		0.85	Volts	Guaranteed Input LOW Threshold
I_{IL}	Input LOW Current		-1.6		-1.0	-1.6		-1.6	mA	$V_{CC} = 5.25\text{ V}$ $V_{IN} = 0.45\text{ V}$
I_{IH}	Input HIGH Current				15	60		60	μA	$V_{CC} = 5.25\text{ V}$, $V_{IN} = 4.5\text{ V}$
I_{SC}	Short Circuit Current			-10		-40			mA	$V_{CC} = 5.0\text{ V}$, $V_{OUT} = 0\text{ V}$ (Note 2)
I_{PD}	Quiescent Power Supply Drain		25			25		25	mA	$V_{CC} = 5.25\text{ V}$, Ground Pins 1 and 2
t_{PLH}	Negative Trigger Input to True Output				25	40			ns	$V_{CC} = 5.0\text{ V}$, $R_X = 5.0\text{ k}\Omega$, $C_X = 0$, $C_L = 15\text{ pF}$
t_{PHL}	Negative Trigger Input to Complement Output				25	40			ns	$V_{CC} = 5.0\text{ V}$, $R_X = 5.0\text{ k}\Omega$, $C_X = 0$, $C_L = 15\text{ pF}$
t (min)	Minimum True Output Pulse Width				45	65			ns	$V_{CC} = 5.0\text{ V}$, $R_X = 5.0\text{ k}\Omega$, $C_X = 0$, $C_L = 15\text{ pF}$
t	Pulse Width			3.08	3.42	3.76			μs	$V_{CC} = 5.0\text{ V}$, $R_X = 10\text{ k}\Omega$, $C_X = 1000\text{ pF}$
C_{STRAY}	Maximum Allowable Wiring Cap. (Pin 13)		50			50		50	pF	Pin 13 to Ground
R_X	Timing Resistor	5.0	50	5.0		50	5.0	50	$\text{k}\Omega$	

X = package type; F for Flatpak, D for Ceramic Dip, P for Plastic Dip. See Packaging Information Section for packages available on this product.

NOTES:

- (1) Unless otherwise noted, 10 $\text{k}\Omega$ resistor placed between Pin 13 and V_{CC} , for all tests. (R_X)
- (2) Ground Pin 11 for V_{OL} Pin 6 or V_{OH} Pin 8 or I_{SC} Pin 8. Open Pin 11 for V_{OL} Pin 8 or V_{OH} Pin 6 or I_{SC} Pin 6.
- (3) Pulse Test to determine V_{IH} and V_{IL} (Min PW 40 ns).

TYPICAL ELECTRICAL CHARACTERISTICS

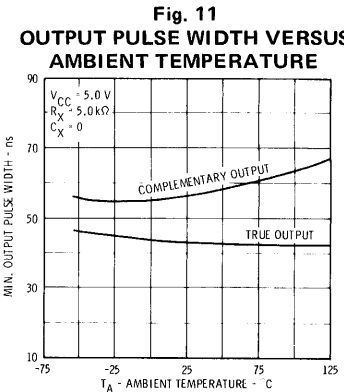
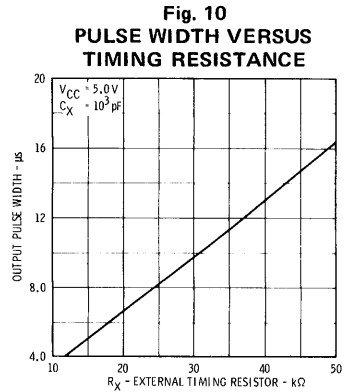
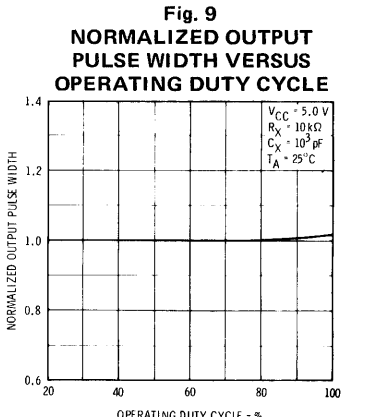
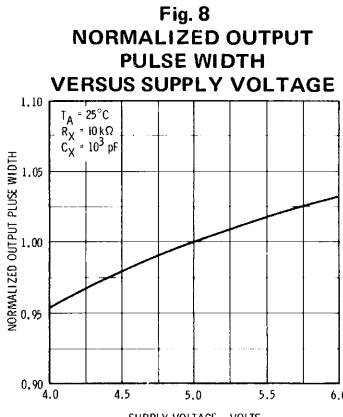
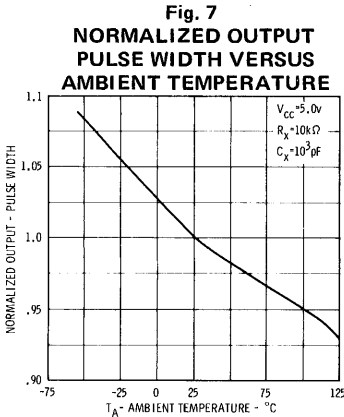
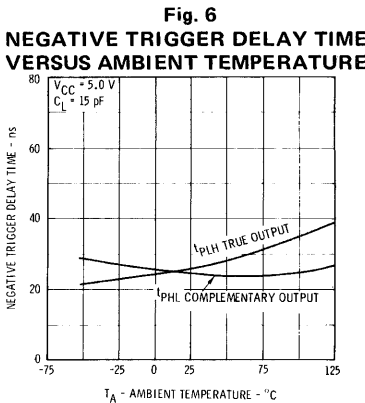
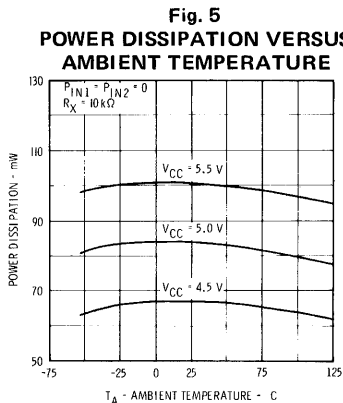
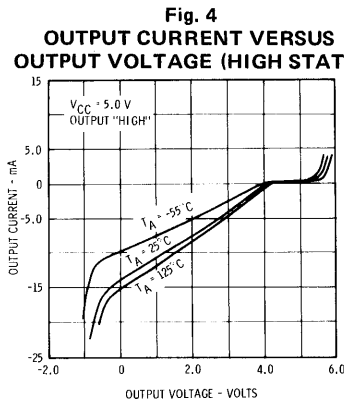
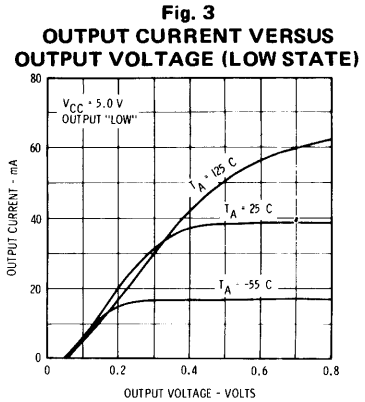
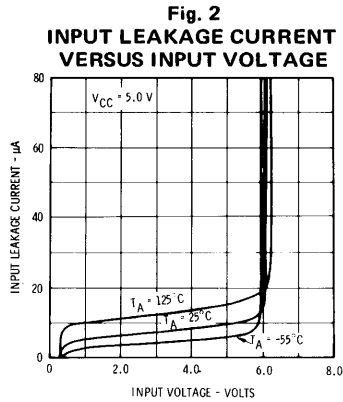
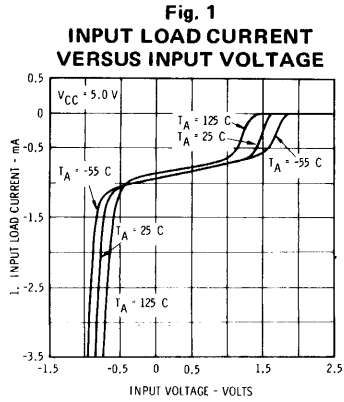

OUTPUT PULSE WIDTH VERSUS TIMING RESISTANCE AND CAPACITANCE FOR $C_X < 10^3$ pF

$$\left[\text{For } C_X \geq 10^3 \text{ pF, } t = 0.32 R_X C_X \left(1 + \frac{0.7}{R_X} \right) \right]$$

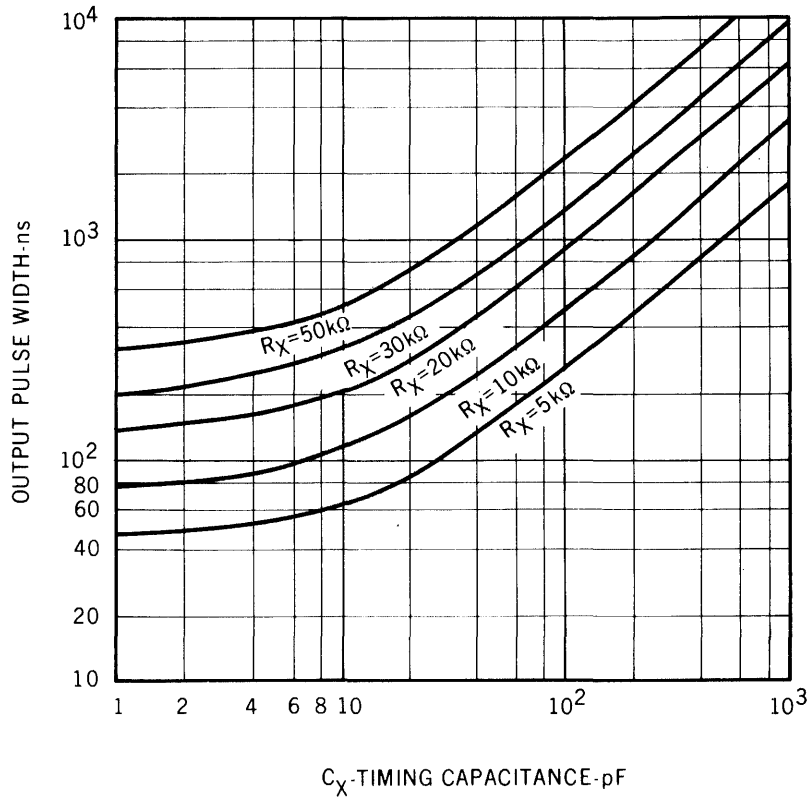
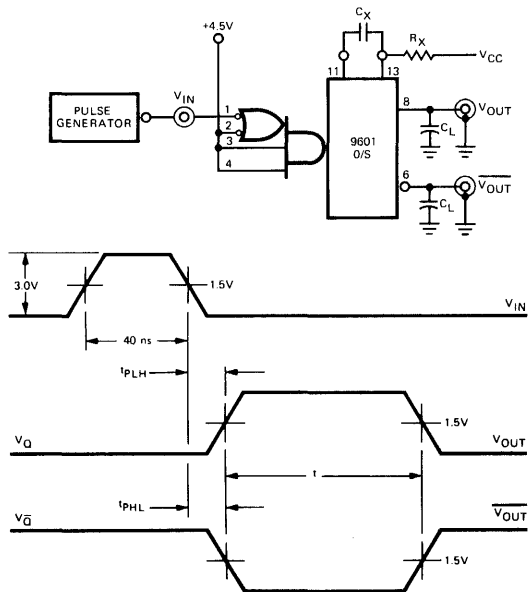

Fig. 12

SWITCHING TIME TEST CIRCUIT AND WAVEFORMS



NOTE: Capacitance includes Jig and Probe

LOADING RULES
TTL INPUT LOAD
AND DRIVE FACTORS

-55°C to +125°C

INPUT LEVEL	LOAD FACTOR
HIGH	1
LOW	1
OUTPUT STATE	DRIVE FACTOR
HIGH	12
LOW	6

0°C to 75°C

INPUT LEVEL	LOAD FACTOR
HIGH	1
LOW	1
OUTPUT STATE	DRIVE FACTOR
HIGH	16
LOW	8

TRIGGERING TRUTH TABLE

Pin Number				Operation
1	2	3	4	
H→L	H	H	H	Trigger
H	H→L	H	H	Trigger
L	X	L→H	H	Trigger
X	L	L→H	H	Trigger
L	X	H	L→H	Trigger
X	L	H	L→H	Trigger

$$T (\text{trigger}) = (\bar{1} + \bar{2}) \cdot 3 \cdot 4$$

Change of T from FALSE to TRUE causes trigger.

H = HIGH voltage level $\geq V_{IH}$

L = LOW voltage level $\leq V_{IL}$

L→H = transition from LOW to HIGH voltage level

H→L = transition from HIGH to LOW voltage level

X = Don't care (either HIGH or LOW voltage level)

TTL/MONOSTABLE 9602

DUAL RETRIGGERABLE RESETTABLE MONOSTABLE MULTIVIBRATOR

DESCRIPTION – The TTL/Monostable 9602 Dual Retriggerable, Resettable Monostable Multivibrator provides an output pulse whose duration and accuracy is a function of external timing components. The 9602 has excellent immunity to noise on the V_{CC} and ground lines. The 9602 uses TTL inputs and outputs for high speed and high fanout capability and is compatible with all members of the Fairchild TTL family.

- 72 ns TO ∞ OUTPUT WIDTH RANGE
- RETRIGGERABLE 0 TO 100% DUTY CYCLE
- TTL INPUT GATING – LEADING OR TRAILING EDGE TRIGGERING
- COMPLEMENTARY TTL OUTPUTS
- OPTIONAL RETRIGGER LOCK-OUT CAPABILITY
- PULSE WIDTH COMPENSATED FOR V_{CC} AND TEMPERATURE VARIATIONS
- RESETTABLE

ABSOLUTE MAXIMUM RATINGS (above which the useful life may be impaired)

Storage Temperature	-65°C to +150°C
Temperature (Ambient) Under Bias	-55°C to +125°C
V_{CC} Pin Potential to Ground (See Note 1)	-0.5 V to +8.0 V
Input Voltage (dc) (See Note 2)	-0.5 V to +5.5 V
Input Current (See Note 2)	-30 mA to +5.0 mA
Voltage Applied to Output When Output is HIGH	-0.5 V to + V_{CC} value
Current Into Output When Output is LOW	50 mA

NOTES:

1. The maximum V_{CC} value of 8.0 volts is not the primary factor in determining the maximum V_{CC} which may be applied to a number of interconnected devices. The voltage at a HIGH output is approximately 1 V_{BE} below the V_{CC} voltage, so the primary limit on the V_{CC} is that the voltage at any input may not go above 5.5 V unless the current is limited. This effectively limits the system V_{CC} to approximately 7.0 volts.
2. Because of the input clamp diodes, excess current can be drawn out of the inputs if the dc input voltage is more negative than -0.5 V. The diode is designed to clamp off large negative ac swings associated with fast fall times and long lines. This maximum rating is intended only to limit the steady state input voltage and current.

CONNECTION DIAGRAMS
DIP (TOP VIEW)

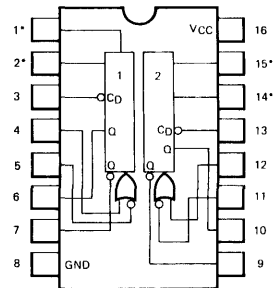

*Pins for external timing.

FLATPAK (TOP VIEW)

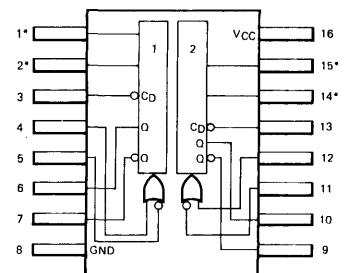

*Pins for external timing.

LOGIC DIAGRAM

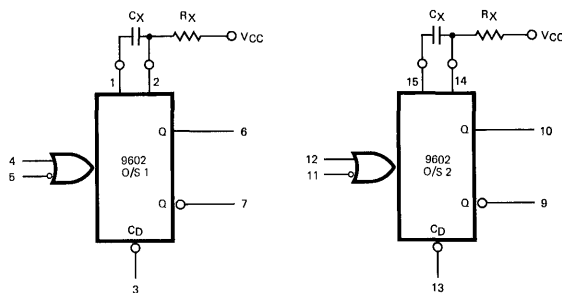

FUNCTIONAL DESCRIPTION — The 9602 dual resettable, retriggerable monostable multivibrator has two inputs per function, one active LOW and one active HIGH. This allows leading edge or trailing edge triggering. The TTL inputs make triggering independent of input transition times. When input conditions for triggering are met, a new cycle starts and the external capacitor is rapidly discharged and then allowed to charge. An input cycle time shorter than the output cycle time will retrigger the 9602 and result in a continuous true output. (See Rule 9) The output pulse may be terminated at any time by connecting the reset pin to a logic level LOW. Active pullups are provided on the outputs for good drive capability into capacitive loads. Retriggering may be inhibited by tying \bar{Q} output to an active level LOW input or the Q output to the active level HIGH input.

OPERATION RULES

1. An external resistor (R_X) and external capacitor (C_X) are required as shown in the Logic Diagram.
2. The value of R_X may vary from 5.0 k Ω to 50 k Ω for 0 to 75°C operation. The value of R_X may vary from 5.0 k Ω to 25 k Ω for -55 to +125°C operation.
3. The value of C_X may vary from 0 to any necessary value available. If, however, the capacitor has leakages approaching 3.0 μ A or if stray capacitance from either terminal to ground is more than 50 pF, the timing equations may not represent the pulse width obtained.
4. The output pulse with (t) is defined as follows:

$$t = 0.31 R_X C_X \left[1 + \frac{1}{R_X} \right] \quad \text{Where}$$

R_X is in k Ω , C_X is in pF
t is in ns
for $C_X < 10^3$ pF, see Fig. 14

5. If electrolytic type capacitors are to be used, the following three configurations are recommended:

A. Use with low leakage capacitors:

The normal RC configuration can be used predictably only if the forward capacitor leakage at 5.0 volts is less than 3 μ A, and the inverse capacitor leakage at 1.0 volt is less than 5 μ A over the operational temperature range and Rule 3 above is satisfied.

B. Use with high inverse leakage current electrolytic capacitors:

The diode in this configuration prevents high inverse leakage currents through the capacitor by preventing an inverse voltage across the capacitor. The use of this configuration is not recommended with retriggerable operation.

$$t \approx 0.3 RC_X$$

C. Use to obtain extended pulse widths:

This configuration can be used to obtain extended pulse widths, because of the larger timing resistor allowed by beta multiplication. Electrolytics with high inverse leakage currents can be used.

$$R < R_X (0.7) (h_{FE} Q_1) \text{ or } < 2.5 M\Omega \text{ whichever is the lesser}$$

$$R_X (\text{min})' < R_Y < R_X (\text{max}) \quad (5 \leq R_Y \leq 10 \text{ k}\Omega \text{ is recommended})$$

Q₁: NPN silicon transistor with h_{FE} requirements of above equations, such as 2N5961 or 2N5962

$$t \approx 0.3 RC_X$$

This configuration is not recommended with retriggerable operation.

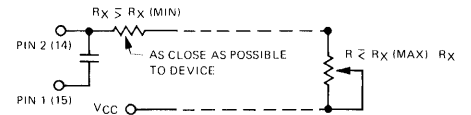
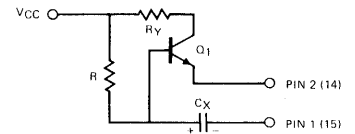
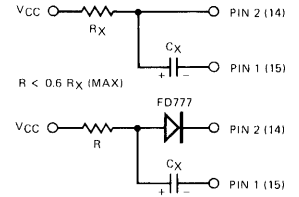

6. To obtain variable pulse width by remote trimming, the following circuit is recommended:

7. Under any operating condition, C_X and R_X (min) must be kept as close to the circuit as possible to minimize stray capacitance and reduce noise pickup.

8. Input Trigger Pulse Rules. See Triggering Truth Table, following pages.

Input to Pin 5 (11)

Pin 4 (12) = LOW

Pin 3 (13) = HIGH

t_1, t_3 = Min. Positive Input

Pulse Width > 40 ns

t_2, t_4 = Min. Negative Input

Pulse Width > 40 ns

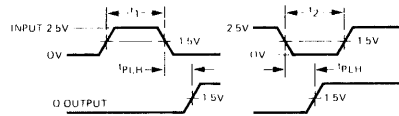

Input to Pin 4 (12)

Pin 5 (11) = HIGH

Pin 3 (13) = HIGH

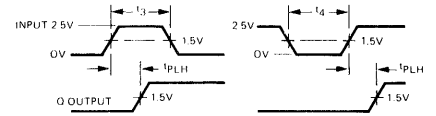

9. The retriggerable pulse width is calculated as shown below:

$$t_w = t + t_{PLH} = 0.31 R_X C_X \left(1 + \frac{1}{R_X} \right) + t_{PLH}$$

The retrigger pulse width is equal to the pulse width (t) plus a delay time.

For pulse widths greater than 500 ns, t_w can be approximated as t.

Retriggering will not occur if the retrigger pulse comes within $\approx 0.3 C_X$ ns after the initial trigger pulse. (i.e., during the discharge cycle)

10. Reset Operation — An overriding active LOW level is provided on each oneshot. By applying a LOW to the reset, any timing cycle can be terminated or any new cycle inhibited until the LOW reset input is removed. Trigger inputs will not produce spikes in the output when the reset is held LOW.

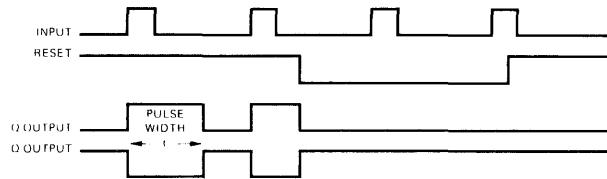

11. V_{CC} and Ground wiring should conform to good high frequency standards so that switching transients on V_{CC} and Ground leads do not cause interaction between one-shots. Use of a 0.01 to 0.1 μ F bypass capacitor between V_{CC} and Ground located near the 9602 is recommended.

FAIRCHILD TTL/MONOSTABLE • 9602

TABLE I – ELECTRICAL CHARACTERISTICS (T_A = -55°C to 125°C, V_{CC} = 5 V ± 10%) (Part No. 9602XM)*

SYMBOL	PARAMETER	LIMITS						UNITS	CONDITIONS (Note 1)	
		-55°C		+25°C			+125°C			
		MIN.	MAX.	MIN.	TYP.	MAX.	MIN.			MAX.
V _{OH}	Output HIGH Voltage	2.4		2.4	3.3		2.4		Volts	V _{CC} = 4.5 V, I _{OH} = -0.96 mA (Note 2)
V _{OL}	Output LOW Voltage		0.4		0.2	0.4		0.4	Volts	V _{CC} = 4.5 V, I _{OL} = 9.92 mA (Note 2) V _{CC} = 5.5 V, I _{OL} = 12.8 mA
V _{IH}	Input HIGH Voltage	2.0		1.7			1.5		Volts	Guaranteed Input HIGH Threshold Voltage
V _{IL}	Input LOW Voltage		0.85		0.90			0.85	Volts	Guaranteed Input LOW Threshold Voltage
I _{IL}	Input LOW Current		-1.6		-1.1	-1.6		-1.6	mA	V _{CC} = 5.5 V, V _{IN} = 0.4 V
			-1.24		-0.97	-1.24		-1.24	mA	V _{CC} = 4.5 V, V _{IN} = 0.4 V
I _{IH}	Input HIGH Current				10	60		60	μA	V _{CC} = 5.5 V, V _{IN} = 4.5 V
I _{SC}	Short Circuit Current					-25			mA	V _{CC} = 5.5 V, V _{OUT} = 1.0 V (Note 2)
I _{PD}	Quiescent Power Supply Drain		45		39	45		45	mA	V _{CC} = 5.0 V
t _{PLH}	Negative Trigger Input to True Output				25	35			ns	V _{CC} = 5.0 V R _X = 5.0 kΩ C _X = 0, C _L = 15 pF
t _{PHL}	Negative Trigger Input to Complement Output				29	43			ns	V _{CC} = 5.0 V R _X = 5.0 kΩ C _X = 0, C _L = 15 pF
t _(min)	Minimum True Output Pulse Width				72	90			ns	V _{CC} = 5.0 V R _X = 5.0 kΩ
	Minimum Complement Output Pulse Width				78	100			ns	C _X = 0, C _L = 15 pF
t	Pulse Width			3.08	3.42	3.76			μs	V _{CC} = 5.0 V, R _X = 10 kΩ, C _X = 1000 pF
C _{STRAY}	Maximum Allowable Wiring Cap. (Pins 2 and 14)		50			50		50	pF	Pins 2 and 14 to Ground
R _X	Timing Resistor	5.0	25	5.0		25	5.0	25	kΩ	

TABLE II – ELECTRICAL CHARACTERISTICS (T_A = 0°C to 75°C, V_{CC} = 5 V ± 5%) (Part No. 9602XC)*

SYMBOL	PARAMETER	LIMITS						UNITS	CONDITIONS (Note 1)	
		0°C		+25°C			+75°C			
		MIN.	MAX.	MIN.	TYP.	MAX.	MIN.			MAX.
V _{OH}	Output HIGH Voltage	2.4		2.4	3.4		2.4		Volts	V _{CC} = 4.75 V, I _{OH} = -0.96 mA (Note 2)
V _{OL}	Output LOW Voltage		0.45		0.2	0.45		0.45	Volts	V _{CC} = 4.75 V, I _{OL} = 11.3 mA (Note 2) V _{CC} = 5.25 V, I _{OL} = 12.8 mA
V _{IH}	Input HIGH Voltage	1.9		1.8			1.65		Volts	Guaranteed Input HIGH Threshold Voltage
V _{IL}	Input LOW Voltage		0.85		0.85			0.85	Volts	Guaranteed Input LOW Threshold Voltage
I _{IL}	Input LOW Current		-1.6		-1.0	-1.6		-1.6	mA	V _{CC} = 5.25 V, V _{IN} = 0.45 V
			-1.41			-1.41		-1.41	mA	V _{CC} = 4.75 V, V _{IN} = 0.45 V
I _{IH}	Input HIGH Current				10	60		60	μA	V _{CC} = 5.25 V, V _{IN} = 4.5 V
I _{SC}	Short Circuit Current					-35			mA	V _{CC} = 5.25 V, V _{OUT} = 1.0 V (Note 2)
I _{PD}	Quiescent Power Supply Drain		52		39	50		52	mA	V _{CC} = 5.0 V, Ground Pins 1 and 2
t _{PLH}	Negative Trigger Input to True Output				25	40			ns	V _{CC} = 5.0 V R _X = 5.0 kΩ C _X = 0, C _L = 15 pF
t _{PHL}	Negative Trigger Input to Complement Output				29	48			ns	V _{CC} = 5.0 V R _X = 5.0 kΩ C _X = 0, C _L = 15 pF
t _(min)	Minimum True Output Pulse Width				72	100			ns	V _{CC} = 5.0 V R _X = 5.0 kΩ
	Minimum Complement Output Pulse Width				78	110			ns	C _X = 0, C _L = 15 pF
t	Pulse Width			3.08	3.42	3.76			μs	V _{CC} = 5.0 V, R _X = 10 kΩ, C _X = 1000 pF
C _{STRAY}	Maximum Allowable Wiring Cap. (Pins 2 and 14)		50			50		50	pF	Pins 2 and 14 to Ground
R _X	Timing Resistor	5.0	50	5.0		50	5.0	50	kΩ	

*X = package type; F for Flatpak, D for Ceramic Dip, P for Plastic Dip. See Packaging Information Section for packages available on this product.

NOTES:

1. Unless otherwise noted, 10 kΩ resistor placed between Pin 2 (14) and V_{CC}, for all tests. (R_X)
2. Ground Pin 1 (15) for V_{OL} on Pin 7 (9), or for V_{OH} on Pin 6 (10), or for I_{SC} on Pin 6 (10); also, apply momentary ground to Pin 4 (12). Open Pin 1 (15) for V_{OL} on Pin 6 (10), or for V_{OH} on Pin 7 (9), or for I_{SC} on Pin 7 (9).

TYPICAL ELECTRICAL CHARACTERISTICS

Fig. 1
INPUT LOAD CURRENT
VERSUS INPUT VOLTAGE

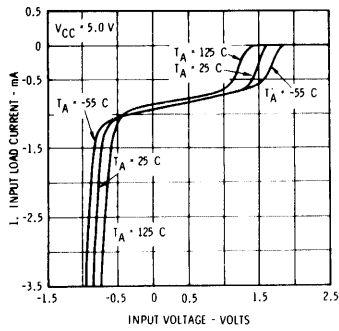

Fig. 2
INPUT LEAKAGE CURRENT
VERSUS INPUT VOLTAGE

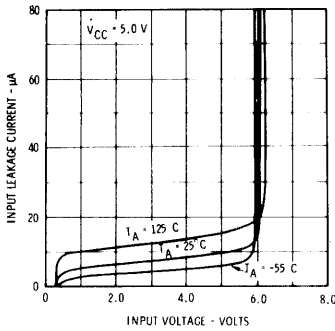

Fig. 3
OUTPUT CURRENT VERSUS
OUTPUT VOLTAGE (LOW STATE)

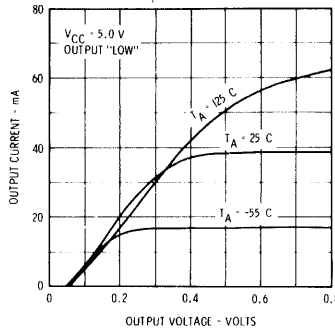

Fig. 4
OUTPUT CURRENT VERSUS
OUTPUT VOLTAGE (HIGH STATE)

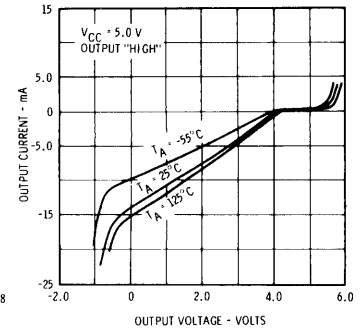

Fig. 5
MINIMUM PULSE WIDTH TO
TRIGGER VERSUS
AMBIENT TEMPERATURE
(POSITIVE EDGE TRIGGER INPUT)

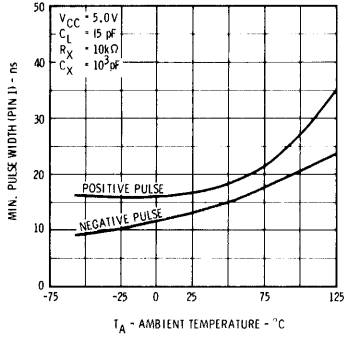

Fig. 6
MINIMUM PULSE WIDTH TO
TRIGGER VERSUS
AMBIENT TEMPERATURE
(NEGATIVE EDGE TRIGGER INPUT)

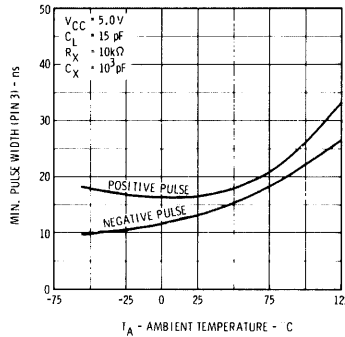

Fig. 7
MINIMUM TIME DELAY,
RESET TO OUTPUT VERSUS
AMBIENT TEMPERATURE

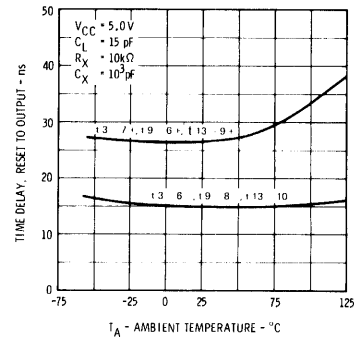

Fig. 8
NORMALIZED OUTPUT
PULSE WIDTH VERSUS
AMBIENT TEMPERATURE

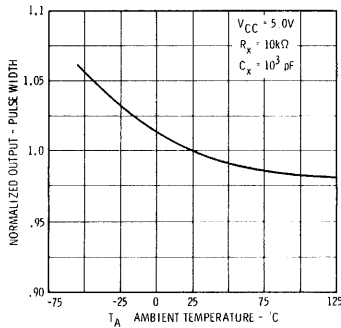

Fig. 9
PULSE WIDTH VERSUS
TIMING RESISTOR

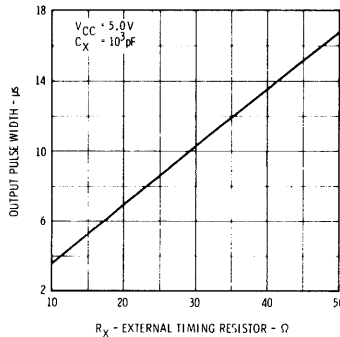

Fig. 10
POWER DISSIPATION VERSUS
AMBIENT TEMPERATURE

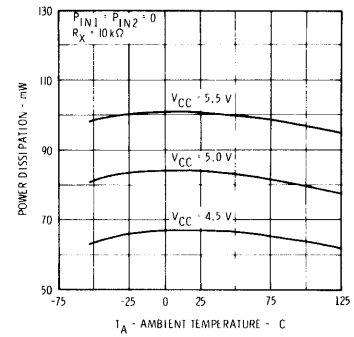

Fig. 11
NORMALIZED OUTPUT
PULSE WIDTH VERSUS
SUPPLY VOLTAGE

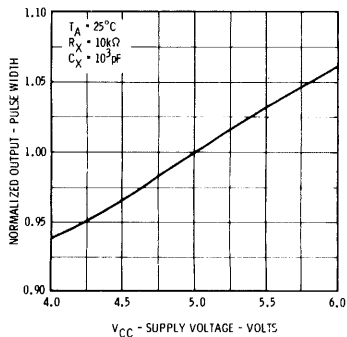

Fig. 12
MINIMUM OUTPUT PULSE
WIDTH VERSUS
AMBIENT TEMPERATURE

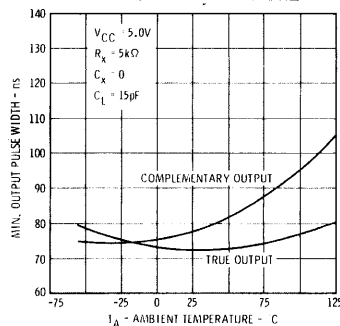
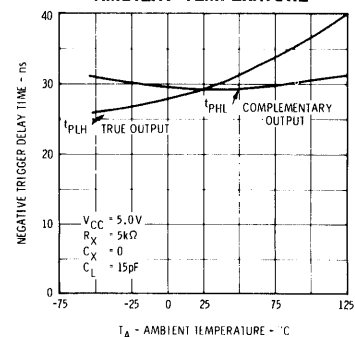

Fig. 13
NEGATIVE TRIGGER DELAY
TIME VERSUS
AMBIENT TEMPERATURE



OUTPUT PULSE WIDTH VERSUS TIMING RESISTANCE AND CAPACITANCE FOR $C_x < 10^3$ pF

For $C_x \geq 10^3$ pF, $t = 0.31 R_x C_x (1 + \frac{1}{R_x})$

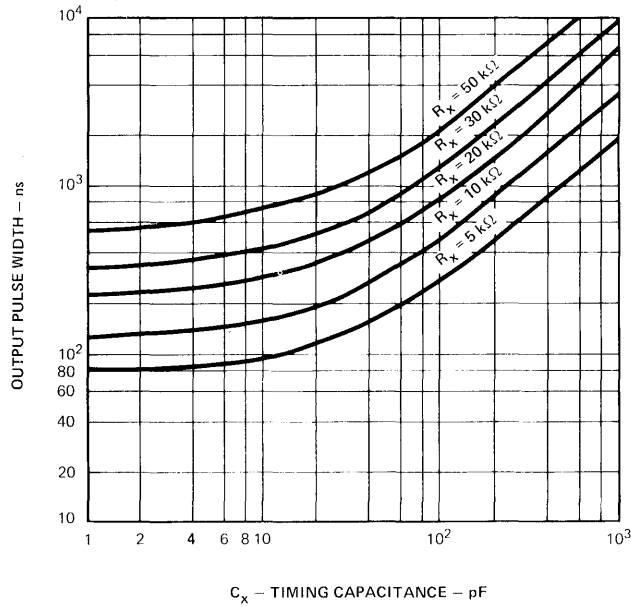

Fig. 14

LOADING RULES

TTL INPUT LOAD AND DRIVE FACTORS

INPUTS	LOAD	
	HIGH	LOW
3, 4, 5, 11, 12, 13	1 U.L.	1 U.L.

OUTPUTS	DRIVE FACTOR	
	HIGH	LOW
6, 7, 9, 10	16 U.L.	8 U.L.

1 Unit Load (U.L.) = 60μA HIGH/1.6mA LOW

TRIGGERING TRUTH TABLE

PIN NO.'S.			Operation
5(11)	4(12)	3(13)	
H→L	L	H	Trigger
H	L→H	H	Trigger
X	X	L	Reset

H = HIGH Voltage Level $\geq V_{IH}$
 L = LOW Voltage Level $\leq V_{IL}$
 X = Don't Care
 H→L = HIGH to LOW Voltage Level transition
 L→H = LOW to HIGH Voltage Level transition

SWITCHING CIRCUITS AND WAVEFORMS

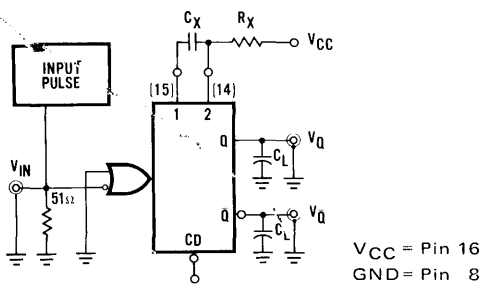

VCC = Pin 16
 GND = Pin 8

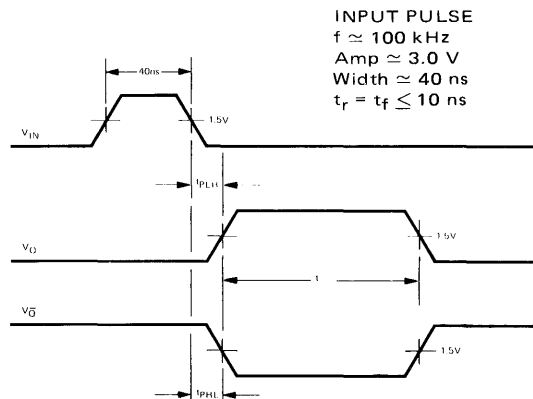

INPUT PULSE
 $f \approx 100$ kHz
 Amp ≈ 3.0 V
 Width ≈ 40 ns
 $t_r = t_f \leq 10$ ns

Fig. 18

LPTTL/MONOSTABLE 96L02

LOW POWER DUAL RETRIGGERABLE RESETTABLE MONOSTABLE MULTIVIBRATOR

DESCRIPTION – The TTL/Monostable 96L02 is a low power Dual Retriggerable, Resettable Monostable Multivibrator which provides an output pulse whose duration and accuracy is a function of external timing components. The 96L02 has excellent immunity to noise on the V_{CC} and ground lines. The 96L02 uses TTL inputs and outputs for high speed and high fan out capability and is compatible with all members of the Fairchild TTL family.

- TYPICAL POWER DISSIPATION OF 25 mW/ONE SHOT
- 50 ns TYPICAL PROPAGATION DELAY
- RETRIGGERABLE 0 TO 100% DUTY CYCLE
- TTL INPUT GATING – LEADING OR TRAILING EDGE TRIGGERING
- COMPLEMENTARY TTL OUTPUTS
- OPTIONAL RETRIGGER LOCK-OUT CAPABILITY
- PULSE WIDTH COMPENSATED FOR V_{CC} AND TEMPERATURE VARIATIONS
- RESETTABLE

PIN NAMES

\bar{B}	Trigger (Active LOW) Input
A	Trigger (Active HIGH) Input
\bar{C}_D	Clear (Active LOW) Input
Q	Output (Active HIGH)
\bar{Q}	Output (Active LOW)

1 Unit Load (U.L.) = 40 μ A HIGH/1.6 mA LOW

LOADING	
HIGH	LOW
0.5	0.25
0.5	0.25
0.5	0.25
9.0	3.0
9.0	3.0

LOGIC DIAGRAM

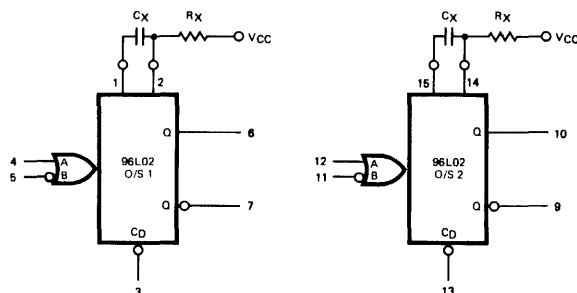

CONNECTION DIAGRAMS DIP (TOP VIEW)

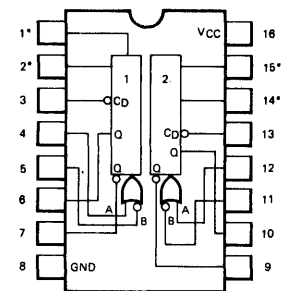

*Pins for external timing.

FLATPAK (TOP VIEW)

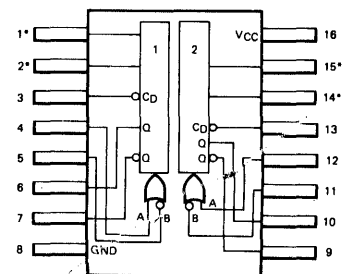

*Pins for external timing.

FUNCTIONAL DESCRIPTION — The 96L02 dual resettable, retriggerable monostable multivibrator has two inputs per function, one active LOW and one active HIGH. This allows leading edge of trailing edge triggering. The TTL inputs make triggering independent of input transition times. When input conditions for triggering are met, a new cycle starts and the external capacitor is rapidly discharged and then allowed to charge. An input cycle time shorter than the output cycle time will retrigger the 96L02 and result in a continuous true output. (See Rule 9) The output pulse may be terminated at any time by connecting the reset pin to a logic level LOW. Active pullups are provided on the outputs for good drive capability into capacitive loads. Retriggering may be inhibited by tying the \bar{Q} output to the active level LOW input or the Q output to the active level HIGH input.

OPERATION RULES

1. An external resistor (R_X) and external capacitor (C_X) are required as shown in the Logic Diagram.
2. The value of R_X may vary from 16 k Ω to 220 k Ω for 0 to 75°C operation. The value of R_X may vary from 20 k Ω to 100 k Ω for -55 to +125°C operation.
3. The value of C_X may vary from 0 to any necessary value available. If, however, the capacitor has leakages approaching 1.0 μ A or if stray capacitance from either terminal to ground is more than 50 pF, the timing equations may not represent the pulse width obtained.
4. The output pulse with (t) is defined as follows:

$$t = 0.33 R_X C_X \left[1 + \frac{3.0}{R_X} \right] \text{ (for } C_X > 10^3 \text{ pF)}$$
 Where R_X is in k Ω , C_X is in pF
 t is in ns
 for $C_X < 10^3$ pF, see Fig. 1

5. If electrolytic type capacitors are to be used, the following three configurations are recommended:

- A. Use with low leakage capacitors:
 The normal RC configuration can be used predictably only if the forward capacitor leakage at 5.0 V is less than 1.0 μ A, and the inverse capacitor leakage at 1.0 V is less than 1.6 μ A over the operational temperature range and Rule 3 above is satisfied.
- B. Use with high inverse leakage current electrolytic capacitors:
 The diode in this configuration prevents high inverse leakage currents through the capacitor by preventing an inverse voltage across the capacitor. The use of this configuration is not recommended with retriggerable operation.

$$t \approx 0.3 RC_X$$

- C. Use to obtain extended pulse widths:
 This configuration can be used to obtain extended pulse widths, because of the larger timing resistor allowed by beta multiplication. Electrolytics with high inverse leakage currents can be used.

$$R < R_X (0.7) (h_{FE} Q_1) \text{ or } < 2.5 \text{ M}\Omega \text{ whichever is the lesser}$$

$$R_X (\text{min}) < R_Y < R_X (\text{max})$$

Q₁: NPN silicon transistor with h_{FE} requirements of above equations, such as 2N5961 or 2N5962

$$t \approx 0.3 RC_X$$

This configuration is not recommended with retriggerable operation.

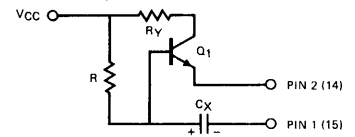
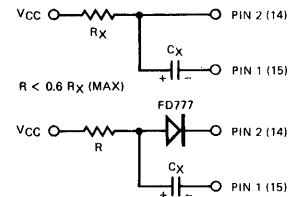

6. To obtain variable pulse width by remote trimming, the following circuit is recommended:

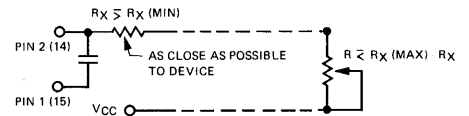

7. Under any operating condition, C_X and R_X (min) must be kept as close to the circuit as possible to minimize stray capacitance and reduce noise pickup.
8. Input Trigger Pulse Rules. See Triggering Truth Table, following pages.

Input to Pin 5 (11)
 Pin 4 (12) = LOW
 Pin 3 (13) = HIGH
 t_1, t_3 = Min. Positive Input Pulse Width > 60 ns
 t_2, t_4 = Min. Negative Input Pulse Width > 60 ns

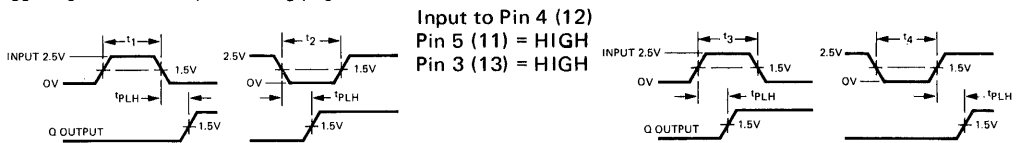

9. The retriggerable pulse width is calculated as shown below:

$$t_w = t + t_{PLH} = 0.33 R_X C_X \left(1 + \frac{3.0}{R_X} \right) + t_{PLH}$$

The retrigger pulse width is equal to the pulse width (t) plus a delay time. For pulse widths greater than 500 ns, t_w can be approximated as t. Retriggering will not occur if the retrigger pulse comes within $\approx 0.9 C_X$ ns after the initial trigger pulse. (i.e., during the discharge cycle)

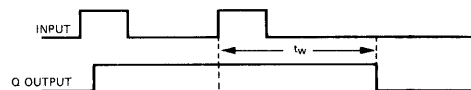

10. Reset Operation — An overriding active LOW level is provided on each oneshot. By applying a LOW to the reset, any timing cycle can be terminated or any new cycle inhibited until the LOW reset input is removed. Trigger inputs will not produce spikes in the output when the reset is held LOW.

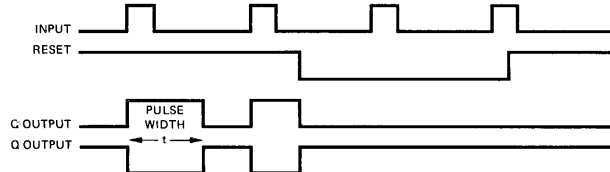

11. V_{CC} and Ground wiring should conform to good high frequency standards so that switching transients on V_{CC} and Ground leads do not cause interaction between one-shots. Use of a 0.01 to 0.1 μ F bypass capacitor between V_{CC} and Ground located near the 96L02 is recommended.

FAIRCHILD LPTTL/MONOSTABLE • 96L02

ABSOLUTE MAXIMUM RATINGS (above which the useful life may be impaired)

Storage Temperature	-65°C to +150°C
Temperature (Ambient) Under Bias	-55°C to +125°C
V _{CC} Pin Potential to Ground Pin	-0.5 V to +7.0 V
*Input Voltage (dc)	-0.5 V to +5.5 V
*Input Current (dc)	-30 mA to +5.0 mA
Voltage Applied to Outputs (Output HIGH)	-0.5 V to +V _{CC} value
Output Current (dc) (Output LOW)	+30 mA

*Either Input Voltage Limit or Input Current is sufficient to protect the inputs.

GUARANTEED OPERATING RANGES

PART NUMBER	SUPPLY VOLTAGE (V _{CC})			TEMPERATURE
	MIN.	TYP.	MAX.	
96L02XM	4.5 V	5.0 V	5.5 V	-55°C to 125°C
96L02XC	4.75 V	5.0 V	5.25 V	0°C to 75°C

X = package type; F for Flatpak, D for Ceramic Dip, P for Plastic Dip. See Packaging Information Section for packages available on this product.

ELECTRICAL CHARACTERISTICS OVER OPERATING TEMPERATURE RANGE (Unless otherwise noted)

SYMBOL	CHARACTERISTIC	LIMITS			UNITS	CONDITIONS
		MIN.	TYP. (Note 4)	MAX.		
V _{IH}	Input HIGH Voltage	2.0			Volts	Guaranteed Input HIGH Threshold Voltage For all Inputs
V _{IL}	Input LOW Voltage			0.7	Volts	Guaranteed Input LOW Threshold Voltage For all Inputs
V _{OH}	Output HIGH Voltage	2.4	3.4		Volts	V _{CC} = MIN., I _{OH} = -0.36 mA
V _{OL}	Output LOW Voltage		0.14	0.3	Volts	V _{CC} = MIN., I _{OL} = 4.80 mA
I _{IH}	Input HIGH Current			20	μA	V _{CC} = MAX., V _{IN} = 2.4 V
				1.0	mA	V _{CC} = MAX., V _{IN} = 5.5 V
I _{IL}	Input LOW Current		-0.25	-0.4	mA	V _{CC} = MAX., V _{IN} = 0.3 V
I _{SC} (I _{OS})	Output Short Circuit Current (Note 5)	-2.0		-13	mA	V _{CC} = MAX., V _{OUT} = 1.0 V
I _{CC}	Power Supply Current		10	16	mA	V _{CC} = MAX.

NOTES:

1. The actual testing procedures used to guarantee the Electrical Characteristics are contained in a detailed Customer Sample Specification. A copy of this specification can be obtained from Fairchild Digital Product Marketing, Mountain View, California.
2. Conditions for testing, not shown in the table, are chosen to guarantee operation under "worst case" conditions.
3. The specified LIMITS represent the "worst case" value for the parameter. Since these "worst case" values normally occur at the temperature and supply voltages extremes, additional noise immunity and guard banding can be achieved by decreasing the allowable system operating ranges.
4. Typical limits are at V_{CC} = 5.0 V, 25°C, and maximum loading.
5. Not more than one output should be shorted at a time.

FAIRCHILD LPTTL/MONOSTABLE • 96L02

SWITCHING CHARACTERISTICS ($T_A = 25^\circ\text{C}$)

SYMBOL	PARAMETER	LIMITS			UNITS	CONDITIONS
		MIN.	TYP.	MAX.		
96L02XM						
t _{PLH}	Negative Trigger Input to True Output		55	75	ns	V _{CC} = 5.0 V, R _X = 20 kΩ C _X = 0, C _L = 15 pF
t _{PHL}	Negative Trigger Input to Complement Output		45	62	ns	V _{CC} = 5.0 V, R _X = 20 kΩ C _X = 0, C _L = 15 pF
t(min)	Minimum True Output Pulse Width		110		ns	V _{CC} = 5.0 V, R _X = 20 kΩ C _X = 0, C _L = 15 pF
t	Pulse Width	12.4	13.8	15.2	μs	V _{CC} = 5.0 V, R _X = 39 kΩ, C _X = 1000 pF
R _X	Timing Resistor Range	20		100	kΩ	
Δt	Maximum Change in True Output Pulse Width over Temperature Range		1.3		%	R _X = 39 kΩ, C _X = 1000 pF

96L02XC						
t _{PLH}	Negative Trigger Input to True Output		55	80	ns	V _{CC} = 5.0 V, R _X = 20 kΩ C _X = 0, C _L = 15 pF
t _{PHL}	Negative Trigger Input to Complement Output		45	65	ns	V _{CC} = 5.0 V, R _X = 20 kΩ C _X = 0, C _L = 15 pF
t(min)	Minimum True Output Pulse Width		110		ns	V _{CC} = 5.0 V, R _X = 20 kΩ C _X = 0, C _L = 15 pF
t	Pulse Width	12.4	13.8	15.2	μs	V _{CC} = 5.0 V, R _X = 39 kΩ, C _X = 1000 pF
R _X	Timing Resistor Range	16		220	kΩ	
Δt	Maximum Change in True Output Pulse Width over Temperature Range		0.3	1.6	%	R _X = 39 kΩ, C _X = 1000 pF

OUTPUT PULSE WIDTH (t) USING LOW VALUES OF C_X (C_X ≤ 1000 pF)
(FOR C_X > 1000 pF SEE OPERATION RULES 4 AND 5.)

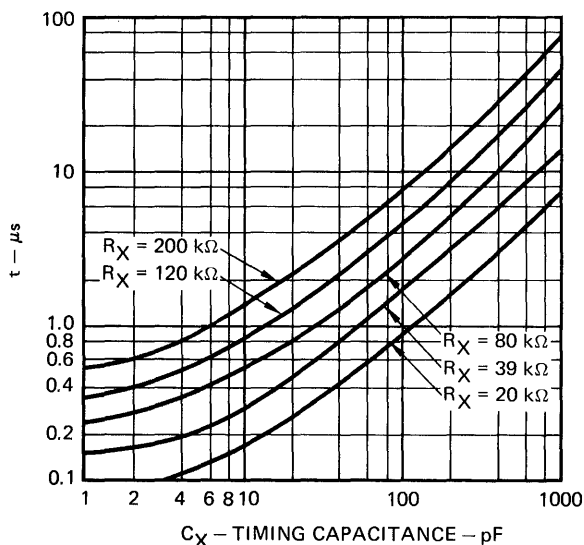
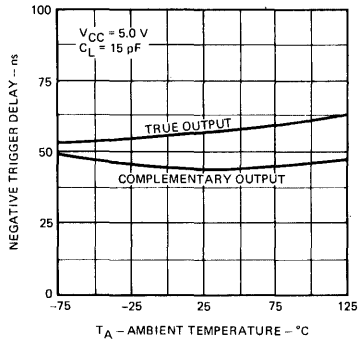

Fig. 1

TYPICAL PULSE CHARACTERISTICS

NEGATIVE TRIGGER DELAY TIME VERSUS AMBIENT TEMPERATURE



NORMALIZED OUTPUT PULSE WIDTH VERSUS OPERATING DUTY CYCLE

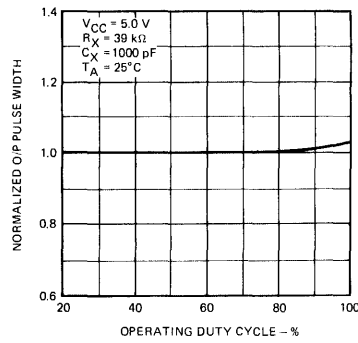

NORMALIZED OUTPUT PULSE WIDTH VERSUS SUPPLY VOLTAGE

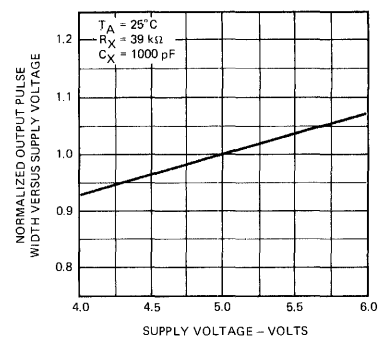

MIN. OUTPUT PULSE WIDTH VERSUS AMBIENT TEMPERATURE

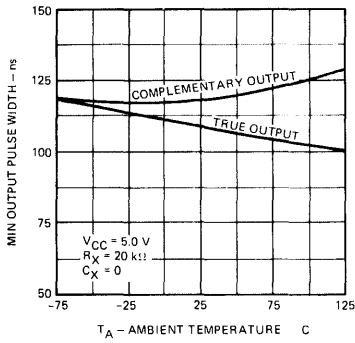

NORMALIZED OUTPUT PULSE WIDTH VERSUS AMBIENT TEMPERATURE

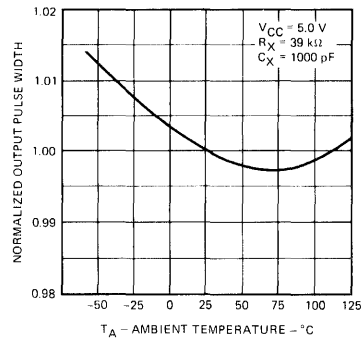

TRIGGERING TRUTH TABLE

PIN NO.'S.			Operation
5(11)	4(12)	3(13)	
H→L	L	H	Trigger
H	L→H	H	Trigger
X	X	L	Reset

H = HIGH Voltage Level $\geq V_{IH}$
 L = LOW Voltage Level $\leq V_{IL}$
 X = Don't Care (either H or L)
 H→L = HIGH to LOW Voltage Level transition
 L→H = LOW to HIGH Voltage Level transition

SWITCHING CIRCUITS AND WAVEFORMS

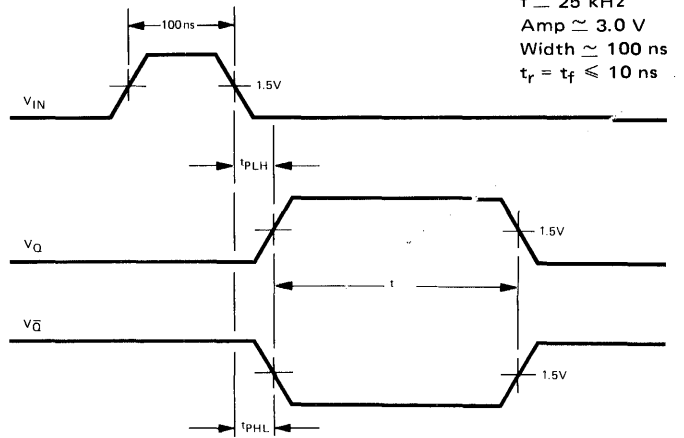
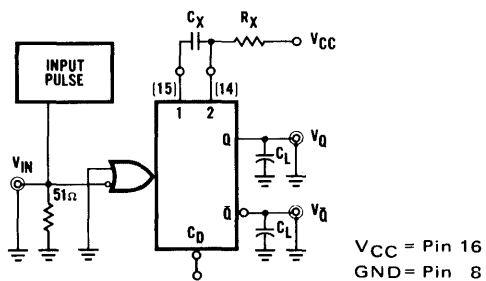

TTL/MONOSTABLE 9603/54121, 74121

MONOSTABLE MULTIVIBRATOR

DESCRIPTION — The 9603/54121, 74121 is a TTL Monostable Multivibrator with dc triggering from positive or gated negative going inputs and with inhibit facility. Both positive and negative going output pulses are provided with full fan out to 10 normalized loads.

Pulse triggering occurs at a particular voltage level and is not directly related to the transition time of the input pulse. Schmitt-trigger input circuitry for the B input allows jitter-free triggering from inputs with transition times as slow as 1.0 V/S, providing the circuit with an excellent noise immunity of typically 1.2 V. A high immunity to V_{CC} noise of typically 1.5 V is also provided by internal latching circuitry.

Once fired, the outputs are independent of further transitions on the inputs and are a function only of the timing components. Input pulses may be of any duration relative to the output pulse. Output pulse lengths may be varied from 40 ns to 40 s by choosing appropriate timing components. With no external timing components (i.e., pin 9 connected to pin 14, pins 10, 11 open) an output pulse of typically 30 ns is achieved which may be used as a dc triggered reset signal. Output rise and fall times are TTL compatible and independent of pulse length.

Pulse width is achieved through internal compensation and is virtually independent of V_{CC} and temperature. In most applications, pulse stability will only be limited by the accuracy of external timing components.

Jitter-free operation is maintained over the full temperature and V_{CC} range for more than six decades of timing capacitance (10 pF to 10 μ F) and more than one decade of timing resistance (2 k Ω to 40 k Ω). Throughout these ranges, pulse width is defined by the relationship $t_p(\text{out}) = C_T R_T \log_e 2$.

Circuit performance is achieved with a nominal power dissipation of 90 mW at 5.0 V (50% duty cycle) and a quiescent dissipation of typically 65 mW.

Duty cycles as high as 90% are achieved when using $R_T = 40$ k Ω . Higher duty cycles are achievable if a certain amount of pulse-width jitter is allowed.

LOGIC AND CONNECTION DIAGRAM

DIP (TOP VIEW)

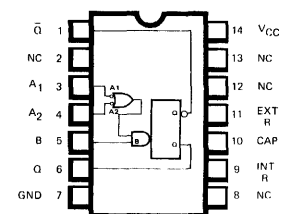

Note: 9–11 Timing Pins

FLATPAK (TOP VIEW)

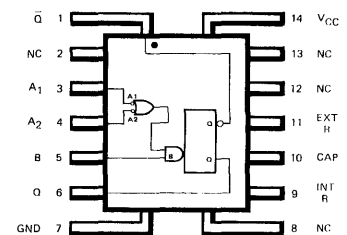

Note: 9–11 Timing Pins

(See Notes 6 thru 9)

TRUTH TABLE (See Notes 1 thru 3)

t_n INPUT			t_{n+1} INPUT			OUTPUT
A ₁	A ₂	B	A ₁	A ₂	B	
H	H	L	H	H	H	Inhibit
L	X	H	L	X	L	Inhibit
X	L	H	X	L	L	Inhibit
L	X	L	L	X	H	One Shot
X	L	L	X	L	H	One Shot
H	H	H	X	L	H	One Shot
H	H	H	L	X	H	One Shot
X	L	L	X	H	L	Inhibit
L	X	L	H	X	L	Inhibit
X	L	H	H	H	H	Inhibit
L	X	H	H	H	H	Inhibit
H	H	L	X	L	L	Inhibit
H	H	L	L	X	L	Inhibit

H = $V_{IH} \geq 2$ V
L = $V_{IL} \leq 0.8$ V

NOTES:

- t_n = time before input transition.
- t_{n+1} = time after input transition.
- X indicates that either a HIGH or LOW, may be present.
- NC = No Internal Connection.
- A₁ and A₂ are negative edge triggered-logic inputs, and will trigger the one shot when either or both go to LOW level with B at HIGH level.
- B is a positive Schmitt-trigger input for slow edges or level detection and will trigger the one shot when B goes to HIGH level with either A₁ or A₂ at LOW level. (See Truth Table.)
- External timing capacitor may be connected between pin 10 (positive) and pin 11. With no external capacitance, an output pulse width of typically 30 ns is obtained.
- To use the internal timing resistor (2 k Ω nominal), connect pin 9 to pin 14.
- To obtain variable pulse width connect external variable resistance between pin 9 and pin 14. No external current limiting is needed.
- For accurate repeatable pulse widths connect an external resistor between pin 11 and pin 14 with pin 9 open-circuit.

Positive logic: See truth table and notes 5 and 6

TTL/MONOSTABLE • 9603/54121, 74121

ABSOLUTE MAXIMUM RATINGS (above which the useful life may be impaired)

Storage Temperature	-65°C to +150°C
Temperature (Ambient) Under Bias	-55°C to +125°C
V _{CC} Pin Potential to Ground Pin	-0.5 V to +7.0 V
*Input Voltage (dc)	-0.5 V to +5.5 V
*Input Current (dc)	-30 mA to +5.0 mA
Voltage Applied to Outputs (Output HIGH)	-0.5 V to +V _{CC} value
Output Current (dc) (Output LOW)	+30 mA

*Either Input Voltage limit or Input Current limit is sufficient to protect the inputs.

RECOMMENDED OPERATING CONDITIONS

PARAMETER	9603XM/54121XM			9603XC/74121XC			UNITS
	MIN.	TYP.	MAX.	MIN.	TYP.	MAX.	
Supply Voltage V _{CC}	4.5	5.0	5.5	4.75	5.0	5.25	Volts
Operating Free-Air Temperature Range	-55	25	125	0	25	70	°C
Normalized Fan Out from Each Output, N			10			10	U.L.
Input Pulse Rise/Fall Time:	Schmitt Input (B)		1.0			1.0	V/s
	Logic Inputs (A ₁ , A ₂)		1.0			1.0	V/μs
Input Pulse Width	50			50			ns
External Timing Resistance Between Pins 11 and 14 (Pin 9 open)	1.4			1.4			kΩ
External Timing Resistance			30			40	kΩ
Timing Capacitance	0		1000	0		1000	μF
Output Pulse Width			40			40	s
Duty Cycle: R _T =	2 kΩ		67%			67%	
	30 kΩ		90%				
	40 kΩ					90%	

X= package type; F for Flatpak, D for Ceramic Dip, P for Plastic Dip. See Packaging Information Section for packages available on this product.

ELECTRICAL CHARACTERISTICS OVER OPERATING TEMPERATURE RANGE (Unless Otherwise Noted)

SYMBOL	PARAMETER	LIMITS			UNITS	TEST CONDITIONS (Note 1)	TEST* FIGURE	
		MIN.	TYP. (Note 2)	MAX.				
V _{T+}	Positive-Going Threshold Voltage at A Input		1.4	2.0	Volts	V _{CC} = MIN.	57	
V _{T-}	Negative-Going Threshold Voltage at A Input	0.8	1.4		Volts	V _{CC} = MIN.	57	
V _{T+}	Positive-Going Threshold Voltage at B Input		1.55	2.0	Volts	V _{CC} = MIN.	57	
V _{T-}	Negative-Going Threshold Voltage at B Input	0.8	1.35		Volts	V _{CC} = MIN.	57	
V _{OH}	Output HIGH Voltage	2.4	3.3		Volts	V _{CC} = MIN., I _{OH} = -0.4 mA	57	
V _{OL}	Output LOW Voltage		0.22	0.4	Volts	V _{CC} = MIN., I _{OL} = 16 mA	57	
I _{IH}	Input HIGH Current	at A ₁ or A ₂		2.0	40	μA	V _{CC} = MAX., V _{IN} = 2.4 V	60
				0.05	1.0	mA	V _{CC} = MAX., V _{IN} = 5.5 V	
		at B		4.0	80	μA	V _{CC} = MAX., V _{IN} = 2.4 V	61
				0.05	1.0	mA	V _{CC} = MAX., V _{IN} = 5.5 V	
I _{IL}	Input LOW Current	at A ₁ or A ₂		-1.0	-1.6	mA	V _{CC} = MAX., V _{IN} = 0.4 V	58
		at B		-2.0	-3.2	mA	V _{CC} = MAX., V _{IN} = 0.4 V	59
I _{OS}	Output Short Circuit Current at Q or Q (Note 3)		-20	-25	-55	mA	9603/54121	62 & 63
			-18	-25	-55	mA	9603/74121	
I _{CC}	Supply Current	in Quiescent (Unfired) State		13	25	mA	V _{CC} = MAX.	64
		in Fired State		23	40	mA	V _{CC} = MAX.	64

NOTES:

- (1) For conditions shown as MIN. or MAX., use the appropriate value specified under recommended operating conditions for the applicable device type.
- (2) Typical limits are at V_{CC} = 5.0 V, 25°C.
- (3) Not more than one output should be shorted at a time.

*See parameter measurement information in series 9N/54, 74TTL section.

SWITCHING CHARACTERISTICS ($T_A = 25^\circ\text{C}$)

SYMBOL	PARAMETER	LIMITS			UNITS	TEST CONDITIONS	TEST * FIGURE	
		MIN.	TYP.	MAX.				
t _{PLH}	Turn Off Delay B Input to Q Output	15	35	55	ns	V _{CC} = 5.0 V C _L = 15 pF C _T = 80 pF	H	
t _{PLH}	Turn Off Delay A ₁ /A ₂ Inputs to Q Output	25	45	70				
t _{PHL}	Turn On Delay B Input to \bar{Q} Output	20	40	65				
t _{PHL}	Turn On Delay A ₁ /A ₂ Inputs to \bar{Q} Output	30	50	80				
t _{pw(out)}	Pulse Width Obtained Using Internal Timing Resistor	70	110	150	ns	C _T = 80 pF	V _{CC} = 5.0 V C _L = 15 pF R _T = Open Pin 9 to V _{CC}	I
t _{pw(out)}	Pulse Width Obtained with Zero Timing Capacitance	20	30	50	ns	C _T = 0 pF		
t _{pw(out)}	Pulse Width Obtained Using External Timing Resistor	600	700	800	ns	C _T = 100 pF	V _{CC} = 5.0 V C _L = 15 pF R _T = 10 kΩ Pin 9 to Open	I
		6.0	7.0	8.0	ms	C _T = 1.0 μF		
t _{hold}	Minimum Duration of Trigger Pulse		30	50	ns	C _T = 80 pF	V _{CC} = 5.0 V C _L = 15 pF R _T = Open Pin 9 to V _{CC}	

*See parameter measurement information in series 9N/54, 74 section.

TYPICAL CHARACTERISTICS

Fig. 1
VARIATION IN INTERNAL TIMING RESISTOR VALUE VERSUS AMBIENT TEMPERATURE

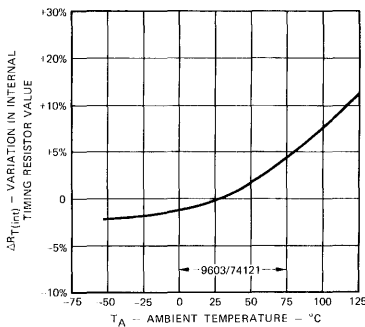

Fig. 2
VARIATION IN OUTPUT PULSE WIDTH VERSUS SUPPLY VOLTAGE

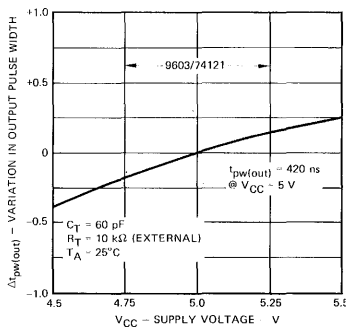

Fig. 3
VARIATION IN OUTPUT PULSE WIDTH VERSUS AMBIENT TEMPERATURE

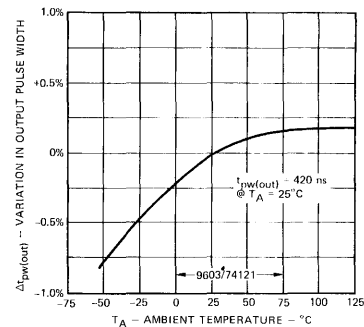

Fig. 4
SCHMITT TRIGGER THRESHOLD VOLTAGE VERSUS AMBIENT TEMPERATURE

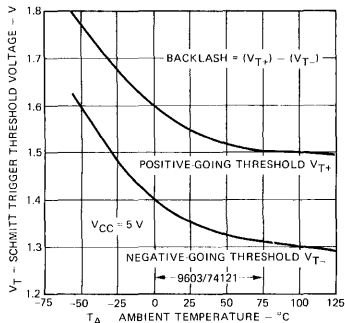

Fig. 5
TURN OFF DELAY TIME B INPUT TO Q OUTPUT VERSUS AMBIENT TEMPERATURE

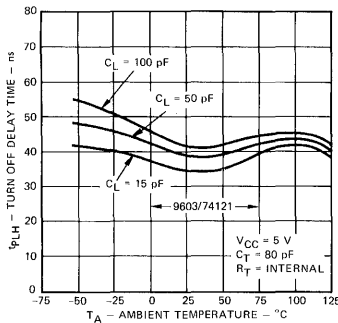
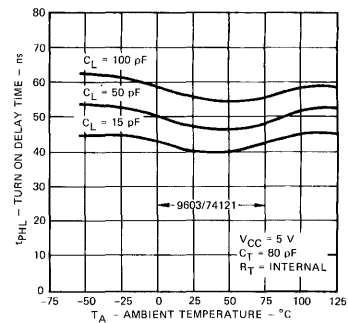

Fig. 6
TURN ON DELAY TIME B INPUT TO Q OUTPUT VERSUS AMBIENT TEMPERATURE



TYPICAL CHARACTERISTICS (Cont'd)

Fig. 7
OUTPUT PULSE WIDTH
VERSUS
TIMING RESISTOR VALUE

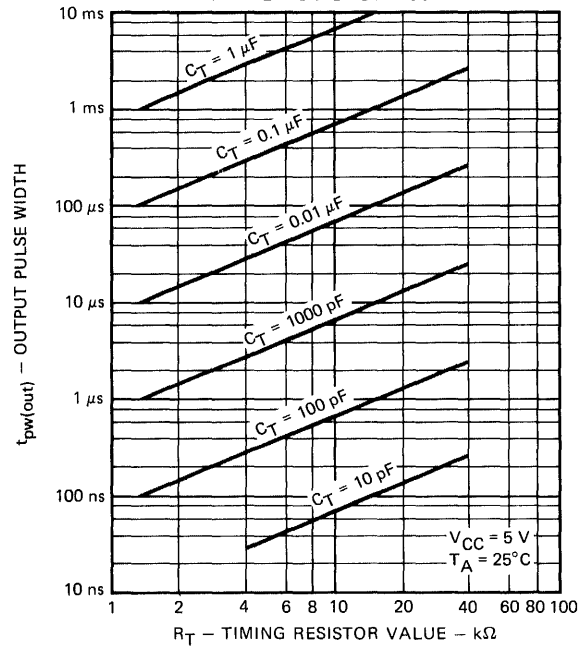
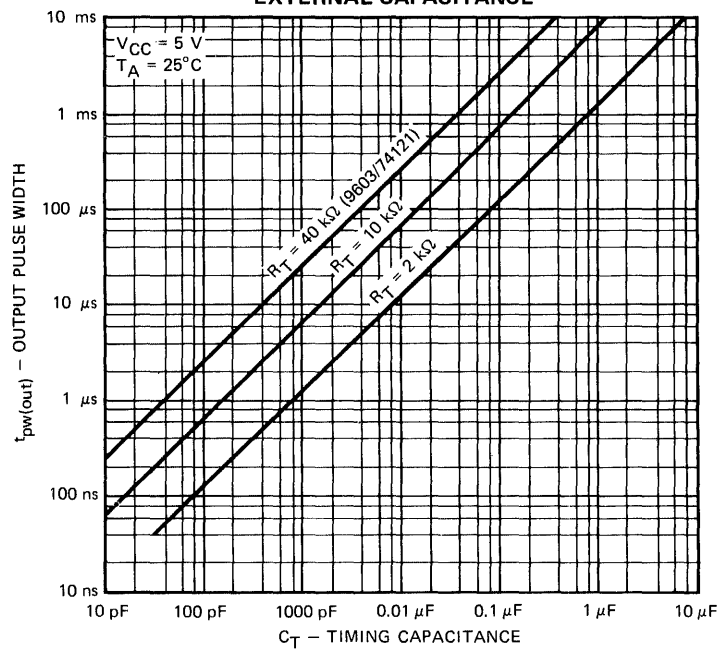

Fig. 8
OUTPUT PULSE WIDTH
VERSUS
EXTERNAL CAPACITANCE



μA9614

DUAL DIFFERENTIAL LINE DRIVER

FAIRCHILD LINEAR INTEGRATED CIRCUIT

GENERAL DESCRIPTION — The μA9614 is a TTL compatible Dual Differential Line Driver. It is designed to drive transmission lines either differentially or single-ended, back-matched or terminated. The outputs are similar to TTL, with the active pull-up and the pull-down split and brought out to adjacent pins. This allows multiplex operation (Wired-OR) at the driving site in either the single-ended mode via the uncommitted collector, or in the differential mode by use of the active pull-ups on one side and the uncommitted collectors on the other (See Fig. 5). The active pull-up is short circuit protected and offers a low output impedance to allow back-matching. The two pairs of outputs are complementary providing "NAND" and "AND" functions of the inputs, adding greater flexibility. The input and output levels are TTL compatible with clamp diodes provided at both input and output to handle line transients.

- SINGLE 5 VOLT SUPPLY
- TTL COMPATIBLE INPUTS
- OUTPUT SHORT CIRCUIT PROTECTION
- INPUT CLAMP DIODES
- OUTPUT CLAMP DIODES FOR TERMINATION OF LINE TRANSIENTS
- COMPLIMENTARY OUTPUTS FOR 'NAND', 'AND' OPERATION
- UNCOMMITTED COLLECTOR OUTPUTS FOR WIRED-OR APPLICATION
- MILITARY TEMPERATURE RANGE

ABSOLUTE MAXIMUM RATINGS (above which the useful life may be impaired)

Storage Temperature	-65°C to +150°C
Temperature (Ambient) Under Bias	-55°C to +125°C
V _{CC} Pin Potential to Ground Pin	-0.7 V to +7.0 V
Input Voltage	-0.5 V to +5.5 V
Voltage Supplied to Outputs (Open Collector)	-0.5 V to +12 V
Lead Temperature (Soldering, 60 seconds)	300°C
Internal Power Dissipation (Note 1)	
Ceramic DIP	730 mW
Flatpak	570 mW

NOTE

1. Rating applies to ambient temperatures up to 70°C. Above 70°C derate linearly at 8.3 mW/°C for the Ceramic DIP and 7.1 mW/°C for the Flatpak.

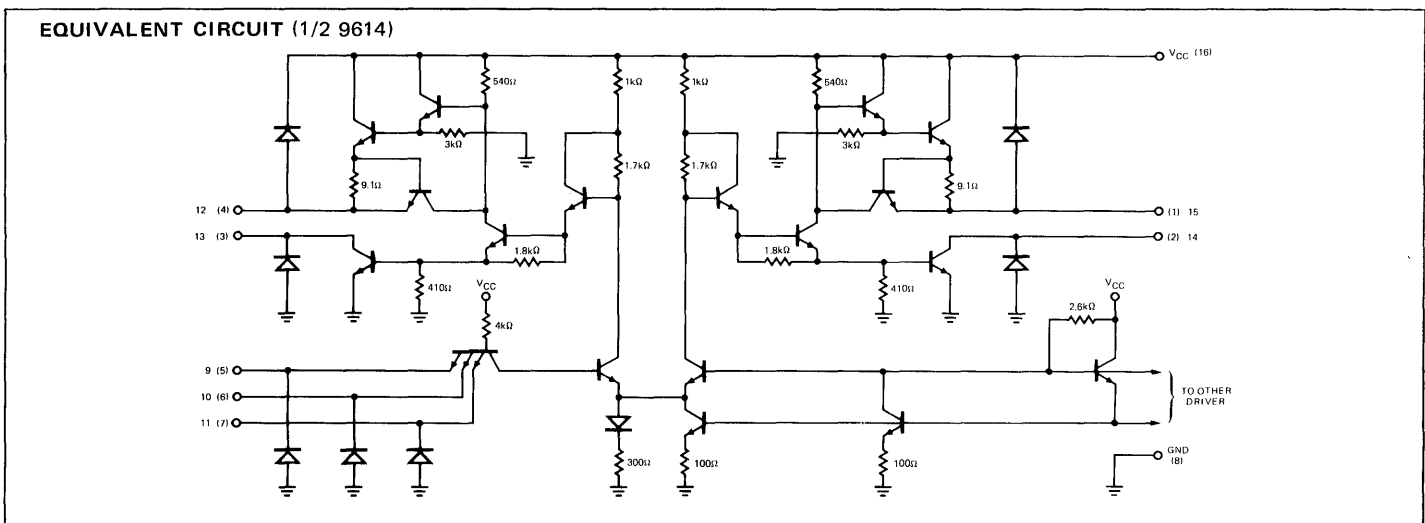
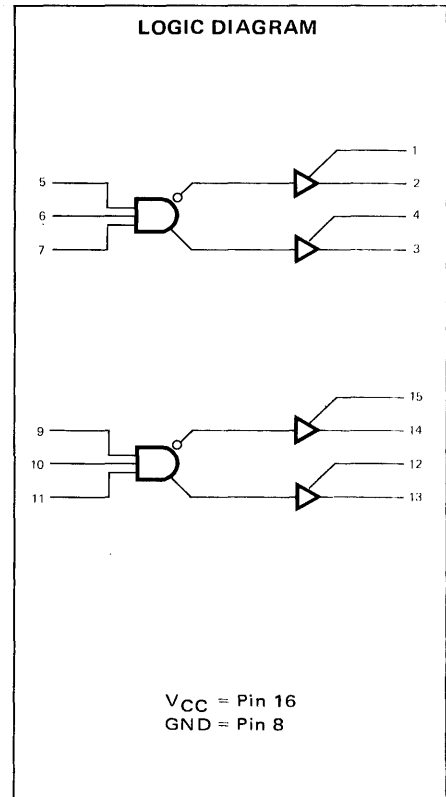

μA9615

DUAL DIFFERENTIAL LINE RECEIVER

FAIRCHILD LINEAR INTEGRATED CIRCUITS

GENERAL DESCRIPTION — The μA9615 is a Dual Differential Line Receiver designed to receive differential digital data from transmission lines and operate over the military and industrial temperature ranges using a single 5 V supply. It can receive ±500 mV of differential data in the presence of high level (±15 V) common mode voltages and deliver undisturbed TTL logic to the output.

The response time can be controlled by use of an external capacitor. A strobe and a 130 Ω terminating resistor are provided at the inputs. The output has an uncommitted collector with an active pull-up available on an adjacent pin to allow either "wire-or" or active pull up TTL output configuration.

- TTL COMPATIBLE OUTPUT
- HIGH COMMON MODE VOLTAGE RANGE
- CHOICE OF AN UNCOMMITTED COLLECTOR OR ACTIVE PULL-UP
- STROBE
- FULL MILITARY TEMPERATURE RANGE
- SINGLE 5 V SUPPLY VOLTAGES
- FREQUENCY RESPONSE CONTROL
- 130 Ω TERMINATING RESISTOR

ABSOLUTE MAXIMUM RATINGS (above which the useful life may be impaired)

Storage Temperature	-65°C to +150°C
Temperature (Ambient) Under Bias	-55°C to +125°C
VCC1 Pin Potential to Ground Pin	-0.5 V to +7.0 V
Input Voltage Referred to Ground (Pins 5, 6, 7, 9, 10, 11)	±20 V
Voltage Applied to Outputs for HIGH Output State without Active Pull Up	-0.5 V to +13.2 V
Voltage Applied to Strobe	-0.5 V to +5.5 V
Lead Temperature (Soldering, 60 seconds)	300°C
Internal Power Dissipation (Note 1)	
Ceramic DIP	730 mW
Flatpak	570 mW

NOTE

1. Rating applies to ambient temperatures up to 70°C. Above 70°C derate linearly at 8.3 mW/°C for the Ceramic DIP and 7.1 mW/°C for the Flatpak Package.

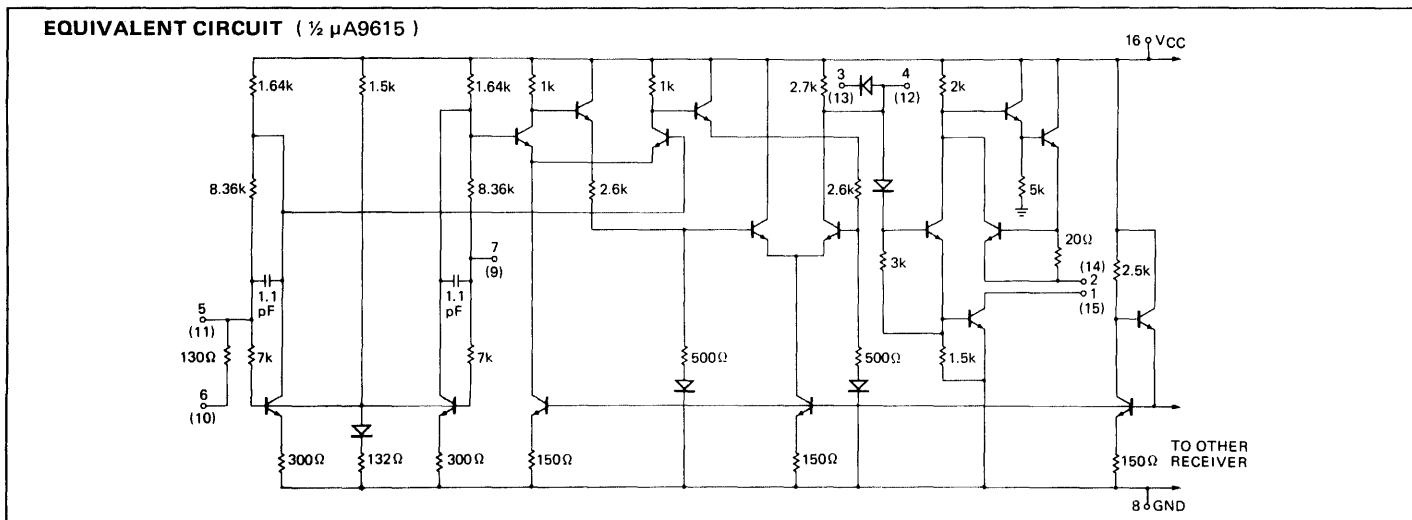
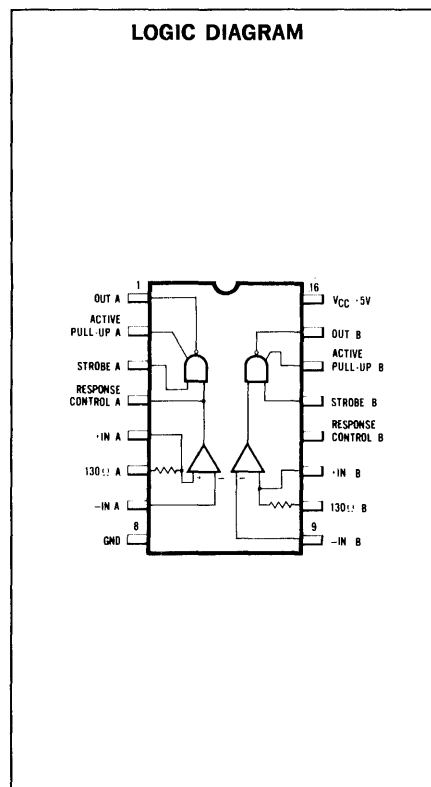

μA9616

TRIPLE EIA RS-232-C LINE DRIVER

FAIRCHILD LINEAR INTEGRATED CIRCUITS

GENERAL DESCRIPTION — The μA9616 is a Triple Line Driver which meets the electrical interface specifications of EIA RS-232-C and CCITT V.24. Each driver in the μA9616 converts TTL/DTL logic level to EIA/CCITT levels for transmission between data terminal equipment and data communication equipment. The μA9617 performs the complementary functions. The output slew rate is internally limited and can be lowered by an external capacitor; all output currents are short circuit limited. The outputs are protected against RS-232-C fault conditions. A logic HIGH level on the inhibit terminal interrupts signal transfer and forces the output to a $-V_{OUT}$ or MARK state. The μA9616 is constructed on a single silicon chip using the Fairchild Planar* process.

- INTERNAL SLEW RATE LIMITING
- NO EXTERNAL CAPACITORS REQUIRED
- THREE CHANNELS PER PACKAGE
- MEETS EIA RS-232-C AND CCITT V.24 SPECIFICATIONS
- LOGICAL TRUE INHIBIT FUNCTION
- SUPPLY INDEPENDENT OUTPUT SWING
- OUTPUT CURRENT LIMITING

ABSOLUTE MAXIMUM RATINGS

Supply Voltage	±15 V
Input or Inhibit Voltage	-1.5 to +6 V
Output Signal Voltage	±15 V
Maximum Power Dissipation (Note 1)	630 mW
Storage Temperature Range	-65°C to +150°C
Operating Temperature	0°C to +75°C
Lead Temperature (Soldering, 60 seconds)	300°C

Note 1: Perate 8.3mW/°C above 70°C

CONNECTION DIAGRAM (TOP VIEW)

TRUTH TABLE

INPUT		INHIBIT		OUTPUT	
1	2	3	6	4	10
All Sections:					
L	L	L	L	L	H
H	H	L	L	L	L
L	L	H	H	L	L
H	H	H	H	L	L
For Channels A & B add:					
L	H	L	L	H	H
H	L	L	L	H	H
L	H	H	H	L	L
H	L	H	H	L	L

(For Channel C, omit INPUT 2 Column)

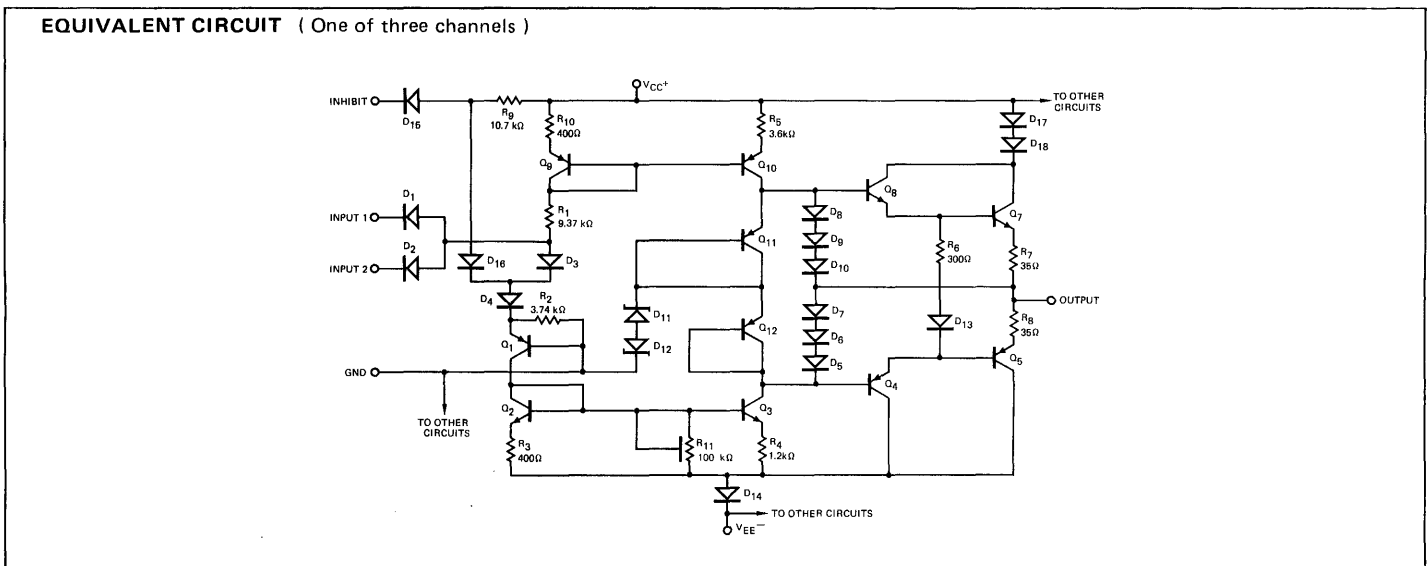

*Planar is a patented Fairchild process.

μA9617

TRIPLE EIA RS-232-C LINE RECEIVER

FAIRCHILD LINEAR INTEGRATED CIRCUITS

GENERAL DESCRIPTION — The μA9617 is a Triple Line Receiver designed to meet the terminator electrical requirements of EIA RS-232-C AND CCITT V.24. It receives line signals produced by the μA9616, an EIA/CCITT driver, and converts them to TTL compatible logic levels. The inputs have a resistance between 3 kΩ and 7 kΩ and can withstand ±25 V. Each receiver can operate in either hysteresis or non-hysteresis (slicing) modes, and each receiver provides fail-safe operation as defined by Section 2.5 of RS-232-C. Noise immunity may be increased by connecting a capacitor between the response control pin and ground. The μA9617 is constructed on a single silicon chip using the Fairchild Planar* process.

- MEETS ALL EIA RS-232-C AND CCITT V.24 SPECIFICATIONS
- FAIL-SAFE OPERATION
- HYSTERESIS OR NON-HYSTERESIS MODE
- INDIVIDUAL RESPONSE CONTROLS
- TTL COMPATIBLE OUTPUT
- SINGLE +5 V SUPPLY

ABSOLUTE MAXIMUM RATINGS

Supply Voltage	7 V
Input Voltage	±25V
Output Current	25 mA
Maximum Power Dissipation (Note 1)	630mW
Storage Temperature Range	-65°C to +150°C
Operating Temperature Range	0°C to +75°C
Lead Temperature (Soldering, 60 seconds)	300°C

Note 1. Derate 8.3 mW/°C above 70°C

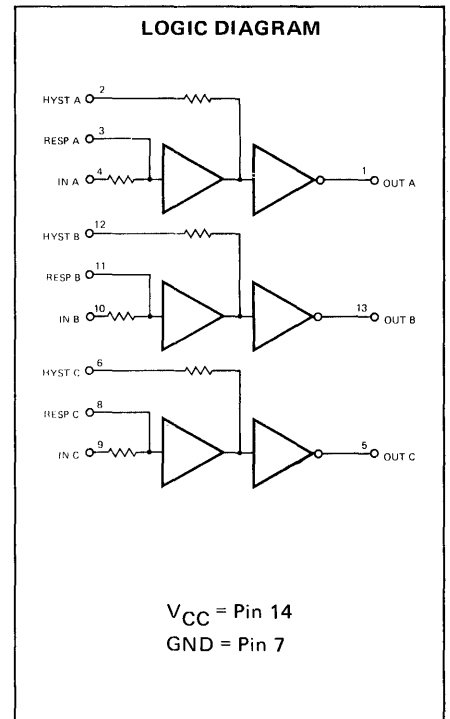

EQUIVALENT CIRCUIT (One of three identical circuits)

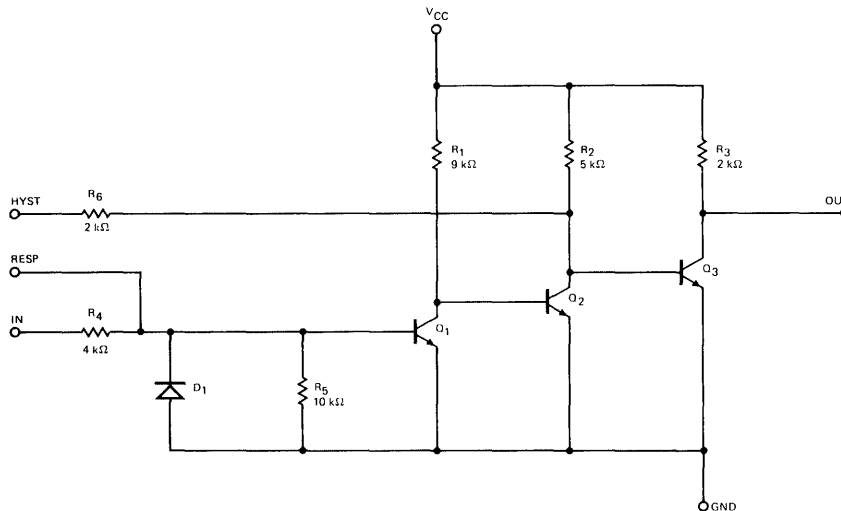

*Planar is a patented Fairchild process.

μA9620

DUAL DIFFERENTIAL LINE RECEIVER

FAIRCHILD LINEAR INTEGRATED CIRCUIT

GENERAL DESCRIPTION – The μA9620 is a Dual Differential Line Receiver designed to receive differential digital data from transmission lines and operate over the military and industrial temperature ranges. It can receive ±500 mV of differential data in the presence of HIGH level (±15 V) common mode voltages and deliver undisturbed TTL logic to the output. In addition to line reception the μA9620 can perform many functions, a few of which are presented in the applications section. It can interface with nearly all input logic levels including CML, CTL, HLLDTL, RTL and TTL. HLLDTL logic can be provided by tying the output to V_{CC2} (+12 V) through a resistor. The outputs can also be wired-OR. The μA9620 offers the advantages of logic compatible voltages (+5 V, +12 V), TTL output characteristics, and a flexible input array with a high common mode range. The direct inputs are provided in addition to the attenuated inputs (normally used) to allow the input attenuation and response time to be changed by use of external components.

- TTL COMPATIBLE OUTPUT
- HIGH COMMON MODE VOLTAGE RANGE
- WIRED-OR CAPABILITY
- DIRECT INPUTS (A_D, B_D)
- FULL MILITARY TEMPERATURE RANGE
- LOGIC COMPATIBLE SUPPLY VOLTAGES

ABSOLUTE MAXIMUM RATINGS (above which the useful life may be impaired)

Storage Temperature	–65° C to +150° C
Temperature (Ambient) Under Bias	–55° C to +125° C
V _{CC1} Pin Potential to Ground Pin	–0.5 V to +7.0 V
Input Voltage Referred to Ground (Attenuator Inputs)	±20 V
Voltage Applied to Outputs for HIGH Output State	–0.5 V to +13.2 V
V _{CC2} Pin Potential to Ground Pin	V _{CC1} to +15 V
Lead Temperature (Soldering, 60 seconds)	300° C
Internal Power Dissipation (Note 1)	
Ceramic DIP	670 mW
Flatpak	570 mW

NOTE

1. Rating applies to ambient temperatures up to 70° C. Above 70° C derate linearly at 8.3 mW/°C for the Ceramic DIP and 7.1 mW/°C for the Flatpak Package.

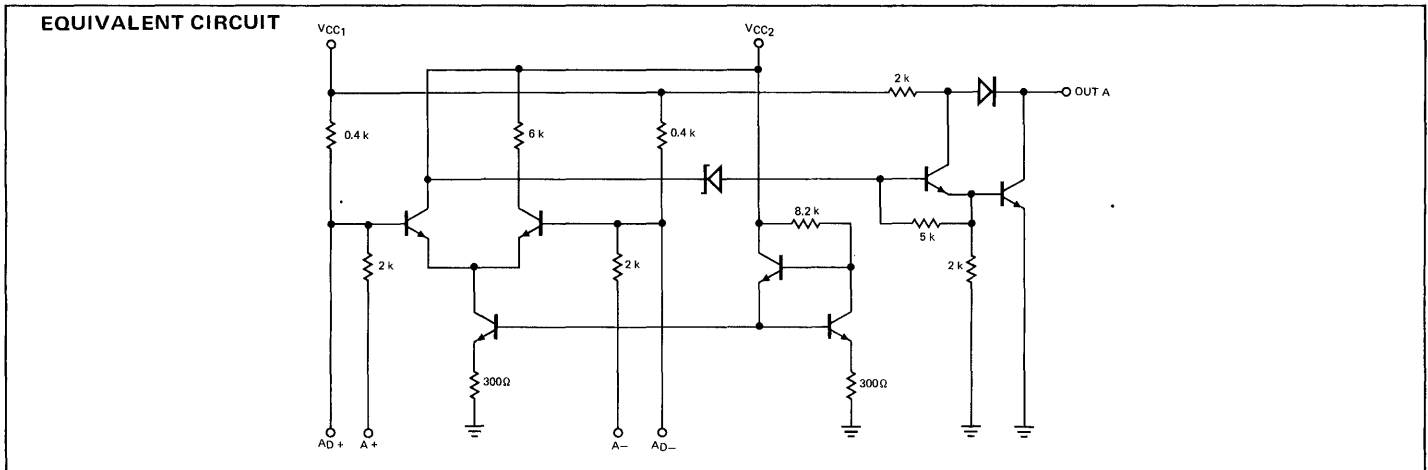
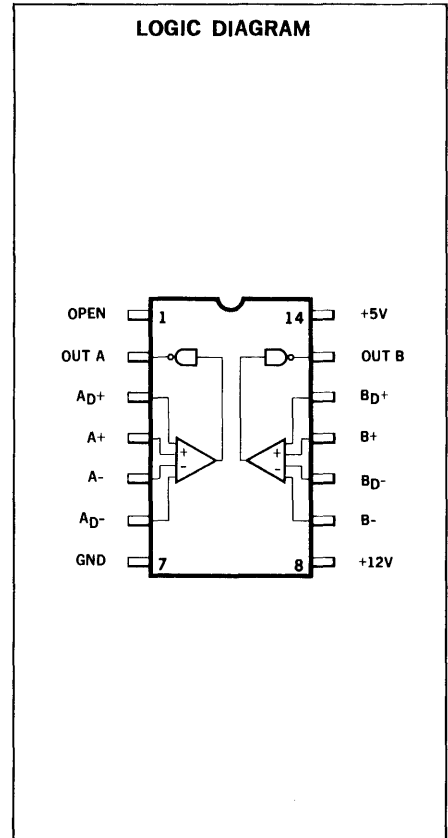

μA9621

DUAL LINE DRIVER

FAIRCHILD LINEAR INTEGRATED CIRCUITS

GENERAL DESCRIPTION — The μA9621 was designed to drive transmission lines in either a differential or a single-ended mode. Output clamp diodes and back-matching resistors for 130 Ω twisted pair are provided. The output has the capability of driving high capacitance loads. It can typically switch >200 mA during transients.

- TTL COMPATIBILITY
- TRANSMISSION LINE BACK-MATCHING
- OUTPUT CLAMP DIODES
- HIGH CAPACITANCE DRIVE
- HIGH OUTPUT VOLTAGE
- MILITARY TEMPERATURE RANGE

ABSOLUTE MAXIMUM RATINGS (above which the useful life may be impaired)

Storage Temperature	-65°C to +150°C
Temperature (Ambient) Under Bias	-55°C to +125°C
V _{CC1} Pin Potential to Ground Pin	+3.8 V to +8 V
Input Voltage	-0.5 V to +15 V
Voltage Applied to Outputs	-2 V to +V _{CC1} +1 V
V _{CC2} Pin Potential to Ground Pin	V _{CC1} to +15 V
Lead Temperature (Soldering, 60 seconds)	300°C
Internal Power Dissipation (Note)	
Ceramic DIP	670 mW
Flatpak	570 mW

NOTE

Rating applies to ambient temperatures up to 70°C. Above 70°C derate linearly at 8.3 mW/°C for the Ceramic DIP and 7.1 mW/°C for the Flatpak Package.

LOGIC DIAGRAM

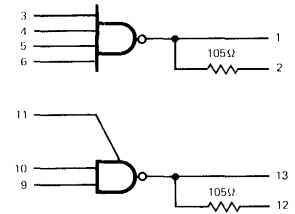

V_{CC1} = 14, V_{CC2} = 8, GND = 7

SCHEMATIC DIAGRAM (ONE SIDE ONLY)

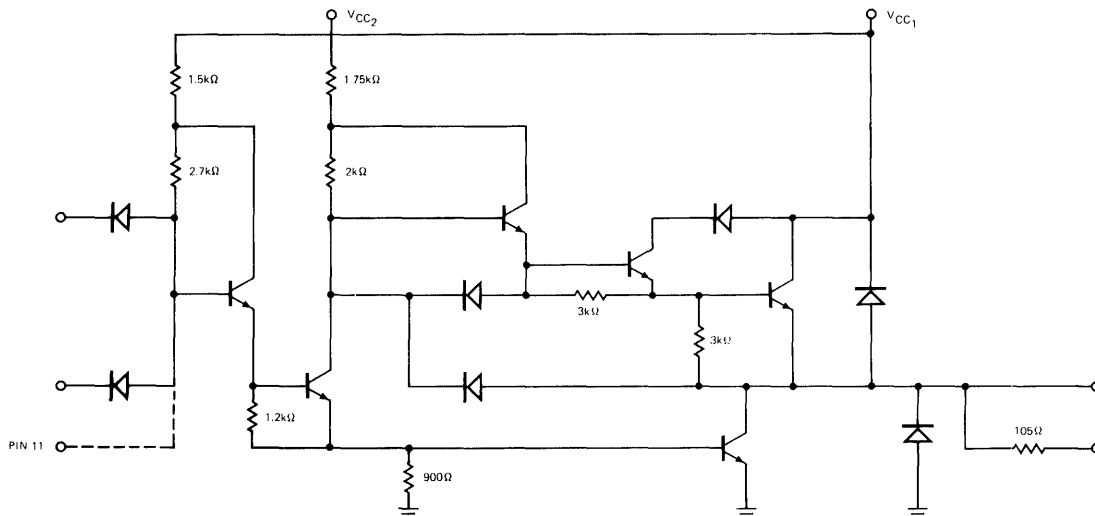

μA9622

DUAL LINE RECEIVER

FAIRCHILD LINEAR INTEGRATED CIRCUIT

GENERAL DESCRIPTION – The μA9622 is a Dual Line Receiver designed to discriminate a worst case logic swing of 2.0 V from a ±10 V common mode noise signal or ground shift. A 1.5 V threshold is built into the differential amplifier to offer a TTL compatible threshold voltage and maximum noise immunity. The offset is obtained by use of current sources and matched resistors and varies only ±5% (75 mV) over the military and industrial temperature ranges.

The μA9622 allows the choice of output states with the inputs open without affecting circuit performance by use of S_3^* . A 130 Ω terminating resistor is provided at the input of each line receiver. An enable is also provided for each line receiver. The output is TTL compatible. The output HIGH level can be increased to +12 V by tying it to a positive supply through a resistor. The output circuits allow wired-OR operation.

* S_3 connected to V_{CC} – open inputs causes output to be V_{OH} .
 S_3 connected to Ground – open inputs causes output to be V_{OL} .

- TTL COMPATIBLE THRESHOLD VOLTAGE
- INPUT TERMINATING RESISTORS
- CHOICE OF OUTPUT STATE WITH INPUTS OPEN
- TTL COMPATIBLE OUTPUT
- HIGH COMMON MODE
- WIRE-OR CAPABILITY
- ENABLE INPUTS
- FULL MILITARY TEMPERATURE RANGE
- LOGIC COMPATIBLE SUPPLY VOLTAGES

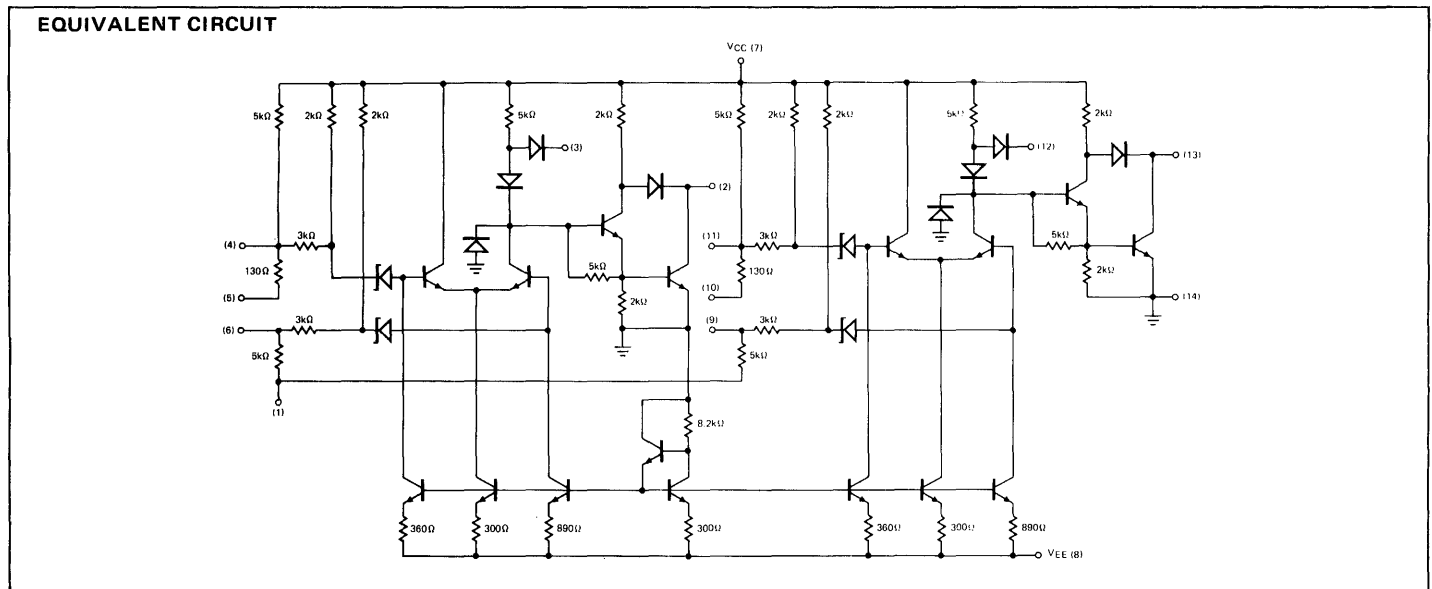
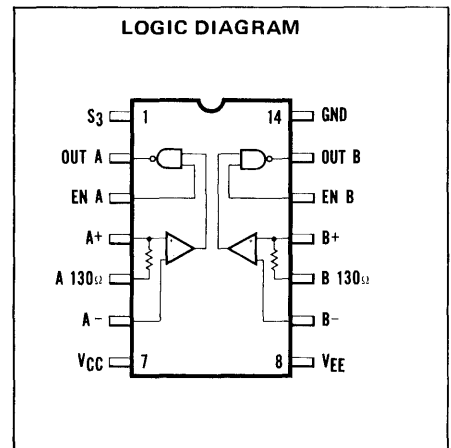

μA9624 • μA9625

DUAL TTL, MOS INTERFACE ELEMENTS

FAIRCHILD LINEAR INTEGRATED CIRCUITS

GENERAL DESCRIPTION – The μA9624 is a Dual 2-Input TTL Compatible Interface gate specifically designed to drive MOS. The output swing is adjustable and will allow it to be used as a data driver, clock driver or discrete MOS driver. It has an active output for driving medium capacitive loads.

The μA9625 is a dual MOS to TTL level converter. It is designed to convert standard negative MOS logic levels to TTL levels. The μA9625 features a high input impedance which allows preservation of the driving MOS logic level.

Both the μA9624 and μA9625 are available in the 14-lead Ceramic Dual In-Line Package and the 1/4 x 1/4 Flatpak.

NOTE: The TTL and MOS devices manufactured by Fairchild Semiconductor are considered as positive TRUE logic (the more positive voltage level is assigned the binary state of "1" or TRUE). Following MIL-STD-806B logic symbol specifications, the μA9624 is represented as a NAND gate and the μA9625 as a non-inverting buffer. This convention (of assuming MOS as a positive TRUE logic) has not been uniformly accepted by the industry; therefore, it is necessary to note that with negative TRUE MOS logic (the more negative voltage level is assigned the binary state "1" or TRUE), the μA9624 acts as an AND gate and the μA9625 as an inverter.

- TTL COMPATIBLE INPUTS/OUTPUT
- MOS COMPATIBLE OUTPUT/INPUTS
- LOW POWER

ABSOLUTE MAXIMUM RATINGS (above which the useful life may be impaired)

Storage Temperature	-65° C to +150° C
Temperature (Ambient) Under Bias	-55° C to +125° C
V _{CC} Pin Potential to Ground Pin	V _{DD} to +10 V
Voltage Applied to Outputs for HIGH Output State (μA9624)	V _{DD} to +V _{CC} value
Voltage Applied to Outputs for HIGH Output State (μA9625)	-0.5 V to V _{CC} value
Input Voltage (dc) (μA9624)	-0.5 V to +5.5 V
Input Voltage (dc) (μA9625)	V _{CC} to V _{DD}
V _{DD} Pin Potential to Ground Pin	-30 V to +0.5 V
V _{DD} Pin Potential to Tap Pin (μA9624)	-30 V to +0.5 V
V _{TAP}	V _{CC} +0.5 V
Internal Power Dissipation (Note 3)	
Ceramic DIP	670 mW
Flatpak	570 mW
Lead Temperature (Soldering, 60 seconds)	300° C

LOGIC DIAGRAMS

μA9624

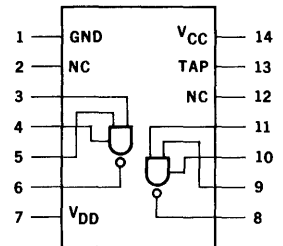

μA9625

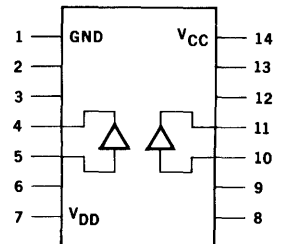

μA9644

DUAL HIGH VOLTAGE, HIGH CURRENT DRIVER

FAIRCHILD LINEAR INTEGRATED CIRCUITS

GENERAL DESCRIPTION – The μA9644 is a Dual 4-Input NAND Gate whose output can sink 500 mA in the LOW state, and maintain 30 V in the HIGH state. The outputs are uncommitted collectors in a Darlington configuration which have typical saturation voltages of 0.8 V at low currents and 1.2 V at 500 mA. The inputs are TTL Compatible and feature input clamp diodes. The input fan in requirement is typically 1/2 a normal DTL Unit Load. An input strobe common to both gates is provided, and an expander input node on each gate is available for input diode expansion. Separate ground pins are provided for each gate to minimize ground pin offset voltages at high current levels.

- 500 mA CURRENT SINKING CAPABILITY
- OUTPUT VOLTAGES UP TO 30 V
- LOW AVERAGE POWER, TYPICALLY 30 mW PER GATE
- HIGH SPEED, TYPICALLY 50 ns DELAY TIMES
- TTL COMPATIBLE INPUTS
- INPUT CLAMP DIODES
- LOW FAN IN LOADING REQUIREMENTS
- COMMON STROBE INPUT
- EXPANDER NODE FOR INPUT DIODE EXPANSION

ABSOLUTE MAXIMUM RATING

Storage Temperature	-65°C to +175°C
Temperature (Ambient) Under Bias	-55°C to +125°C
V _{CC} Pin Potential to Ground Pin	-0.5 V to +8.0 V
Input Voltages (dc)	-0.5 V to +5.5 V
Voltage Applied to Outputs (Output HIGH)	-0.5 V to +30 V
Output Current (dc) (Output LOW)	640 mA
Internal Power Dissipation (Note)	730 mW
Lead Temperature (Soldering, 60 seconds)	300°C

See Safe Area Curves on following pages

NOTE

Rating applies to ambient temperatures up to 70°C. Above 70°C derate linearly at 8.3 mW/°C for the Ceramic DIP.

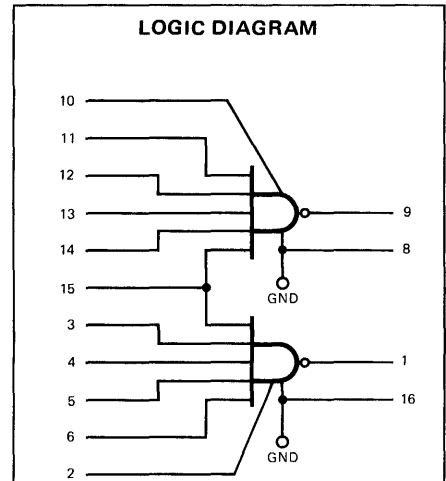

Fig. 1

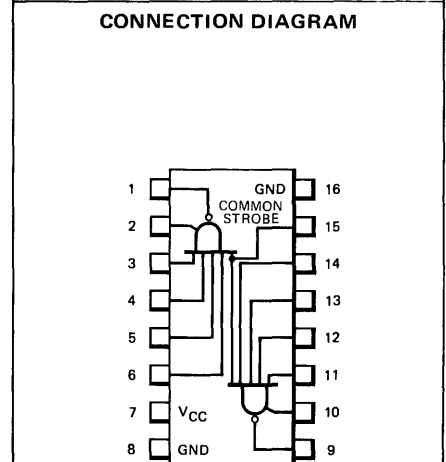
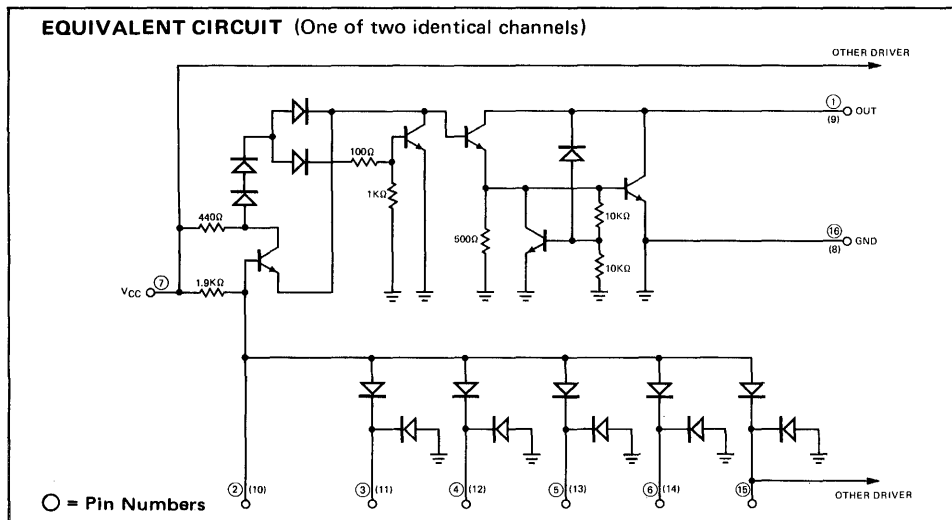

Fig. 2



SN55107 • SN75107 • SN55108 • SN75108

DUAL LINE RECEIVERS

FAIRCHILD LINEAR INTEGRATED CIRCUITS

DESCRIPTION—The SN55107/75107 and SN55108/75108 are high speed, Two-Channel Line Receivers with common voltage supply and ground terminals. They are designed to detect input signals of 25mV (or greater) amplitude and convert the polarity of the signal into appropriate TTL compatible output logic levels. They feature high input impedance and low input currents which induce very little loading on the transmission line making these devices ideal for use in party line systems. The receiver input common mode voltage range is $\pm 3V$ but can be increased to $\pm 15V$ by the use of input attenuators. Separate or common strobes are available. The SN55107/75107 circuit features an active pull-up (totem pole output). The SN55108/75108 circuit features an open collector output configuration that permits wired-OR connections. The receivers are designed to be used with the SN55109/75109 and SN55110/75110 line drivers. The SN55107/75107 and SN55108/75108 line receivers are useful in high speed balanced, unbalanced and party line transmission systems and as data comparators.

- HIGH SPEED
- STANDARD SUPPLY VOLTAGES
- DUAL CHANNELS
- HIGH COMMON-MODE REJECTION RATIO
- HIGH INPUT IMPEDANCE
- HIGH INPUT SENSITIVITY
- INPUT COMMON-MODE VOLTAGE RANGE OF $\pm 3V$
- SEPARATE OR COMMON STROBES
- TTL OR DTL DRIVE CAPABILITY
- WIRED-OR OUTPUT CAPABILITY (SN55108/75108 ONLY)
- HIGH DC NOISE MARGINS

**CONNECTION DIAGRAM
(TOP VIEW)**

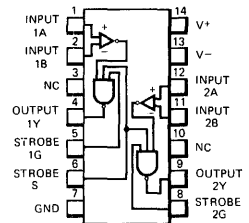

EQUIVALENT CIRCUIT

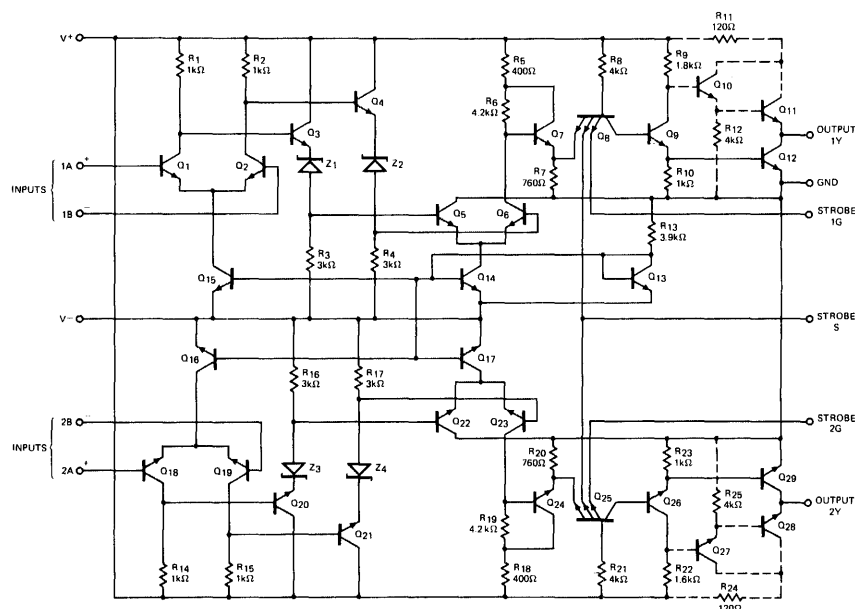

NOTE: Components shown with dashed lines are applicable to the SN55107 and SN75107 only.

SN55109 • SN75109 • SN55110 • SN75110

DUAL LINE DRIVERS

FAIRCHILD LINEAR INTEGRATED CIRCUITS

DESCRIPTION – The SN55109/75109 and SN55110 are Dual Line Drivers featuring independent channels with common supply voltage and ground terminals. The major difference between the SN55109/75109 and the SN55110/75110 drivers is the output-current specification. The output current is nominally 6 mA for the SN55109/75109 and 12 mA for the SN55110/75110. The driver circuits have a constant output that is switched to either of two output terminals by the appropriate logic levels at the input terminals. The output current can be switched off by appropriate logic levels at the inhibit inputs. The circuit also features an inhibit input that is common to both drivers, providing more circuit versatility. The common-mode voltage range of the driver outputs is -3 V to $+10\text{ V}$, which allows a common-mode voltage on the line without affecting the driver performance. For application information see SN55107 • SN75107 • SN55108 • SN75108 Data Sheet.

- **HIGH SPEED**
- **STANDARD SUPPLY VOLTAGES**
- **DUAL CHANNELS**
- **TTL INPUT COMPATIBILITY**
- **CURRENT-MODE OUTPUT (6mA or 12mA TYPICAL)**
- **HIGH OUTPUT IMPEDANCE**
- **HIGH COMMON-MODE OUTPUT VOLTAGE RANGE (-3 V to 10 V)**
- **INHIBITOR AVAILABLE FOR DRIVER SELECTION**

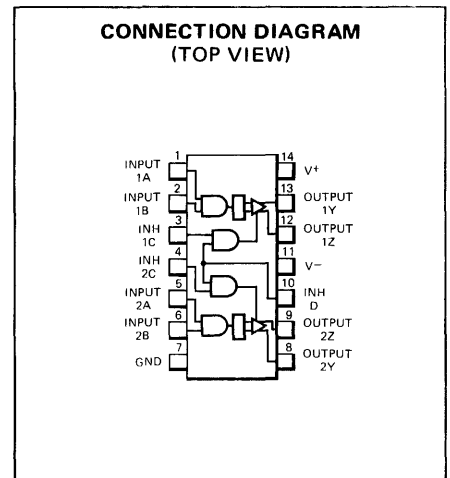

EQUIVALENT CIRCUIT

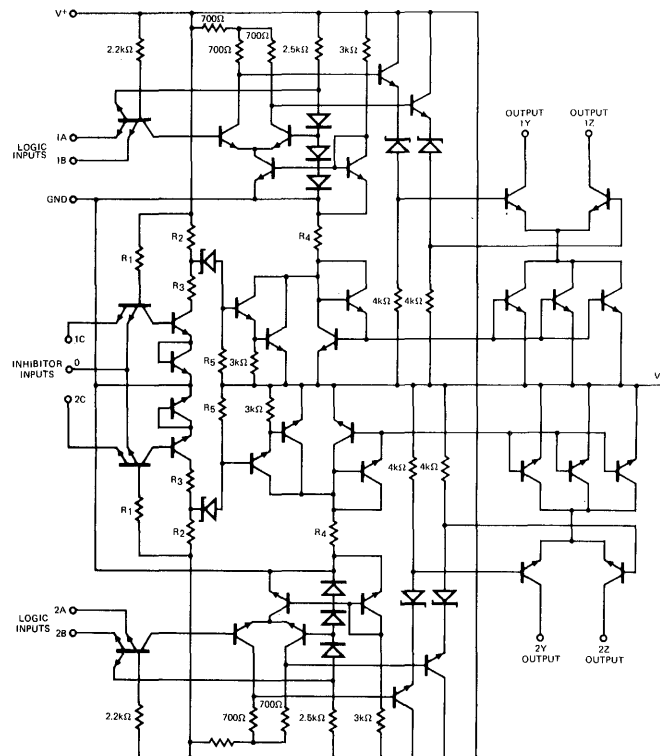

	SN55109	SN55110
R ₁	4 k Ω	2.2 k Ω
R ₂	1.5 k Ω	820 Ω
R ₃	440 Ω	240 Ω
R ₄	1.75 k Ω	875 Ω
R ₅	2.74 k Ω	1.5 k Ω

- NOTES:**
1. Component values shown are nominal.
 2. Resistance values are in ohms.

SN75450

DUAL PERIPHERAL DRIVER

FAIRCHILD LINEAR INTEGRATED CIRCUITS

GENERAL DESCRIPTION — The SN75450 is a versatile general purpose dual interface driver circuit that employs TTL or DTL logic. The SN75450 features two standard series 74 TTL gates and two uncommitted, high current, high voltage transistors offering the system designer the flexibility to tailor the circuit to his application. The SN75450 is useful in high speed logic buffers, power drivers, lamp drivers, relay drivers, line drivers, MOS drivers, clock drivers and memory drivers.

- **HIGH SPEED**
- **300 mA CURRENT CAPABILITY**
- **HIGH VOLTAGE CAPABILITY**
- **UNCOMMITTED OUTPUT DEVICES**
- **TTL OR DTL INPUT COMPATIBILITY**

ABSOLUTE MAXIMUM RATINGS

Supply Voltage (Note 1)	+7 V
Internal Power Dissipation (Note 2)	800 mW
Input Voltage (Note 3)	5.5 V
V _{CC} to Substrate or Collector to Substrate Voltage	35 V
Collector to Base Voltage	35 V
Emitter To Base Voltage	5 V
Collector to Base Voltage (Note 4)	30 V
Continuous Collector Current	300 mA
Operating Temperature Range	0° C to + 70° C
Storage Temperature Range	-65° C to +150° C
Lead Temperature Range (Soldering, 60 seconds)	300° C

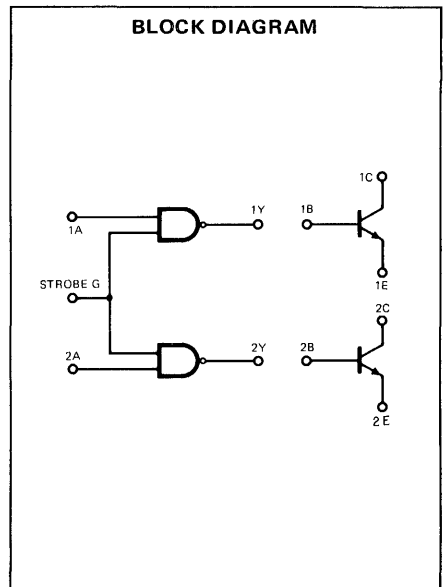
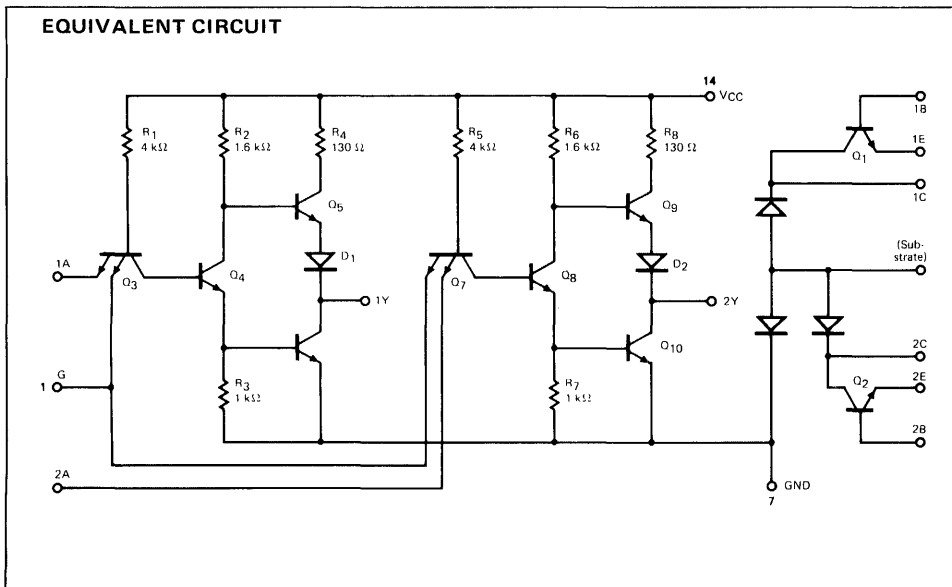
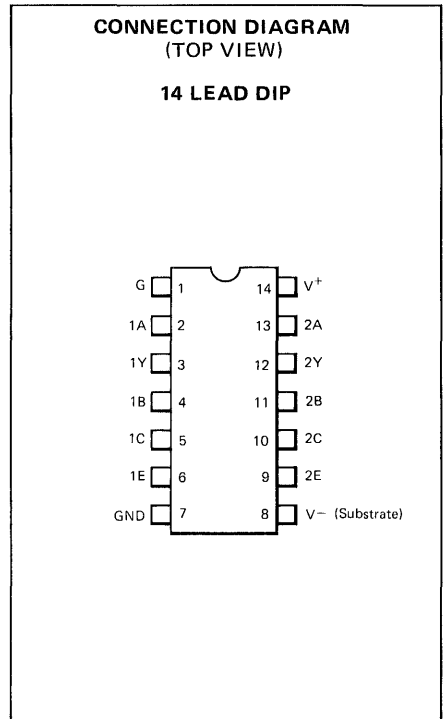

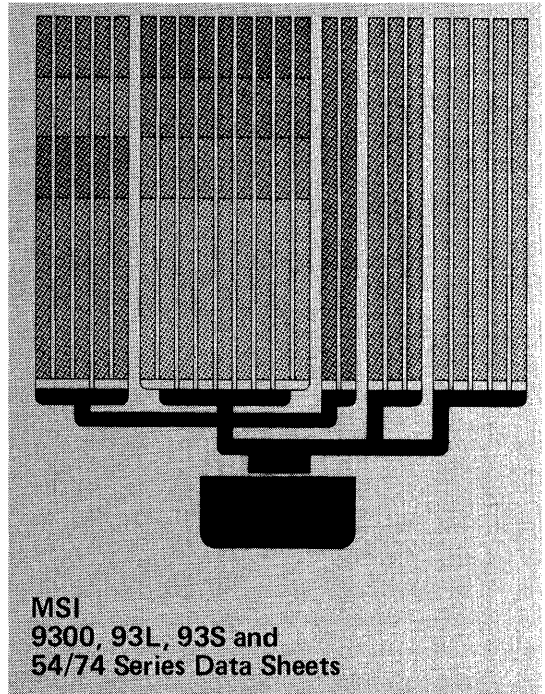

TTL/MSI 9300

4-BIT UNIVERSAL SHIFT REGISTER

DESCRIPTION – The 9300 is a TTL/MSI 4-Bit Universal Shift Register. As a high speed multi-functional sequential logic block, it is useful in a wide variety of register and counter applications. It may be used in serial-serial, shift left, shift right, serial-parallel, parallel-serial, and parallel-parallel data register transfers. This new 9300 replaces the earlier 9300 device in all applications. All requirements of the original 9300 specification are satisfied with the minimum shift rate of 15 MHz being improved to 30 MHz.

- 38 MHz TYPICAL SHIFT FREQUENCY
- ASYNCHRONOUS COMMON RESET
- J, K INPUTS TO FIRST STAGE
- SYNCHRONOUS PARALLEL ENTRY
- TYPICAL POWER DISSIPATION OF 300 mW
- INPUT CLAMP DIODES LIMIT HIGH SPEED TERMINATION EFFECTS
- TTL COMPATIBLE

PIN NAMES

\overline{PE}	Parallel Enable (Active LOW) Input	2.3 U.L.
P_0, P_1, P_2, P_3	Parallel Inputs	1 U.L.
J	First Stage J (Active HIGH) Input	1 U.L.
\overline{K}	First Stage K (Active LOW) Input	1 U.L.
CP	Clock (Active HIGH) Going Edge Input	2 U.L.
\overline{MR}	Master Reset (Active LOW) Input	1 U.L.
Q_0, Q_1, Q_2, Q_3	Parallel Outputs (Note b)	6 U.L.
$\overline{Q_3}$	Complementary Last Stage Output (Note c)	8 U.L.

LOADING (Note a)

2.3 U.L.
1 U.L.
1 U.L.
1 U.L.
2 U.L.
1 U.L.
6 U.L.
8 U.L.

NOTES:

- a. 1 Unit Load (U.L.) = 40 μ A HIGH/1.6 mA LOW
- b. 6 U.L. is the output LOW drive factor and 12 U.L. is the output HIGH drive factor.
- c. 8 U.L. is the output LOW drive factor and 16 U.L. is the output HIGH drive factor.

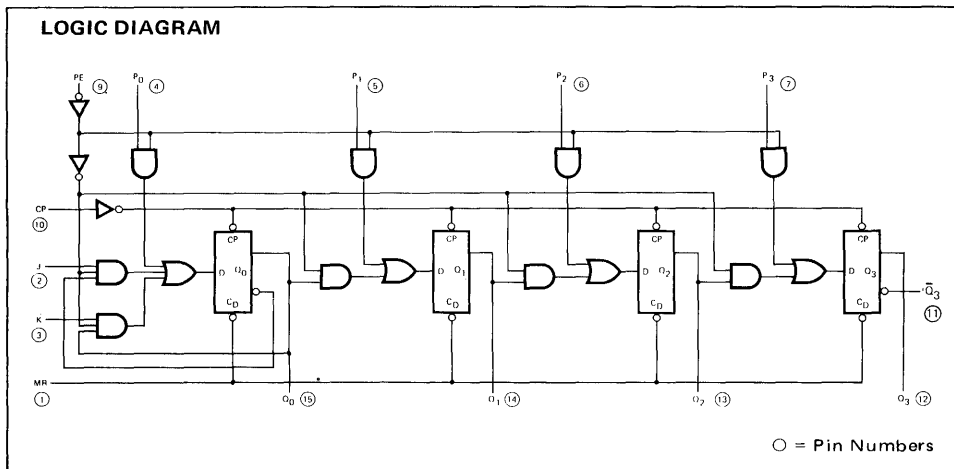

LOGIC SYMBOL

V_{CC} = Pin 16
GND = Pin 8

CONNECTION DIAGRAMS

DIP (TOP VIEW)

FLATPAK (TOP VIEW)

FUNCTIONAL DESCRIPTION — The logic diagram indicates the functional characteristics of the 9300 4-bit shift register. Several special logic features of the 9300 design which increase the range of useful application are:

1. A \overline{JK} input is provided to the first flip-flop in the register. This type of input is the same as the more common JK input except that the LOW voltage level activates the \overline{K} input. This provides the greater power of the JK type input for most general applications. At the same time the simple D type input most appropriate for a shift register can be easily obtained by tying the two inputs together.
2. There is no restriction on the activity of the J or \overline{K} inputs for logic operation—except for the set up and release time requirements.
3. Parallel inputs for all four stages are provided. These will determine the next condition of the shift register synchronous with the clock input, whenever the parallel enable input is LOW. With the parallel enable input LOW, the element appears as four common clocked D flip-flops. When the parallel enable is HIGH, or not connected, the shift register performs a one bit shift for each clock input. In both cases the next state of the flip-flops occurs after the LOW to HIGH transition of the clock input.
4. An internal clock buffer provides both reduced clock input loading, and the ability to gate the clock with only a single NAND gate.
5. The active HIGH output is provided for all four stages and an active LOW output is provided for the last stage.
6. A master asynchronous reset input allows the setting to zero of all stages independent of any other input condition.

TRUTH TABLES

TABLE I—SERIAL ENTRY
(\overline{PE} = HIGH, \overline{MR} = HIGH)

J	\overline{K}	Q_0 at t_{n+1}
L	L	L
L	H	Q_0 at t_n (no change)
H	L	$\overline{Q_0}$ at t_n (toggles)
H	H	H

H = HIGH Voltage Level
L = LOW Voltage Level
X = Don't Care

TABLE III—PARALLEL ENTRY
(\overline{PE} = LOW, \overline{MR} = HIGH)

D-Input (P_0, P_1, P_2 or P_3)	Output Q at t_{n+1} (Q_0, Q_1, Q_2 or Q_3)
L	L
H	H

TABLE II—SERIAL ENTRY
(\overline{PE} = HIGH, \overline{MR} = HIGH)

J& \overline{K} Connected	Q_0 at t_{n+1}
L	L
H	H

TABLE IV—MODE SELECTION

	\overline{PE}	P_0	P_1	P_2	P_3	J	\overline{K}	\overline{MR}
Serial Entry	H	X	X	X	X	Refer to Table I & II		H
Parallel Entry	L	Refer to Table III				X	X	H

(n+1) = Indicates state after next clock

TYPICAL INPUT AND OUTPUT CHARACTERISTICS

INPUTS

EQUIVALENT CIRCUIT

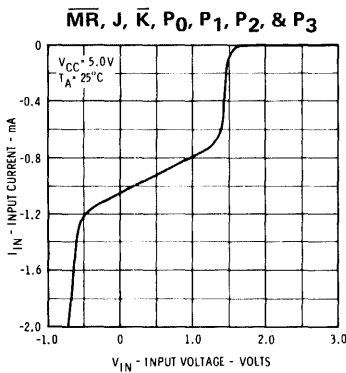
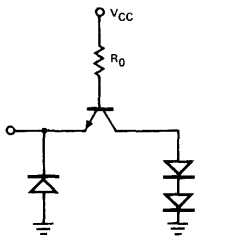

INPUT CURRENT VERSUS INPUT VOLTAGE

\overline{PE}

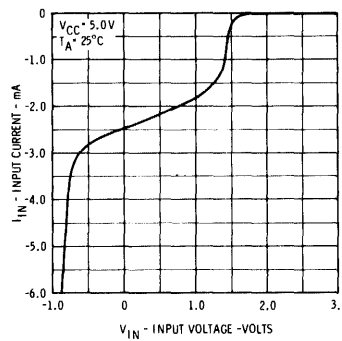

CP

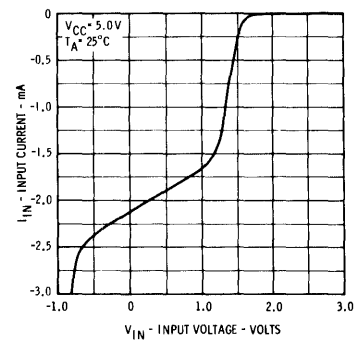

OUTPUTS

EQUIVALENT CIRCUIT

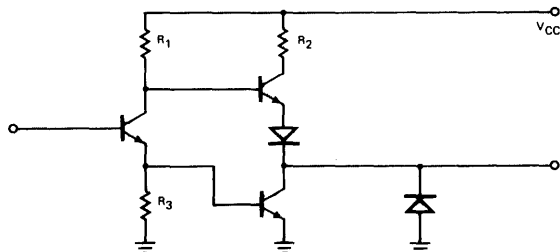

OUTPUT CURRENT VERSUS OUTPUT VOLTAGE
(Q_0, Q_1, Q_2, Q_3 AND $\overline{Q_3}$)

LOW STATE

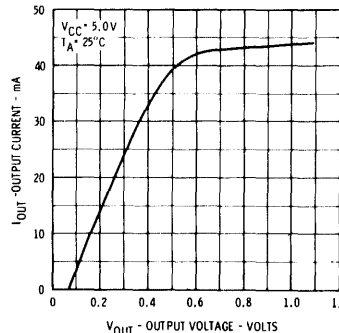

HIGH STATE

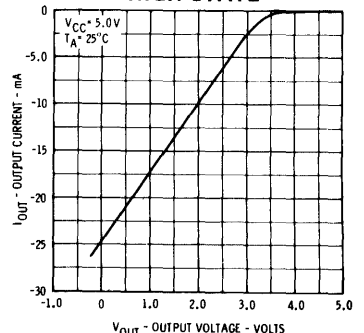

FAIRCHILD TTL/MSI • 9300

ABSOLUTE MAXIMUM RATINGS (above which the useful life may be impaired)

Storage Temperature	-65° C to +150° C
Temperature (Ambient) Under Bias	-55° C to +125° C
V _{CC} Pin Potential to Ground Pin	-0.5 V to +7.0 V
*Input Voltage (dc)	-0.5 V to +5.5 V
*Input Current (dc)	-30 mA to +5.0 mA
Voltage Applied to Outputs (Output HIGH)	-0.5 V to +V _{CC} value
Output Current (dc) (Output LOW)	+30 mA

*Either Input Voltage limit or Input Current limit is sufficient to protect the inputs.

GUARANTEED OPERATING RANGES

PART NUMBER	SUPPLY VOLTAGE (V _{CC})			AMBIENT TEMPERATURE
	MIN.	TYP.	MAX.	
9300XM	4.5 V	5.0 V	5.5 V	-55° C to 125° C
9300XC	4.75 V	5.0 V	5.25 V	0° C to 75° C

X = package type; F for Flatpak, D for Ceramic Dip, P for Plastic Dip. See Packaging Information Section for packages available on this product.

ELECTRICAL CHARACTERISTICS OVER OPERATING TEMPERATURE RANGE (unless otherwise noted)

SYMBOL	PARAMETERS	LIMITS			UNITS	CONDITIONS
		MIN.	TYP. (Note 4)	MAX.		
V _{IH}	Input HIGH Voltage	2.0			Volts	Guaranteed Input HIGH Voltage for All Inputs
V _{IL}	Input LOW Voltage			0.8	Volts	Guaranteed Input LOW Voltage for All Inputs
V _{CD}	Input Clamp Diode Voltage			-1.5	Volts	V _{CC} = MIN., I _{IN} = -12 mA, T _A = 25° C
V _{OH}	Output HIGH Voltage	2.4	3.6		Volts	V _{CC} = MIN., I _{OH} = -640 μA for Q ₃ , and -480 μA for Q ₀ -Q ₃ V _{IN} = V _{IH} or V _{IL} per Truth Table
V _{OL}	Output LOW Voltage		0.2	0.4	Volts	V _{CC} = MIN., I _{OL} = 12.8 mA for Q ₃ and 9.6 mA for Q ₀ -Q ₃ V _{IN} = V _{IH} or V _{IL} per Truth Table
I _{IH}	Input HIGH Current J, K, MR, P ₀ , P ₁ , P ₂ & P ₃ CP PE		10 20 23	40 80 92	μA	V _{CC} = MAX., V _{IN} = 2.4 V
	Input HIGH Current, all inputs			1.0	mA	V _{CC} = MAX., V _{IN} = 5.5 V
I _{IL}	Input LOW Current J, K, MR, P ₀ , P ₁ , P ₂ & P ₃ CP PE		-0.96 -1.92 -2.21	-1.6 -3.2 -3.7	mA	V _{CC} = MAX., V _{IN} = 0.4 V
	Output Short Circuit Current (Note 5)	-20	-40	-80	mA	V _{CC} = MAX., V _{OUT} = 0 V
I _{CC}	Power Supply Current		60	86	mA	9300XM V _{CC} = MAX.
			60	92	mA	9300XC Inputs HIGH

NOTES:

1. The actual testing procedures used to guarantee the Electrical Characteristics are contained in a detailed Customer Sample Specification. A copy of this specification can be obtained from Fairchild Digital Product Marketing, Mountain View, California.
2. Conditions for testing, not shown in the table, are chosen to guarantee operation under "worst case" conditions.
3. The specified LIMITS represent the "worst case" value for the parameter. Since these "worst case" values normally occur at the temperature and supply voltage extremes, additional noise immunity and guard banding can be achieved by decreasing the allowable system operating ranges.
4. Typical limits are at V_{CC} = 5.0 V, 25° C, and maximum loading.
5. Not more than one output should be shorted at a time.

SWITCHING CHARACTERISTICS (T_A = 25°C)

SYMBOL	PARAMETER	LIMITS			UNITS	CONDITIONS	
		MIN.	TYP.	MAX.			
f _{sr}	Shift Right Frequency	30	38		MHz	See Fig. 1.	V _{CC} = 5.0 V C _L = 15 pF
t _{PLH}	Turn Off Delay from Clock to Output		12	22	ns		
t _{PHL}	Turn On Delay from Clock to Output		19	26	ns		
t _{PHL} (\overline{MR})	Turn On Delay from \overline{MR} to OUTPUT (Except Q ₃)		26	37	ns	See Fig. 2.	

SWITCHING SET-UP REQUIREMENTS (T_A = 25°C)

SYMBOL	PARAMETER	LIMITS			UNITS	CONDITIONS	
		MIN.	TYP.	MAX.			
t _{pw} (CP)	Clock Pulse Width	17	11		ns	See Fig. 1	V _{CC} = 5.0 V
t _s (Data)	Set-up Time Data to Clock	20	13		ns	See Fig. 3.	
t _h (Data)	Hold Time Data to Clock	0	-11		ns		
t _s (\overline{PE})	Set-up Time \overline{PE} to Clock	39	24		ns	See Fig. 4	
t _h (\overline{PE})	Hold Time \overline{PE} to Clock	-10	-20		ns		
t _{pw} (\overline{MR})	Master Reset Pulse Width	25	13		ns	See Fig. 2.	
t _{rec} (\overline{MR})	Recovery Time Master Reset to Clock	25	12		ns		

DEFINITION OF TERMS

SET-UP TIME (t_s) is defined as the minimum time required for the correct logic level to be present at the logic input prior to the clock transition from LOW to HIGH in order to be recognized and transferred to the outputs.

HOLD TIME (t_h) is defined as the minimum time following the clock transition from LOW to HIGH that the logic level must be maintained at the input in order to insure continued recognition. A negative HOLD TIME indicates that the correct logic level may be released prior to the clock transition from LOW to HIGH and still be recognized.

RECOVERY TIME (t_{rec}) is defined as the minimum time required between the end of the Reset pulse and the clock transition from LOW to HIGH in order to recognize and transfer HIGH Data to the Q outputs.

SWITCHING TIME WAVEFORMS

Clock to Output Delays and Clock Pulse Width.

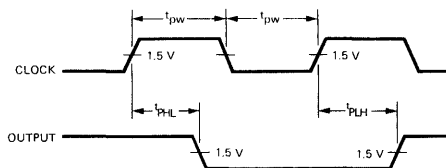

OTHER CONDITIONS: J = \overline{PE} = \overline{MR} = H
K = L

Fig. 1.

Master Reset Pulse Width, Master Reset to Output Delay and Master Reset to Clock Recovery Time.

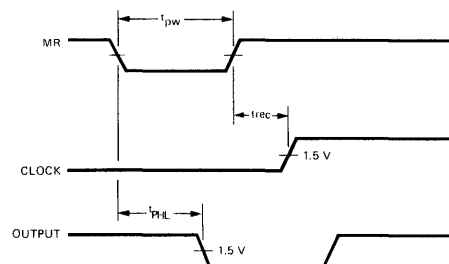

OTHER CONDITIONS: \overline{PE} = L
P₀ = P₁ = P₂ = P₃ = H

Fig. 2.

SWITCHING TIME WAVEFORMS
(Cont't)

Set-up (t_s) and Hold (t_h) Time for Serial Data (J and \bar{K}) and Parallel Data (P_0, P_1, P_2 and P_3)

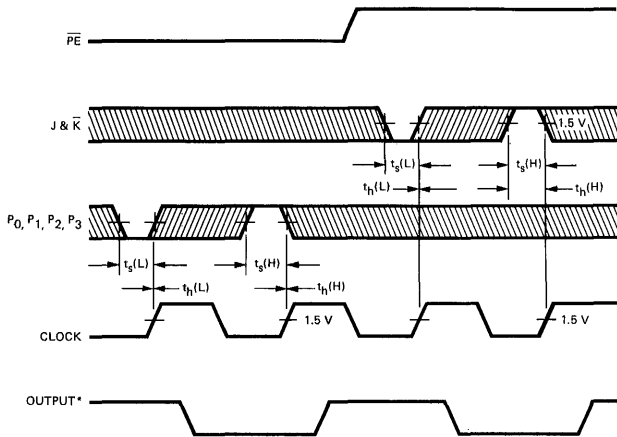

OTHER CONDITIONS: $\bar{M}\bar{R} = H$
*J & \bar{K} SET-UP TIME AFFECTS Q_0 ONLY

Fig. 3.

Set-up (t_s) and Hold (t_h) Time for $\bar{P}\bar{E}$ Input.

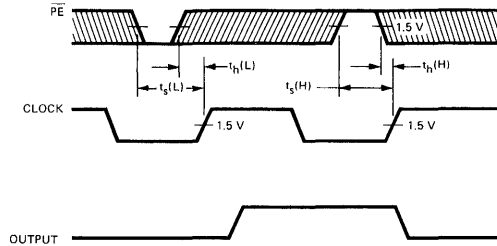

OTHER CONDITIONS: $\bar{M}\bar{R} = H, J = \bar{K} = L$
 $P_0 = P_1 = P_2 = P_3 = H$

Fig. 4.

Note: The shaded areas indicate when the input is permitted to change for predictable output performance.

TYPICAL SWITCHING CHARACTERISTICS

SWITCHING PERFORMANCE
CLOCK TO OUTPUT (Q_3) DELAY
AND MASTER RESET TO OUTPUT DELAY
VERSUS TEMPERATURE

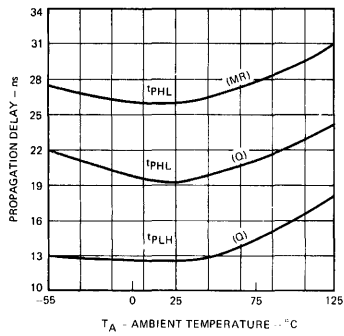

CLOCK FREQUENCY
VERSUS
AMBIENT TEMPERATURE

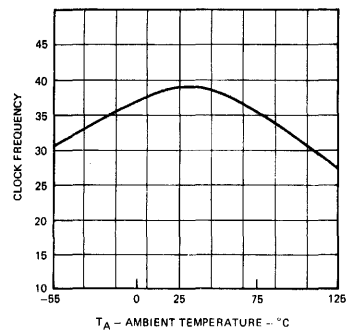

TTL/MSI 93H00

HIGH SPEED UNIVERSAL 4-BIT SHIFT REGISTER

DESCRIPTION — The 93H00 is a TTL/MSI 4-Bit Universal Shift Register offering a typical shift frequency to 55 MHz and guaranteed minimum value of 45 MHz. These features make the 93H00 useful in a wide range of high speed register and counter applications. These include serial-serial, shift left, shift right, serial-parallel, parallel-serial and parallel-parallel data registers.

The 93H00 is pin compatible with the 9300 and 93L00 shift registers. Major electrical differences are the speed of operation and resulting power dissipation.

- 55 MHz TYPICAL SHIFT FREQUENCY
- ASYNCHRONOUS COMMON RESET
- J, \bar{K} INPUTS TO FIRST STAGE
- SYNCHRONOUS PARALLEL ENTRY
- TYPICAL POWER DISSIPATION OF 350 mW
- INPUT CLAMP DIODES LIMIT HIGH SPEED TERMINATION EFFECTS
- PIN FOR PIN COMPATIBLE WITH 9300A AND 93L00 DEVICES

PIN NAMES

\bar{PE}	Parallel Enable (Active LOW) Input	1 U.L.
P_0, P_1, P_2, P_3	Parallel Inputs	1 U.L.
J	First Stage J (Active HIGH) Input	1 U.L.
\bar{K}	First Stage K (Active LOW) Input	1 U.L.
CP	Clock (Active HIGH) Going Edge Input	2 U.L.
\bar{MR}	Master Reset (Active LOW) Input	1 U.L.
Q_0, Q_1, Q_2, Q_3	Parallel Outputs (Note b)	8 U.L.
\bar{Q}_3	Complementary Last Stage Output (Note b)	10 U.L.

LOADING

(Note a)

NOTES

- a. 1 Unit Load (U.L.) = 40 μ A HIGH/1.6 mA LOW
 b. 10 U.L. is the output LOW drive factor and 20 U.L. is the output HIGH drive factor

LOGIC DIAGRAM

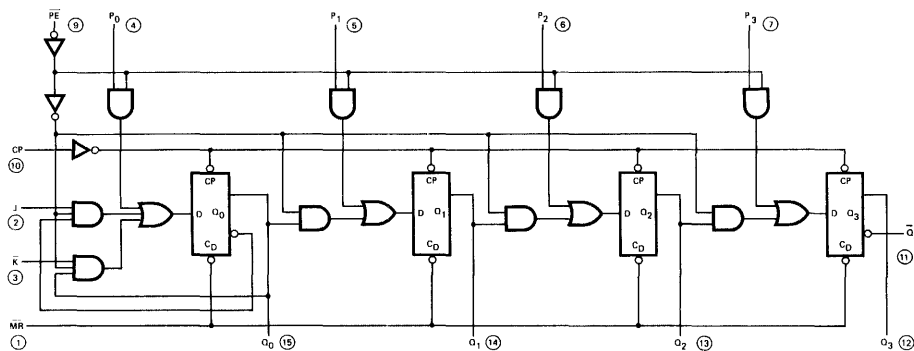

○ = Pin Numbers

LOGIC SYMBOL

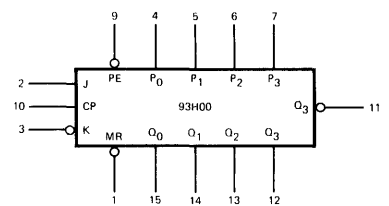

V_{CC} = Pin 16
 GND = Pin 8

CONNECTION DIAGRAMS

DIP (TOP VIEW)

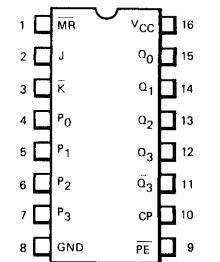

FLATPAK (TOP VIEW)

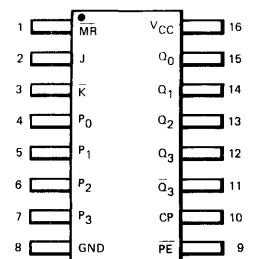

FUNCTIONAL DESCRIPTION — The logic diagram indicates the functional characteristics of the 93H00 4-bit shift register. Special logic features of the 93H00 design which increase the range of application are described below:

1. A $J\bar{K}$ input is provided to the first flip-flop in the register. This type of input is the same as the more common JK input except that the LOW voltage level activates the \bar{K} input. This provides the greater power of the JK type input for most general applications. At the same time the simple D type input most appropriate for a shift register can be easily obtained by tying the two inputs together.
2. There is no restriction on the activity of the J or \bar{K} inputs for logic operation—except for the set up and release time requirements.
3. Parallel inputs for all four stages are provided. These will determine the next condition of the shift register synchronous with the clock input, whenever the Parallel Enable input is LOW. With the Parallel Enable input LOW, the element appears as four common clocked D flip-flops. When the Parallel Enable is HIGH, or not connected, the shift register performs a one bit shift for each clock input. In both cases the next state of the flip-flops occurs after the LOW to HIGH transition of the clock input.
4. An internal clock buffer provides both reduced clock input loading, and the ability to gate the clock with only a single NAND gate.
5. The active HIGH output is provided for all four stages and an active LOW output is provided for the last stage.
6. A master asynchronous reset input allows the setting to zero of all stages independent of any other input condition.

TRUTH TABLES

TABLE I — SERIAL ENTRY
($\bar{P}E = \text{HIGH}, \bar{M}R = \text{HIGH}$)

J	\bar{K}	Q_0 at t_{n+1}
L	L	L
L	H	Q_0 at t_n (no change)
H	L	\bar{Q}_0 at t_n (toggles)
H	H	H

TABLE II — SERIAL ENTRY
($\bar{P}E = \text{HIGH}, \bar{M}R = \text{HIGH}$)

J & \bar{K} Connected	Q_0 at t_{n+1}
L	L
H	H

TABLE III — PARALLEL ENTRY
($\bar{P}E = \text{LOW}, \bar{M}R = \text{HIGH}$)

D-Input (P_0, P_1, P_2 or P_3)	Output Q at t_{n+1} (Q_0, Q_1, Q_2 or Q_3)
L	L
H	H

TABLE IV — MODE SELECTION

	$\bar{P}E$	P_0	P_1	P_2	P_3	J	\bar{K}	$\bar{M}R$
Serial Entry	H	X	X	X	X	Refer to Table I & II		H
Parallel Entry	L	Refer to Table III				X	X	H

H = HIGH Voltage Level
L = LOW Voltage Level
X = Don't Care

(n+1) = Indicates state after next clock

TYPICAL INPUT AND OUTPUT CIRCUITS

**INPUTS
EQUIVALENT CIRCUIT**

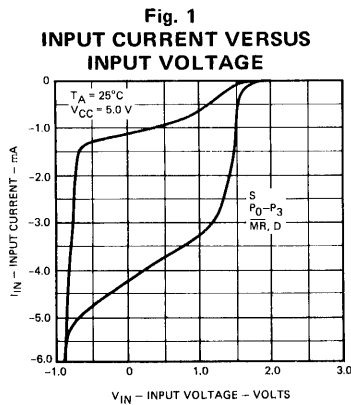
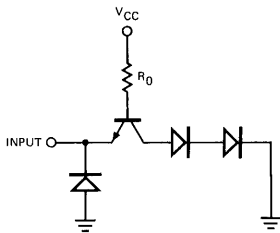

**OUTPUTS
EQUIVALENT CIRCUIT**

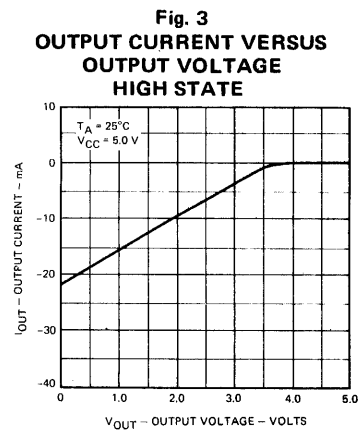
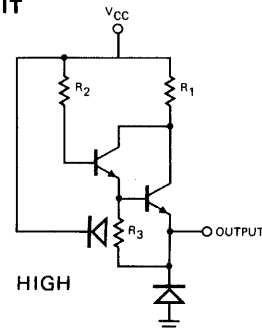
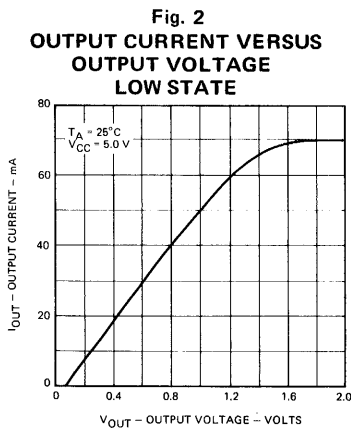
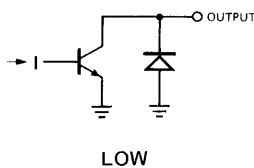

FAIRCHILD TTL/MSI • 93H00

ABSOLUTE MAXIMUM RATINGS (above which the useful life may be impaired)

Storage Temperature	-65°C to +150°C
Temperature (Ambient) Under Bias	-55°C to +125°C
V _{CC} Pin Potential to Ground Pin	-0.5 V to +7.0 V
*Input Voltage (dc)	-0.5 V to +5.5 V
*Input Current (dc)	-30 mA to +5.0 mA
Voltage Applied to Outputs (Output HIGH)	-0.5 V to +V _{CC} value
Output Current (dc) (Output LOW)	+30 mA

*Either Input Voltage limit or Input Current limit is sufficient to protect the inputs.

GUARANTEED OPERATING RANGES

PART NUMBER	SUPPLY VOLTAGE (V _{CC})			AMBIENT TEMPERATURE
	MIN.	TYP.	MAX.	
93H00XM	4.5 V	5.0 V	5.5 V	-55°C to 125°C
93H00XC	4.75 V	5.0 V	5.25 V	0°C to 75°C

X=package type; F for Flatpak, D for Ceramic Dip, P for Plastic Dip. See Packaging Information Section for packages available on this product.

ELECTRICAL CHARACTERISTICS OVER OPERATING TEMPERATURE RANGE (unless otherwise noted)

SYMBOL	PARAMETER	LIMITS			UNITS	CONDITIONS
		MIN.	TYP. (Note 4)	MAX.		
V _{OH}	Output HIGH Voltage	2.4	3.6		Volts	V _{CC} = MIN., I _{OH} = -0.64 mA (-0.8 mA, Pin 11) V _{IN} = V _{IH} or V _{IL} per Truth Table
V _{OL}	Output LOW Voltage		0.2	0.4	Volts	V _{CC} = MIN., I _{OL} = 12.8 mA (16 mA, Pin 11) V _{IN} = V _{IH} or V _{IL} per Truth Table
V _{IH}	Input HIGH Voltage	2.0			Volts	Guaranteed Input HIGH Threshold Voltage for All Inputs
V _{IL}	Input LOW Voltage			0.8	Volts	Guaranteed Input LOW Threshold Voltage for All Inputs
V _{CD}	Input Clamp Diode Voltage			-1.5	Volts	V _{CC} = MIN., I _{IN} = -12 mA, T _A = 25°C
I _{IL}	Input LOW Current J, K, MR, P ₀ , P ₁ , P ₂ & P ₃ , \overline{PE} CP		-0.96 -1.92	-1.6 -3.2	mA	V _{CC} = MAX., V _{IN} = 0.4 V
I _{IH}	Input HIGH Current J, K, MR, P ₀ , P ₁ , P ₂ & P ₃ , \overline{PE} CP			40 80	μA	V _{CC} = MAX., V _{IN} = 2.4 V
	Input HIGH Current			1.0	mA	V _{CC} = MAX., V _{IN} = 5.5 V
I _{SC}	Output Short Circuit Current (Note 5)	-30	-75	-100	mA	V _{CC} = MAX., V _{OUT} = 0 V
I _{CC}	Power Supply Current	93H00XM	65	102	mA	V _{CC} = MAX.
		93H00XC	65	112		

NOTES:

1. The actual testing procedures used to guarantee the Electrical Characteristics are contained in a detailed Customer Sample Specification. A copy of this specification can be obtained from Fairchild Digital Product Marketing, Mountain View, California.
2. Conditions for testing, not shown in the table, are chosen to guarantee operation under "worst case" conditions.
3. The specified LIMITS represent the "worst case" value for the parameter. Since these "worst case" values normally occur at the temperature and supply voltage extremes, additional noise immunity and guard banding can be achieved by decreasing the allowable system operating ranges.
4. Typical limits are at V_{CC} = 5.0 V, 25°C, and maximum loading.
5. Not more than one output should be shorted at a time.

SWITCHING CHARACTERISTICS (T_A = 25°C)

SYMBOL	PARAMETER	LIMITS			UNITS	TEST CONDITIONS
		MIN.	TYP.	MAX.		
f _{sr}	Shift Right Frequency	45	55		MHz	Fig. 4 V _{CC} = 5.0 V C _L = 15 pF
t _{PLH}	Turn Off Delay from Clock to Output		10	16	ns	
t _{PHL}	Turn on Delay from Clock to Output		14.5	21	ns	
t _{PHL} (MR)	Turn on Delay from MR to Output (Except Q ₃)		21	28	ns	

SWITCHING SET-UP REQUIREMENTS (T_A = 25°C)

SYMBOL	PARAMETER	MIN.	TYP.	MAX.	UNITS	TEST CONDITIONS
t _{pw} (CP)	Clock Pulse Width	12	9.0		ns	Fig. 4
t _s (Data)	Set-Up Time Data to Clock	12	6.0		ns	Fig. 6
t _h (Data)	Hold Time Data to Clock	0	-5.0		ns	Fig. 7
t _s (PE)	Set-Up Time PE to Clock	15	8.0		ns	
t _h (PE)	Hold Time PE to Clock	0	-7.0		ns	Fig. 5
t _{pw} (MR)	Master Reset Pulse Width	19	11		ns	
t _{rec} (MR)	Recovery Time Master Reset to Clock	7.0	3.0		ns	

SET-UP TIME (t_s) is defined as the minimum time required for the correct logic level to be present at the logic input prior to the clock transition from LOW to HIGH in order to be recognized and transferred to the outputs.

HOLD TIME (t_h) is defined as the minimum time following the clock transition from LOW to HIGH that the logic level must be maintained at the input in order to insure continued recognition. A negative HOLD TIME indicates that the correct logic level may be released prior to the clock transition from LOW to HIGH and still be recognized.

RECOVERY TIME (t_{rec}) is defined as the minimum time required between the end of the reset pulse and the clock transition from LOW to HIGH in order to recognize and transfer HIGH data to the Q outputs.

SWITCHING TIME WAVEFORMS

The shaded areas indicate when the input is permitted to change for predictable output performance.

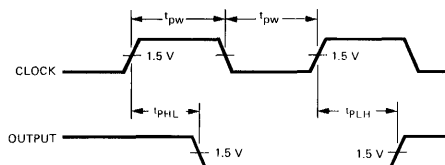

Other Conditions: J = \overline{PE} = \overline{MR} = H
K = L

Fig. 4 - CLOCK TO OUTPUT DELAYS & CLOCK PULSE WIDTH

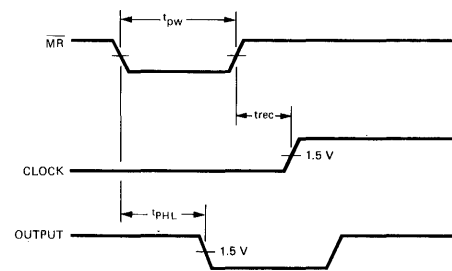

Other Conditions: \overline{PE} = L
P₀ = P₁ = P₂ = P₃ = H

Fig. 5 - MASTER RESET PULSE WIDTH, MASTER RESET TO OUTPUT DELAY & MASTER RESET TO CLOCK RECOVERY TIME

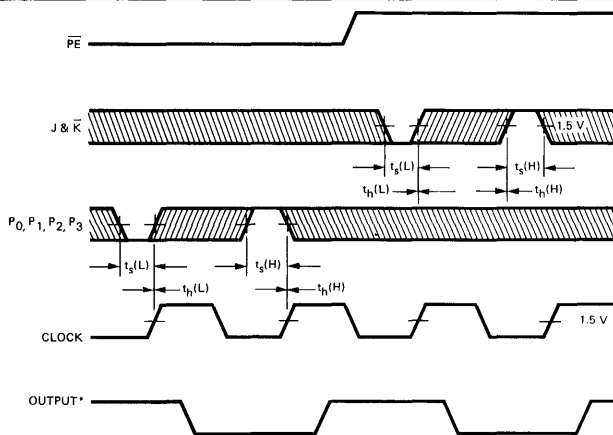

Other Conditions: \overline{MR} = H
*J&K Set-Up Time Affects Q₀ Only

Fig. 6 - SET-UP (t_s) AND HOLD (t_h) TIME FOR SERIAL DATA (J&K) AND PARALLEL DATA (P₀, P₁, P₂, P₃)

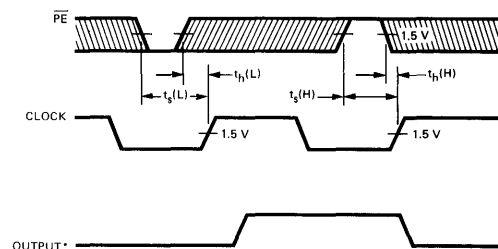

Other Conditions: \overline{MR} = H, J = \overline{K} = L
P₀ = P₁ = P₂ = P₃ = H
*t_s(H) and t_h(H) Affects Q₀ Only

Fig. 7 - SET-UP (t_s) AND HOLD (t_h) TIME FOR \overline{PE} INPUT

LPTTL/MSI 93L00

LOW POWER 4-BIT SHIFT REGISTER

DESCRIPTION — The LPTTL/MSI 93L00 4-Bit Shift Register is a medium speed multi-functional sequential logic block, useful in a wide variety of register and counter applications. As a register it may be used in serial-serial, shift left, shift right, serial-parallel, parallel-serial, and parallel-parallel data transfers. The circuit uses TTL technology for high speed and high fanout capability, and is compatible with the Fairchild TTL family.

- 15 MHz TYPICAL SHIFT FREQUENCY
- ASYNCHRONOUS COMMON RESET
- J, \bar{K} INPUTS TO FIRST STAGE
- SYNCHRONOUS PARALLEL ENTRY
- TYPICAL POWER DISSIPATION OF 75 mW
- INPUT CLAMP DIODES LIMIT HIGH SPEED TERMINATION EFFECTS
- ALL CERAMIC "HERMETIC" 16-LEAD DUAL IN-LINE AND FLAT PACKAGES
- TTL COMPATIBLE

PIN NAMES

\overline{PE}	Parallel Enable (Active LOW) Input
P_0, P_1, P_2, P_3	Parallel Inputs
J	First Stage J (Active HIGH) Input
\bar{K}	First Stage K (Active LOW) Input
CP	Clock (Active HIGH Going Edge) Input
\overline{MR}	Master Reset (Active LOW) Input
Q_0, Q_1, Q_2, Q_3	Parallel Outputs
\bar{Q}_3	Complementary Last Stage Output

LOADING

	HIGH	LOW
1.15 U.L.	0.575 U.L.	
0.5 U.L.	0.25 U.L.	
0.5 U.L.	0.25 U.L.	
1.0 U.L.	0.5 U.L.	
0.5 U.L.	0.25 U.L.	
8.0 U.L.	2.0 U.L.	
8.0 U.L.	2.0 U.L.	

1 Unit Load (U.L.) = 40 μ A HIGH/1.6 mA LOW.

LOGIC SYMBOL

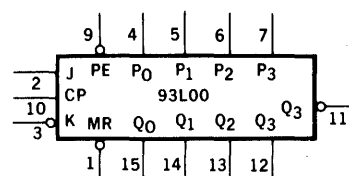

V_{CC} = Pin 16
GND = Pin 8

**CONNECTION DIAGRAMS
DIP (TOP VIEW)**

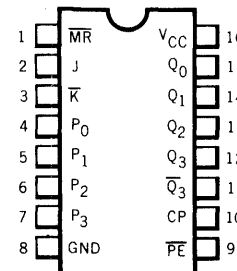

LOGIC DIAGRAM

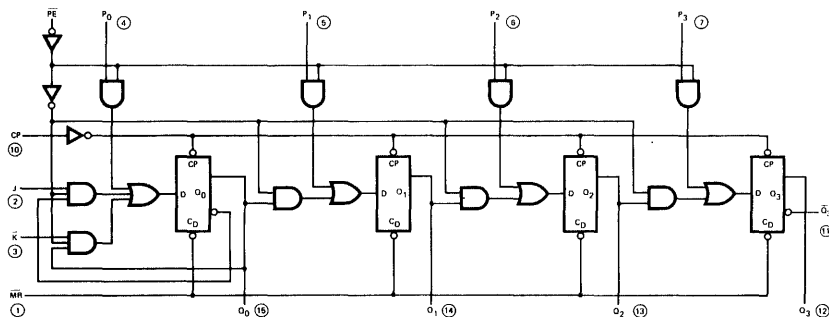

○ = PIN NUMBERS

FLATPAK (TOP VIEW)

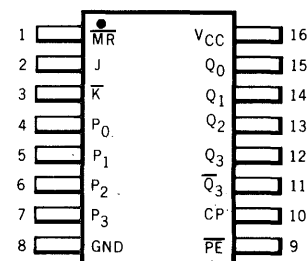

FUNCTIONAL DESCRIPTION — The logic diagram indicates the functional characteristics of the 93L00 4-bit shift register. Special logic features of the 93L00 design increase the versatility of this shift register.

1. A $J\bar{K}$ input is provided to the first flip-flop in the register. This type of input is the same as the more common JK input except that the LOW voltage level activates the \bar{K} input. This provides the greater power of the JK type input for most general applications. At the same time the simple D type input most appropriate for a shift register can be easily obtained by tying the two inputs together.
2. There is no restriction on the activity of the J or \bar{K} inputs for logic operation—except for the set up and release time requirements.
3. Parallel inputs for all four stages are provided. These will determine the next condition of the shift register synchronous with the clock input, whenever the parallel enable input is LOW. With the parallel enable input LOW, the element appears as four common clocked D flip-flops. When the parallel enable is HIGH, or not connected, the shift register performs a one bit shift for each clock input. In both cases the next state of the flip-flops occurs after the LOW to HIGH transition of the clock input.
4. An internal clock buffer provides both reduced clock input loading, and the ability to gate the clock with only a single NAND gate.
5. The active HIGH output is provided for all four stages and an active LOW output is provided for the last stage.
6. An asynchronous master reset input allows the setting to zero of all stages independent of any other input condition.

TRUTH TABLES

TABLE I — SERIAL ENTRY
(\overline{PE} = HIGH, \overline{MR} = HIGH)

J	\bar{K}	Q_0 at t_{n+1}
L	L	L
L	H	Q_0 at t_n (no change)
H	L	\bar{Q}_0 at t_n (toggles)
H	H	H

TABLE III — PARALLEL ENTRY
(\overline{PE} = LOW, \overline{MR} = HIGH)

D-Input (P_0, P_1, P_2 or P_3)	Output Q at t_{n+1} (Q_0, Q_1, Q_2 or Q_3)
L	L
H	H

(n+1 = Indicates state after next clock)

TABLE II — SERIAL ENTRY
(\overline{PE} = HIGH, \overline{MR} = HIGH)

J & \bar{K} Connected	Q_0 at t_{n+1}
L	L
H	H

TABLE IV — MODE SELECTION

	\overline{PE}	P_0	P_1	P_2	P_3	J	\bar{K}	\overline{MR}	
Serial Entry	H	X	X	X	X	Refer to Table I & II		H	
Parallel Entry	L	Refer to Table III				X	X		H

H = HIGH Voltage Level
L = LOW Voltage Level
X = Don't Care

TYPICAL INPUT AND OUTPUT CIRCUITS

INPUTS EQUIVALENT CIRCUIT

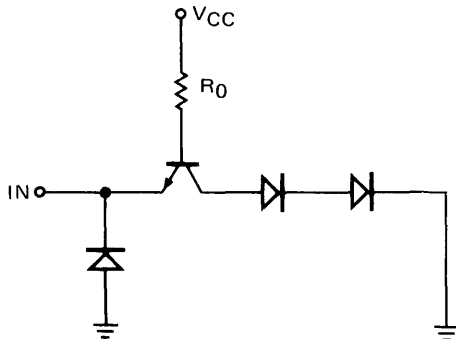

TYPICAL RESISTORS

- $R_0 = 16 \text{ k}\Omega$
- $R_1 = 6 \text{ k}\Omega$
- $R_2 = 240 \Omega$
- $R_3 = 5 \text{ k}\Omega$

OUTPUTS EQUIVALENT CIRCUIT

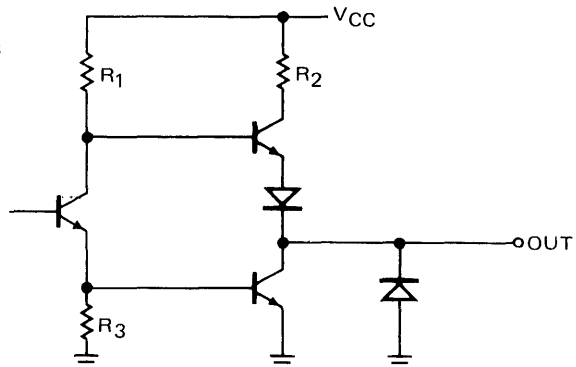

FAIRCHILD LPTTL/MSI • 93L00

ABSOLUTE MAXIMUM RATINGS (above which the useful life may be impaired)

Storage Temperature	-65°C to +150°C
Temperature (Ambient) Under Bias	-55°C to +125°C
V _{CC} Pin Potential to Ground Pin	-0.5 V to +7.0 V
*Input Voltage (dc)	-0.5 V to +5.5 V
*Input Current (dc)	-30 mA to +5.0 mA
Voltage Applied to Outputs (Output HIGH)	-0.5 V to +V _{CC} value
Output Current (dc) (Output LOW)	+30 mA

*Either Input Voltage limit or Input Current limit is sufficient to protect the inputs.

GUARANTEED OPERATING RANGES

PART NUMBER	SUPPLY VOLTAGE (V _{CC})			TEMPERATURE
	MIN.	TYP.	MAX.	
93L00XM	4.5 V	5.0 V	5.5 V	-55°C to 125°C
93L00XC	4.75 V	5.0 V	5.25 V	0°C to 75°C

X = package type; F for Flatpak, D for Ceramic Dip, P for Plastic Dip. See Packaging Information Section for packages available on this product.

ELECTRICAL CHARACTERISTICS OVER OPERATING TEMPERATURE RANGE (unless otherwise noted)

SYMBOL	PARAMETER	LIMITS			UNITS	CONDITIONS
		MIN.	TYP. (Note 4)	MAX.		
V _{OH}	Output HIGH Voltage	2.4	3.6		Volts	V _{CC} = MIN., I _{OH} = -0.32 mA V _{IN} = V _{IH} or V _{IL} per Truth Table
V _{OL}	Output LOW Voltage		0.1	0.3	Volts	V _{CC} = MIN., I _{OL} = 3.2 mA V _{IN} = V _{IH} or V _{IL} per Truth Table
V _{IH}	Input HIGH Voltage	2.0			Volts	Guaranteed Input HIGH Threshold Voltage for All Inputs
V _{IL}	Input LOW Voltage			0.7	Volts	Guaranteed Input LOW Threshold Voltage for All Inputs
I _{IL}	Input LOW Current J, \bar{K} , \overline{MR} , P ₀ , P ₁ , P ₂ & P ₃ CP PE		-0.25 -0.50 -0.58	-0.40 -0.80 -0.92	mA	V _{CC} = MAX., V _{IN} = 0.3 V
I _{IH}	Input HIGH Current J, \bar{K} , \overline{MR} , P ₀ , P ₁ , P ₂ & P ₃ CP PE		2.0 4.0 5.0	20 40 46	μA	V _{CC} = MAX., V _{IN} = 2.4 V
	Input HIGH Current			1.0	mA	V _{CC} = MAX., V _{IN} = 5.5 V
I _{SC} (Note 5)	Output Short Circuit Current	-2.5	-16	-25	mA	V _{CC} = MAX., V _{OUT} = 0 V
I _{CC}	Power Supply Current		15	23	mA	V _{CC} = MAX.

NOTES:

1. The actual testing procedures used to guarantee the Electrical Characteristics are contained in a detailed Customer Sample Specification. A copy of this specification can be obtained from Fairchild Digital Product Marketing, Mountain View, California.
2. Conditions for testing, not shown in the table, are chosen to guarantee operation under "worst case" conditions.
3. The specified LIMITS represent the "worst case" value for the parameter. Since these "worst case" values normally occur at the temperature and supply voltage extremes, additional noise immunity and guard banding can be achieved by decreasing the allowable system operating ranges.
4. Typical limits are at V_{CC} = 5.0 V, 25°C, and maximum loading.
5. Not more than one output should be shorted at a time.

SWITCHING CHARACTERISTICS (T_A = 25°C)

SYMBOL	PARAMETER	LIMITS			UNITS	CONDITIONS
		MIN	TYP	MAX		
f _{sr}	Shift Right Frequency	10	17		MHz	V _{CC} = 5.0 V, C _L = 15 pF (See Fig. 1c)
t _{PLH}	Turn Off Delay		23	35	ns	V _{CC} = 5.0 V, C _L = 15 pF (See Fig. 1a)
t _{PHL}	Turn On Delay		34	51	ns	
t _{PHL} (\overline{MR})	Reset Time for \overline{MR}		55	83	ns	

SWITCHING SET-UP REQUIREMENTS (T_A = 25°C)

SYMBOL	PARAMETER	LIMITS			UNITS	CONDITIONS
		MIN	TYP	MAX		
t _{pwCP}	Clock Pulse Width	38	25		ns	Fig. 1c
t _s	Set-up Time	60	35		ns	Fig. 1a
t _h	Hold Time	0	-22		ns	
t _s (\overline{PE})	Set-up Time for \overline{PE}	68	45		ns	Fig. 1b
t _h (\overline{PE})	Hold Time for \overline{PE}	-20	-39		ns	
t _{rec} (\overline{MR})	Recovery Time for \overline{MR}	70	45		ns	Fig. 1a
t _{pw} \overline{MR}	Min Reset Pulse Width	53	35		ns	

SET-UP TIME: t_s is defined as the minimum time required for the logic level to be present at the logic input prior to the clock transition from LOW to HIGH in order for the flip-flop(s) to respond.

HOLD TIME (t_h) is defined as the minimum time following the clock transition from LOW to HIGH that the logic level must be maintained at the input in order to insure continued recognition. A negative HOLD TIME indicates that the correct logic level may be released prior to the clock transition from LOW to HIGH and still be recognized.

RECOVERY TIME FOR MR: t_{rec}(\overline{MR}) is defined as the minimum time required between the end of the reset pulse and the clock transition from LOW to HIGH in order for the flip-flop(s) to respond to the clock.

Fig. 1a

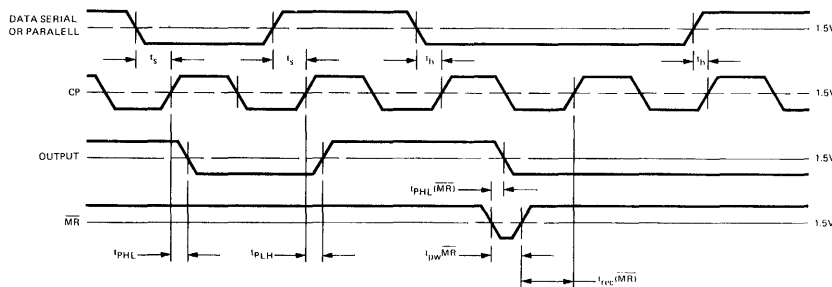

Fig. 1b

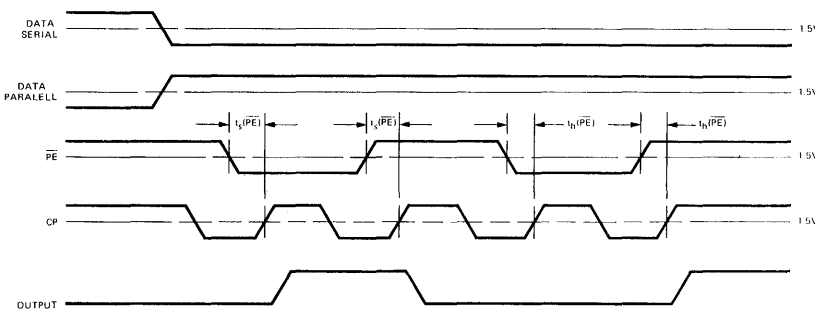
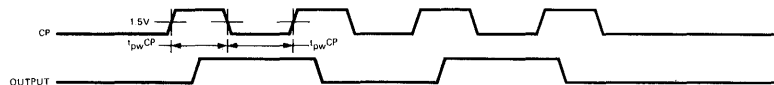

Fig. 1c



V_{OUT} Frequency = 1/2 X V_{IN} Frequency
 J = HIGH, \overline{R} = LOW, \overline{PE} = HIGH, \overline{MR} = HIGH

Fig. 1 SWITCHING TIME & SHIFT RIGHT FREQUENCY WAVEFORM

TTL/MSI 93S00

4-BIT UNIVERSAL SHIFT REGISTER

TO BE ANNOUNCED

DESCRIPTION — The 93S00 is a TTL/MSI super high speed 4-Bit Universal Shift Register. It utilizes Schottky clamped diode technology to achieve its super high speeds. As a high speed multi-functional sequential logic block, it is useful in a wide variety of register and counter applications. It may be used in serial-serial, shift left, shift right, serial-parallel, parallel-serial, and parallel-parallel data register transfers.

- TYPICAL SHIFT RIGHT FREQUENCY OF 100 MHz
- ASYNCHRONOUS COMMON RESET
- J, \bar{K} INPUTS TO FIRST STAGE
- SYNCHRONOUS PARALLEL ENTRY
- INPUT CLAMP DIODES LIMIT HIGH SPEED TERMINATION EFFECTS

PIN NAMES

\overline{PE}	Parallel Enable (Active LOW) Input
P_0, P_1, P_2, P_3	Parallel Inputs
J	First Stage J (Active HIGH) Input
\bar{K}	First Stage K (Active LOW) Input
CP	Clock (Active HIGH) Going Edge Input
\overline{MR}	Master Reset (Active LOW) Input
Q_0, Q_1, Q_2, Q_3	Parallel Outputs
$\overline{Q_3}$	Complementary Last Stage Output

LOGIC SYMBOL

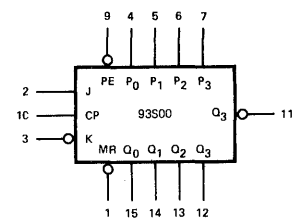

V_{CC} = Pin 16
GND = Pin 8

**CONNECTION DIAGRAMS
DIP (TOP VIEW)**

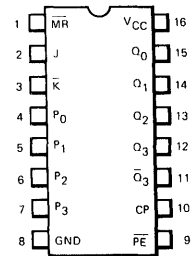

FLATPAK (TOP VIEW)

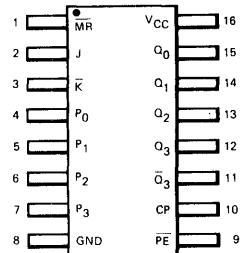

LOGIC DIAGRAM

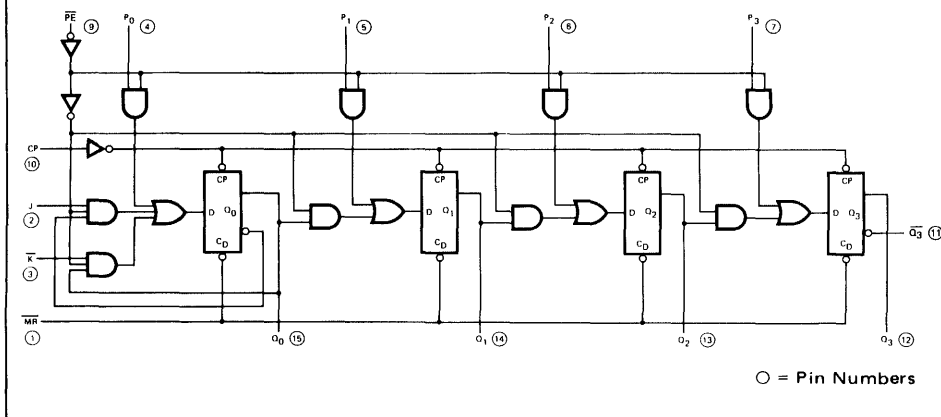

TTL/MSI 9301

ONE-OF-TEN DECODER

DESCRIPTION — The 9301 is a Multipurpose Decoder designed to accept four inputs and provide 10 mutually exclusive outputs. The circuit uses TTL for high speed and high fan out capability, and is compatible with all members of the Fairchild TTL family.

- MULTI-FUNCTION CAPABILITY
- MUTUALLY EXCLUSIVE OUTPUTS
- GUARANTEED FANOUT OF 10 TTL LOADS OVER THE FULL TEMPERATURE RANGE AND SUPPLY VOLTAGE RANGES
- HIGH CAPACITIVE DRIVE CAPABILITY
- DEMULTIPLEXING CAPABILITY
- TYPICAL POWER DISSIPATION OF 145 mW
- THE INPUT/OUTPUT CHARACTERISTICS PROVIDE EASY INTERFACING WITH FAIRCHILD DTL, LPDTL AND TTL FAMILIES
- ALL CERAMIC "HERMETIC" 16 LEAD DUAL IN-LINE PACKAGE
- INPUT CLAMP DIODES LIMIT HIGH SPEED LINE TERMINATION EFFECTS

PIN NAMES

A_0, A_1, A_2, A_3 Address Inputs
 $\bar{0}$ to $\bar{9}$ Outputs, Active LOW (Note b)

LOADING

(Note a)
 1 U.L.
 10 U.L.

NOTES:

- a. Unit Load (U.L.) = 40 μ A HIGH/1.6mA LOW
 b. 10 U.L. is the output LOW drive factor and 20 U.L. is the output HIGH drive factor.

LOGIC SYMBOL

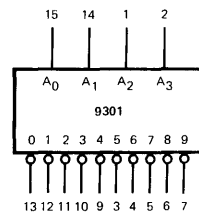

V_{CC} = Pin 16
 GND = Pin 8

CONNECTION DIAGRAMS DIP (TOP VIEW)

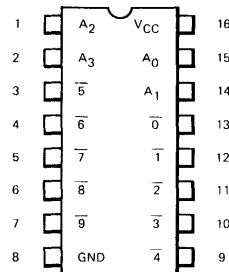

FLATPAK (TOP VIEW)

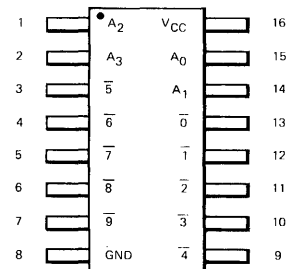

LOGIC DIAGRAM

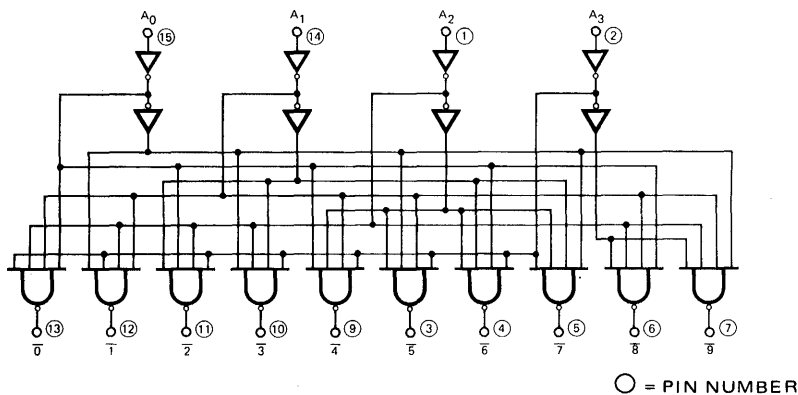

FUNCTIONAL DESCRIPTION — The 9301 decoder accepts four active HIGH BCD inputs and provides ten mutually exclusive active LOW outputs, as shown by the logic symbol. The active LOW outputs facilitate addressing other MSI units with active LOW enables.

The logic design of the 9301 ensures that all outputs are HIGH when binary codes greater than nine are applied to the inputs.

The most significant A_3 input produces a useful inhibit function when the 9301 is used as a 1 of 8 decoder.

TRUTH TABLE

A ₀	A ₁	A ₂	A ₃	0	1	2	3	4	5	6	7	8	9
L	L	L	L	L	H	H	H	H	H	H	H	H	H
H	L	L	L	H	L	H	H	H	H	H	H	H	H
L	H	L	L	H	H	L	H	H	H	H	H	H	H
H	H	L	L	H	H	H	L	H	H	H	H	H	H
L	L	H	L	H	H	H	H	L	H	H	H	H	H
H	L	H	L	H	H	H	H	L	H	H	H	H	H
L	H	H	L	H	H	H	H	H	L	H	H	H	H
H	H	H	L	H	H	H	H	H	L	H	H	H	H
L	L	L	H	H	H	H	H	H	H	L	H	H	H
H	L	L	H	H	H	H	H	H	H	H	L	H	H
L	H	L	H	H	H	H	H	H	H	H	H	L	H
H	H	L	H	H	H	H	H	H	H	H	H	H	L
L	L	H	H	H	H	H	H	H	H	H	H	H	H
H	L	H	H	H	H	H	H	H	H	H	H	H	H
L	H	H	H	H	H	H	H	H	H	H	H	H	H
H	H	H	H	H	H	H	H	H	H	H	H	H	H

H = HIGH Voltage Level
L = LOW Voltage Level

SWITCHING PERFORMANCE

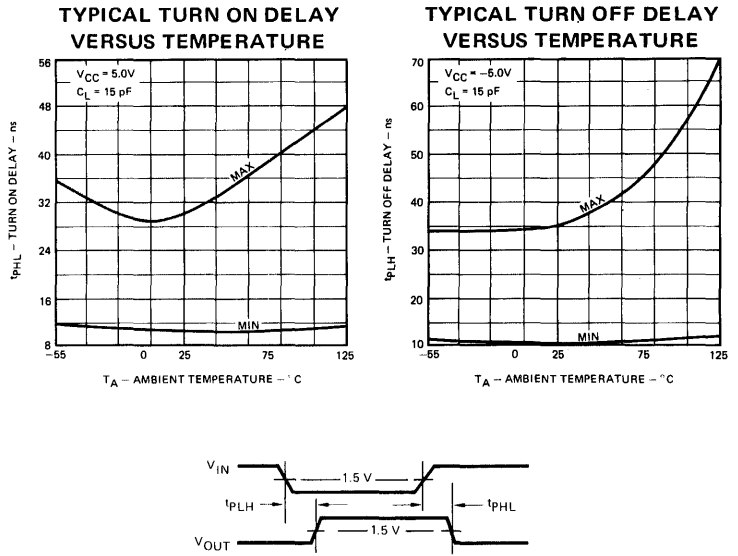
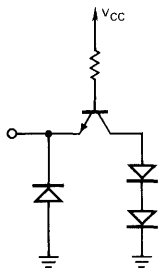

Fig. 1

TYPICAL INPUT AND OUTPUT CHARACTERISTICS

INPUT EQUIVALENT CIRCUIT



INPUT CURRENT VERSUS INPUT VOLTAGE

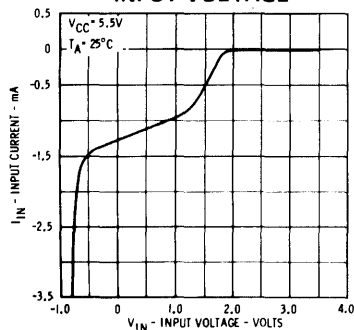
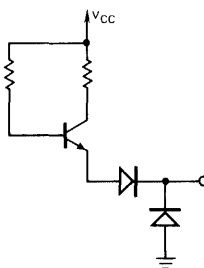

Fig. 2

OUTPUT EQUIVALENT CIRCUIT

OUTPUT HIGH



OUTPUT CURRENT VERSUS OUTPUT VOLTAGE OUTPUT HIGH

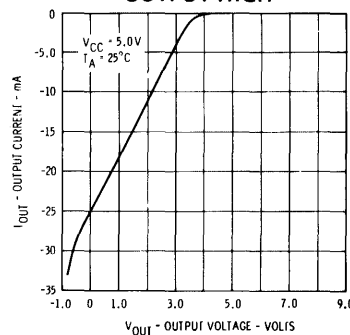
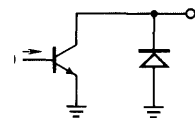

Fig. 3

OUTPUT LOW



OUTPUT CURRENT VERSUS OUTPUT VOLTAGE OUTPUT LOW

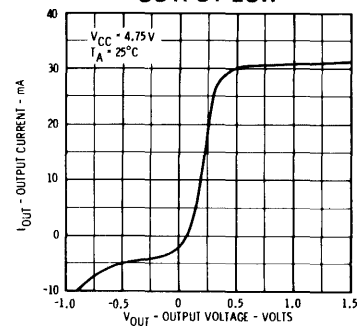

Fig. 4

ABSOLUTE MAXIMUM RATINGS (above which the useful life may be impaired)

Storage Temperature	-65°C to +150°C
Temperature (Ambient) Under Bias	-55°C to +125°C
V _{CC} Pin Potential to Ground Pin	-0.5V to +7.0V
*Input Voltage (dc)	-0.5V to +5.5V
*Input Current (dc)	-30 mA to +5.0 mA
Voltage Applied to Outputs (Output HIGH)	-0.5V to +V _{CC} value
Output Current (dc) (Output LOW)	+30 mA

*Either Input Voltage Limit or Input Current is sufficient to protect the inputs.

GUARANTEED OPERATING RANGES

PART NUMBER	SUPPLY VOLTAGE (V _{CC})			TEMPERATURE
	MIN.	TYP.	MAX.	
9301XM	4.5 V	5.0 V	5.5 V	-55°C to 125°C
9301XC	4.75 V	5.0 V	5.25 V	0°C to 75°C

X = package type; F for Flatpak, D for Ceramic Dip, P for Plastic Dip. See Packaging Information Section for packages available on this product.

ELECTRICAL CHARACTERISTICS OVER OPERATING TEMPERATURE RANGE (unless otherwise noted)

SYMBOL	PARAMETER	LIMITS			UNITS	CONDITIONS
		MIN.	TYP. (Note 4)	MAX.		
V _{IH}	Input HIGH Voltage	2.0			Volts	Guaranteed input HIGH Threshold Voltage for all Inputs
V _{IL}	Input LOW Voltage			0.8	Volts	Guaranteed input LOW Threshold Voltage for all Inputs
V _{CD}	Input Clamp Diode Voltage			-1.5	Volts	V _{CC} = MIN., I _{IN} = -12mA, T _A = 25°C
V _{OH}	Output HIGH Voltage	2.4	3.6		Volts	V _{CC} = MIN., I _{OH} = -800μA V _{IN} = V _{IH} or V _{IL} per Truth Table
V _{OL}	Output LOW Voltage		0.2	0.4	Volts	V _{CC} = MIN., I _{OL} = 16mA V _{IN} = V _{IH} or V _{IL} per Truth Table
I _{IH}	Input HIGH Current		10	40	μA	V _{CC} = MAX., V _{IN} = 2.4 V
				1.0	mA	V _{CC} = MAX., V _{IN} = 5.5 V
I _{IL}	Input LOW Current		-0.96	-1.6	mA	V _{CC} = MAX., V _{IN} = 0.4 V
I _{SC} (I _{OS})	Output Short Circuit Current (Note 5)	-20	-40	-70	mA	V _{CC} = MAX., V _{OUT} = 0.0 V
I _{CC}	Power Supply Current		29	44	mA	V _{CC} = MAX.

NOTES:

- (1) The actual testing procedures used to guarantee the Electrical Characteristics are contained in a detailed Customer Sample Specification. A copy of this specification can be obtained from Fairchild Digital Product Marketing, Mountain View, California.
- (2) Conditions for testing, not shown in the Table, are chosen to guarantee operation under "worst case" conditions.
- (3) The specified LIMITS represent the "worst case" value for the parameter. Since these "worst case" values normally occur at the temperature and supply voltage extremes, additional noise immunity and guard banding can be achieved by decreasing the allowable system operating ranges.
- (4) Typical limits are at V_{CC} = 5.0V, 25°C, and maximum loading.
- (5) Not more than one output should be shorted at a time.

SWITCHING CHARACTERISTICS (T_A = 25°C)

SYMBOL	PARAMETER	LIMITS			UNITS	TEST CONDITIONS
		MIN.	TYP.	MAX.		
t _{PLH}	Turn Off Delay Input to Output		23	35	ns	V _{CC} = 5.0V
t _{PHL}	Turn On Delay Input to Output		20	30	ns	C _L = 15pF (See Fig. 1)



LPTTL/MSI 93L01

LOW POWER ONE-OF-TEN DECODER

DESCRIPTION – The LPTTL/MSI 93L01 is a Multipurpose Decoder designed to accept four inputs and provide 10 mutually exclusive outputs. The circuit uses TTL technology and is compatible with the Fairchild TTL family.

- MULTI-FUNCTION CAPABILITY
- MUTUALLY EXCLUSIVE OUTPUTS
- DEMULTIPLEXING CAPABILITY
- TYPICAL PROPAGATION DELAY OF 63 ns
- TYPICAL POWER DISSIPATION OF 45 mW
- INPUT CLAMP DIODES LIMIT HIGH SPEED TERMINATION EFFECTS
- ALL CERAMIC "HERMETIC" 16-LEAD DUAL IN-LINE AND FLAT PACKAGES
- TTL COMPATIBLE

PIN NAMES

A_0, A_1, A_2, A_3 Address Inputs
 0 to 9 Outputs (Active LOW)

LOADING	
HIGH	LOW
0.5 U.L.	0.25 U.L.
10 U.L.	2.5 U.L.

1 Unit Load (U.L.) = 40 μ A HIGH/1.6 mA LOW

LOGIC SYMBOL

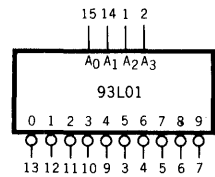

V_{CC} = PIN 16
 GND = PIN 8

**CONNECTION DIAGRAMS
 DIP (TOP VIEW)**

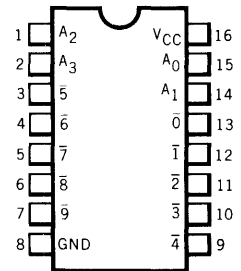

LOGIC DIAGRAM

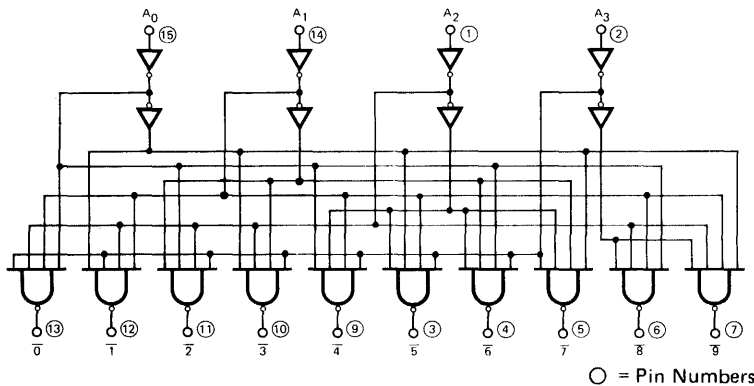

FLATPAK (TOP VIEW)

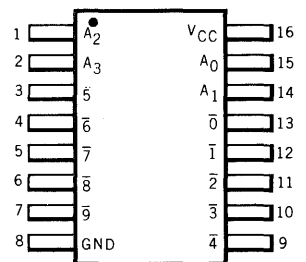

FAIRCHILD LPTTL/MSI • 93L01

FUNCTIONAL DESCRIPTION – The 93L01 decoder accepts four active HIGH BCD inputs and provides ten mutually exclusive active LOW outputs, as shown by logic symbol or diagram. The active LOW outputs facilitate addressing other MSI units with active LOW input enables.

The logic design of the 93L01 ensures that all outputs are HIGH when binary codes greater than nine are applied to the inputs.

The most significant input A₃ produces a useful inhibit function when the 93L01 is used as a 1-of-8 decoder.

TRUTH TABLE

A ₀	A ₁	A ₂	A ₃	0	1	2	3	4	5	6	7	8	9
L	L	L	L	L	H	H	H	H	H	H	H	H	H
H	L	L	L	H	L	H	H	H	H	H	H	H	H
L	H	L	L	H	H	L	H	H	H	H	H	H	H
H	H	L	L	H	H	H	L	H	H	H	H	H	H
L	L	H	L	H	H	H	H	L	H	H	H	H	H
H	L	H	L	H	H	H	H	H	L	H	H	H	H
L	H	H	L	H	H	H	H	H	H	L	H	H	H
H	H	H	L	H	H	H	H	H	H	H	L	H	H
L	L	L	H	H	H	H	H	H	H	H	H	L	H
H	L	L	H	H	H	H	H	H	H	H	H	H	L
L	H	L	H	H	H	H	H	H	H	H	H	H	H
H	H	L	H	H	H	H	H	H	H	H	H	H	H
L	L	H	H	H	H	H	H	H	H	H	H	H	H
H	L	H	H	H	H	H	H	H	H	H	H	H	H
L	H	H	H	H	H	H	H	H	H	H	H	H	H
H	H	H	H	H	H	H	H	H	H	H	H	H	H

H = HIGH Voltage Level
L = LOW Voltage Level

TYPICAL INPUT AND OUTPUT CIRCUITS

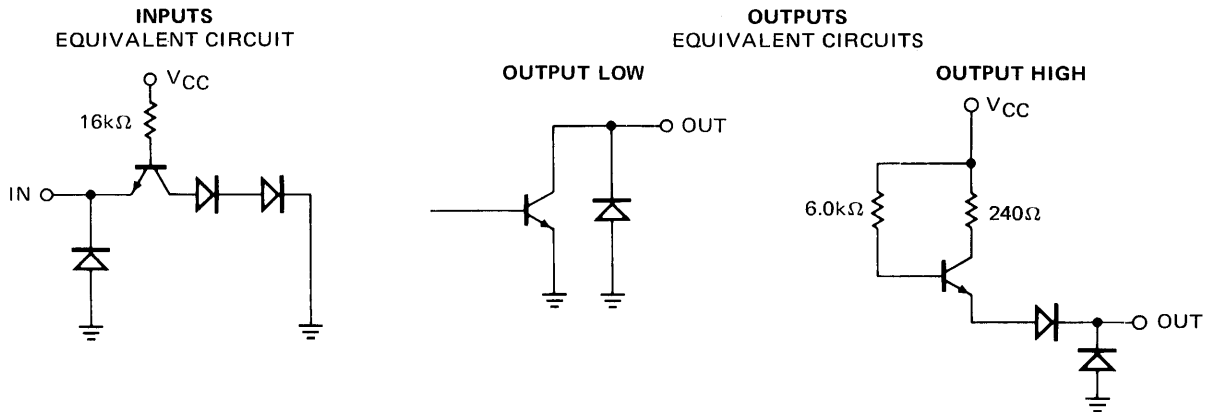

ABSOLUTE MAXIMUM RATINGS (above which the useful life may be impaired)

Storage Temperature	–65°C to +150°C
Temperature (Ambient) Under Bias	–55°C to +125°C
V _{CC} Pin Potential to Ground Pin	–0.5 V to +7.0 V
*Input Voltage (dc)	–0.5 V to +5.5 V
*Input Current (dc)	–30 mA to +5.0 mA
Voltage Applied to Outputs (Output HIGH)	–0.5 V to +V _{CC} value
Output Current (dc) (Output LOW)	+30 mA

*Either Input Voltage limit or Input Current limit is sufficient to protect the inputs.

FAIRCHILD LPTTL/MSI • 93L01

GUARANTEED OPERATING RANGES

PART NUMBER	SUPPLY VOLTAGE (V _{CC})			TEMPERATURE
	MIN.	TYP.	MAX.	
93L01XM	4.5 V	5.0 V	5.5 V	-55°C to 125°C
93L01XC	4.75 V	5.0 V	5.25 V	0°C to 75°C

X = package type; F for Flatpak, D for Ceramic Dip, P for Plastic Dip. See Packaging Information Section for packages available on this product.

ELECTRICAL CHARACTERISTICS OVER OPERATING TEMPERATURE RANGE (Unless Otherwise Noted)

SYMBOL	PARAMETER	LIMITS			UNITS	CONDITIONS
		MIN.	TYP. (Note 4)	MAX.		
V _{OH}	Output HIGH Voltage	2.4	3.6		Volts	V _{CC} = MIN., I _{OH} = -0.4 mA V _{IN} = V _{IH} or V _{IL} per Truth Table
V _{OL}	Output LOW Voltage		0.15	0.3	Volts	V _{CC} = MIN., I _{OL} = 4.0 mA V _{IN} = V _{IH} or V _{IL} per Truth Table
V _{IH}	Input HIGH Voltage	2.0			Volts	Guaranteed Input HIGH Threshold Voltage for All Inputs
V _{IL}	Input LOW Voltage			0.7	Volts	Guaranteed Input LOW Threshold Voltage for All Inputs
I _{IL}	Input LOW Current		-0.25	-0.4	mA	V _{CC} = MAX., V _{IN} = 0.3 V
I _{IH}	Input HIGH Current		2.0	20	μA	V _{CC} = MAX., V _{IN} = 2.4 V
				1.0	mA	V _{CC} = MAX., V _{IN} = 5.5 V
I _{SC}	Output Short Circuit Current	-2.5	-16	-25	mA	V _{CC} = MAX., V _{OUT} = 0.0 V (Note 5)
I _{CC}	Power Supply Current		9.0	13	mA	V _{CC} = MAX., Inputs at GND

NOTES:

1. The actual testing procedures used to guarantee the Electrical Characteristics are contained in a detailed Customer Sample Specification. A copy of this specification can be obtained from Fairchild Digital Product Marketing, Mountain View, California.
2. Conditions for testing, not shown in the table, are chosen to guarantee operation under "worst case" conditions.
3. The specified LIMITS represent the "worst case" value for the parameter. Since these "worst case" values normally occur at the temperature and supply voltage extremes, additional noise immunity and guard banding can be achieved by decreasing the allowable system operating ranges.
4. Typical limits are at V_{CC} = 5.0 V, 25°C, and maximum loading.
5. Not more than one output should be shorted at a time.

SWITCHING CHARACTERISTICS (T_A = 25°C)

SYMBOL	PARAMETER	LIMITS			UNITS	CONDITIONS
		MIN.	TYP.	MAX.		
t _{PLH}	Turn Off Delay Input to Output		32	50	ns	V _{CC} = 5.0 V See Fig. 1 C _L = 15 pF
t _{PHL}	Turn On Delay Input to Output		36	55	ns	

SWITCHING TIME WAVEFORMS

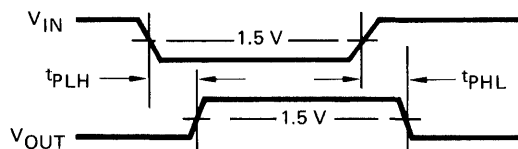

Fig. 1

TTL/MSI 9302

ONE-OF-TEN DECODER WITH OPEN COLLECTOR OUTPUT

DESCRIPTION — The 9302 is a multipurpose Decoder designed to accept four inputs and provide 10 mutually exclusive outputs. The open collector outputs provide wired-OR capability which can be used for numerous summing, decoding and demultiplexing operations. The circuit uses TTL for high speed and high fan out capability, and is compatible with all members of the Fairchild TTL family.

- **OUTPUTS HAVE WIRED-OR CAPABILITY**
- **PROVIDES CAPABILITY TO GENERATE AND SUM MINTERMS OF 3 OR 4 VARIABLES**
- **ACTIVE LOW OUTPUTS ARE USEFUL FOR DRIVING LOW VOLTAGE LAMPS AND RELAYS**
- **MULTI-FUNCTION CAPABILITY**
- **MUTUALLY EXCLUSIVE OUTPUTS**
- **DEMULPLEXING CAPABILITY**
- **TYPICAL POWER DISSIPATION OF 145 mW**
- **INPUT CLAMP DIODES LIMIT HIGH SPEED LINE TERMINATION EFFECTS**

PIN NAMES

A_0, A_1, A_2, A_3 Address Inputs
 $\bar{0}$ to $\bar{9}$ Outputs, Active LOW (Note b)

LOADING

(Note a)
 1 U.L.
 10 U.L.

NOTES:

- a. Unit Load (U.L.) = 40 μ A HIGH/1.6mA LOW
 b. An external pull-up resistor is needed to provide HIGH level drive capability. The outputs will sink a maximum of 16mA at $V_{OUT} = 0.4$ V.

LOGIC DIAGRAM

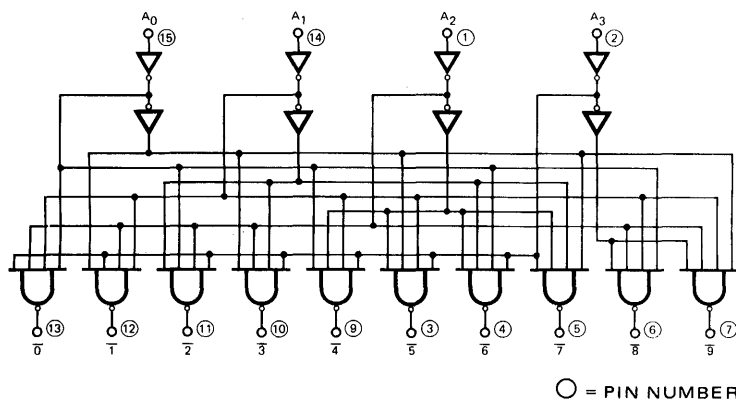

LOGIC SYMBOL

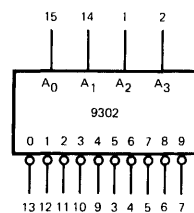

V_{CC} = Pin 16
 GND = Pin 8

**CONNECTION DIAGRAMS
 DIP (TOP VIEW)**

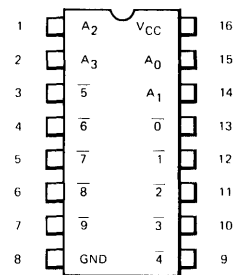

FLATPAK (TOP VIEW)

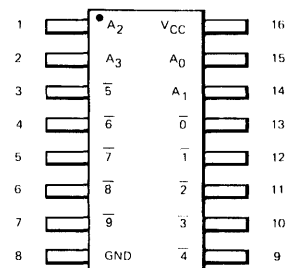

FAIRCHILD TTL/MSI • 9302

FUNCTIONAL DESCRIPTION – The 9302 decoder accepts four active HIGH BCD inputs and provides ten mutually exclusive active LOW outputs, as shown by the logic symbol. The open collector outputs provide easy summing of input terms. The 9302 provides the capability in one package to generate and sum any or all of the minterms of three variables, or the first 10-of-16 minterms of four variables. The logic design of the 9302 ensures that all outputs are HIGH when binary codes greater than nine are applied to the inputs. The most significant input (A_3) produces a useful inhibit function when the 9302 is used as a 1-of-8 decoder.

TRUTH TABLE

A0	A1	A2	A3	0	1	2	3	4	5	6	7	8	9
L	L	L	L	L	H	H	H	H	H	H	H	H	H
H	L	L	L	H	L	H	H	H	H	H	H	H	H
L	H	L	L	H	H	L	H	H	H	H	H	H	H
H	H	L	L	H	H	H	L	H	H	H	H	H	H
L	L	H	L	H	H	H	H	L	H	H	H	H	H
H	L	H	L	H	H	H	H	H	L	H	H	H	H
L	H	H	L	H	H	H	H	H	H	L	H	H	H
H	H	H	L	H	H	H	H	H	H	H	L	H	H
L	L	L	H	H	H	H	H	H	H	H	H	L	H
H	L	L	H	H	H	H	H	H	H	H	H	H	L
L	H	L	H	H	H	H	H	H	H	H	H	H	H
H	H	L	H	H	H	H	H	H	H	H	H	H	H
L	L	H	H	H	H	H	H	H	H	H	H	H	H
H	L	H	H	H	H	H	H	H	H	H	H	H	H
L	H	H	H	H	H	H	H	H	H	H	H	H	H
H	H	H	H	H	H	H	H	H	H	H	H	H	H

H = HIGH Voltage Level
L = LOW Voltage Level

TYPICAL INPUT AND OUTPUT CHARACTERISTICS

INPUT EQUIVALENT CIRCUIT

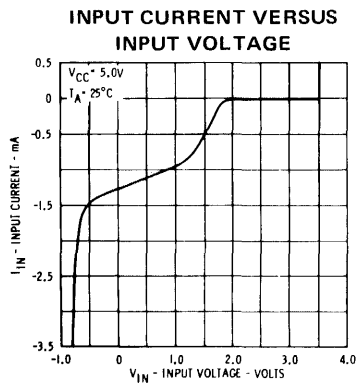
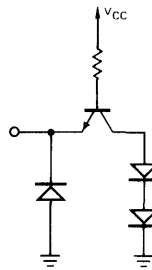

OUTPUT EQUIVALENT CIRCUIT

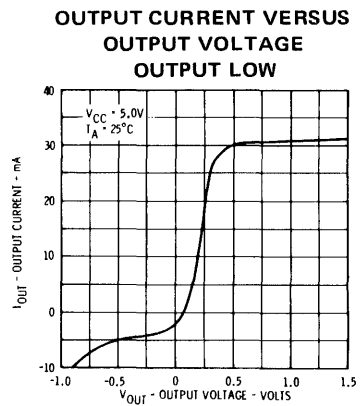
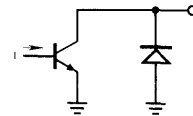

FAIRCHILD TTL/MSI • 9302

ABSOLUTE MAXIMUM RATINGS (above which the useful life may be impaired)

Storage Temperature	-65°C to +150°C
Temperature (Ambient) Under Bias	-55°C to +125°C
V _{CC} Pin Potential to Ground Pin	-0.5V to +7.0V
*Input Voltage (dc)	-0.5V to +5.5V
*Input Current (dc)	-30 mA to +5.0 mA
Voltage Applied to Outputs (Output HIGH)	-0.5V to +V _{CC} value
Output Current (dc) (Output LOW)	+30 mA

*Either Input Voltage Limit or Input Current is sufficient to protect the inputs.

GUARANTEED OPERATING RANGES

PART NUMBER	SUPPLY VOLTAGE (V _{CC})			TEMPERATURE
	MIN.	TYP.	MAX.	
9302XM	4.5 V	5.0 V	5.5 V	-55°C to 125°C
9302XC	4.75 V	5.0 V	5.25 V	0°C to 75°C

X = package type; F for Flatpak, D for Ceramic Dip, P for Plastic Dip. See Packaging Information Section for packages available on this product.

ELECTRICAL CHARACTERISTICS OVER OPERATING TEMPERATURE RANGE (unless otherwise noted)

SYMBOL	PARAMETER	LIMITS			UNITS	CONDITIONS
		MIN.	TYP. (Note 4)	MAX.		
V _{IH}	Input HIGH Voltage	2.0			Volts	Guaranteed input HIGH Threshold Voltage for all Inputs
V _{IL}	Input LOW Voltage			0.8	Volts	Guaranteed input LOW Threshold Voltage for all Inputs
V _{CD}	Input Clamp Diode Voltage			-1.5	Volts	V _{CC} = MIN., I _{IN} = -12mA, T _A = 25°C
I _{CEX}	Output HIGH Leakage Current			250	μA	V _{CC} = MIN., V _{CEX} = 5.5 V V _{IN} = V _{IH} or V _{IL} per Truth Table
V _{OL}	Output LOW Voltage		0.2	0.4	Volts	V _{CC} = MIN., I _{OL} = 16mA V _{IN} = V _{IH} or V _{IL} per Truth Table
I _{IH}	Input HIGH Current		10	40	μA	V _{CC} = MAX., V _{IN} = 2.4 V
I _{IL}	Input LOW Current		-0.96	-1.6	mA	V _{CC} = MAX., V _{IN} = 0.4 V
I _{CC}	Power Supply Current		29		mA	V _{CC} = MAX.

NOTES:

- (1) The actual testing procedures used to guarantee the Electrical Characteristics are contained in a detailed Customer Sample Specification. A copy of this specification can be obtained from Fairchild Digital Product Marketing, Mountain View, California.
- (2) Conditions for testing, not shown in the Table, are chosen to guarantee operation under "worst case" conditions.
- (3) The specified LIMITS represent the "worst case" value for the parameter. Since these "worst case" values normally occur at the temperature and supply voltage extremes, additional noise immunity and guard banding can be achieved by decreasing the allowable system operating ranges.
- (4) Typical limits are at V_{CC} = 5.0V, 25°C, and maximum loading.

TTL/MSI 9304

DUAL FULL ADDER

DESCRIPTION — The 9304 consists of two independent, high speed, binary Full Adders. The adders are useful in a wide variety of applications including multiple bit parallel add/serial carry addition, parity generation and checking, code conversion and majority gating. The circuit uses TTL for high speed, high fanout operation and is compatible with all members of the Fairchild TTL family.

- **MULTI-FUNCTION CAPABILITY**
- **8ns CARRY PROPAGATION DELAY**
- **COMPLEMENTARY INPUTS AND OUTPUTS AVAILABLE**
- **TYPICAL POWER DISSIPATION OF 150 mW**
- **THE INPUT/OUTPUT CHARACTERISTICS PROVIDE EASY INTERFACING WITH FAIRCHILD DTL, LPDTL AND TTL FAMILIES**
- **ALL CERAMIC "HERMETIC" 16-LEAD DUAL IN-LINE PACKAGE**
- **INPUT CLAMP DIODES LIMIT HIGH SPEED TERMINATION EFFECTS**

PIN NAMES

FULL ADDER 1	
A, B	Operand Inputs
C	Carry Input
S	Sum Output (Note c)
\bar{S}	Complementary Sum Output (Note c)
\bar{C}_0	Carry (Active LOW) Output (Note b)
FULL ADDER 2	
A ₁ , B ₁	OR Operand (Active HIGH) Input
\bar{A}_2 , \bar{B}_2	OR Operand (Active LOW) Input
\bar{C}	Carry (Active LOW) Input
S	Sum Output (Note c)
\bar{S}	Complementary Sum Output (Note c)
C ₀	Carry (Active HIGH) Output (Note b)

LOADING

(Note a)

4 U.L.
4 U.L.
10 U.L.
10 U.L.
7 U.L.
1 U.L.
4 U.L.
4 U.L.
10 U.L.
10 U.L.
7 U.L.

NOTES:

- 1 Unit Load (U.L.) = 40 μ A HIGH/1.6mA LOW.
- 7 U.L. is the output LOW drive factor and 14 U.L. is the output HIGH drive factor.
- 10 U.L. is the output LOW drive factor and 20 U.L. is the output HIGH drive factor.

LOGIC SYMBOL

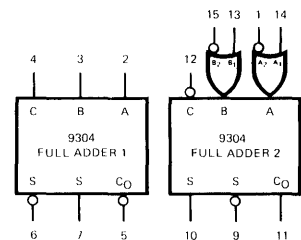

V_{CC} = Pin 16
GND = Pin 8

CONNECTION DIAGRAMS

DIP (TOP VIEW)

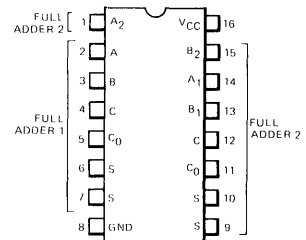

FLATPAK (TOP VIEW)

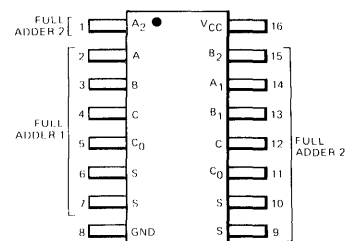

LOGIC DIAGRAM

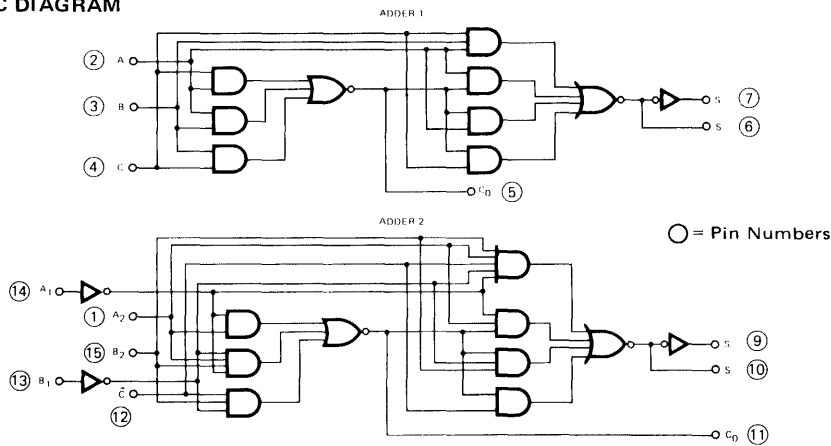

FUNCTIONAL DESCRIPTION — The Fairchild 9304 logic block consists of two separate high speed carry dependent sum full adders. This design allows a minimum carry propagation time when the adders are used in ripple carry applications. The adders are identical except that adder 2 has provision for either active HIGH or active LOW inputs at the A and B terminals. The adders produce a LOW carry and both LOW and HIGH sum with active HIGH inputs, a HIGH carry and both HIGH and LOW sum when active LOW inputs are used. This principle of duality is shown below, where the adders are drawn as functional blocks.

TRUTH TABLES

ADDER 1			ADDER 2		
INPUTS			OUTPUTS		
C	B	A	\bar{C}_0	\bar{S}	S
L	L	L	H	H	L
L	L	H	H	L	H
L	H	L	H	L	H
L	H	H	L	H	L
H	L	L	H	L	H
H	L	H	L	H	L
H	H	L	L	H	L
H	H	H	L	L	H

ADDER 2			ADDER 1				
INPUTS					OUTPUTS		
\bar{C}	B_1	A_1	\bar{B}_2	\bar{A}_2	C_0	S	\bar{S}
L	L	L	L	L	H	H	L
L	L	L	L	H	H	L	H
L	L	L	H	L	H	L	H
L	L	L	H	H	L	H	L
L	L	H	L	L	H	H	L
L	L	H	L	H	H	H	L
L	L	H	H	L	H	L	H
L	L	H	H	H	H	L	H
L	H	L	L	L	H	H	L
L	H	L	L	H	H	L	H
L	H	L	H	L	H	H	L
L	H	L	H	H	H	L	H
L	H	H	L	L	H	H	L
L	H	H	L	H	H	H	L
L	H	H	H	L	H	H	L
L	H	H	H	H	H	H	L
H	L	L	L	L	H	L	H
H	L	L	L	H	L	H	L
H	L	L	H	L	L	L	H
H	L	L	H	H	H	L	H
H	L	H	L	L	L	H	L
H	L	H	L	H	L	H	L
H	L	H	H	L	L	L	H
H	L	H	H	H	L	H	L
H	H	L	L	L	H	L	H
H	H	L	L	H	L	H	L
H	H	L	H	L	H	L	H
H	H	L	H	H	L	H	L
H	H	H	L	L	H	L	H
H	H	H	L	H	H	L	H
H	H	H	H	L	H	L	H
H	H	H	H	H	H	L	H

H = HIGH Voltage Level
L = LOW Voltage Level

FUNCTIONAL BLOCK REPRESENTATION

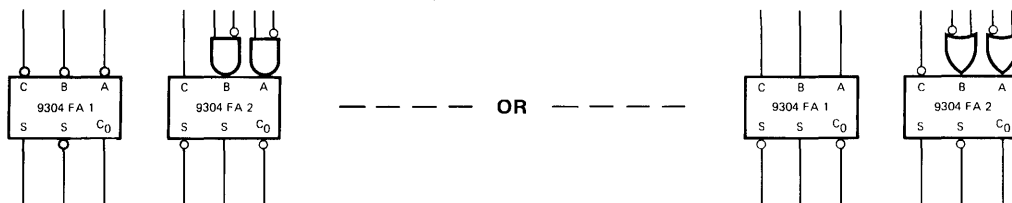

FAIRCHILD TTL/MSI • 9304

ABSOLUTE MAXIMUM RATINGS (above which the useful life may be impaired)

Storage Temperature	-65°C to +150°C
Temperature (Ambient) Under Bias	-55°C to +125°C
V _{CC} Pin Potential to Ground Pin	-0.5V to +7.0V
*Input Voltage (dc)	-0.5V to +5.5V
*Input Current (dc)	-30mA to +5.0mA
Voltage Applied to Outputs (Output HIGH)	-0.5V to +V _{CC} value
Output Current (dc) (Output LOW)	+30mA

*Either Input Voltage Limit or Input Current is sufficient to protect the inputs.

GUARANTEED OPERATING RANGES

PART NUMBERS	SUPPLY VOLTAGE			TEMPERATURE
	MIN.	TYP.	MAX.	
9304XM	4.5 V	5.0 V	5.5 V	-55°C to 125°C
9304XC	4.75 V	5.0 V	5.25 V	0°C to 75°C

X = package type; F for Flatpak, D for Ceramic Dip, P for Plastic Dip. See Packaging Information Section for packages available on this product.

ELECTRICAL CHARACTERISTICS OVER OPERATING TEMPERATURE RANGE (unless otherwise noted)

SYMBOL	PARAMETER	LIMITS			UNITS	CONDITIONS
		MIN	TYP	MAX		
V _{IH}	Input HIGH Voltage	2.0			Volts	Guaranteed Input HIGH Threshold Voltage For All Inputs
V _{IL}	Input LOW Voltage			0.8	Volts	Guaranteed Input LOW Threshold Voltage For All Inputs
V _{CD}	Input Clamp Diode Voltage			-1.5	Volts	V _{CC} = MIN., I _{IN} = -12 mA, T _A = 25°C
V _{OH}	Output HIGH Voltage	2.4	3.6		Volts	I _{OH} = -560µA (Pins 5 & 11) V _{CC} = MIN., I _{OH} = -800µA V _{IN} = V _{IH} or V _{IL} per Truth Table
V _{OL}	Output LOW Voltage		0.2	0.4	Volts	I _{OL} = 11.2mA (Pins 5 & 11) V _{CC} = MIN., I _{OL} = 16mA V _{IN} = V _{IH} or V _{IL} per Truth Table
I _{IH}	Input HIGH Current A ₁ & B ₁ (Pins 14 & 13) Other Inputs		10 40	40 160	µA	V _{CC} = MAX., V _{IN} = 2.4 V
	Input HIGH Current All Inputs			1.0	mA	V _{CC} = MAX., V _{IN} = 5.0 V
I _{IL}	Input LOW Current A ₁ & B ₁ (Pins 14 & 13) Other Inputs		-0.96 -3.84	-1.6 -6.4	mA	V _{CC} = MAX., V _{IN} = 0.4 V
	Output Short Circuit Current (Note 5)	-30	-60	-100	mA	V _{CC} = MAX., V _{OUT} = 0.0 V
I _{CC}	Power Supply Current			55	mA	V _{CC} = MAX., Pins 13 & 14 = 0.0 V

NOTES:

- The actual testing procedures used to guarantee the Electrical Characteristics are contained in a detailed Customer Sample Specification. A copy of this specification can be obtained from Fairchild Digital Product Marketing, Mountain View, California
- Conditions for testing, not shown in the Table, are chosen to guarantee operation under "worst case" conditions.
- The specified LIMITS represent the "worst case" value for the parameter. Since these "worst case" values normally occur at the temperature and supply voltage extremes, additional noise immunity and guard banding can be achieved by decreasing the allowable system operating ranges.
- Typical limits are at V_{CC} = 5.0V, 25°C, and maximum loading.
- Not more than one output should be shorted at a time.

SWITCHING CHARACTERISTICS (T_A = 25°C)

SYMBOL	PARAMETERS	9304XM			9304XC			UNITS	TEST CONDITIONS
		MIN.	TYP.	MAX.	MIN.	TYP.	MAX.		
t _{PLH}	Turn Off Delay Input to Output A ₁ to \bar{S}		28	40		28	45	ns	V _{CC} = 5.0 V
t _{PHL}	Turn On Delay Input to Output A ₁ to \bar{S}		25	35		25	40	ns	C _L = 15pF See Fig. B

TYPICAL INPUT AND OUTPUT CHARACTERISTICS

INPUTS
EQUIVALENT CIRCUIT

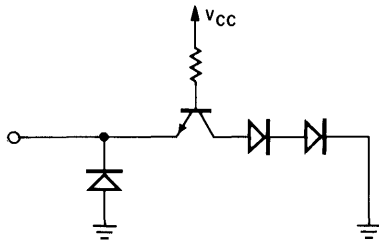

OUTPUTS
EQUIVALENT CIRCUIT

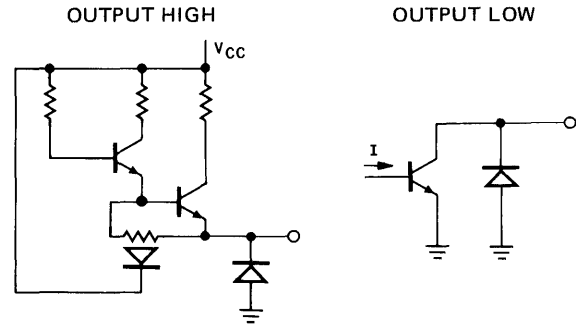

INPUT CURRENT VERSUS INPUT VOLTAGE

PINS 1, 2, 3, 4, 12, 15

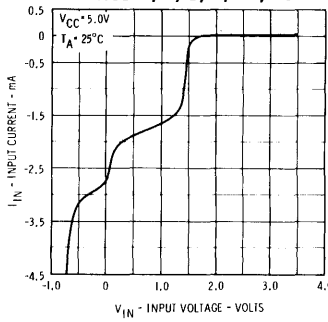

PINS 13, 14

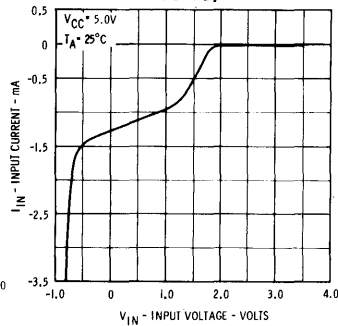

OUTPUT CURRENT VERSUS OUTPUT VOLTAGE

HIGH STATE

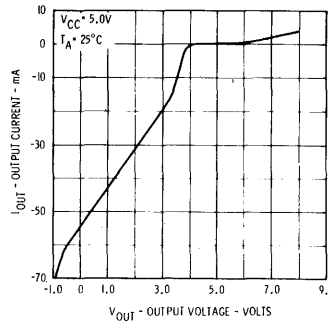

LOW STATE

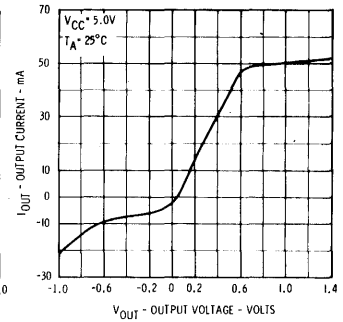
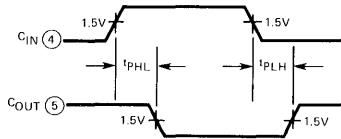
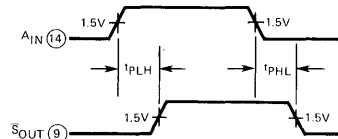

Fig. A

SWITCHING CHARACTERISTICS



Note: ○ = PIN NUMBER



TYPICAL CARRY TURN ON
DELAY TIME
VERSUS TEMPERATURE

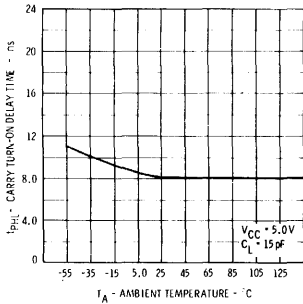

TYPICAL CARRY TURN OFF
DELAY TIME
VERSUS TEMPERATURE

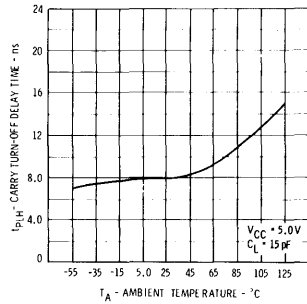

TYPICAL ADD TURN ON
DELAY TIME
VERSUS TEMPERATURE

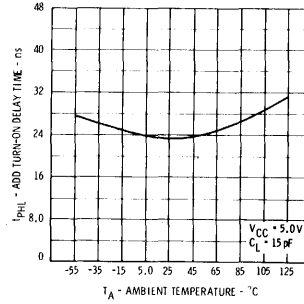

TYPICAL ADD TURN OFF
DELAY TIME
VERSUS TEMPERATURE

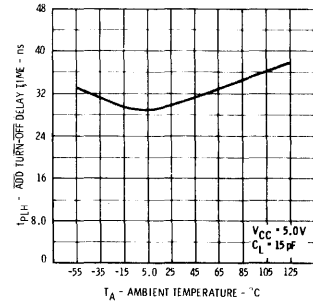

Fig. B

TTL/MSI 9305

VARIABLE MODULO COUNTER

DESCRIPTION – The TTL/MSI 9305 is a monolithic, high speed, Variable Modulo Counter circuit, constructed with the Fairchild Planar* epitaxial process. It is a semisynchronous counter which can be programmed without extra logic to provide division or counting by either 2 and 4, 5, 6, 7, 8, or 10, 12, 14, 16. A binary count sequence can be obtained for all of the preceding counter modulus as well as 50% duty cycle output for dividers of 8, 10, 12, 14, 16. The device also features asynchronous overriding master reset and set inputs and the negation output of the final flip-flop output which allows the cascading of stages. The circuit uses TTL for high speed, high fanout operation and is compatible with all other members of the TTL family of digital integrated circuits.

- **VARIOUS BINARY COUNTING MODES**
 - MODULO 2 AND MODULO 5, 6, 7, 8
 - MODULO 10 (8421 BCD), 12, 14, 16
- **VARIOUS FREQUENCY DIVISION MODES WITH 50% DUTY CYCLE OUTPUT**
 - MODULO 8, 10, 12, 14, 16
- **LOGIC SELECTION OF COUNTING MODE**
- **ASYNCHRONOUS MASTER RESET AND SET INPUTS**
- **MULTISTAGE COUNTING OPERATION**
- **TTL COMPATIBLE**
- **INPUT CLAMP DIODES LIMIT HIGH SPEED TERMINATION EFFECTS**

PIN NAMES

S_0, S_1	Select Inputs
CP_0	First Stage Clock Active HIGH Going Edge Input
CP_1	Three Stage Clock Active HIGH Going Edge Input
\overline{MS}	Master Set (Active LOW) Input
\overline{MR}	Master Reset (Active LOW) Input
Q_0	First Stage Output (Note b)
\overline{Q}_0	Complementary First Stage Output (Note b)
Q_1, Q_2, Q_3	Three Stage Counter Outputs (Note b)
\overline{Q}_3	Complementary Last Stage Output (Note c)

LOADING
(Note a)

Q_0	1 U.L.
\overline{Q}_0	1 U.L.
Q_1, Q_2, Q_3	1 U.L.
\overline{Q}_3	1 U.L.
Q_0	8 U.L.
\overline{Q}_0	8 U.L.
Q_1, Q_2, Q_3	8 U.L.
\overline{Q}_3	10 U.L.

NOTES:

- (a) 1 Unit Load (U.L.) = 40 μ A HIGH/1.6 mA LOW.
 (b) 8 U.L. is the output LOW drive factor and 16 U.L. is the output HIGH drive factor.
 (c) 10 U.L. is the output LOW drive factor and 20 U.L. is the output HIGH drive factor.

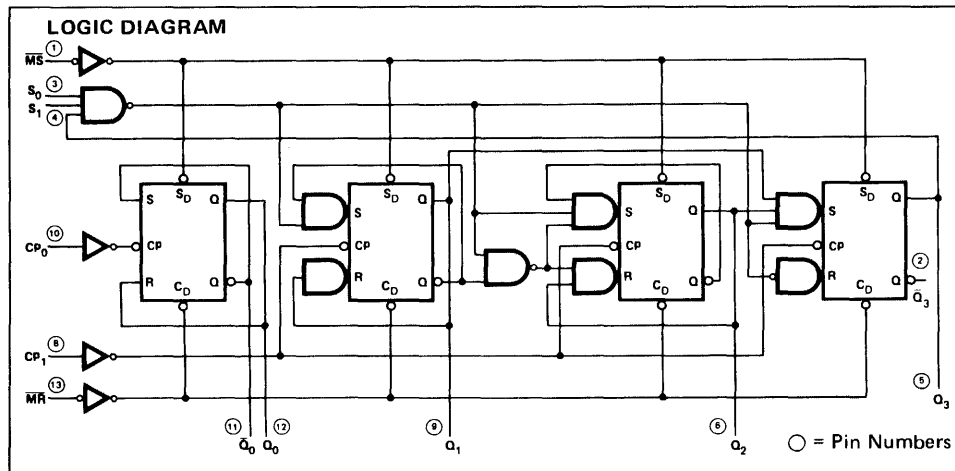

LOGIC SYMBOL

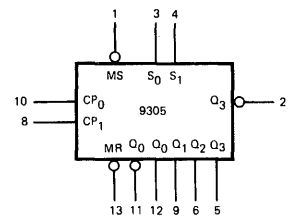

V_{CC} = Pin 14
 GND = Pin 7

CONNECTION DIAGRAMS
DIP (TOP VIEW)

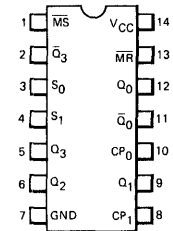

FLATPAK (TOP VIEW)

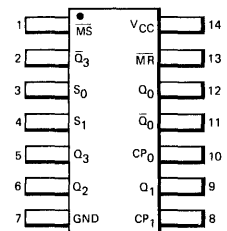

*Planar is a patented Fairchild process.

FUNCTIONAL DESCRIPTION — The MSI 9305 consists of four master-slave flip-flops which are separated into two functional units — a single toggle stage and a three stage synchronous counter. All four flip-flops change state on the LOW to HIGH transition of the clock. The three stage counter can be programmed with external connections as shown in the table below to provide modulo of either 5, 6, 7 or 8. This basic configuration allows synchronous binary counting by the last three stages and independent modulo 2 operation with the first single stage.

A four stage binary counter with a modulo of 10, 12, 14 or 16 is obtained by applying the incoming clock to the single toggle stage and feeding its negation output to the clock input of the three stage counter. A 4-stage divider with 50% duty cycle output is produced by feeding the incoming clock to the three stage counter and clocking the single stage with the \bar{Q}_3 output. In either the binary or 50% division mode the modulo (10, 12, 14, 16) is determined by the external programming connections for the three stage counter. These 4-stage counters or dividers are not fully synchronous (semisynchronous) but have only one flip-flop ripple delay in either configuration. Counter modulus other than 10, 12, 14, 16 can be formed with a few extra gates.

Several 9305 variable modulo counters programmed in any modulo can be connected together without extra logic to form asynchronous (ripple) type multistage counters. This is done by connecting the \bar{Q}_3 output of the less significant counter to the clock input of the following counter.

The Master Set and Reset will asynchronously set or reset all four stages when activated. The active LOW Reset input when LOW will clear the counter, overriding the clock and forcing the outputs (Q_{0-3}) LOW and outputs \bar{Q}_0, \bar{Q}_3 HIGH. The active LOW Set input when LOW will preset the counter, overriding the clock and forcing the outputs Q_{0-3} HIGH and outputs \bar{Q}_0, \bar{Q}_3 LOW. The master set provides a synchronous clear, since the first clock pulse following the asynchronous master set will reset all stages. This action is independent of the modulo programmed.

COUNTING MODE

The following are rules specifying the external connections required for various counter and divider modulus.

ASYNCHRONOUS MODE

\overline{MS}	\overline{MR}	Q_0	\bar{Q}_0	Q_1	Q_2	Q_3	\bar{Q}_3
L	H	H	L	H	H	H	L
H	L	L	H	L	L	L	H
H	H	COUNT*					

*As determined by programming connections.

PROGRAMMING CONNECTIONS FOR LAST THREE STAGES

S_0	S_1	MODULO
NC	NC	5
Q_1	NC	6
NC	Q_1	6
Q_2	NC	7
NC	Q_2	7
Q_1	Q_2	8
Q_2	Q_1	8

NC = Not Connected

ALTERNATE PROGRAMMING CONNECTIONS FOR LAST THREE STAGES**

S_0	S_1	MODULO
Q_3	Q_3	5
Q_1	Q_1	6
Q_2	Q_2	7
Q_1	Q_2	8
Q_2	Q_1	8

**The alternate programming connections program the counter and conveniently terminate unused select inputs (NC). Since these inputs form the inputs to a single NAND gate (see logic diagram), their connection to the counter outputs for the various count modulus provides the following output drive:

CONNECTIONS FOR MODULO 10, 12, 14, 16 BINARY COUNTERS AND 50% DUTY CYCLE DIVIDERS

For Binary Counting \bar{Q}_0 connected to CP_1 Incoming clock to CP_0
For 50% Duty Cycle Output \bar{Q}_3 connected to CP_0 Incoming Clock to CP_1

MODULO	OUTPUT	AVAILABLE OUTPUT FANOUT
5	Q_3	14/8
6	Q_1	14/7
7	Q_2	14/7
8	Q_1	15/7
8	Q_2	15/7

FAIRCHILD TTL/MSI • 9305

ABSOLUTE MAXIMUM RATINGS (above which the useful life may be impaired)

Storage Temperature	-65°C to +150°C
Temperature (Ambient) Under Bias	-55°C to +125°C
V _{CC} Pin Potential to Ground Pin	-0.5 V to +7.0 V
*Input Voltage (dc)	-0.5 V to +5.5 V
*Input Current (dc)	-30 mA to +5.0 mA
Voltage Applied to Outputs (Output HIGH)	-0.5 V to +V _{CC} value
Output Current (dc) (Output LOW)	+30 mA

*Either Input Voltage Limit or Input Current is sufficient to protect the inputs.

GUARANTEED OPERATING RANGES

PART NUMBER	SUPPLY VOLTAGE (V _{CC})			TEMPERATURE
	MIN.	TYP.	MAX.	
9305XM	4.5 V	5.0 V	5.5 V	-55°C to 125°C
9305XC	4.75 V	5.0 V	5.25 V	0°C to 75°C

X = package type; F for Flatpak, D for Ceramic Dip, P for Plastic Dip. See Packaging Information Section for packages available on this product.

ELECTRICAL CHARACTERISTICS OVER OPERATING TEMPERATURE RANGE (unless otherwise noted)

SYMBOL	PARAMETER	LIMITS			UNITS	CONDITIONS
		MIN.	TYP. (Note 4)	MAX.		
V _{IH}	Input HIGH Voltage	2.0			Volts	Guaranteed Input HIGH Threshold Voltage for All Inputs
V _{IL}	Input LOW Voltage			0.8	Volts	Guaranteed Input LOW Threshold Voltage for All Inputs
V _{CD}	Input Clamp Diode Voltage			-1.5	Volts	V _{CC} = MIN., I _{IN} = -12mA, T _A = 25°C
V _{OH}	Output HIGH Voltage	2.4	3.6		Volts	I _{OH} = -800 μA (Pin 2) V _{CC} = MIN., I _{OH} = -640 μA V _{IN} = V _{IH} or V _{IL} per Mode Table
V _{OL}	Output LOW Voltage		0.2	0.4	Volts	I _{OL} = 16 mA (Pin 2) V _{CC} = MIN., I _{OL} = 12.8 mA V _{IN} = V _{IH} or V _{IL} per Mode Table
I _{IH}	Input HIGH Current		10	40	μA	V _{CC} = MAX., V _{IN} = 2.4 V
				1.0	mA	V _{CC} = MAX., V _{IN} = 5.0 V
I _{IL}	Input LOW Current		-0.96	-1.6	mA	V _{CC} = MAX., V _{IN} = 0.4 V
I _{SC} (I _{OS})	Output Short Circuit Current (Note 5)	-30	-65	-100	mA	V _{CC} = MAX., V _{OUT} = 0.0 V
I _{CC}	Power Supply Current		42	66	mA	V _{CC} = MAX.

NOTES:

- (1) The actual testing procedures used to guarantee the Electrical Characteristics are contained in a detailed Customer Sample Specification. A copy of this specification can be obtained from Fairchild Digital Product Marketing, Mountain View, California.
- (2) Conditions for testing, not shown in the Table, are chosen to guarantee operation under "worst case" conditions.
- (3) The specified LIMITS represent the "worst case" value for the parameter. Since these "worst case" values normally occur at the temperature and supply voltage extremes, additional noise immunity and guard banding can be achieved by decreasing the allowable system operating ranges.
- (4) Typical limits are at V_{CC} = 5.0 V, 25°C, and maximum loading.
- (5) Not more than one output should be shorted at a time.

SWITCHING CHARACTERISTICS (T_A = 25°C)

SYMBOL	PARAMETER	9305XM			9305XC			UNITS	TEST CONDITIONS
		MIN.	TYP.	MAX.	MIN.	TYP.	MAX.		
f _{COUNT}	Input Count Frequency	20	26		20	26		MHz	V _{CC} = 5.0 V, C _L = 15 pF Modulo 16 (S ₀ to Q ₁ , S ₁ to Q ₂ , Q ₀ to CP ₁) Input CP ₀
t _{PLH}	Turn-Off Delay Input to Output (CP ₀ to Q ₃ , Modulo 16 Connection)		48	57		48	62	ns	
t _{PHL}	Turn-On Delay Input to Output (CP ₀ to Q ₃ , Modulo 16 Connection)		44	53		44	58	ns	

TYPICAL INPUT AND OUTPUT CHARACTERISTICS

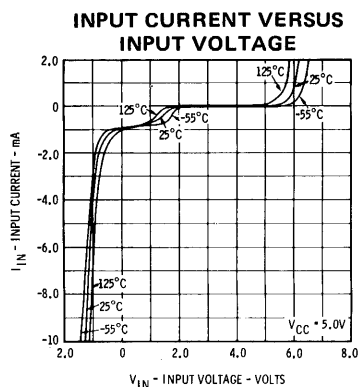

INPUT EQUIVALENT CIRCUIT

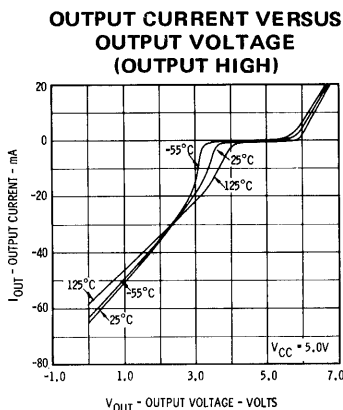
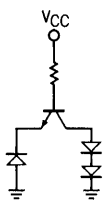

OUTPUT EQUIVALENT CIRCUIT (Output HIGH)

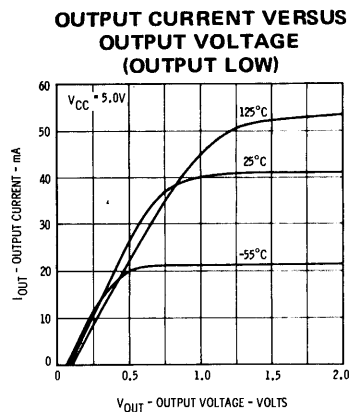
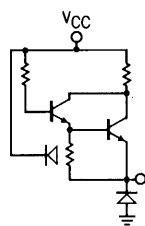

OUTPUT EQUIVALENT CIRCUIT (Output LOW)

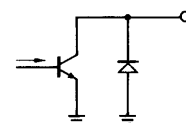

SWITCHING CHARACTERISTICS

TYPICAL PROPAGATION DELAY VERSUS TEMPERATURE CP₀ TO Q₀ MODULO 16

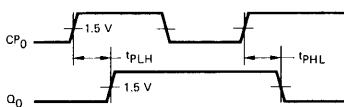
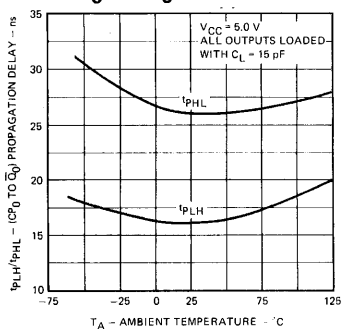

PIN 3 TO PIN 9, PIN 4 TO PIN 6
PIN 8 TO PIN 11, OTHERS OPEN

TYPICAL PROPAGATION DELAY VERSUS TEMPERATURE CP₀ TO Q₀ MODULO 16

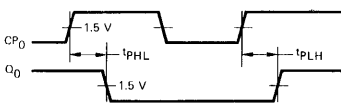
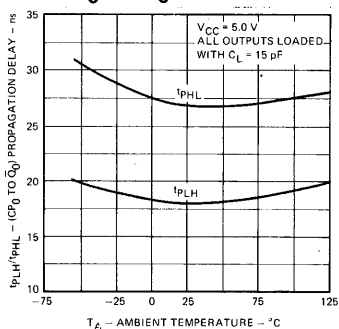

PIN 3 TO PIN 9, PIN 4 TO PIN 6
PIN 8 TO PIN 11, OTHERS OPEN

TYPICAL PROPAGATION DELAY VERSUS TEMPERATURE CP₁ TO Q₃ MODULO 8

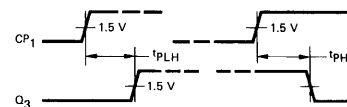
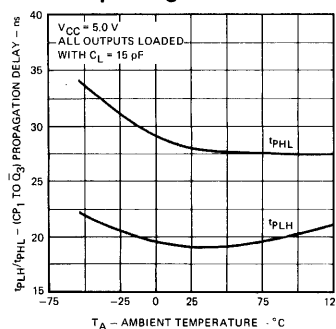

PIN 3 TO PIN 9, PIN 4 TO PIN 6
OTHERS OPEN

SWITCHING CHARACTERISTICS (Continued)

TYPICAL PROPAGATION DELAY VERSUS TEMPERATURE
CP₁ TO Q₃ MODULO

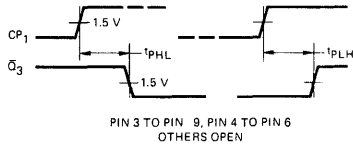
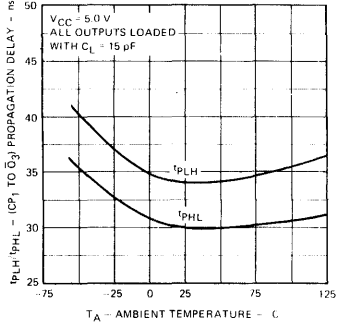

TYPICAL PROPAGATION DELAY VERSUS TEMPERATURE
t_{PLH} MS TO Q₁ t_{PHL} MR TO Q₁
MODULO 8

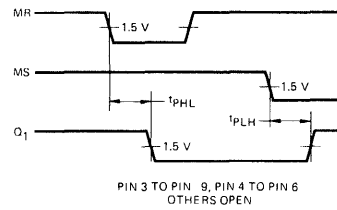
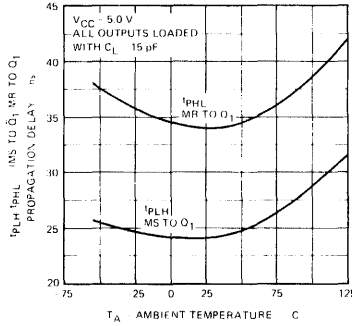

TYPICAL MINIMUM PULSE WIDTH TO TOGGLE VERSUS TEMPERATURE
CP₀ MODULO 16

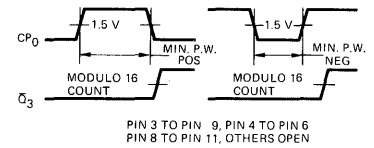
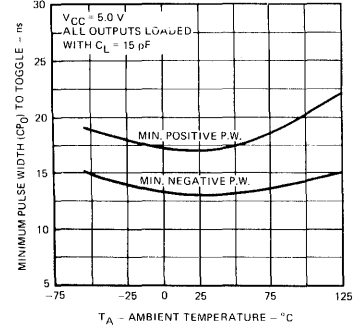

TYPICAL MINIMUM PULSE WIDTH TO RESET, SET VERSUS TEMPERATURE
MR, MS MODULO 16

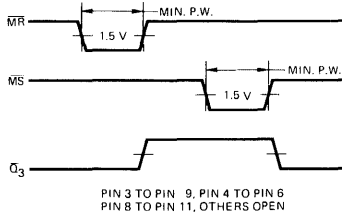
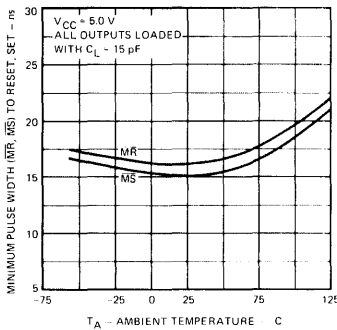

TYPICAL RECOVERY TIME VERSUS TEMPERATURE
MS TO CP₁, MR TO CP₁ MODULO 8

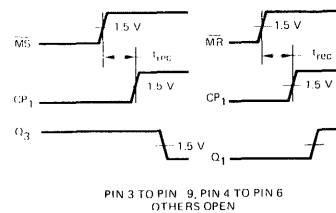
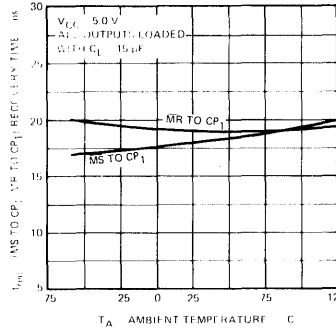

TYPICAL SET-UP TIME VERSUS TEMPERATURE
S₀ TO CP₁ MODULO 6

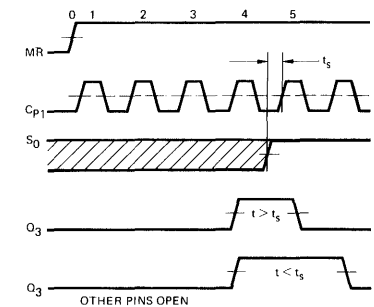
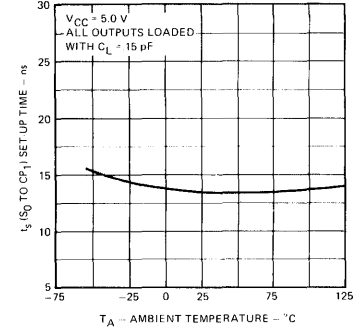

t_s is the time required that S_0 must go HIGH before CP_1 clock goes HIGH, such that the circuit recognizes the S_0 as being HIGH. The graph above indicates that times greater than t_s will result in Modulo 5 operation; and that values less than t_s will result in Modulo 6 operation. The shaded area indicates when the input is permitted to change for predictable output performance.

t_{rec} is the time that the MR (or MS) must go HIGH before the clock (CP_1) goes HIGH such that the circuit recognizes the clock (CP_1) pulse.

TTL/MSI 93S05

VARIABLE MODULO COUNTER

DESCRIPTION — The TTL/MSI 93S05 is a monolithic, high speed, Variable Modulo Counter circuit, constructed with the TTL Schottky Barrier Diode process. It is a semisynchronous counter which can be programmed without extra logic to provide division or counting by either 2 and 4, 5, 6, 7, 8, or 10, 12, 14, 16. A binary count sequence can be obtained for all of the preceding counter modulus as well as 50% duty cycle output for dividers of 8, 10, 12, 14, 16. The device also features asynchronous overriding master reset and set inputs and the negation output of the final flip-flop output which allows the cascading of stages. The circuit uses Schottky TTL for super high speed, high fanout operation and is compatible with all other members of the TTL family of digital integrated circuits.

- **VARIOUS BINARY COUNTING MODES**
 - MODULO 2 AND MODULO 5, 6, 7, 8
 - MODULO 10 (8421 BCD), 12, 14, 16
- **VARIOUS FREQUENCY DIVISION MODES WITH 50% DUTY CYCLE OUTPUT**
 - MODULO 8, 10, 12, 14, 16
- **LOGIC SELECTION OF COUNTING MODE**
- **ASYNCHRONOUS MASTER RESET AND SET INPUTS**
- **MULTISTAGE COUNTING OPERATION**
- **TYPICAL COUNTING FREQUENCY OF 100 MHz**
- **INPUT CLAMP DIODES LIMIT HIGH SPEED TERMINATION EFFECTS**

PIN NAMES

S_0, S_1	Select Inputs
CP_0	First Stage Clock Active HIGH Going Edge Input
CP_1	Three Stage Clock Active HIGH Going Edge Input
\overline{MS}	Master Set (Active LOW) Input
\overline{MR}	Master Reset (Active LOW) Input
Q_0	First Stage Output
\overline{Q}_0	Complementary First Stage Output
Q_1, Q_2, Q_3	Three Stage Counter Outputs
\overline{Q}_3	Complementary Last Stage Output

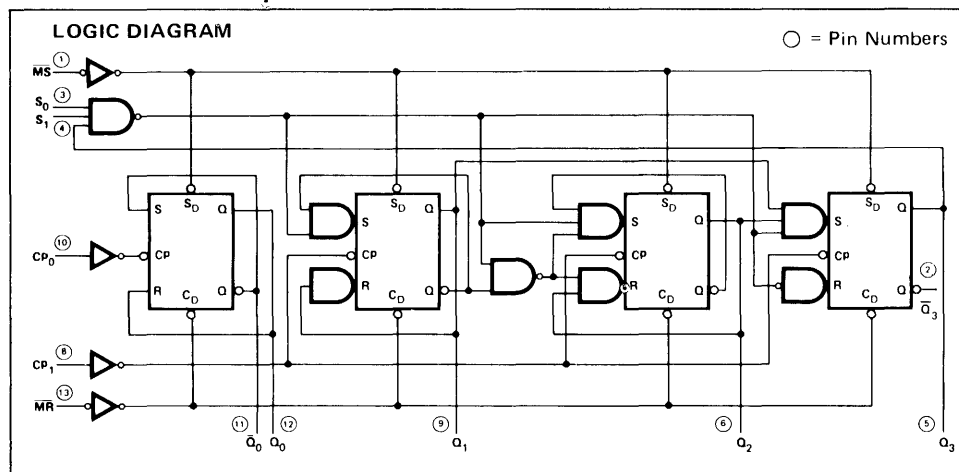

LOGIC SYMBOL

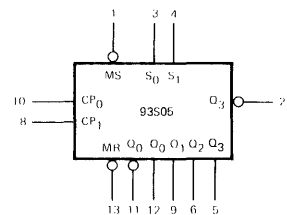

V_{CC} = Pin 14

GND = Pin 7

CONNECTION DIAGRAMS DIP (TOP VIEW)

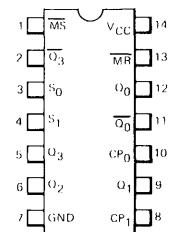

FLATPAK (TOP VIEW)

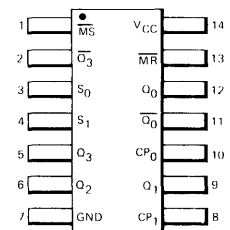

TTL/MSI 9307

SEVEN SEGMENT DECODER

DESCRIPTION — The 9307 is a Seven Segment Decoder designed to accept four inputs in 8421 BCD code and provide the appropriate outputs to drive a seven segment numerical display. The decoder can be used with seven segment incandescent lamp, neon, electro-luminescent, or CRT numeric displays. The 9307 is compatible with all other Fairchild TTL devices.

- TTL COMPATIBLE
- AUTOMATIC RIPPLE BLANKING FOR SUPPRESSION OF LEADING EDGE ZEROES
- LAMP INTENSITY MODULATION CAPABILITY
- LAMP TEST FACILITY
- BLANKING INPUT
- ACTIVE HIGH OUTPUTS
- ALL CERAMIC "HERMETIC" 16-LEAD DUAL IN-LINE PACKAGE

ABSOLUTE MAXIMUM RATINGS (above which the useful life may be impaired)

Storage Temperature	-65°C to +150°C
Temperature (Ambient) Under Bias	-55°C to +125°C
V _{CC} Pin Potential to Ground Pin	-0.5 V to +7 V
Voltage Applied to Outputs for HIGH Output State	-0.5 V to +V _{CC} value
Input Voltage (dc)	-0.5 V to +5.5 V

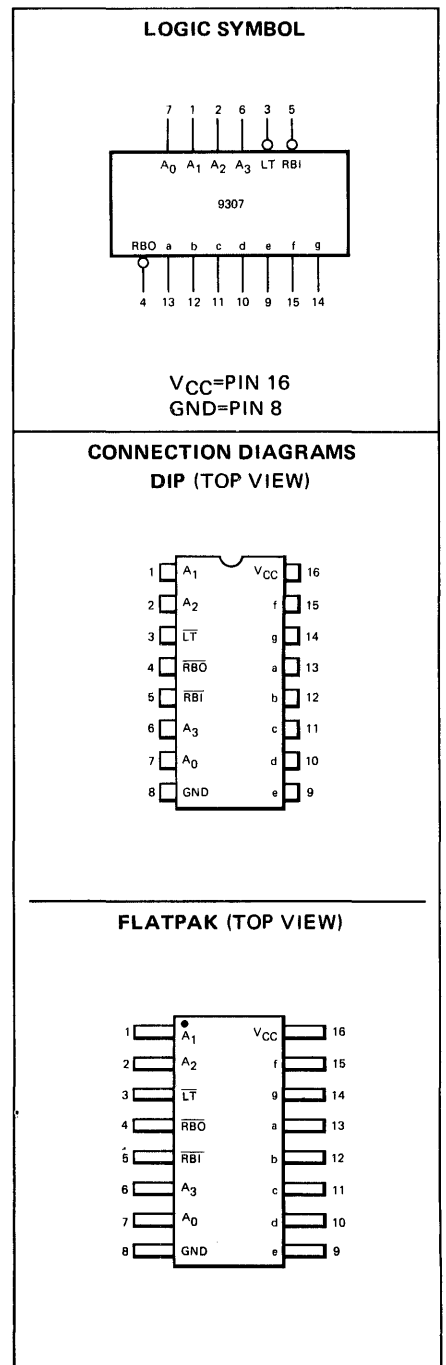
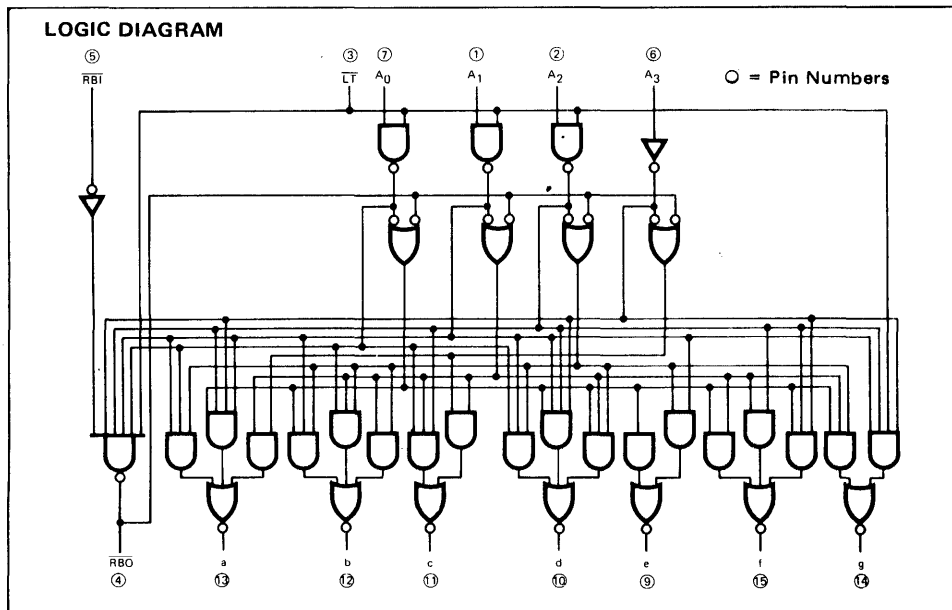

The 9307 seven segment decoder accepts a 4-bit BCD 8421 code input and produces the appropriate outputs for selection of segments in a seven segment matrix display used for representing the decimal numbers 0-9. The seven outputs (a, b, c, d, e, f, g) of the decoder select the corresponding segments in the matrix shown in Figure 1. The numeric designations chosen to represent the decimal numbers are shown in Figure 3, together with the resulting displays for input code configurations in excess of binary nine.

The decoder has active HIGH outputs so that a buffer transistor may be used directly to provide the high currents required for incandescent displays. If additional base drive current is required external resistors may be added from the supply voltage to the seven segment outputs of the decoders. The value of this resistor is constrained by the 10 mA current sinking capability of the output transistors of the circuit.

The device has provision for automatic blanking of the leading and/or trailing edge zeroes in a multidigit decimal number, resulting in an easily readable decimal display conforming to normal writing practice. In an eight digit mixed integer fraction decimal representation, using the automatic blanking capability, 0060.0300 would be displayed as 60.03. Leading edge zero suppression is obtained by connecting the Ripple Blanking Output (RBO) of a decoder to the Ripple Blanking Input (RBI) of the next lower stage device. The most significant decoder stage should have the RBI input grounded; and, since suppression of the least significant integer zero in a number is not usually desired, the RBI input of this decoder stage should be left open. A similar procedure for the fractional part of a display will provide automatic suppression of trailing edge zeroes.

The decoder has an active LOW input Lamp Test which overrides all other input combinations and enables a check to be made on possible display malfunctions. The RBO terminal of the decoder can be OR-tied with a modulating signal via an isolating buffer to achieve pulse duration intensity modulation. A suitable signal can be generated for this purpose by forming a variable frequency multivibrator with a cross coupled pair of DTL gates.

SEGMENT DESIGNATION

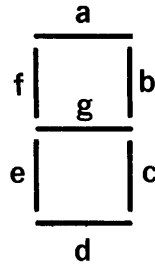

Fig. 1

TRUTH TABLE

$\overline{\text{LT}}$	$\overline{\text{RB}}$	IN	A_0	A_1	A_2	A_3	a	b	c	d	e	f	g	$\overline{\text{RB}}$	OUT
L	X	X	X	X	X	X	H	H	H	H	H	H	H	H	0
H	L	L	L	L	L	L	L	L	L	L	L	L	L	L	1
H	H	L	L	L	L	L	H	H	H	H	H	L	H	H	2
H	X	H	L	L	L	L	L	H	L	L	L	L	L	H	3
H	L	L	L	L	L	L	H	H	L	H	H	L	H	H	4
H	L	L	L	L	L	L	H	H	L	L	L	L	H	H	5
H	L	L	L	L	L	L	H	L	H	L	L	L	H	H	6
H	L	L	L	L	L	L	H	H	H	L	L	L	L	H	7
H	L	L	L	L	L	L	H	L	L	L	H	L	L	H	8
H	L	L	L	L	L	L	H	H	H	H	H	H	H	H	9
H	L	L	L	L	L	L	H	L	L	L	L	L	L	H	10
H	L	L	L	L	L	L	H	L	L	L	L	L	L	H	11
H	L	L	L	L	L	L	H	L	L	L	L	L	L	H	12
H	L	L	L	L	L	L	H	L	L	L	L	L	L	H	13
H	L	L	L	L	L	L	H	L	L	L	L	L	L	H	14
H	X	H	H	H	H	H	L	L	L	L	L	L	L	H	15

H = HIGH Voltage Level
L = LOW Voltage Level
X = Either HIGH or LOW Voltage Level

Fig. 2

NUMERICAL DESIGNATIONS

0	1	2	3	4	5	6	7	8	9	10	11	12	13	14	15

Fig. 3

Table 1 - LOADING RULES (1 U.L. = 1 DTL GATE INPUT LOAD)

Inputs	Loading (MIL & IND)	
	HIGH State	LOW State
A_0, A_1, A_2, A_3	1	1
$\overline{\text{RB}}(\text{IN})$	1	1/2
$\overline{\text{LT}}$	5	4.3

Outputs	Fan Out	
	MIL	IND
a, b, c, d, e, f, g	8	7
$\overline{\text{RB}}(\text{OUT})$	2.0	1.5

FAIRCHILD TTL/MSI • 9307

TABLE II – ELECTRICAL CHARACTERISTICS ($T_A = -55^\circ\text{C}$ to $+125^\circ\text{C}$, $V_{CC} = 5.0\text{ V} \pm 10\%$) (Part No. 9307XM, see note)

SYMBOL	PARAMETER	LIMITS						UNITS	CONDITIONS
		-55°C		$+25^\circ\text{C}$			$+125^\circ\text{C}$		
		MIN.	MAX.	MIN.	TYP.	MAX.	MIN.	MAX.	
V_{OH}	Output HIGH Voltage	4.3	3.0	4.3	4.4	4.0	4.3	3.0	$V_{CC} = 4.5\text{ V}$ $I_{OH} = 0.0\text{ mA}$ (Pins 9-15) $V_{CC} = 4.5\text{ V}$ $I_{OH} = -70\text{ }\mu\text{A}$ (Pin 4) Inputs at Threshold Voltages (V_{IL} or V_{IH})
V_{OL}	Output LOW Voltage		0.4		0.21	0.4		0.4	$V_{CC} = 5.5\text{ V}$ $I_{OL} = 12.5\text{ mA}$ (Pins 9-15) $I_{OL} = 3.1\text{ mA}$ (Pin 4) $V_{CC} = 4.5\text{ V}$ $I_{OL} = 10\text{ mA}$ (Pins 9-15) $I_{OL} = 2.4\text{ mA}$ (Pin 4) Inputs at Threshold Voltages (V_{IL} or V_{IH})
V_{IH}	Input HIGH Voltage	2.1		1.9			1.7		Guaranteed Input HIGH Threshold Voltage for All Inputs
V_{IL}	Input LOW Voltage		1.4			1.1		0.8	Guaranteed Input LOW Threshold Voltage for All Inputs
(Pin 3) I_{IL} (Pins 1, 2, 6, 7) (Pin 5)	Input LOW Current		-6.4			-6.4		-6.4	$V_{CC} = 5.5\text{ V}$ $V_{IN} = 0.4\text{ V}$ Other Inputs = 5.5 V
(Pin 3) I_{IH} (Pins 1, 2, 5, 6, 7)	Input HIGH Current					10		25	$V_{CC} = 5.5\text{ V}$ $V_{IN} = 4.5\text{ V}$ Ground on Other Inputs
I_A (Pins 9-15)	Available Output Current	-1.4		-1.4				2.0	$V_{OUT} = 0.85\text{ V}$ $V_{CC} = 4.5\text{ V}$ Inputs at Threshold Voltages (V_{IL} or V_{IH})
I_{SC} (Pins 9-15)	Short Circuit Current							-3.7	$V_{OUT} = 0.0\text{ V}$ $V_{CC} = 5.5\text{ V}$
I_{CC}	Supply Current		73					73	$V_{CC} = 5.5\text{ V}$
t_{PLH}	Turn Off Delay					500			$V_{CC} = 5.0\text{ V}$, See Fig. 5
t_{PHL}	Turn On Delay					500			

TABLE III -- ELECTRICAL CHARACTERISTICS ($T_A = 0^\circ\text{C}$ to $+75^\circ\text{C}$, $V_{CC} = 5.0\text{ V} \pm 5\%$) (Part No. 9307XC, see note)

SYMBOL	PARAMETER	LIMITS						UNITS	CONDITIONS
		0°C		$+25^\circ\text{C}$			$+75^\circ\text{C}$		
		MIN.	MAX.	MIN.	TYP.	MAX.	MIN.	MAX.	
V_{OH}	Output HIGH Voltage	4.3	2.7	4.3	4.6	4.0	4.3	2.7	$V_{CC} = 4.75\text{ V}$ $I_{OH} = 0.0\text{ mA}$ (Pins 9-15) $V_{CC} = 4.75\text{ V}$ $I_{OH} = -70\text{ }\mu\text{A}$ (Pin 4) Inputs at Threshold Voltages (V_{IL} or V_{IH})
V_{OL}	Output LOW Voltage		0.45		0.21	0.45		0.45	$V_{CC} = 5.25\text{ V}$ $I_{OL} = 11.5\text{ mA}$ (Pins 9-15) $I_{OL} = 2.75\text{ mA}$ (Pin 4) $V_{CC} = 4.75\text{ V}$ $I_{OL} = 10\text{ mA}$ (Pins 9-15) $I_{OL} = 2.4\text{ mA}$ (Pin 4) Inputs at Threshold Voltages (V_{IL} or V_{IH})
V_{IH}	Input HIGH Voltage	2.0		2.0			2.0		Guaranteed Input HIGH Threshold Voltage for All Inputs
V_{IL}	Input LOW Voltage		0.85			0.85		0.85	Guaranteed Input LOW Threshold Voltage for All Inputs
(Pin 3) I_{IL} (Pins 1, 2, 6, 7) (Pin 5)	Input LOW Current		-6.4			-6.4		-6.4	$V_{CC} = 5.25\text{ V}$ $V_{IN} = 0.45\text{ V}$ Other Inputs = 5.25 V
(Pin 3) I_{IH} (Pins 1, 2, 5, 6, 7)	Input HIGH Current					25		50	$V_{CC} = 5.25\text{ V}$ $V_{IN} = 4.5\text{ V}$ Ground on Other Inputs
I_A (Pins 9-15)	Available Output Current	-1.4		-1.4				10	$V_{OUT} = 0.75\text{ V}$ $V_{CC} = 4.75\text{ V}$ Inputs at Threshold Voltages (V_{IL} or V_{IH})
I_{SC} (Pins 9-15)	Short Circuit Current							-4.0	$V_{OUT} = 0.0\text{ V}$ $V_{CC} = 5.25\text{ V}$
I_{CC}	Supply Current		82					82	$V_{CC} = 5.25\text{ V}$
t_{PLH}	Turn Off Delay					500			$V_{CC} = 5.0\text{ V}$, See Fig. 5
t_{PHL}	Turn On Delay					500			

Note:

X = package type; F for Flatpak, D for Ceramic Dip, P for Plastic Dip. See Packaging Information Section for packages available on this product.

INPUTS

EQUIVALENT CIRCUIT

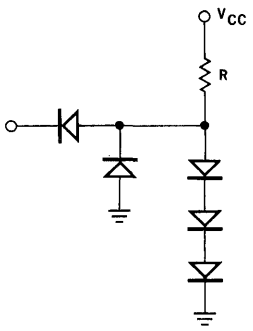

TYPICAL INPUT AND OUTPUT CHARACTERISTICS
INPUT CURRENT VERSUS INPUT VOLTAGE

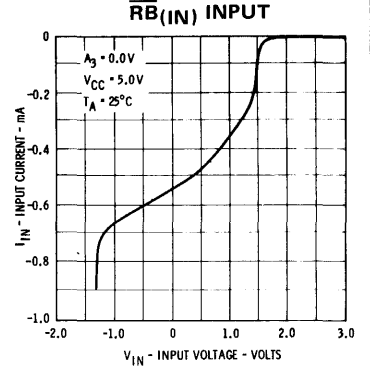
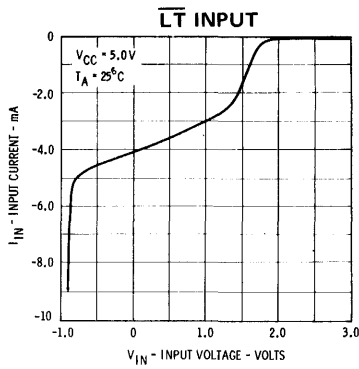
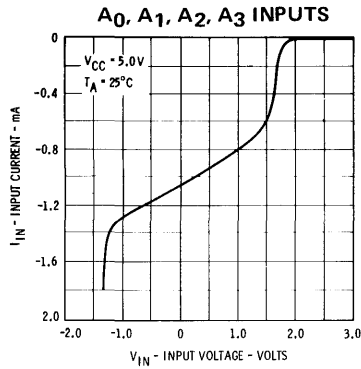

OUTPUT CURRENT VERSUS OUTPUT VOLTAGE

9307XM (-55°C to +125°C)
OUTPUT IN HIGH STATE

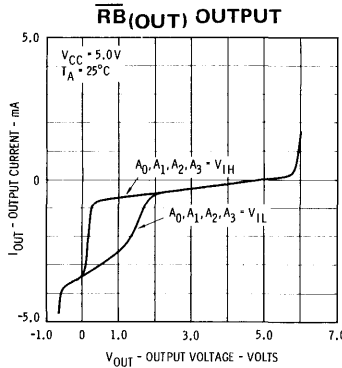
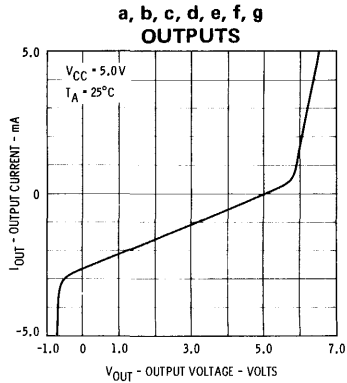

9307XC (0°C to +75°C)
OUTPUT IN HIGH STATE

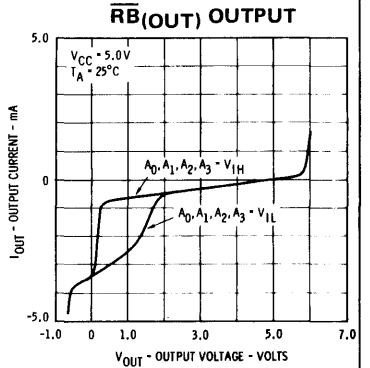
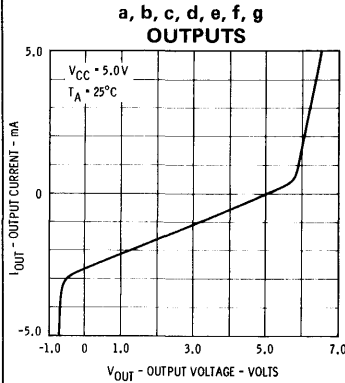

OUTPUT IN LOW STATE

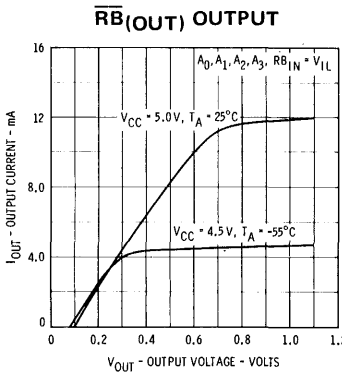
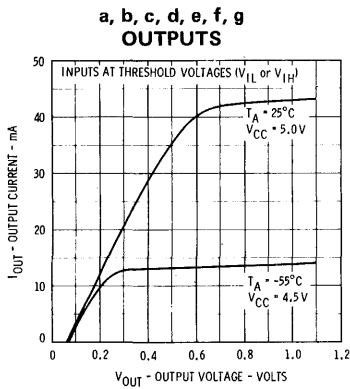

OUTPUT IN LOW STATE

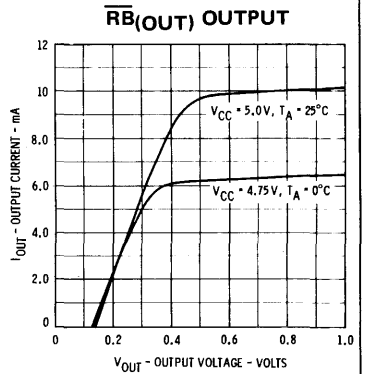
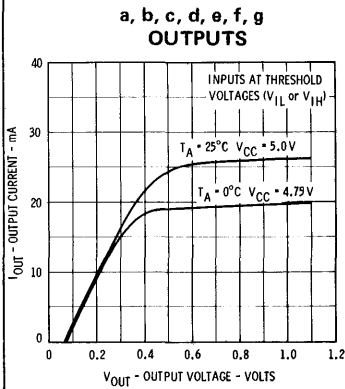

OUTPUT

EQUIVALENT CIRCUIT

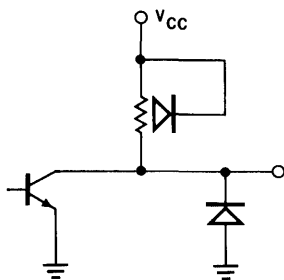

Fig. 4

SWITCHING WAVEFORMS

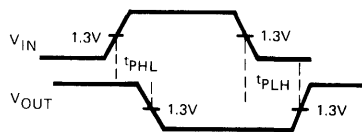

Fig. 5

TTL/MSI 9308

DUAL FOUR-BIT LATCH

DESCRIPTION — The MSI 9308 is a dual 4-Bit Latch designed for general purpose storage applications in high speed digital systems. The 9308 uses TTL technology and is compatible with DTL, TTL, and MSI families. All inputs incorporate diode clamps to ground to reduce negative line transients. All outputs have active pull-up circuitry to provide high capacitive drive and low impedance outputs in both logic states to provide good ac noise immunity.

- ACTIVE LEVEL LOW ENABLE GATE INPUTS
- OVERRIDING MASTER RESET
- 25 ns THROUGH DELAY
- THE INPUT/OUTPUT CHARACTERISTICS PROVIDE DIRECT INTERFACING WITH FAIRCHILD DTL, LPDTL, TTL, AND MSI FAMILIES
- INPUT CLAMP DIODES LIMIT HIGH SPEED TERMINATION EFFECTS
- HIGH CAPACITIVE DRIVE CAPABILITY
- ALL CERAMIC HERMETIC 24-LEAD DUAL IN-LINE PACKAGE

PIN NAMES

D_0, D_1, D_2, D_3	Parallel Latch Inputs
$\overline{E}_0, \overline{E}_1$	AND Enable (Active LOW) Inputs
\overline{MR}	Master Reset (Active LOW) Input
Q_0, Q_1, Q_2, Q_3	Parallel Latch Outputs (Note b)

NOTES:

- 1 unit load (U.L.) = 40 μ A HIGH/1.6 mA LOW.
- 9 U.L. is the output LOW drive factor and 18 U.L. is the output HIGH drive factor.

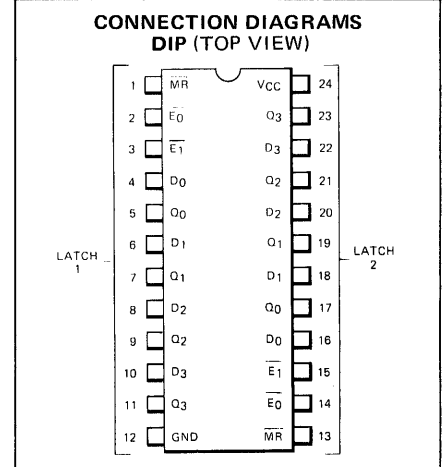
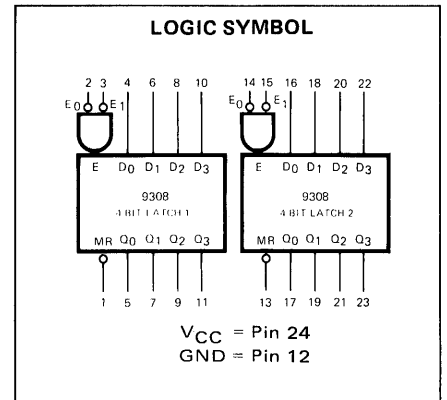

LOADING

(Note a)
1.5 U.L.
1 U.L.
1 U.L.
9 U.L.

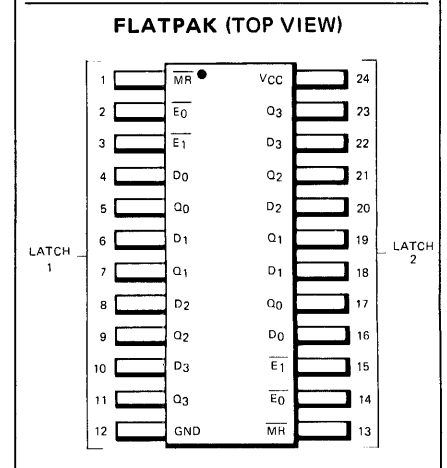
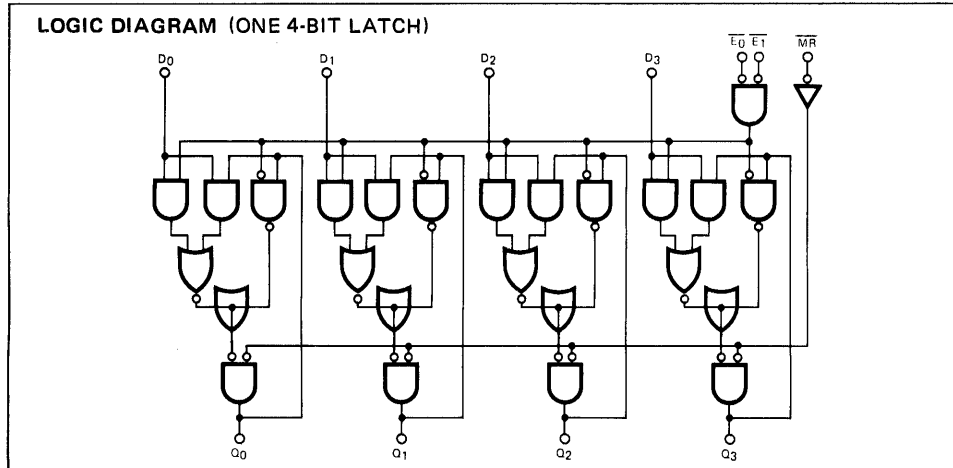

FAIRCHILD TTL/MSI • 9308

FUNCTIONAL DESCRIPTION

LATCH OPERATION — Data can be entered into the latch when both of the enable inputs are LOW. As long as this logic condition exists, the output of the latch will follow the input. If either of the enable inputs goes HIGH, the data present in the latch at that time is held in the latch and is no longer affected by data input.

The master reset overrides all other input conditions and forces the outputs of all the latches LOW when a LOW signal is applied to the master reset input.

TRUTH TABLE

\overline{MR}	$\overline{E_0}$	$\overline{E_1}$	D	Q_n	OPERATION
H	L	L	L	L	Data Entry
H	L	L	H	H	Data Entry
H	L	H	X	Q_{n-1}	Hold
H	H	L	X	Q_{n-1}	Hold
H	H	H	X	Q_{n-1}	Hold
L	X	X	X	L	Reset

X = Don't Care
 L = LOW Voltage Level
 H = HIGH Voltage Level
 Q_{n-1} = Previous Output State
 Q_n = Present Output State

TYPICAL INPUT AND OUTPUT CHARACTERISTICS

INPUTS

EQUIVALENT CIRCUIT

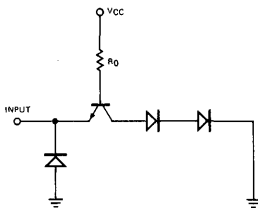

INPUT CURRENT VERSUS INPUT VOLTAGE

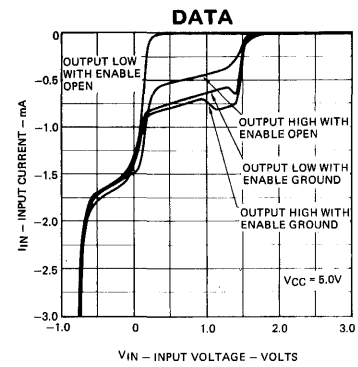
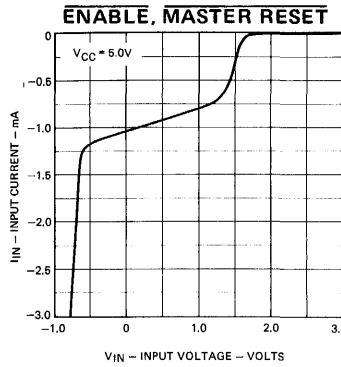

OUTPUTS

EQUIVALENT CIRCUIT

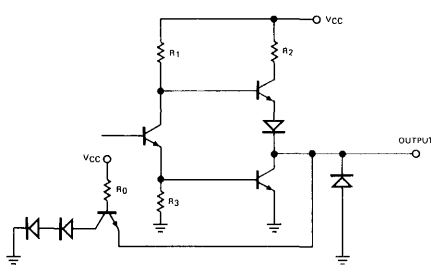

OUTPUT CURRENT VERSUS OUTPUT VOLTAGE

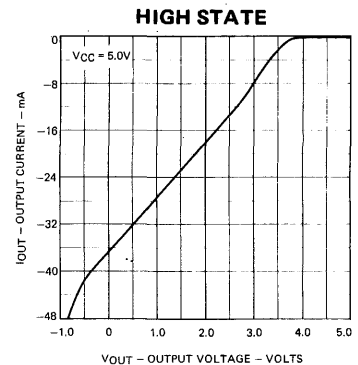
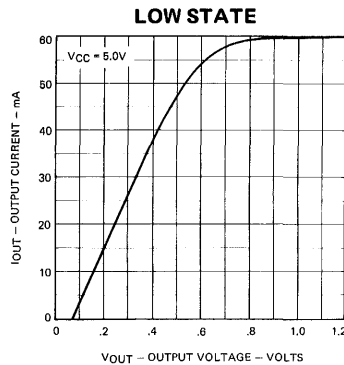

FAIRCHILD TTL/MSI • 9308

ABSOLUTE MAXIMUM RATINGS (above which the useful life may be impaired)

Storage Temperature	-65°C to +150°C
Temperature (Ambient) Under Bias	-55°C to +125°C
V _{CC} Pin Potential to Ground Pin	-0.5 V to +7.0 V
*Input Voltage (dc)	-0.5 V to +5.5 V
*Input Current (dc)	-30 mA to +5.0 mA
Voltage Applied to Outputs (Output HIGH)	-0.5 V to +V _{CC} value
Output Current (dc) (Output LOW)	+30 mA

*Either Input Voltage Limit or Input Current Is sufficient to protect the inputs.

GUARANTEED OPERATING RANGES

PART NUMBER	SUPPLY VOLTAGE (V _{CC})			TEMPERATURE
	MIN.	TYP.	MAX.	
9308XM	4.5 V	5.0 V	5.5 V	-55°C to 125°C
9308XC	4.75 V	5.0 V	5.25 V	0°C to 75°C

X = package type; F for Flatpak, D for Ceramic Dip, P for Plastic Dip. See Packaging Information Section for packages available on this product.

ELECTRICAL CHARACTERISTICS OVER OPERATING TEMPERATURE RANGE (unless otherwise noted)

SYMBOL	PARAMETER	LIMITS			UNITS	CONDITIONS
		MIN.	TYP. (Note 4)	MAX.		
V _{IH}	Input HIGH Voltage	2.0			Volts	Guaranteed Input HIGH Threshold Voltage for all Inputs
V _{IL}	Input LOW Voltage			0.8	Volts	Guaranteed Input LOW Threshold Voltage for all Inputs
V _{CD}	Input Clamp Diode Voltage			-1.5	Volts	V _{CC} = MIN., I _{IN} = -12 mA, T _A = 25°C
V _{OH}	Output HIGH Voltage	2.4	3.6		Volts	V _{CC} = MIN., I _{OH} = -720 μA V _{IN} = V _{IH} or V _{IL} per Truth Table
V _{OL}	Output LOW Voltage		0.2	0.4	Volts	V _{CC} = MIN., I _{OL} = 14.4 mA V _{IN} = V _{IH} or V _{IL} per Truth Table
I _{IH}	Input HIGH Current					V _{CC} = MAX., V _{IN} = 2.4V
	$\overline{E_0}, \overline{E_1}$ & \overline{MR}		10	40	μA	
	D ₀ , D ₁ , D ₂ & D ₃		15	60	μA	
	Input HIGH Current All Inputs			1.0	mA	V _{CC} = MAX., V _{IN} = 5.0 V
I _{IL}	Input LOW Current					V _{CC} = MAX., V _{IN} = 0.4V
	$\overline{E_0}, \overline{E_1}$ & \overline{MR}		-0.96	-1.6	mA	
	D ₀ , D ₁ , D ₂ & D ₃		-1.44	-2.4*	mA	* Max Instantaneous Current Out of The D Inputs
I _{SC} (I _{OS})	Output Short Circuit Current (Note 5)	-20	-40	-70	mA	V _{CC} = MAX., V _{OUT} = 0.0 V
I _{CC}	Power Supply Current		62	100	mA	V _{CC} = MAX.

NOTES:

- (1) The actual testing procedures used to guarantee the Electrical Characteristics are contained in a detailed Customer Sample Specification. A copy of this specification can be obtained from Fairchild Digital Product Marketing, Mountain View, California.
- (2) Conditions for testing, not shown in the Table, are chosen to guarantee operation under "worst case" conditions.
- (3) The specified LIMITS represent the "worst case" value for the parameter. Since these "worst case" values normally occur at the temperature and supply voltage extremes, additional noise immunity and guard banding can be achieved by decreasing the allowable system operating ranges.
- (4) Typical limits are at V_{CC} = 5.0 V, 25°C, and maximum loading.
- (5) Not more than one output should be shorted at a time.

FAIRCHILD TTL/MSI • 9308

SWITCHING CHARACTERISTICS (T_A = 25°C)

SYMBOL	PARAMETER	9308XM(MIL)			9308XC(IND)			UNITS	TEST CONDITIONS	
		MIN.	TYP.	MAX.	MIN.	TYP.	MAX.			
t _{PLH}	Turn off Delay Enable to Output			30			35	ns	Fig. 1	V _{CC} = 5.0 V C _L = 15pF
t _{PHL}	Turn on Delay Enable to Output			18			22	ns		
t _{PLH}	Turn off Delay Data to Output			20			23	ns	Fig. 2	
t _{PHL}	Turn on Delay Data To Output			18			20	ns		
t _{PHL}	Turn on Delay \overline{MR} to Output			20			22	ns	Fig. 5	

SWITCHING SET-UP REQUIREMENTS (T_A = 25°C)

SYMBOL	PARAMETER	9308XM(MIL)			9308XC(IND)			UNITS	TEST CONDITIONS	
		MIN.	TYP.	MAX.	MIN.	TYP.	MAX.			
t _s (H)	Set-up Time HIGH Data to Enable	6.0	1.0		10	1.0		ns	Fig. 3	V _{CC} = 5.0 V
t _h (H)	Hold Time HIGH Data to Enable	-4.0	-7.0		-2.0	-7.0		ns		
t _s (L)	Set-up Time LOW Data to Enable	10	7.0		12	7.0		ns		
t _h (L)	Hold Time LOW Data to Enable	4.0	-1.0		8.0	-1.0		ns		
t _{pw} \overline{E}	Enable Pulse Width	15			18			ns	Fig. 4	
t _{pw} \overline{MR}	Master Reset Pulse Width	15			18			ns	Fig. 5	
t _{rec}	Recovery Time Master Reset to Enable	10			12			ns	Fig. 6	

SET UP TIME: t_s is defined as the time required for the logic level to be present at the Data Input prior to the enable transition from LOW to HIGH in order for the latch to recognize and store the new data.

HOLD TIME: t_h is defined as the minimum time following the Enable transition from LOW to HIGH that the logic level must be maintained at the data input in order to insure continued recognition. A negative Hold Time indicates that the correct logic level may be released prior to the Enable transition from LOW to HIGH and still be recognized.

RECOVERY TIME: t_{rec} is defined as the time that the Enable must remain LOW after the Master Reset transition from LOW to HIGH in order for the latch to recognize and store HIGH data.

SWITCHING CHARACTERISTICS

All delays are measured with V_{CC} = 5.0 V applied to Pin 24 and Pin 12 grounded. Outputs under test are loaded with 15 pF (includes jig and probe). Pins not referenced are not connected.

Fig. 1 – t_{PLH}/t_{PHL} (ENABLE TO OUTPUT)

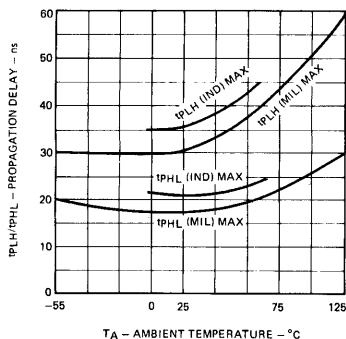
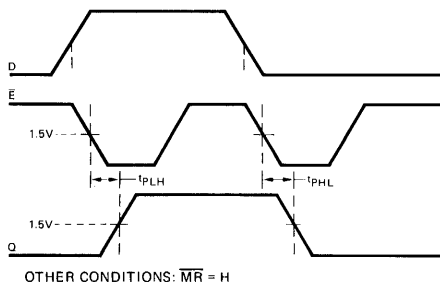
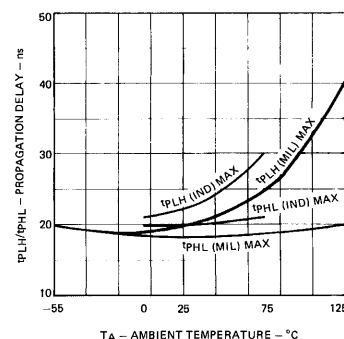
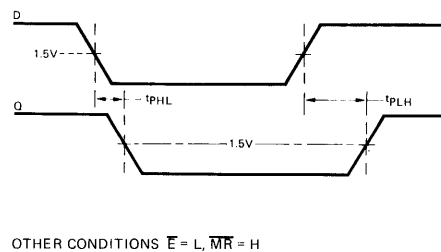
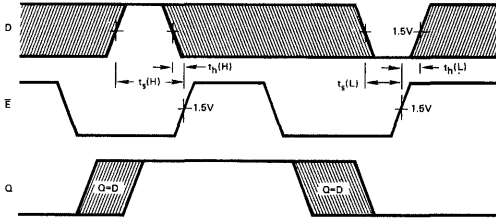

Fig. 2 – t_{PLH}/t_{PHL} (DATA TO OUTPUT)



SWITCHING CHARACTERISTICS

Fig. 3 – SET-UP TIME (t_s) AND HOLD TIME (t_h) DATA TO ENABLE



OTHER CONDITIONS: $\overline{MR} = H$

The shaded areas indicate when the Data input is permitted to change for predictable output performance.

NOTE: The polarities of the $t_h(H)$ and $t_h(L)$ values are inverted on the graphs. This representation allows the graphs to show the true distribution of the $t_{(set-up)}$ parameters.

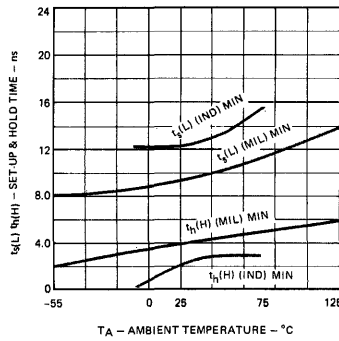
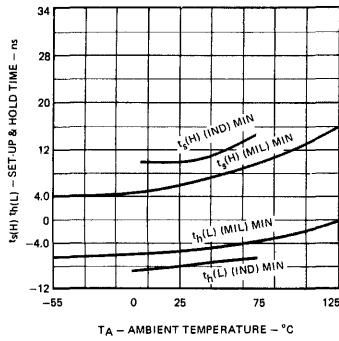
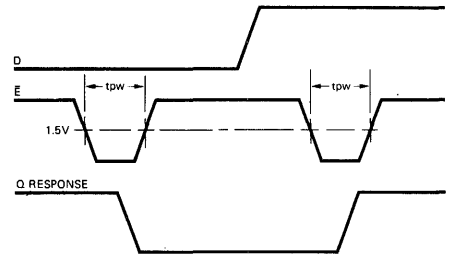

Fig. 4 – t_{pw} (MIN. ENABLE PULSE WIDTH)



OTHER CONDITION: $\overline{MR} = H$

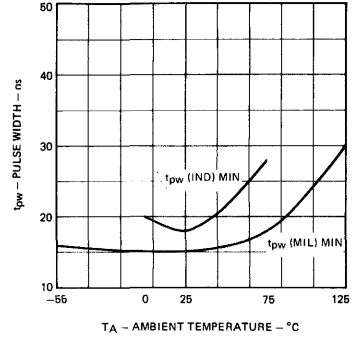
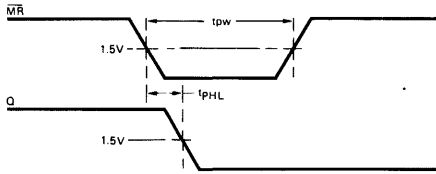

Fig. 5 – t_{pw} (MIN. MASTER RESET PULSE WIDTH) t_{PHL} (MASTER RESET TO OUTPUT)



OTHER CONDITIONS: $D = H, \overline{E} = L$

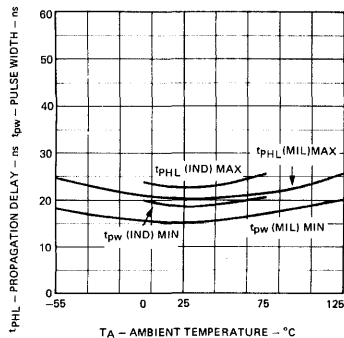
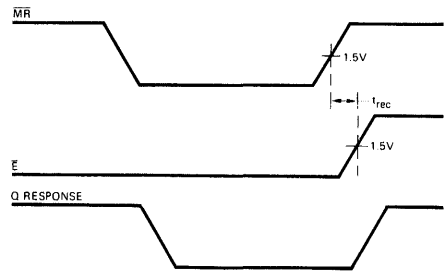
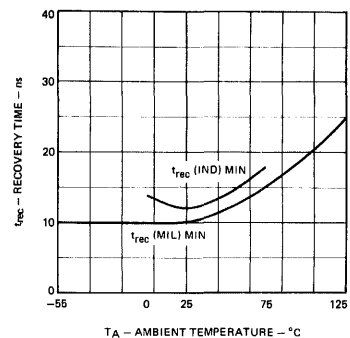

Fig. 6 – t_{rec} (MASTER RESET RECOVERY TIME)



OTHER CONDITIONS: $D = H$



LPTTL/MSI 93L08

LOW POWER DUAL FOUR-BIT LATCH

DESCRIPTION The LPTTL/MSI 93L08 is a Dual 4-Bit Latch designed for general purpose storage applications in medium speed digital systems. The 93L08 uses TTL technology and is TTL compatible. All inputs incorporate diode clamps to ground to reduce negative line transients. All outputs have active pull-up circuitry to provide high capacitive drive and low impedance outputs in both logic states to provide good ac noise immunity.

- ACTIVE LEVEL LOW ENABLE GATE INPUTS
- OVERRIDING MASTER RESET
- TYPICAL PROPAGATION DELAY OF 53 ns
- TYPICAL POWER DISSIPATION OF 100 mW
- INPUT CLAMP DIODES LIMIT HIGH SPEED TERMINATION EFFECTS
- ALL CERAMIC "HERMETIC" 24-LEAD DUAL IN-LINE AND FLAT PACKAGES
- TTL COMPATIBLE

PIN NAMES

D ₀ , D ₁ , D ₂ , D ₃	Parallel Latch Inputs
\bar{E}	AND Enable (Active LOW) Inputs
\bar{MR}	Master Reset (Active LOW) Input
Q ₀ , Q ₁ , Q ₂ , Q ₃	Parallel Latch Outputs

1 Unit Load (U.L.) = 40 μ A HIGH/1.6 mA LOW

LOADING	
HIGH	LOW
0.75 U.L.	0.375 U.L.
0.5 U.L.	0.25 U.L.
0.5 U.L.	0.25 U.L.
9.0 U.L.	2.25 U.L.

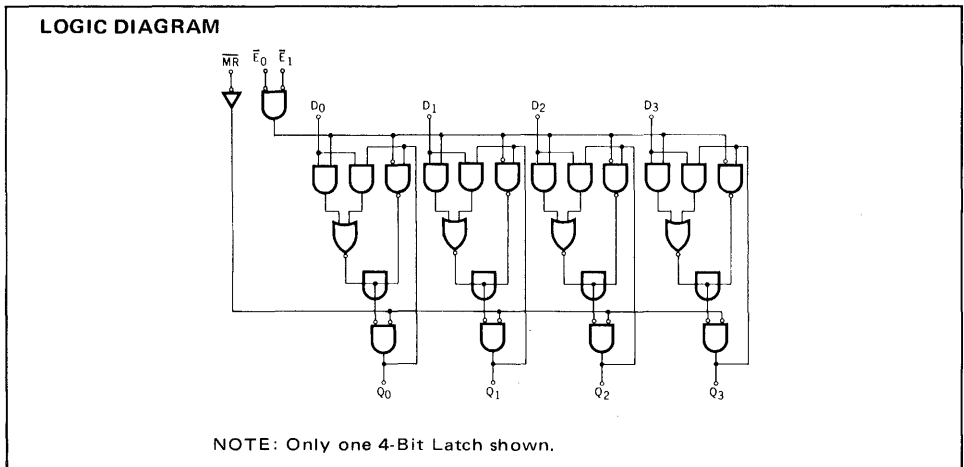
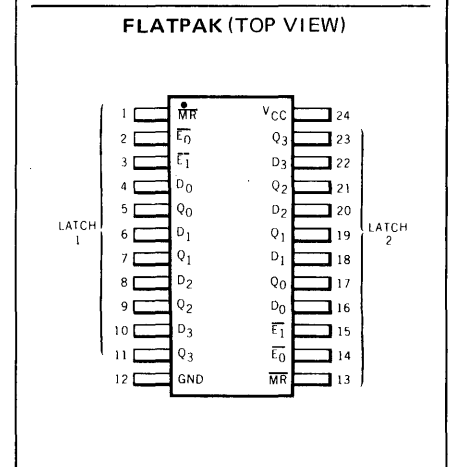
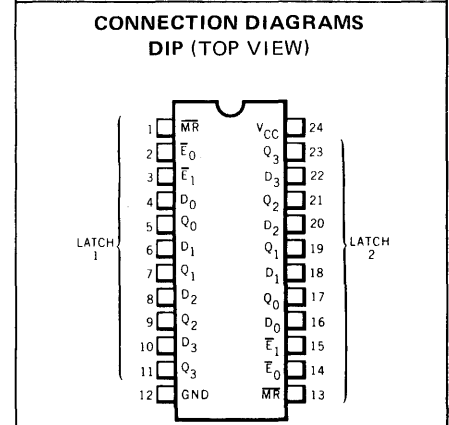
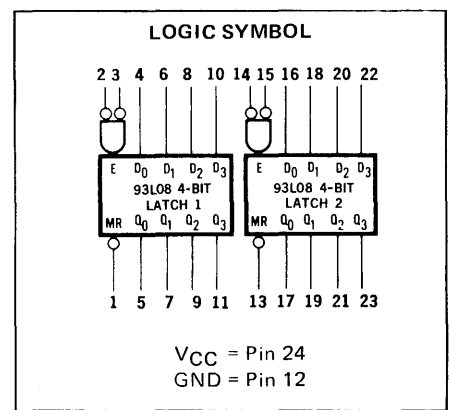

FAIRCHILD LPTTL/MSI • 93L08

LATCH OPERATION — Data can be entered into the latch when both of the enable inputs are LOW. As long as this logic condition exists, the output of the latch will follow the input. If either of the enable inputs goes HIGH, the data present in the latch at that time is held in the latch and is no longer affected by data input.

The master reset overrides all other input conditions and forces the outputs of all the latches LOW when a LOW signal is applied to the master reset input.

TRUTH TABLE

\overline{MR}	\overline{E}_0	\overline{E}_1	D	Q_0	OPERATION
H	L	L	L	L	Data Entry
H	L	L	H	H	Data Entry
H	L	H	X	Q_{n-1}	Hold
H	H	L	X	Q_{n-1}	Hold
H	H	H	X	Q_{n-1}	Hold
L	X	X	X	L	Reset

X = Don't Care

L = LOW Voltage Level

H = HIGH Voltage Level

Q_{n-1} = Previous Output State

Q_n = Present Output State

ABSOLUTE MAXIMUM RATINGS (above which the useful life may be impaired)

Storage Temperature	-65°C to +150°C
Temperature (Ambient) Under Bias	-55°C to +125°C
V _{CC} Pin Potential to Ground Pin	-0.5 V to +7.0 V
*Input Voltage (dc)	-0.5 V to +5.5 V
*Input Current (dc)	-30 mA to +5.0 mA
Voltage Applied to Outputs (Output HIGH)	-0.5 V to +V _{CC} value
Output Current (dc) (Output LOW)	+30 mA

*Either Input Voltage limit or Input Current limit is sufficient to protect the inputs.

GUARANTEED OPERATING RANGES

PART NUMBER	SUPPLY VOLTAGE (V _{CC})			TEMPERATURE
	MIN.	TYP.	MAX.	
93L08XM	4.5 V	5.0 V	5.5 V	-55°C to 125°C
93L08XC	4.75 V	5.0 V	5.25 V	0°C to 75°C

X = package type; F for Flatpak, D for Ceramic Dip, P for Plastic Dip. See Packaging Information Section for packages available on this product.

ELECTRICAL CHARACTERISTICS OVER OPERATING TEMPERATURE RANGE (unless otherwise noted)

SYMBOL	PARAMETER	LIMITS			UNITS	CONDITIONS
		MIN.	TYP. (Note 5)	MAX.		
V _{OH}	Output HIGH Voltage	2.4	3.6		Volts	V _{CC} = MIN., I _{OH} = -0.36 mA V _{IN} = V _{IH} or V _{IL} per Truth Table
V _{OL}	Output LOW Voltage		0.15	0.3	Volts	V _{CC} = MIN., I _{OL} = 3.6 mA V _{IN} = V _{IH} or V _{IL} per Truth Table
V _{IH}	Input HIGH Voltage	2.0			Volts	Guaranteed Input HIGH Threshold Voltage for All Inputs
V _{IL}	Input LOW Voltage			0.7	Volts	Guaranteed Input LOW Threshold Voltage for All Inputs
I _{IL}	Input LOW Current $\overline{E}_0, \overline{E}_1$ & \overline{MR}		-0.25	-0.4	mA	V _{CC} = MAX., V _{IN} = 0.3 V
	Input LOW Current D ₀ , D ₁ , D ₂ & D ₃		-0.38	-0.64	mA	V _{CC} = MAX., V _{IN} = 0 V (See Note 4)
I _{IH}	Input HIGH Current $\overline{E}_0, \overline{E}_1$ & \overline{MR}		2.0	20	μA	V _{CC} = MAX., V _{IN} = 2.4 V
	Input HIGH Current D ₀ , D ₁ , D ₂ & D ₃		3.0	30		
	Input HIGH Current			1.0	mA	V _{CC} = MAX., V _{IN} = 5.5 V
I _{SC} (Note 6)	Output Short Circuit Current	-2.5	-16	-25	mA	V _{CC} = MAX., V _{OUT} = 0 V
I _{CC}	Power Supply Current		20	33	mA	V _{CC} = MAX., All Outputs LOW, Pins 2 & 14 GND, Other Inputs Open

NOTES:

1. The actual testing procedures used to guarantee the Electrical Characteristics are contained in a detailed Customer Sample Specification. A copy of this specification can be obtained from Fairchild Digital Product Marketing, Mountain View, California.
2. Conditions for testing, not shown in the table, are chosen to guarantee operation under "worst case" conditions.
3. The specified LIMITS represent the "worst case" value for the parameter. Since these "worst case" values normally occur at the temperature and supply voltage extremes, additional noise immunity and guard banding can be achieved by decreasing the allowable system operating ranges.
4. This current is measured at $V_{IN} = 0\text{ V}$ to insure that no current is being absorbed by the device internally. The maximum value given guarantees that the maximum instantaneous current that can flow out of the input at $V_{IN} = 0.3\text{ V}$ is 0.6 mA.
5. Typical limits are at $V_{CC} = 5.0\text{ V}$, 25°C , and maximum loading.
6. Not more than one output should be shorted at a time.

SWITCHING CHARACTERISTICS ($T_A = 25^\circ\text{C}$)

SYMBOL	CHARACTERISTIC	LIMITS			UNITS	CONDITIONS
		MIN.	TYP.	MAX.		
t_{PLH}	Enable to Output		35	60	ns	Fig. 1
t_{PHL}	Enable to Output		30	50		
t_{PLH}	Data to Output		30	50	ns	Fig. 2
t_{PHL}	Data to Output		35	55		
t_{PHL}	Master Reset to Output		31	55	ns	Fig. 5

$V_{CC} = 5.0\text{ V}$
 $C_L = 15\text{ pF}$

SWITCHING SET-UP REQUIREMENTS ($T_A = 25^\circ\text{C}$)

t_s (H)	HIGH Data to Enable	25	15	ns	Fig. 3
t_s (L)	LOW Data to Enable	35	22		
t_h (H)	HIGH Data to Enable	0		ns	Fig. 3
t_h (L)	LOW Data to Enable	0			
t_{pw} \overline{E}	Enable Pulse Width	45	30	ns	Fig. 4
t_{pw} \overline{MR}	Master Reset Pulse Width	40	25	ns	Fig. 5
t_{rec}	Master Reset Recovery Time	30		ns	Fig. 6

$V_{CC} = 5.0\text{ V}$

SET UP TIME: t_s is defined as the time required for the logic level to be present at the data input prior to the enable transition from LOW to HIGH in order for the latch to recognize and store the new data.

HOLD TIME: t_h is defined as the minimum time following the Enable transition from LOW to HIGH that the logic level must be maintained at the data input in order to insure continued recognition. A negative Hold Time indicates that the correct logic level may be released prior to the Enable transition from LOW to HIGH and still be recognized.

RECOVERY TIME: t_{rec} is defined as the time that the enable must remain LOW after the master reset transition from LOW to HIGH in order for the latch to recognize and store HIGH data.

SWITCHING WAVEFORMS

t_{PLH}/t_{PHL} (ENABLE TO OUTPUT)

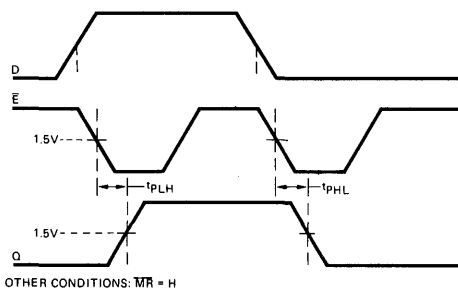

OTHER CONDITIONS: $\overline{MR} = H$

Fig. 1

t_{PLH}/t_{PHL} (DATA TO OUTPUT)

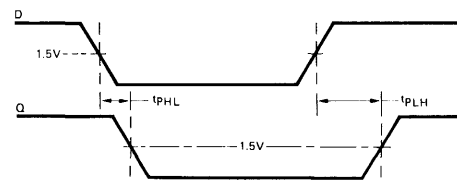

OTHER CONDITIONS: $\overline{E} = L, \overline{MR} = H$

Fig. 2

SWITCHING WAVEFORMS (Cont'd)

SETUP TIME (t_s) AND HOLD TIME (t_h) DATA TO ENABLE

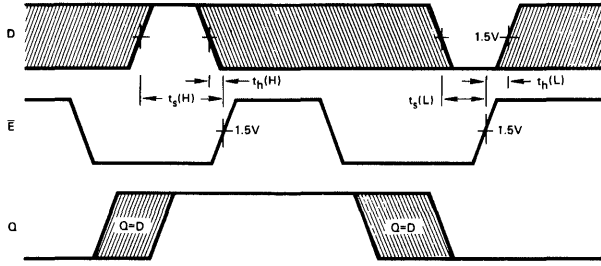

OTHER CONDITIONS: $\overline{MR} = H$

The shaded areas indicate when the Data input is permitted to change to predictable output performance.

Fig. 3

t_{pw} (MIN. ENABLE PULSE WIDTH)

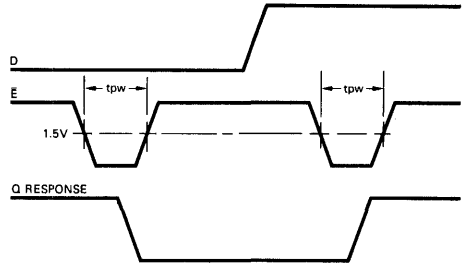

OTHER CONDITIONS: $\overline{MR} = H$

Fig. 4

t_{pw} (MIN. MASTER RESET PULSE WIDTH)
 t_{PHL} (MASTER RESET TO OUTPUT)

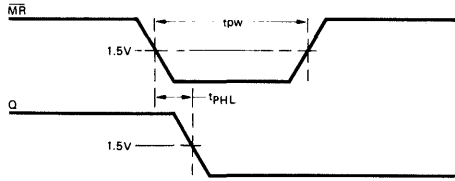

OTHER CONDITIONS: $D = H, \overline{E} = L$

Fig. 5

t_{rec} (MASTER RESET RECOVERY TIME)

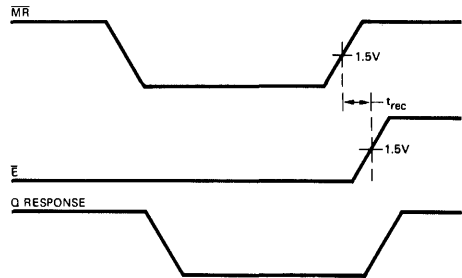

OTHER CONDITIONS: $D = H$

Fig. 6

TTL/MSI 9309

DUAL FOUR-INPUT MULTIPLEXER

DESCRIPTION — The 9309 is a monolithic, high speed, Dual Four-Input digital Multiplexer circuit, consisting of two multiplexing circuits with common input select logic. Each circuit contains four inputs and fully buffered complementary outputs. In addition to multiplexer operation, the 9309 can generate any two function of three variables. Active pullups in the outputs ensure high drive and high speed performance. Because of its high speed performance and on-chip select decoding, the 9309 may be cascaded to multiple levels so that any number of lines can be multiplexed onto a single output buss. The circuit uses TTL for high speed, high fan out operation and is compatible with all other members of the Fairchild TTL family.

- **MULTIFUNCTION CAPABILITY**
- **25 ns THROUGH DELAY**
- **ON-CHIP SELECT LOGIC DECODING**
- **FULLY BUFFERED COMPLEMENTARY OUTPUTS**
- **THE INPUT/OUTPUT CHARACTERISTICS PROVIDE EASY INTERFACING WITH FAIRCHILD DTL, LPDTL, TTL, AND MSI FAMILIES**
- **INPUT CLAMP DIODES LIMIT HIGH SPEED TERMINATION EFFECTS**

PIN NAMES

S_0, S_1	Common Select Inputs	
Multiplexer A		
$I_{0a}, I_{1a}, I_{2a}, I_{3a}$	Multiplexer Inputs	
Z_a	Multiplexer Output (Note b)	
\bar{Z}_a	Complementary Multiplexer Output (Note c)	
Multiplexer B		
$I_{0b}, I_{1b}, I_{2b}, I_{3b}$	Multiplexer Inputs	
Z_b	Multiplexer Output (Note b)	
\bar{Z}_b	Complementary Multiplexer Output (Note c)	

LOADING

(Note a)

	1 U.L.
	1 U.L.
	10 U.L.
	9 U.L.
	1 U.L.
	10 U.L.
	9 U.L.

NOTES:

- 1 Unit Load (U.L.) = 40 μ A HIGH/1.6mA LOW.
- 10 U.L. is the output LOW drive factor and 20 U.L. is the output HIGH drive factor.
- 9 U.L. is the output LOW drive factor and 18 U.L. is the output HIGH drive factor.

LOGIC DIAGRAM

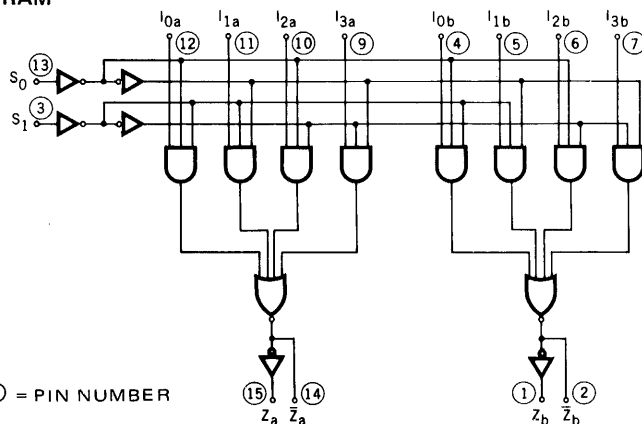

LOGIC SYMBOL

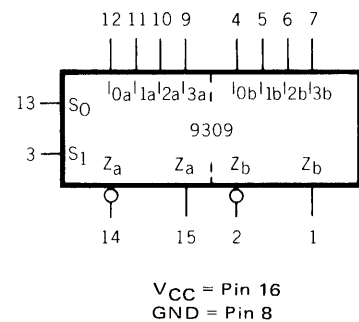

CONNECTION DIAGRAMS

DIP (TOP VIEW)

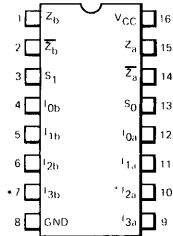

FLATPAK (TOP VIEW)

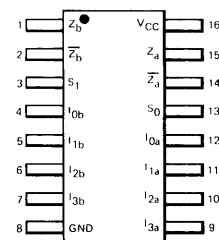

FUNCTIONAL DESCRIPTION — The 9309 dual four-input multiplexer is a member of the Fairchild family of compatible medium scale integrated (MSI) digital building blocks. It provides this family with the ability to select two bits of either data or control from up to four sources, in one package.

The 9309 dual four-input multiplexer is the logical implementation of a two-pole four-position switch, with the position of the switch being set by the logic levels supplied to the two select inputs. Both assertion and negation outputs are provided for both multiplexers. The logic equations for the outputs are shown below:

$$Z_a = I_{0a} \cdot \bar{S}_1 \cdot \bar{S}_0 + I_{1a} \cdot \bar{S}_1 \cdot S_0 + I_{2a} \cdot S_1 \cdot \bar{S}_0 + I_{3a} \cdot S_1 \cdot S_0$$

$$Z_b = I_{0b} \cdot \bar{S}_1 \cdot \bar{S}_0 + I_{1b} \cdot \bar{S}_1 \cdot S_0 + I_{2b} \cdot S_1 \cdot \bar{S}_0 + I_{3b} \cdot S_1 \cdot S_0$$

A common use of the 9309 would be the moving of data from a group of registers to a common output buss. The particular register from which the data came would be determined by the state of the select inputs. A less obvious use is as a function generator. The 9309 can generate any two functions of three variables. This is useful for implementing random gating functions.

TRUTH TABLE

SELECT INPUTS		INPUTS				OUTPUTS	
S ₀	S ₁	I _{0a}	I _{1a}	I _{2a}	I _{3a}	Z _a	\bar{Z}_a
L	L	L	X	X	X	L	H
L	L	H	X	X	X	H	L
H	L	X	L	X	X	L	H
H	L	X	H	X	X	H	L
L	H	X	X	L	X	L	H
L	H	X	X	H	X	H	L
H	H	X	X	X	L	L	H
H	H	X	X	X	H	H	L
S ₀	S ₁	I _{0b}	I _{1b}	I _{2b}	I _{3b}	Z _b	\bar{Z}_b
L	L	L	X	X	X	L	H
L	L	H	X	X	X	H	L
H	L	X	L	X	X	L	H
H	L	X	H	X	X	H	L
L	H	X	X	L	X	L	H
L	H	X	X	H	X	H	L
H	H	X	X	X	L	L	H
H	H	X	X	X	H	H	L

L = LOW Voltage Level
 H = HIGH Voltage Level
 X = Either HIGH or LOW Logic Level

TYPICAL INPUT AND OUTPUT CHARACTERISTICS

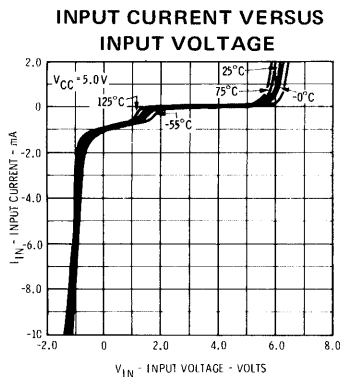
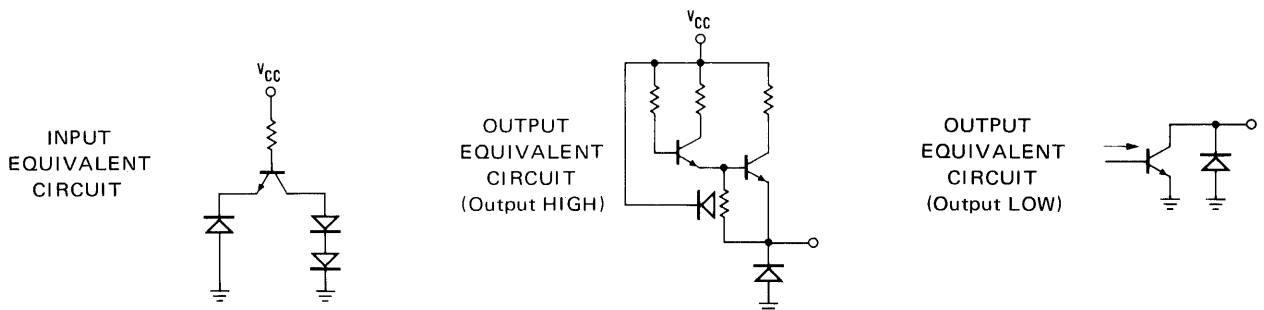

Fig. 1

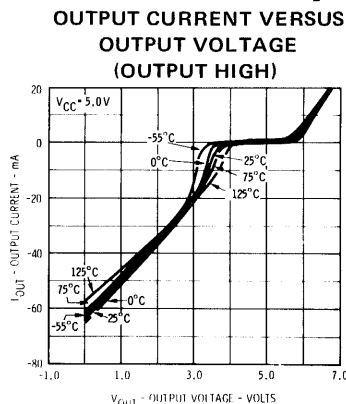

Fig. 2

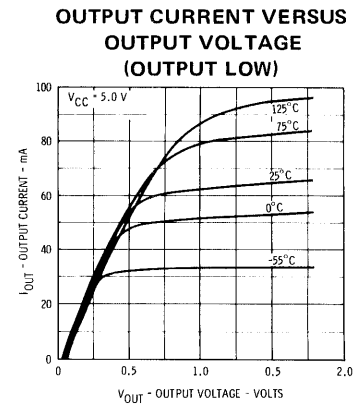

Fig. 3

ABSOLUTE MAXIMUM RATINGS (above which the useful life may be impaired)

Storage Temperature	-65°C to +150°C
Temperature (Ambient) Under Bias	-55°C to +125°C
V _{CC} Pin Potential to Ground Pin	-0.5V to +7.0V
*Input Voltage (dc)	-0.5V to +5.5V
*Input Current (dc)	-30mA to +5.0mA
Voltage Applied to Outputs (Output HIGH)	-0.5V to +V _{CC} value
Output Current (dc) (Output LOW)	+30 mA

*Either Input Voltage Limit or Input Current is sufficient to protect the inputs.

GUARANTEED OPERATING RANGES

PART NUMBER	SUPPLY VOLTAGE (V _{CC})			TEMPERATURE
	MIN.	TYP.	MAX.	
9309XM	4.5 V	5.0 V	5.5 V	-55°C to 125°C
9309XC	4.75 V	5.0 V	5.25 V	0°C to 75°C

X = package type; F for Flatpak, D for Ceramic Dip, P for Plastic Dip. See Packaging Information Section for packages available on this product.

ELECTRICAL CHARACTERISTICS OVER OPERATING TEMPERATURE RANGE (unless otherwise noted)

SYMBOL	PARAMETER	LIMITS			UNITS	CONDITIONS
		MIN	TYP (Note 4)	MAX		
V _{IH}	Input HIGH Voltage	2.0			Volts	Guaranteed Input HIGH Threshold Voltage for all Inputs
V _{IL}	Input LOW Voltage			0.8	Volts	Guaranteed Input LOW Threshold Voltage for all Inputs
V _{CD}	Input Clamp Diode Voltage			-1.5	Volts	V _{CC} = MIN., I _{IN} = -12 mA, T _A = 25°C
V _{OH}	Output HIGH Voltage	2.4	3.6		Volts	V _{CC} = MIN., I _{OH} = -800 μA V _{IN} = V _{IH} or V _{IL} per Truth Table
V _{OL}	Output LOW Voltage		0.2	0.4	Volts	V _{CC} = MIN., I _{OL} = 16 mA V _{IN} = V _{IH} or V _{IL} per Truth Table
I _{IH}	Input HIGH Current		10	40	μA	V _{CC} = MAX., V _{IN} = 2.4 V
				1.0	mA	V _{CC} = MAX., V _{IN} = 5.5 V
I _{IL}	Input LOW Current		-0.96	-1.6	mA	V _{CC} = MAX., V _{IN} = 0.4 V
I _{SC} (I _{O5})	Output Short Circuit Current (Note 5)	-20	-40	-70	mA	V _{CC} = MAX., V _{OUT} = 0.0 V
I _{CC}	Power Supply Current		30	44	mA	V _{CC} = MAX.

NOTES:

- (1) The actual testing procedures used to guarantee the Electrical Characteristics are contained in a detailed Customer Sample Specification. A copy of this specification can be obtained from Fairchild Digital Product Marketing, Mountain View, California.
- (2) Conditions for testing, not shown in the Table, are chosen to guarantee operation under "worst case" conditions.
- (3) The specified LIMITS represent the "worst case" value for the parameter. Since these "worst case" values normally occur at the temperature and supply voltage extremes, additional noise immunity and guard banding can be achieved by decreasing the allowable system operating ranges.
- (4) Typical limits are at V_{CC} = 5.0V, 25°C and maximum loading.
- (5) Not more than one output should be shorted at a time.

SWITCHING CHARACTERISTICS (T_A = 25°C)

SYMBOL	PARAMETER	LIMITS			UNITS	TEST CONDITIONS
		MIN.	TYP.	MAX.		
t _{PLH}	Turn Off Delay Input to Output (S ₀ to Z _a)		24	32	ns	V _{CC} = 5.0 V C _L = 15 pF (See Fig. 4)
t _{PHL}	Turn On Delay Input to Output (S ₀ to Z _a)		24	32	ns	

SWITCHING CHARACTERISTICS

Fig. 4

t_{PLH}/t_{PHL} S_0 to Z_a

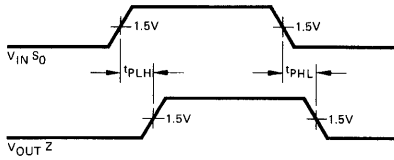

TURN OFF DELAY TIME VERSUS AMBIENT TEMPERATURE (S_0 to Z_a)

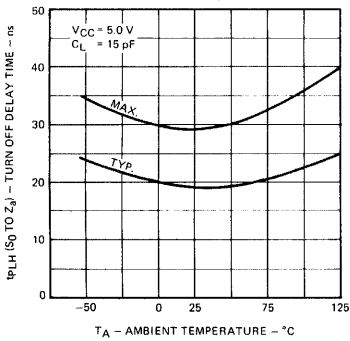

TURN ON DELAY TIME VERSUS TEMPERATURE (S_0 to Z_a)

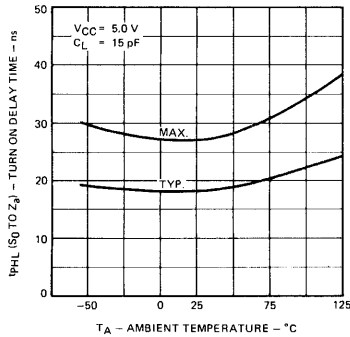
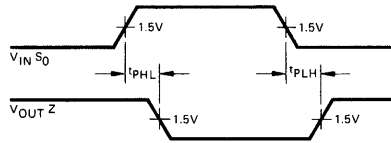
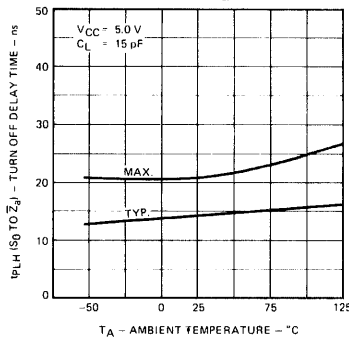

Fig. 5

t_{PLH}/t_{PHL} S_0 to \bar{Z}_a



TURN OFF DELAY TIME VERSUS AMBIENT TEMPERATURE (S_0 to \bar{Z}_a)



TURN ON DELAY TIME VERSUS AMBIENT TEMPERATURE (S_0 to \bar{Z}_a)

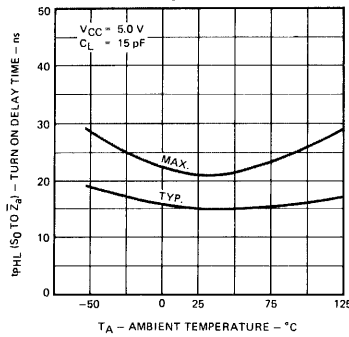
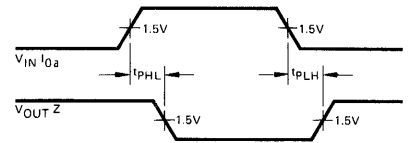
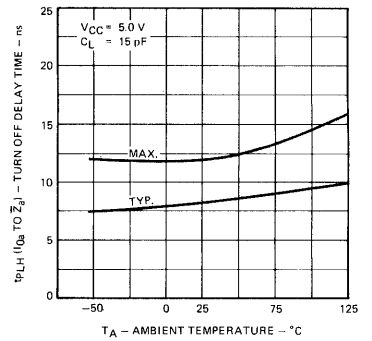

Fig. 6

t_{PLH}/t_{PHL} I_{0a} to \bar{Z}_a



TURN OFF DELAY TIME VERSUS AMBIENT TEMPERATURE (I_{0a} to \bar{Z}_a)



TURN ON DELAY TIME VERSUS AMBIENT TEMPERATURE (I_{0a} to \bar{Z}_a)

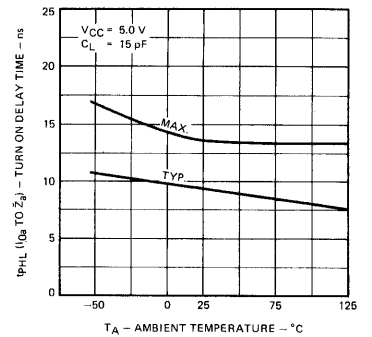

LPTTL/MSI 93L09

LOW POWER DUAL FOUR-INPUT MULTIPLEXER

DESCRIPTION – The LPTTL/MSI 93L09 is a Monolithic, Medium Speed, Dual 4-Input Digital Multiplexer. It consists of two multiplexing circuits with common input select logic. Each circuit contains four inputs and fully buffered complementary outputs. In addition to operating as a multiplexer, the 93L09 can generate two functions of three variables. Active pullups in the outputs ensure good drive and speed performance. The 93L09 may be cascaded to multiple levels so that any number of lines can be multiplexed onto a single output buss. The circuit uses TTL technology and is compatible with all other members of the TTL family.

- MULTIFUNCTION CAPABILITY
- ON-CHIP SELECT LOGIC DECODING
- TYPICAL PROPAGATION DELAY OF 48 ns
- TYPICAL POWER DISSIPATION OF 40 mW
- INPUT CLAMP DIODES LIMIT HIGH SPEED TERMINATION EFFECTS
- ALL CERAMIC "HERMETIC" 16-LEAD DUAL IN-LINE AND FLAT PACKAGES
- TTL COMPATIBLE

PIN NAMES

		LOADING	
		HIGH	LOW
S_0, S_1	Common Select Inputs	0.5 U.L.	0.25 U.L.
Multiplexer A			
$I_{0a}, I_{1a}, I_{2a}, I_{3a}$	Multiplexer Inputs	0.5 U.L.	0.25 U.L.
Z_a	Multiplexer Output	10 U.L.	2.5 U.L.
\bar{Z}_a	Complementary Multiplexer Output	10 U.L.	2.25 U.L.
Multiplexer B			
$I_{0b}, I_{1b}, I_{2b}, I_{3b}$	Multiplexer Inputs	0.5 U.L.	0.25 U.L.
Z_b	Multiplexer Output	10 U.L.	2.5 U.L.
\bar{Z}_b	Complementary Multiplexer Output	10 U.L.	2.25 U.L.

1 Unit Load (U.L.) = 40 μ A HIGH/1.6 mA LOW

LOGIC DIAGRAM

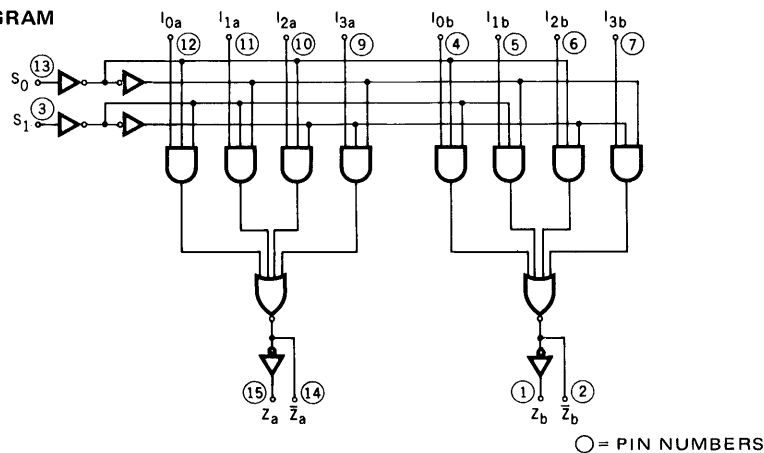

LOGIC SYMBOL

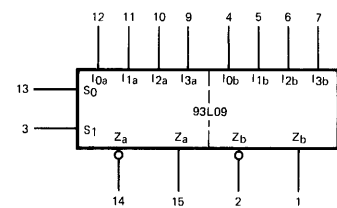

V_{CC} = Pin 16
GND = Pin 8

CONNECTION DIAGRAMS DIP (TOP VIEW)

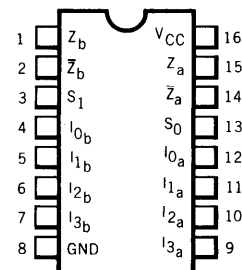

FLATPAK (TOP VIEW)

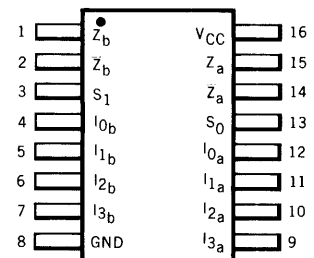

FAIRCHILD LPTTL/MSI • 93L09

FUNCTIONAL DESCRIPTION — The 93L09 dual 4-input multiplexer is a member of the Fairchild family of compatible low power medium scale integrated digital building blocks. It provides this family with the ability to select two bits of either data or control from up to four sources, in one package.

The 93L09 is the logical implementation of two-pole, four-position switch, with the position of the switch being set by the logic levels supplied to the two select inputs. Both assertion and negation outputs are provided for both multiplexers. The logic equations for the outputs are shown below:

$$Z_a = I_{0a} \cdot \bar{S}_1 \cdot \bar{S}_0 + I_{1a} \cdot \bar{S}_1 \cdot S_0 + I_{2a} \cdot S_1 \cdot \bar{S}_0 + I_{3a} \cdot S_1 \cdot S_0$$

$$Z_b = I_{0b} \cdot \bar{S}_1 \cdot \bar{S}_0 + I_{1b} \cdot \bar{S}_1 \cdot S_0 + I_{2b} \cdot S_1 \cdot \bar{S}_0 + I_{3b} \cdot S_1 \cdot S_0$$

The 93L09 is frequently used to move data from a group of registers to a common output buss. The particular register from which the data came would be determined by the state of the select inputs. A less obvious application is as a function generator. The 93L09 can generate two functions of three variables. This is useful for implementing random gating functions.

TRUTH TABLE

SELECT INPUTS		INPUTS				OUTPUTS	
S ₀	S ₁	I _{0a}	I _{1a}	I _{2a}	I _{3a}	Z _a	Z _a
L	L	L	X	X	X	L	H
L	L	H	X	X	X	H	L
H	L	X	L	X	X	L	H
H	L	X	H	X	X	H	L
L	H	X	X	L	X	L	H
L	H	X	X	H	X	H	L
H	H	X	X	X	L	L	H
H	H	X	X	X	H	H	L
<hr/>							
S ₀	S ₁	I _{0b}	I _{1b}	I _{2b}	I _{3b}	Z _b	Z _b
L	L	L	X	X	X	L	H
L	L	H	X	X	X	H	L
H	L	X	L	X	X	L	H
H	L	X	H	X	X	H	L
L	H	X	X	L	X	L	H
L	H	X	X	H	X	H	L
H	H	X	X	X	L	L	H
H	H	X	X	X	H	H	L

L = LOW Voltage Level
 H = HIGH Voltage Level
 X = Either HIGH or LOW Logic Level

TYPICAL INPUT AND OUTPUT CIRCUITS

INPUT EQUIVALENT CIRCUIT

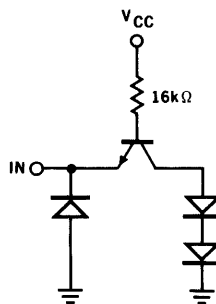

OUTPUT EQUIVALENT CIRCUIT (Output LOW)

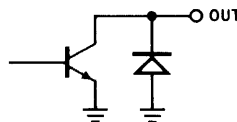

OUTPUT EQUIVALENT CIRCUIT (Output HIGH)

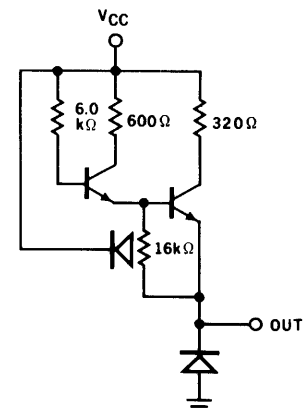

FAIRCHILD LPTTL/MSI • 93L09

ABSOLUTE MAXIMUM RATINGS (above which the useful life may be impaired)

Storage Temperature	-65°C to +150°C
Temperature (Ambient) Under Bias	-55°C to +125°C
V _{CC} Pin Potential to Ground Pin	-0.5 V to +7.0 V
*Input Voltage (dc)	-0.5 V to +5.5 V
*Input Current (dc)	-30 mA to +5.0 mA
Voltage Applied to Outputs (Output HIGH)	-0.5 V to +V _{CC} value
Output Current (dc) (Output LOW)	+30 mA

*Either Input Voltage limit or Input Current limit is sufficient to protect the inputs.

GUARANTEED OPERATING RANGES

PART NUMBER	SUPPLY VOLTAGE (V _{CC})			TEMPERATURE
	MIN.	TYP.	MAX.	
93L09XM	4.5 V	5.0 V	5.5 V	-55°C to 125°C
93L09XC	4.75 V	5.0 V	5.25 V	0°C to 75°C

X = package type; F for Flatpak, D for Ceramic Dip, P for Plastic Dip. See Packaging Information Section for packages available on this product.

ELECTRICAL CHARACTERISTICS OVER OPERATING TEMPERATURE RANGE (unless otherwise noted)

SYMBOL	PARAMETER	LIMITS			UNITS	CONDITIONS
		MIN.	TYP. (Note 4)	MAX.		
V _{OH}	Output HIGH Voltage	2.4	3.6		Volts	V _{CC} = MIN., I _{OH} = -0.4 mA V _{IN} = V _{IH} or V _{IL} per Truth Table
V _{OL}	Output LOW Voltage		0.15	0.3	Volts	V _{CC} = MIN., I _{OL} = 4.0 mA (Pins 1 & 15) I _{OL} = 3.6 mA (Pins 2 & 14) V _{IN} = V _{IH} or V _{IL} per Truth Table
V _{IH}	Input HIGH Voltage	2.0			Volts	Guaranteed Input HIGH Threshold Voltage for All Inputs
V _{IL}	Input LOW Voltage			0.7	Volts	Guaranteed Input LOW Threshold Voltage for All Inputs
I _{IL}	Input LOW Current		-0.25	-0.4	mA	V _{CC} = MAX., V _{IN} = 0.3 V
I _{IH}	Input HIGH Current		2.0	20	μA	V _{CC} = MAX., V _{IN} = 2.4 V
				1.0	mA	V _{CC} = MAX., V _{IN} = 5.5 V
I _{SC}	Output Short Circuit Current (Note 5)	-10	-26	-40	mA	V _{CC} = MAX., V _{OUT} = 0 V
I _{CC}	Power Supply Current		7.5	11.5	mA	V _{CC} = MAX.

NOTES:

- The actual testing procedures used to guarantee the Electrical Characteristics are contained in a detailed Customer Sample Specification. A copy of this specification can be obtained from Fairchild Digital Product Marketing, Mountain View, California.
- Conditions for testing, not shown in the table, are chosen to guarantee operation under "worst case" conditions.
- The specified LIMITS represent the "worst case" value for the parameter. Since these "worst case" values normally occur at the temperature and supply voltage extremes, additional noise immunity and guard banding can be achieved by decreasing the allowable system operating ranges.
- Typical limits are at V_{CC} = 5.0 V, 25°C, and maximum loading.
- Not more than one output should be shorted at a time.

SWITCHING CHARACTERISTICS (T_A = 25°C)

SYMBOL	PARAMETER	MIN.	TYP.	MAX.	UNITS	CONDITIONS
t _{PLH} (S ₀ to Z _a)	Turn Off Delay Input to Output		35	55	ns	V _{CC} = 5.0 V, C _L = 15 pF
t _{PHL} (S ₀ to Z _a)	Turn On Delay Input to Output		32	50	ns	

TTL/MSI 9310•9316

BCD DECADE COUNTER/4-BIT BINARY COUNTER

DESCRIPTION – The 9310 is a High Speed Synchronous BCD Decade Counter and the 9316 is a High Speed Synchronous 4-Bit Binary Counter. They are synchronously presettable, multifunctional MSI building blocks useful in a large number of counting, digital integration and conversion applications. Several stages of synchronous operation are obtainable with no external gating packages required through an internal carry lookahead counting technique.

- SYNCHRONOUS COUNTING AND PARALLEL ENTRY
- DECODED TERMINAL COUNT
- BUILT-IN CARRY CIRCUITRY
- TYPICAL COUNTING FREQUENCY OF 45 MHz
- TYPICAL POWER DISSIPATION OF 325 mW
- THE INPUT/OUTPUT CHARACTERISTICS PROVIDE EASY INTERFACING WITH FAIRCHILD DTL, LPDTL, AND TTL FAMILIES
- INPUT DIODE CLAMPING
- TTL COMPATIBLE

PIN NAMES

\overline{PE}	Parallel Enable (Active LOW) Input
P_0, P_1, P_2, P_3	Parallel Inputs
CEP	Count Enable Parallel Input
CET	Count Enable Trickle Input
CP	Clock (Active HIGH Going Edge) Input
\overline{MR}	Master Reset (Active LOW) Input
Q_0, Q_1, Q_2, Q_3	Parallel Outputs (Note b)
TC	Terminal Count Outputs (Note c)

LOADING (Note a)

\overline{PE}	2 U.L.
P_0, P_1, P_2, P_3	2/3 U.L.
CEP	1 U.L.
CET	2 U.L.
CP	2 U.L.
\overline{MR}	1 U.L.
Q_0, Q_1, Q_2, Q_3	8 U.L.
TC	10 U.L.

NOTES

- 1 Unit Load (U.L.) = 40 μ A HIGH/1.6 mA LOW
- 8 U.L. is the output LOW drive factor and 16 U.L. is the output HIGH drive factor.
- 10 U.L. is the output LOW drive factor and 20 U.L. is the output HIGH drive factor.

LOGIC SYMBOL

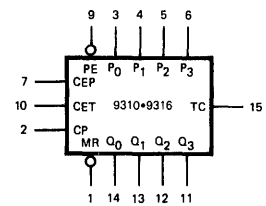

V_{CC} = Pin 16
GND = Pin 8

CONNECTION DIAGRAMS DIP (TOP VIEW)

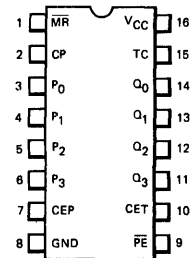

FLATPAK (TOP VIEW)

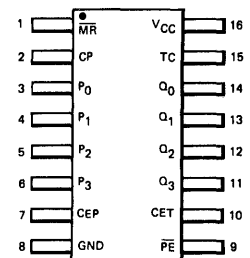

STATE DIAGRAM

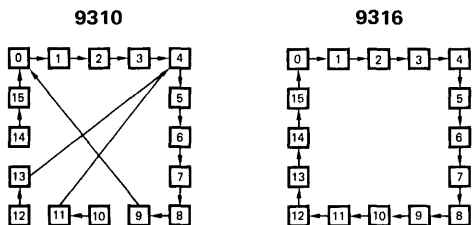

LOGIC EQUATIONS

Count Enable = $CEP \cdot CET \cdot PE$
 TC for 9310 = $CET \cdot Q_0 \cdot \overline{Q_1} \cdot \overline{Q_2} \cdot Q_3$
 TC for 9316 = $CET \cdot Q_0 \cdot Q_1 \cdot Q_2 \cdot Q_3$
 Preset = $\overline{PE} \cdot CP+$ (rising clock edge)
 Reset = \overline{MR}

NOTE:

The 9310 can be preset to any state, but will not count beyond 9. If preset to state 10, 11, 12, 13, 14, or 15, it will return to its normal sequence within two clock pulses.

FUNCTIONAL DESCRIPTION — The 9310 is a high speed BCD decade counter, and the 9316 is a high speed binary counter. Both counters are fully synchronous with the clock pulse driving four master/slave flip-flops in parallel through a clock buffer. During the LOW to HIGH transition of the clock, the master is inhibited from further change. After the masters are locked out, data is transferred from the master to the slaves and reflected at the outputs. When the clock is HIGH, the masters are inhibited and the master/slave data path remains established. During the HIGH to LOW transition of the clock, the slave is inhibited from further change, followed by the enabling of the masters for the acceptance of data from the counting logic or the parallel entry logic. (See Clock Pulse Characteristics Figure 7)

The three control inputs, Parallel Enable (\overline{PE}), Count Enable Parallel (CEP), and Count Enable Trickle (CET), select the mode of operation as shown in the tables below. When the conditions for counting are satisfied, the rising edge of a clock pulse will change the counters to the next state of the count sequence shown in the State Diagram on the previous page. The Count Mode is enabled when CEP and CET inputs and \overline{PE} are HIGH.

The 9310 and 9316 can be synchronously preset from the four Parallel inputs, (P_0 - P_3) when \overline{PE} is LOW. When the Parallel Enable and Clock are LOW, each master of the flip-flops is connected to the appropriate parallel input (P_0 - P_3) and the slaves (outputs) are steady in their previous state. When the clock goes HIGH, the masters are inhibited and this information is transferred to the slaves and reflected at the outputs. The parallel enable input overrides both count enable inputs, presetting the counter when LOW.

Terminal count is HIGH when the counter is at terminal count (state 9 for 9310, and state 15 for 9316), and Count Enable Trickle is HIGH, as is shown in the logic equations. Without additional logic, multistage synchronous counting at high speeds is made possible with a high speed lookahead technique utilizing the count enable and terminal count logic. A multistage counter illustrating these techniques is shown and discussed in the application section.

When LOW, the asynchronous master reset overrides all other inputs resetting the four outputs LOW.

Conventional operation of the 9310 • 9316, as shown in the Mode Selection table, requires that the mode control inputs (\overline{PE} , CEP, CET) are stable while the clock is LOW. This is no constraint for a normal synchronous system where all signals are generated by the rising edge of the clock.

For some applications, the designer may want to change those inputs while the clock is LOW. In this case the 9310 • 9316 will behave in a predictable manner. For example:

If \overline{PE} goes HIGH while the clock is LOW, but Count Enable is not active during the remaining clock LOW period (i.e. CEP or CET are LOW), the subsequent LOW to HIGH clock transition will change $Q_0 \dots Q_3$ to the $P_0 \dots P_3$ data that existed at the set-up time before the rising edge of \overline{PE} .

If Count Enable is active (i.e. CEP and CET are HIGH) during some portion of the clock LOW period, but \overline{PE} is HIGH (inactive) during the entire clock LOW period, the subsequent LOW to HIGH clock transition will change $Q_0 \dots Q_3$ to the next count value.

If \overline{PE} goes HIGH while the clock is LOW, but Count Enable is active (CEP and CET are HIGH) during some portion of the remaining clock LOW period, the 9310 • 9316 will perform a mixture of counting and loading. On the LOW to HIGH clock transition, outputs $Q_0 \dots Q_3$ will change as the count sequence or the loading requires. Only the outputs that would not change in the count sequence and are also reloaded with their present value stay constant.

**LOGIC DIAGRAM
9310**

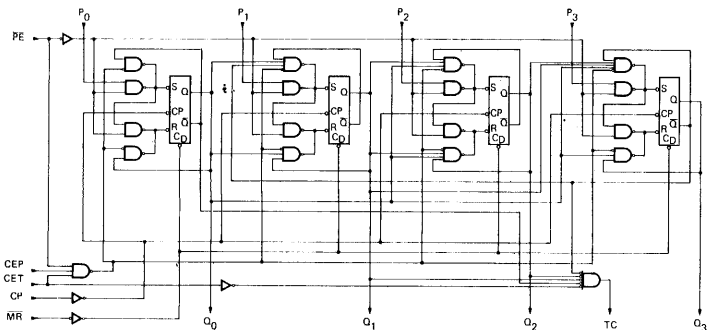

**9310 AND 9316
MODE SELECTION**

\overline{PE}	CEP	CET	MODE
L	L	L	Preset
L	L	H	Preset
L	H	L	Preset
L	H	H	Preset
H	L	L	No Change
H	L	H	No Change
H	H	L	No Change
H	H	H	Count

(\overline{MR} = HIGH)

9316

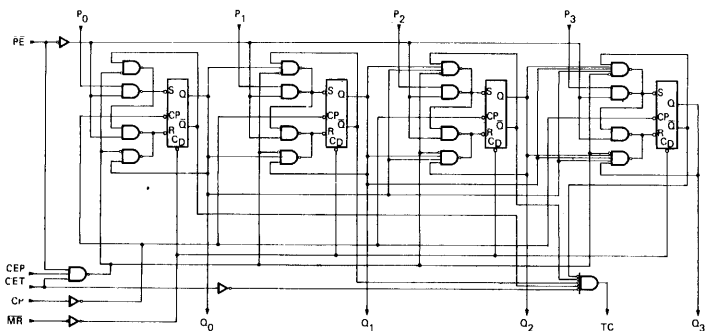

TERMINAL COUNT GENERATION

CET	9310	9316	TC
	$(Q_0 \cdot \overline{Q_1} \cdot \overline{Q_2} \cdot Q_3)$	$(Q_0 \cdot Q_1 \cdot Q_2 \cdot Q_3)$	
L	L	L	L
L	H	H	L
H	L	L	L
H	H	H	H

$TC = CET \cdot Q_0 \cdot \overline{Q_1} \cdot \overline{Q_2} \cdot Q_3$ (9310)

$TC = CET \cdot Q_0 \cdot Q_1 \cdot Q_2 \cdot Q_3$ (9316)

POSITIVE LOGIC = H = HIGH Voltage Level
L = LOW Voltage Level

FAIRCHILD TTL/MSI • 9310 • 9316

ABSOLUTE MAXIMUM RATINGS (above which the useful life may be impaired)

Storage Temperature	-65°C to +150°C
Temperature (Ambient) Under Bias	-55°C to +125°C
V _{CC} Pin Potential to Ground Pin	-0.5 V to +7.0 V
*Input Voltage (dc)	-0.5 V to +5.5 V
*Input Current (dc)	-30 mA to +5.0 mA
Voltage Applied to Outputs (Output HIGH)	-0.5 V to +V _{CC} value
Output Current (dc) (Output LOW)	+30 mA

*Either Input Voltage limit or Input Current limit is sufficient to protect the inputs.

GUARANTEED OPERATING RANGES

PART NUMBER	SUPPLY VOLTAGE (V _{CC})			TEMPERATURE
	MIN.	TYP.	MAX.	
9310XM • 9316XM	4.5 V	5.0 V	5.5 V	-55°C to 125°C
9310XC • 9316XC	4.75 V	5.0 V	5.25 V	0°C to 75°C

X=package type; F for Flatpak, D for Ceramic Dip, P for Plastic Dip. See Packaging Information Section for packages available on this product.

ELECTRICAL CHARACTERISTICS OVER OPERATING TEMPERATURE RANGE (unless otherwise noted)

SYMBOL	PARAMETER	LIMITS			UNITS	CONDITIONS
		MIN.	TYP. (Note 4)	MAX.		
V _{IH}	Input HIGH Voltage	2.0			Volts	Guaranteed Input Logical HIGH Voltage for all Inputs
V _{IL}	Input LOW Voltage			0.8	Volts	Guaranteed Input Logical LOW Voltage for all Inputs
V _{CD}	Input Clamp Diode Voltage			-1.5	Volts	V _{CC} = MIN., I _{IN} = -12 mA, T _A = 25°C
V _{OH}	Output HIGH Voltage	2.4	3.6		Volts	V _{CC} = MIN., I _{OH} = -640 μA for Q I _{OH} = -800 μA for TC V _{IN} = V _{IH} or V _{IL}
V _{OL}	Output LOW Voltage		0.2	0.4	Volts	V _{CC} = MIN., I _{OL} = 12.8 mA for Q I _{OL} = 16 mA for TC V _{IN} = V _{IH} or V _{IL}
I _{IH}	Input HIGH Current MR, CEP		10	40	μA	V _{CC} = MAX., V _{IN} = 2.4 V
	CP, PE, CET		20	80		
	P ₀ , P ₁ , P ₂ & P ₃		7	27		
	Input HIGH Current all Inputs			1.0	mA	V _{CC} = MAX., V _{IN} = 5.5 V
I _{IL}	Input LOW Current MR, CEP		-0.96	-1.6	mA	V _{CC} = MAX., V _{IN} = 0.4 V
	CP, PE, CET		-1.92	-3.2		
	P ₀ , P ₁ , P ₂ & P ₃		-0.64	-1.07		
I _{SC} (I _{OS})	Output Short Circuit Current (Note 5)	-20	-50	-80	mA	V _{CC} = MAX., V _{OUT} = 0 V
I _{CC}	Power Supply Current		65	94	mA	9310XM • 9316XM
			65	100	mA	9310XC • 9316XC
						V _{CC} = MAX., MR = 0V Other Inputs HIGH

NOTES

- The actual testing procedures used to guarantee the Electrical Characteristics are contained in a detailed Customer Sample Specification. A copy of this specification can be obtained from Fairchild Digital Product Marketing, Mountain View, California.
- Conditions testing, not shown in table, are chosen to guarantee operation under "worst case" conditions.
- The Specified LIMITS represent the "worst case" value for the parameter. Since these "worst case" values normally occur at the temperature and supply voltage extremes, additional noise immunity and guard banding can be achieved by decreasing the allowable system operating ranges.
- Typical limits are at V_{CC} = 5.0 V, 25°C, and maximum loading.
- Not more than one output should be shorted at a time.

SWITCHING CHARACTERISTICS (T_A = 25°C)

SYMBOL	PARAMETER	LIMITS			UNITS	CONDITIONS
		MIN.	TYP.	MAX.		
t _{PLH}	Turn Off Delay CP to Q		12	20	ns	See Fig. 1 V _{CC} = 5.0 V C _L = 15 pF
t _{PHL}	Turn On Delay CP to Q		15	23	ns	
t _{PLH}	Turn Off Delay CP to TC		25	35	ns	
t _{PHL}	Turn On Delay CP to TC		13	22	ns	
t _{PLH}	Turn Off Delay CET to TC		13	19	ns	
t _{PHL}	Turn On Delay CET to TC		13	19	ns	
t _{PHL}	Turn On Delay \overline{MR} to Q		30	45	ns	See Fig. 2
f _{count}	Input Count Frequency	30	45		MHz	See Fig. 1

SWITCHING SET-UP REQUIREMENTS (T_A = 25°C)

SYMBOL	PARAMETER	LIMITS			UNITS	CONDITIONS
		MIN.	TYP.	MAX.		
t _{rec}	Recovery Time for \overline{MR}	15	11		ns	See Fig. 2
t _{pwr} \overline{MR}	Master Reset Pulse Width	30	23		ns	
t _{pwr} CP	Clock Pulse Width	17	11		ns	See Fig. 1
t _s (H) or (L)	Set-up Time Data to Clock	30	20		ns	See Fig. 5
t _h (H) or (L)	Hold Time Data to Clock	0	-19		ns	
t _s (H)	Set-up Time (HIGH) CE to Clock	22	11		ns	See Fig. 6 V _{CC} = 5.0 V
t _h (H)	Hold Time (HIGH) CE to Clock	See Note 6				
t _s (L)	Set-up Time (LOW) CE to Clock	See Note 6				
t _h (L)	Hold Time (LOW) CE to Clock	0	-10		ns	
t _s (H)	Set-up Time (HIGH) \overline{PE} to Clock	See Note 7				
t _h (H)	Hold Time (HIGH) \overline{PE} to Clock	-7	-19		ns	
t _s (L)	Set-up Time (LOW) \overline{PE} to Clock	30	20		ns	
t _h (L)	Hold Time (LOW) \overline{PE} to Clock	See Note 7				

- The Set-up Time "t_s(L)" and Hold Time "t_h(H)" between the Count Enable (CEP and CET) and the Clock (CP) indicate that the HIGH to LOW transition of the CEP and CET must occur only while the Clock is HIGH for conventional operation.
- The Set-Up Time "t_s(H)" and Hold Time "t_h(L)" between the Parallel Enable (PE) and the Clock (CP) indicate that the LOW to HIGH transition of the PE must occur only while the Clock is HIGH for conventional operation.

DEFINITION OF TERMS:

SET-UP TIME (t_s) is defined as the minimum time required for the correct logic level to be present at the logic input prior to the clock transition from LOW to HIGH in order to be recognized and transferred to the outputs.

HOLD TIME (t_h) is defined as the minimum time following the clock transition from LOW to HIGH that the logic level must be maintained at the input in order to insure continued recognition. A negative HOLD TIME indicates that the correct logic level may be released prior to the clock transition from LOW to HIGH and still be recognized.

RECOVERY TIME (t_{rec}) is defined as the minimum time required between the end of the reset pulse and the clock transition from LOW to HIGH in order to recognize and transfer HIGH Data to the Q outputs.

TYPICAL SWITCHING CHARACTERISTICS

PROPAGATION DELAY FROM CLOCK TO ANY OUTPUT VERSUS TEMPERATURE

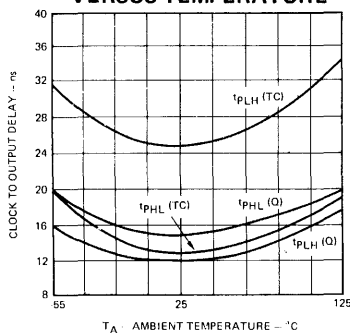

FREQUENCY VERSUS TEMPERATURE

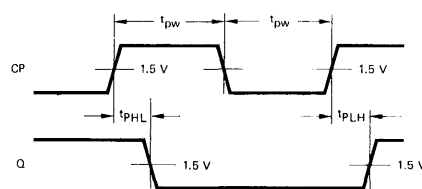
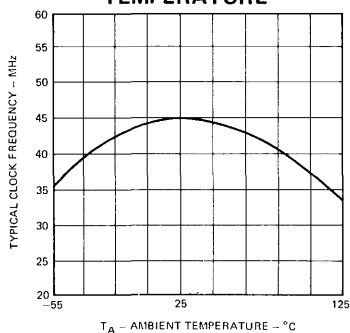

Other Conditions:
PE = MR = H
CEP = CET = H

Fig. 1 CLOCK TO OUTPUT DELAYS, COUNT FREQUENCY AND CLOCK PULSE WIDTH

PROPAGATION DELAY FROM MASTER RESET TO OUTPUT VERSUS TEMPERATURE

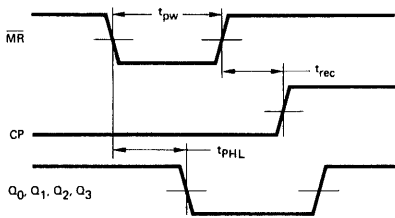
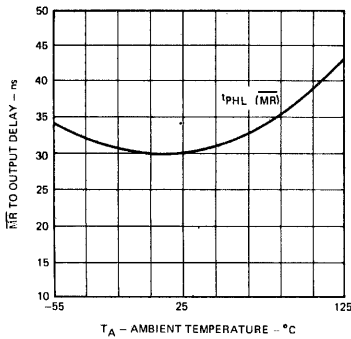

Other Conditions:
 $\overline{PE} = L$
 $P_0 = P_1 = P_2 = P_3 = H$

Fig. 2. MASTER RESET TO OUTPUT DELAY, MASTER RESET PULSE WIDTH, AND MASTER RESET RECOVERY TIME.

PROPAGATION DELAY COUNT ENABLE TERMINAL TO TERMINAL COUNT

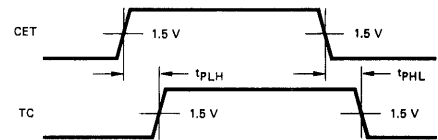
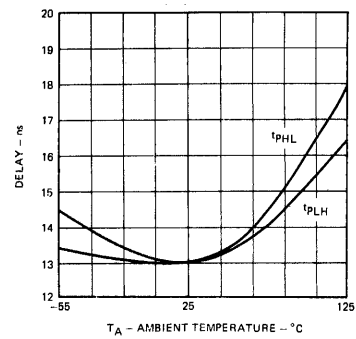

Other Conditions: $CP = \overline{PE} = CEP = \overline{MR} = H$

The positive TC pulse occurs when the outputs are in the ($Q_0 \bullet \overline{Q}_1 \bullet \overline{Q}_2 \bullet Q_3$) state for the 9310 and the ($Q_0 \bullet Q_1 \bullet Q_2 \bullet Q_3$) state for the 9316.

Fig. 3. COUNT ENABLE TRICKLE INPUT TO TERMINAL COUNT OUTPUT DELAYS.

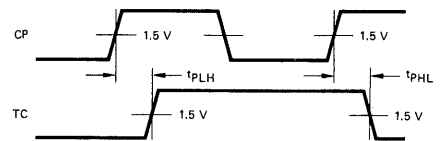

Other Conditions: $\overline{PE} = CEP = CET = \overline{MR} = H$

The positive TC pulse is coincident with the output state ($Q_0 \bullet \overline{Q}_1 \bullet \overline{Q}_2 \bullet Q_3$) for the 9310 and ($Q_0 \bullet Q_1 \bullet Q_2 \bullet Q_3$) for the 9316.

Fig. 4. CLOCK TO TERMINAL COUNT DELAYS.

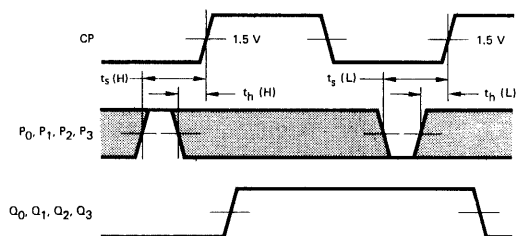

Other Conditions: $\overline{PE} = L, \overline{MR} = H$

The shaded areas indicate when the input is permitted to change for predictable output performance.

Fig. 5. SET-UP TIME (t_s) AND HOLD TIME (t_h) FOR PARALLEL DATA INPUTS.

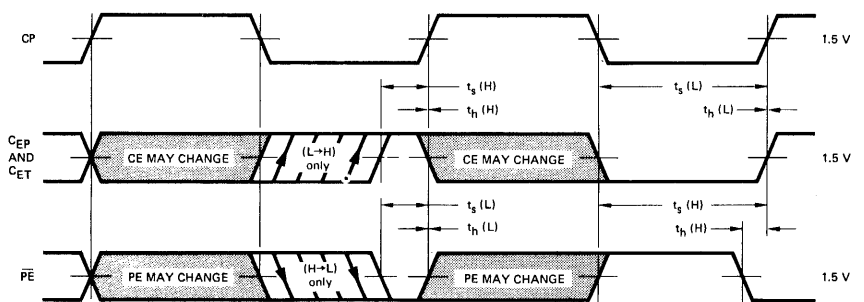
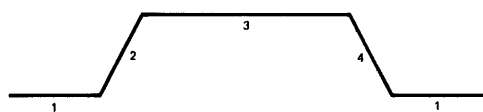

Fig. 6. SET-UP TIME (t_s) AND HOLD TIME (t_h) FOR COUNT ENABLE (CEP) AND (CET) AND PARALLEL ENABLE (\overline{PE}) INPUTS.

Fig. 7. CLOCK PULSE CHARACTERISTICS.



- Region 1: Enter R&S data into master
- Region 2: Inhibit R&S inputs, transfer data from master to slave
- Region 3: Latch master and slave
- Region 4: Isolate slave from master, enable R&S inputs

9310 GENERALIZED FUNCTION TEST

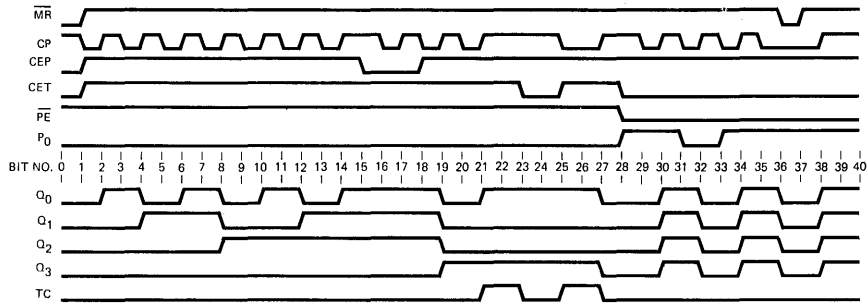

MULTISTAGE COUNTING — The 9310 • 9316 counters may be cascaded to provide multistage synchronous counting. Two methods commonly used to cascade these counters are shown in Figures 8 and 9.

In multistage counting, all less significant stages must be at their terminal count before the next more significant counter is enabled. The 9310 • 9316 internally decodes the terminal count condition and "ANDs" it with the CET input to generate the terminal count (TC) output. This arrangement allows one to perform series enabling by connecting the TC output (enable signal) to the CET input of the following stage, Figure 8. The setup requires very few interconnections, but has the following drawback: since it takes time for the enable to ripple through the counter stages, there is a reduction in maximum counting speed. To increase the counting rate, it is necessary to decrease the propagation delay of the TC signal, which is done in the second method.

The scheme illustrated in Figure 9 permits multistage counting up to 11 stages limited by the fan out of the terminal count. For an alternate scheme for more stages see Application Note 184.

The CEP input of the 9310 • 9316 is internally "ANDed" with the CET input and as a result, both must be HIGH for the counter to be enabled. The CET inputs are connected as before except for the second stage. There the CET input is left floating and is therefore HIGH. Also, all CEP inputs are connected to the terminal output of the first stage. The advantage of this method is best seen by assuming all stages except the second and last are in their terminal condition. As the second stage advances to its terminal count, an enable is allowed to trickle down to the last counter stage, but has the full cycle time of the first counter to reach it. Then as the TC of the first stage goes active (HIGH), all CEP inputs are activated, allowing all stages to count on the next clock.

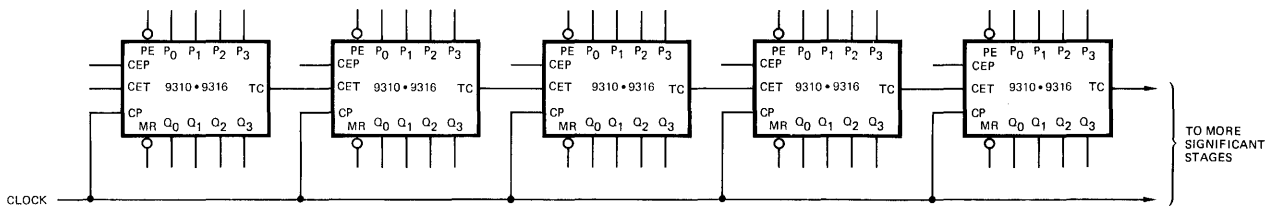

Fig. 8. SYNCHRONOUS MULTISTAGE COUNTING SCHEME (SLOW)

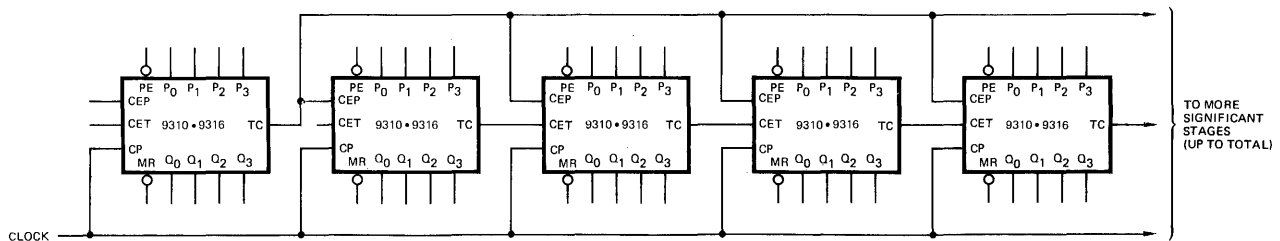

Fig. 9. SYNCHRONOUS MULTISTAGE COUNTING SCHEME (FAST)

LPTTL/MSI 93L10•93L16

LOW POWER BCD DECADE COUNTER/4-BIT BINARY COUNTER

DESCRIPTION — The 93L10 is a High Speed Synchronous BCD Decade Counter and the 93L16 is a High Speed Synchronous 4-Bit Binary Counter. They are synchronously presettable, multifunctional MSI building blocks useful in a large number of counting, digital integration and conversion applications. Several stages of synchronous operation are obtainable with no external gating packages required through an internal carry lookahead counting technique.

- SYNCHRONOUS COUNTING AND PARALLEL ENTRY
- DECODED TERMINAL COUNT
- BUILT-IN CARRY CIRCUITRY
- TYPICAL COUNTING FREQUENCY OF 20 MHz
- TYPICAL POWER DISSIPATION OF 85 mW
- THE INPUT/OUTPUT CHARACTERISTICS PROVIDE EASY INTERFACING WITH FAIRCHILD DTL, LPDTL, AND TTL FAMILIES
- INPUT DIODE CLAMPING
- TTL COMPATIBLE

PIN NAMES

\overline{PE}	Parallel Enable (Active LOW) Input
P_0, P_1, P_2, P_3	Parallel Inputs
CEP	Count Enable Parallel Input
CET	Count Enable Trickle Input
CP	Clock (Active HIGH Going Edge) Input
\overline{MR}	Master Reset (Active LOW) Input
Q_0, Q_1, Q_2, Q_3	Parallel Outputs
TC	Terminal Count Outputs

LOADING

	HIGH	LOW
\overline{PE}	1.0 U.L.	0.5 U.L.
P_0, P_1, P_2, P_3	0.33 U.L.	0.17 U.L.
CEP	0.5 U.L.	0.25 U.L.
CET	1.0 U.L.	0.5 U.L.
CP	1.0 U.L.	0.5 U.L.
\overline{MR}	0.5 U.L.	0.25 U.L.
Q_0, Q_1, Q_2, Q_3	8.0 U.L.	2.0 U.L.
TC	8.0 U.L.	2.0 U.L.

1 Unit Load (U.L.) = 40 μ A HIGH/1.6 mA LOW

STATE DIAGRAM

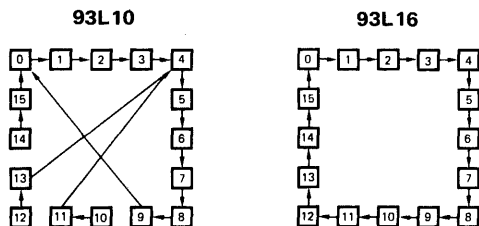

LOGIC EQUATIONS

Count Enable = CEP • CET • PE
 TC for 93L10 = CET • Q_0 • $\overline{Q_1}$ • $\overline{Q_2}$ • Q_3
 TC for 93L16 = CET • Q_0 • Q_1 • Q_2 • Q_3
 Preset = \overline{PE} • CP+ (rising clock edge)
 Reset = \overline{MR}

NOTE:

The 93L10 can be preset to any state, but will not count beyond 9. If preset to state 10, 11, 12, 13, 14, or 15, it will return to its normal sequence within two clock pulses.

LOGIC SYMBOL

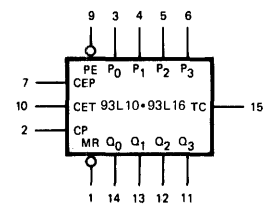

V_{CC} = Pin 16
 GND = Pin 8

CONNECTION DIAGRAMS DIP (TOP VIEW)

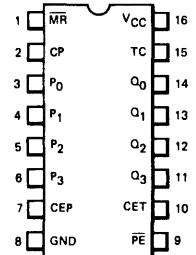

FLATPAK (TOP VIEW)

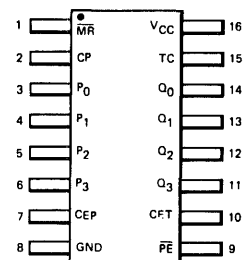

FUNCTIONAL DESCRIPTION — The 93L10 is a high speed BCD Decade Counter, and the 93L16 is a high speed Binary Counter. Both counters are fully synchronous with the clock pulse driving four master/slave flip-flops in parallel through a clock buffer. During the LOW to HIGH transition of the clock, the master is inhibited from further change. After the masters are locked out, data is transferred from the master to the slaves and reflected at the outputs. When the clock is HIGH, the masters are inhibited and the master/slave data path remains established. During the HIGH to LOW transition of the clock, the slave is inhibited from further change, followed by the enabling of the masters for the acceptance of data from the counting logic or the parallel entry logic. (See Clock Pulse Characteristics Figure 7.)

The three control inputs, Parallel Enable (\overline{PE}), Count Enable Parallel (CEP), and Count Enable Trickle (CET), select the mode of operation as shown in the tables below. When the conditions for counting are satisfied, the rising edge of a clock pulse will change the counters to the next state of the count sequence shown in the State Diagram on the previous page. The Count Mode is enabled when CEP and CET inputs and \overline{PE} are HIGH.

The 93L10 and 93L16 can be synchronously preset from the four Parallel inputs, (P_{0-3}) when \overline{PE} is LOW. When the Parallel Enable and Clock are LOW, each master of the flip-flops is connected to the appropriate parallel input (P_{0-3}) and the slaves (outputs) are steady in their previous state. When the clock goes HIGH, the masters are inhibited and this information is transferred to the slaves and reflected at the outputs. The parallel enable input overrides both count enable inputs, presetting the counter when LOW.

Terminal count is HIGH when the counter is at terminal count (state 9 for 93L10, and state 15 for 93L16), and Count Enable Trickle is HIGH, as is shown in the logic equations. Without additional logic, multistage synchronous counting at high speeds is made possible with a high speed lookahead technique utilizing the count enable and terminal count logic. A multistage counter illustrating these techniques is shown and discussed in the application section.

When LOW, the asynchronous master reset overrides all other inputs resetting the four outputs LOW.

Conventional operation of the 93L10-93L16, as shown in the Mode Selection table, requires that the mode control inputs (\overline{PE} , CEP, CET) are stable while the clock is LOW. This is no constraint for a normal synchronous system where all signals are generated by the rising edge of the clock.

For some applications, the designer may want to change those inputs while the clock is LOW. In this case the 93L10-93L16 will behave in a predictable manner. For example:

If \overline{PE} goes HIGH while the clock is LOW, but Count Enable is not active during the remaining clock LOW period (i.e. CEP or CET are LOW), the subsequent LOW to HIGH clock transition will change $Q_0 \dots Q_3$ to the $P_0 \dots P_3$ data that existed at the set-up time before the rising edge of \overline{PE} .

If Count Enable is active (i.e. CEP and CET are HIGH) during some portion of the clock LOW period, but \overline{PE} is HIGH (inactive) during the entire clock LOW period, the subsequent LOW to HIGH clock transition will change $Q_0 \dots Q_3$ to the next count value.

If \overline{PE} goes HIGH while the clock is LOW, but Count Enable is active (CEP and CET are HIGH) during some portion of the remaining clock LOW period, the 93L10-93L16 will perform a mixture of counting and loading. On the LOW to HIGH clock transition, outputs $Q_0 \dots Q_3$ will change as the count sequence or the loading requires. Only the outputs that would not change in the count sequence and are also reloaded with their present value stay constant.

LOGIC DIAGRAMS

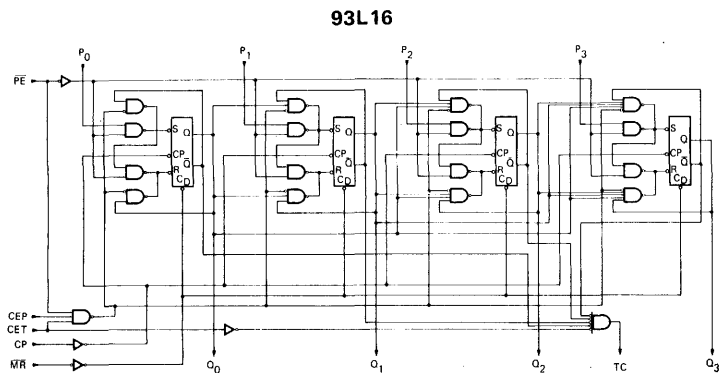
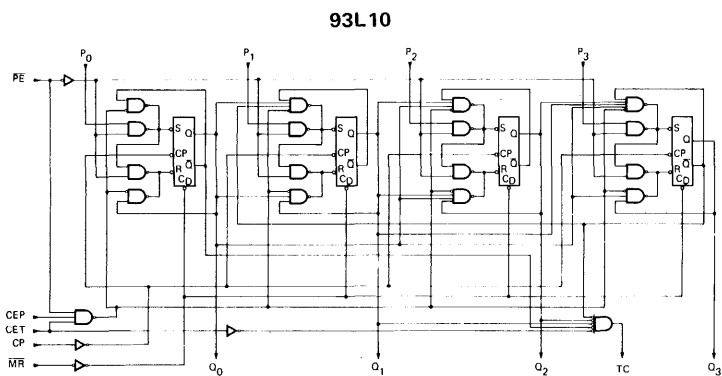

**93L10 AND 93L16
MODE SELECTION**

\overline{PE}	CEP	CET	MODE
L	L	L	Preset
L	L	H	Preset
L	H	L	Preset
L	H	H	Preset
H	L	L	No Change
H	L	H	No Change
H	H	L	No Change
H	H	H	Count

(\overline{MR} = HIGH)

TERMINAL COUNT GENERATION

CET	93L10 ($Q_0 \bullet \overline{Q_1} \bullet \overline{Q_2} \bullet Q_3$)	93L16 ($Q_0 \bullet Q_1 \bullet Q_2 \bullet Q_3$)	TC
L	L	L	L
L	H	H	L
H	L	L	L
H	H	H	H

$TC = CET \bullet Q_0 \bullet \overline{Q_1} \bullet \overline{Q_2} \bullet Q_3$ (93L10)

$TC = CET \bullet Q_0 \bullet Q_1 \bullet Q_2 \bullet Q_3$ (93L16)

POSITIVE LOGIC = H = HIGH Voltage Level
L = LOW Voltage Level

ABSOLUTE MAXIMUM RATINGS (above which the useful life may be impaired)

Storage Temperature	-65°C to +150°C
Temperature (Ambient) Under Bias	-55°C to +125°C
V _{CC} Pin Potential to Ground Pin	-0.5 V to +7.0 V
*Input Voltage (dc)	-0.5 V to +5.5 V
*Input Current (dc)	-30 mA to +5.0 mA
Voltage Applied to Outputs (Output HIGH)	-0.5 V to +V _{CC} value
Output Current (dc) (Output LOW)	+30 mA

*Either Input Voltage limit or Input Current limit is sufficient to protect the inputs.

GUARANTEED OPERATING RANGES

PART NUMBER	SUPPLY VOLTAGE (V _{CC})			TEMPERATURE
	MIN.	TYP.	MAX.	
93L10XM-93L16XM	4.5 V	5.0 V	5.5 V	-55°C to 125°C
93L10XC-93L16XC	4.75 V	5.0 V	5.25 V	0°C to 75°C

X = package type; F for Flatpak, D for Ceramic Dip, P for Plastic Dip. See Packaging Information Section for packages available on this product.

ELECTRICAL CHARACTERISTICS OVER OPERATING TEMPERATURE RANGE (Unless Otherwise Noted)

SYMBOL	PARAMETER	LIMITS			UNITS	CONDITIONS
		MIN.	TYP. (Note 4)	MAX.		
V _{OH}	Output HIGH Voltage	2.4	3.6		Volts	V _{CC} = MIN., I _{OH} = -0.32 mA V _{IN} = V _{IH} or V _{IL}
V _{OL}	Output LOW Voltage		0.15	0.3	Volts	V _{CC} = MIN., I _{OL} = 3.2 mA V _{IN} = V _{IH} or V _{IL}
V _{IH}	Input HIGH Voltage	2.0			Volts	Guaranteed Input HIGH Threshold Voltage for All Inputs
V _{IL}	Input LOW Voltage			0.7	Volts	Guaranteed Input LOW Threshold Voltage for All Inputs
I _{IL}	Input LOW Current MR, CEP CP, PE, CET P ₀ , P ₁ , P ₂ & P ₃		-0.25 -0.50 -0.13	-0.40 -0.80 -0.27	mA	V _{CC} = MAX., V _{IN} = 0.3 V
I _{IH}	Input HIGH Current MR, CEP CP, PE, CET P ₀ , P ₁ , P ₂ & P ₃		2.0 4.0 1.0	20 40 13.3	μA	V _{CC} = MAX., V _{IN} = 2.4 V
I _{SC} (Note 5)	Output Short Circuit Current	-2.5	-16	-25	mA	V _{CC} = MAX., V _{OUT} = 0.0 V
I _{CC}	Power Supply Current		17	27.5	mA	V _{CC} = MAX.

NOTES:

- The actual testing procedures used to guarantee the Electrical Characteristics are contained in a detailed Customer Sample Specification. A copy of this specification can be obtained from Fairchild Digital Product Marketing, Mountain View, California.
- Conditions for testing, not shown in the table, are chosen to guarantee operation under "worst case" conditions.
- The specified LIMITS represent the "worst case" value for the parameter. Since these "worst case" values normally occur at the temperature and supply voltage extremes, additional noise immunity and guard banding can be achieved by decreasing the allowable system operating ranges.
- Typical limits are at V_{CC} = 5.0 V, 25°C, and maximum loading.
- Not more than one output should be shorted at a time.

COUNTING APPLICATIONS

For typical counting applications, see Multistage Counter and Synchronous Multistage Counting Scheme in 9310-9316 data sheet in TTL/MSI section of this catalog.

SWITCHING CHARACTERISTICS (T_A = 25°C)

SYMBOL	PARAMETER	LIMITS			UNITS	CONDITIONS	
		MIN.	TYP.	MAX.			
t _{PLH}	Turn Off Delay CP to Q		20	32	ns	See Fig. 1	V _{CC} = 5.0 V C _L = 15 pF
t _{PHL}	Turn On Delay CP to Q		26	39	ns		
t _{PLH}	Turn Off Delay CP to TC		44	66	ns	See Fig. 4	
t _{PHL}	Turn On Delay CP to TC		20	30	ns		
t _{PLH}	Turn Off Delay CET to TC		20	30	ns	See Fig. 3	
t _{PHL}	Turn On Delay CET to TC		20	30	ns		
t _{PHL}	Turn On Delay MR to Q		40	72	ns	See Fig. 2	
f _{count}	Input Count Frequency	13	23		MHz	See Fig. 1	

SWITCHING SET-UP REQUIREMENTS (T_A = 25°C)

SYMBOL	PARAMETER	LIMITS			UNITS	CONDITIONS	
		MIN.	TYP.	MAX.			
t _{rec}	Recovery Time for MR	30	20		ns	See Fig. 2	V _{CC} = 5.0 V
t _{pwMR}	Master Reset Pulse Width	35	20		ns		
t _{pwCP}	Clock Pulse Width	25	15		ns	See Fig. 1	
t _s (H) or (L)	Set-up Time Data to Clock	75	50		ns	See Fig. 5	
t _h (H) or (L)	Hold Time Data to Clock	0	-20		ns		
t _s (H)	Set-up Time (HIGH) CE to Clock	26	17		ns	See Fig. 6	
t _h (H)	Hold Time (HIGH) CE to Clock	See Note 6					
t _s (L)	Set-up Time (LOW) CE to Clock	See Note 6					
t _h (L)	Hold Time (LOW) CE to Clock	0	-17		ns		
t _s (H)	Set-up Time (HIGH) PE to Clock	See Note 7					
t _h (H)	Hold Time (HIGH) PE to Clock	0	-35		ns		
t _s (L)	Set-up Time (LOW) PE to Clock	53	35		ns		
t _h (L)	Hold Time (LOW) PE to Clock	See Note 7					

NOTES:

- The Set-up Time "t_s(L)" and Hold Time "t_h(H)" between the Count Enable (CEP and CET) and the Clock (CP) indicate that the HIGH to LOW transition of the CEP and CET must occur only while the Clock is HIGH for conventional operation.
- The Set-up Time "t_s(H)" and Hold Time "t_h(L)" between the Parallel Enable (PE) and the Clock (CP) indicate that the LOW to HIGH transition of the PE must occur only while the clock is HIGH for conventional operation.

DEFINITION OF TERMS:

SET-UP TIME (t_s) is defined as the minimum time required for the correct logic level to be present at the logic input prior to the clock transition from LOW to HIGH in order to be recognized and transferred to the outputs.

HOLD TIME (t_h) is defined as the minimum time following the clock transition from LOW to HIGH that the logic level must be maintained at the input in order to insure continued recognition. A negative HOLD TIME indicates that the correct logic level may be released prior to the clock transition from LOW to HIGH and still be recognized.

RECOVERY TIME (t_{rec}) is defined as the minimum time required between the end of the reset pulse and the clock transition from LOW to HIGH in order to recognize and transfer HIGH Data to the Q outputs.

SWITCHING CHARACTERISTICS

CLOCK TO OUTPUT DELAYS, COUNT FREQUENCY, AND CLOCK PULSE WIDTH.

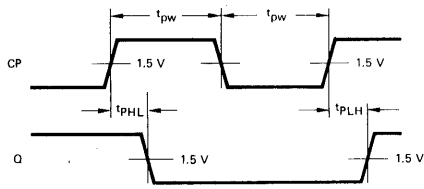

Other Conditions:
 $\overline{PE} = \overline{MR} = H$
 $CET = CET = H$

Fig. 1

MASTER RESET TO OUTPUT DELAY, MASTER RESET PULSE WIDTH, AND MASTER RESET RECOVERY TIME.

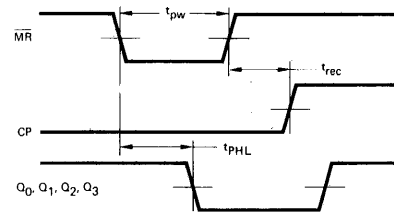

Other Conditions:
 $\overline{PE} = L$
 $P_0 = P_1 = P_2 = P_3 = H$

Fig. 2

SWITCHING CHARACTERISTICS (cont'd)

COUNT ENABLE TRICKLE INPUT TO TERMINAL COUNT OUTPUT DELAYS.

The positive TC pulse occurs when the outputs are in the ($Q_0 \bullet \bar{Q}_1 \bullet \bar{Q}_2 \bullet Q_3$) state for the 93L10 and the ($Q_0 \bullet Q_1 \bullet Q_2 \bullet Q_3$) state for the 93L16.

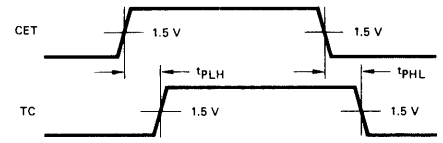

Other Conditions: $CP = \bar{PE} = CEP = \bar{MR} = H$

Fig. 3

CLOCK TO TERMINAL COUNT DELAYS.

The positive TC pulse is coincident with the output state ($Q_0 \bullet \bar{Q}_1 \bullet \bar{Q}_2 \bullet Q_3$) for the 93L10 and ($Q_0 \bullet Q_1 \bullet Q_2 \bullet Q_3$) for the 93L16.

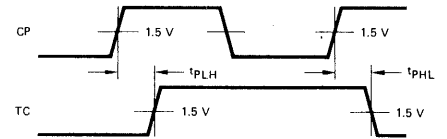

Other Conditions: $\bar{PE} = CEP = CET = \bar{MR} = H$

Fig. 4

SET-UP TIME (t_s) AND HOLD TIME (t_h) FOR PARALLEL DATA INPUTS.

The shaded areas indicate when the input is permitted to change for predictable output performance.

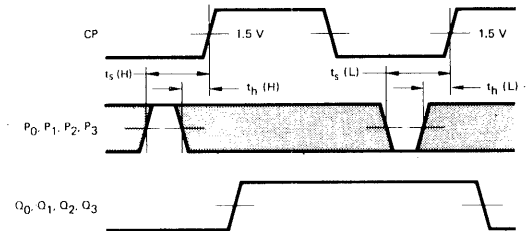

Other Conditions: $\bar{PE} = L, \bar{MR} = H$

Fig. 5

SET-UP TIME (t_s) AND HOLD TIME (t_h) FOR COUNT ENABLE (CEP) AND (CET) AND PARALLEL ENABLE (\bar{PE}) INPUTS.

The shaded areas indicate when the input is permitted to change for predictable output performance.

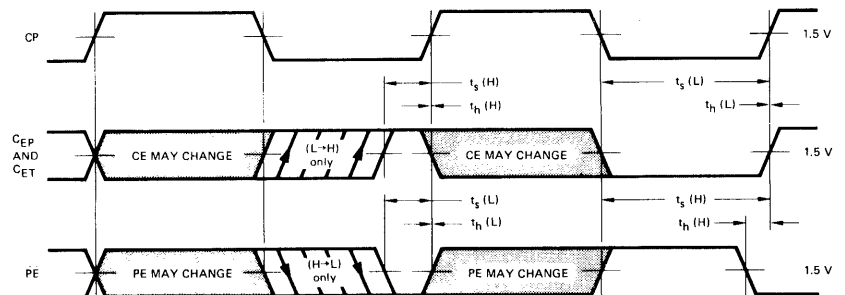

Fig. 6

CLOCK PULSE CHARACTERISTICS.

- Region 1: Enter R&S data into master
- Region 2: Inhibit R&S inputs, transfer data from master to slave
- Region 3: Latch master and slave
- Region 4: Isolate slave from master, enable R&S inputs

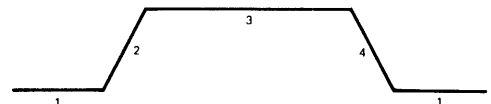

Fig. 7

TTL/MSI 93S10 • 93S16

BCD DECADE COUNTER/4-BIT BINARY COUNTER

TO BE ANNOUNCED

DESCRIPTION — The 93S10 is a super high speed synchronous BCD Decade Counter and the 93S16 is a super high speed synchronous 4-Bit Binary Counter. They are synchronously presettable, multifunctional MSI building blocks useful in a large number of counting, digital integration and conversion applications. Several stages of synchronous operation are obtainable with no external gating packages required through an internal carry lookahead counting technique. Each device utilizes Schottky TTL processing to achieve the ultra high speeds.

- TYPICAL COUNTING FREQUENCY OF 100 MHz
- SYNCHRONOUS COUNTING AND PARALLEL ENTRY
- DECODED TERMINAL COUNT
- BUILT-IN CARRY CIRCUITRY
- THE INPUT/OUTPUT CHARACTERISTICS PROVIDE EASY INTERFACING WITH FAIRCHILD DTL, LPDTL, AND TTL FAMILIES
- INPUT DIODE CLAMPING

PIN NAMES

\overline{PE}	Parallel Enable (Active LOW) Input
P_0, P_1, P_2, P_3	Parallel Inputs
CEP	Count Enable Parallel Input
CET	Count Enable Trickle Input
CP	Clock (Active HIGH) Going Edge Input
\overline{MR}	Master Reset (Active LOW) Input
Q_0, Q_1, Q_2, Q_3	Parallel Outputs
TC	Terminal Count Outputs

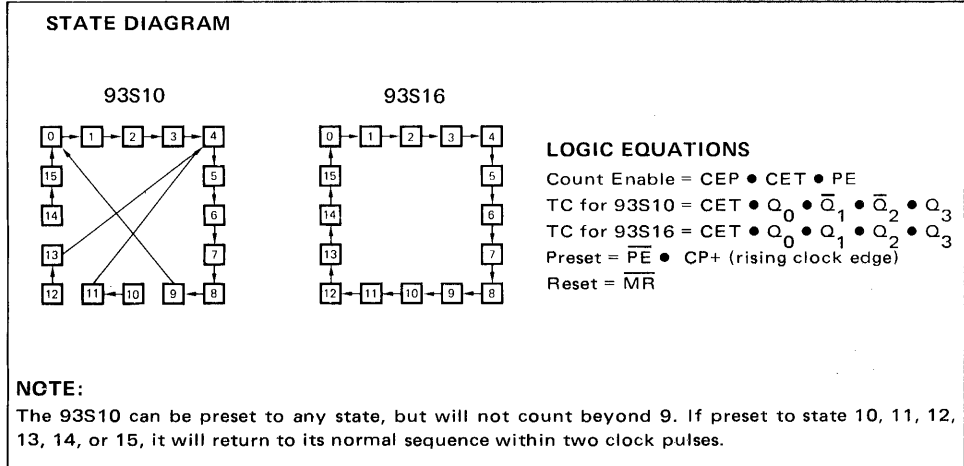
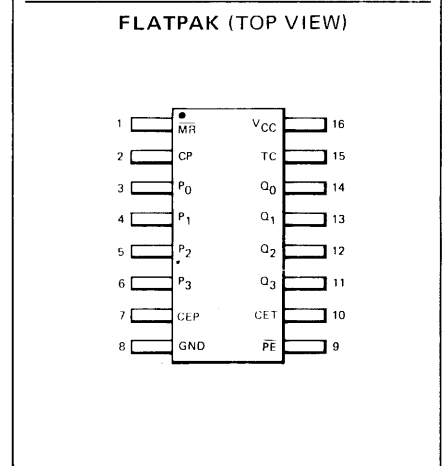
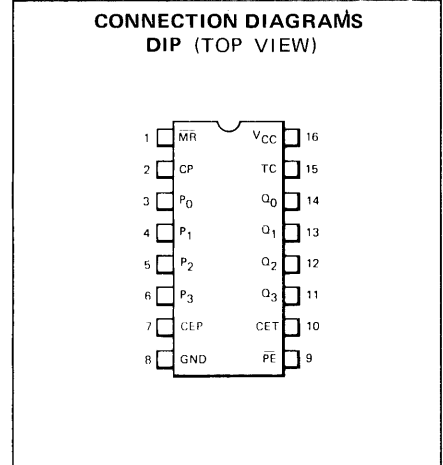
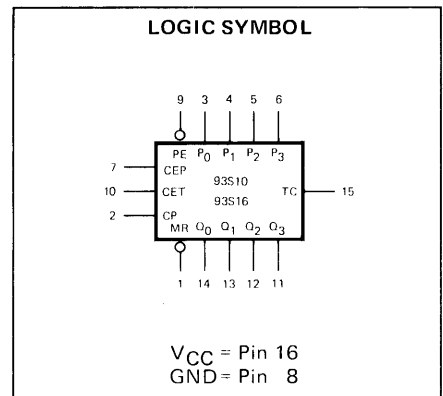

TTL/MSI 9311

ONE-OF-SIXTEEN DECODER/DEMULTIPLEXER

DESCRIPTION — The 9311 is a TTL/MSI Multi-Purpose Decoder designed to accept four inputs and provide 16 mutually exclusive outputs. The circuit uses TTL for high speed and high fan out capability, and is compatible with all members of the Fairchild TTL family.

- MUTUALLY EXCLUSIVE OUTPUTS
- HIGH CAPACITIVE DRIVE CAPABILITY
- DEMULTIPLEXING CAPABILITY
- TYPICAL POWER DISSIPATION OF 175 mW
- INPUT CLAMP DIODES
- 2-INPUT ENABLE GATE
- TTL COMPATIBLE

PIN NAMES

A_0, A_1, A_2, A_3	Address Inputs
\bar{E}_0, \bar{E}_1	AND Enable (Active LOW) Inputs
$\bar{0}$ to $\bar{15}$	(Active LOW) Outputs (Note b)

LOADING (Note a)

1 U.L.
1 U.L.
10 U.L.

NOTES:

- a. 1 Unit Load (U.L.) = 40 μ A HIGH/1.6 mA LOW
- b. 10 U.L. is the output LOW drive factor and 20 U.L. is the output HIGH drive factor.

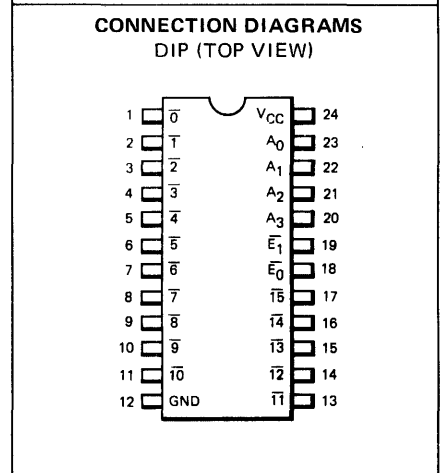
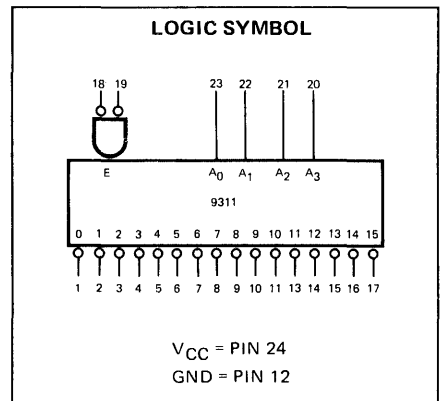
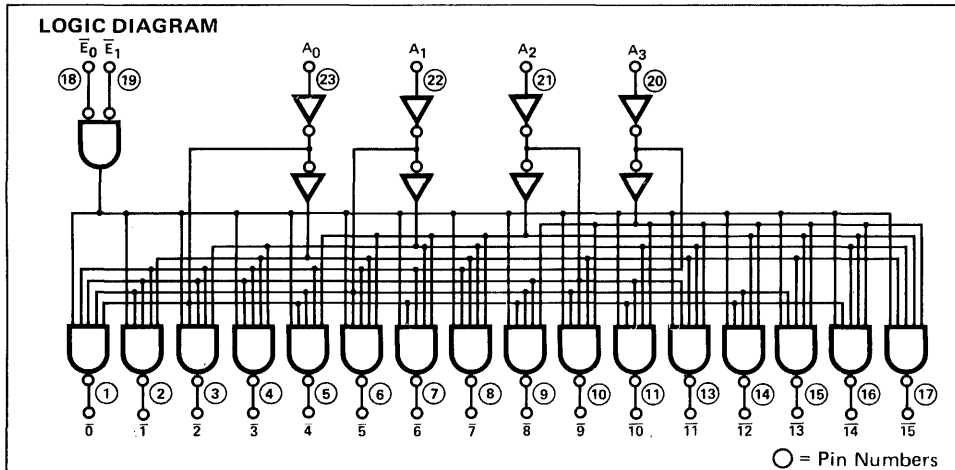

FAIRCHILD TTL/MSI • 9311

ABSOLUTE MAXIMUM RATINGS (above which the useful life may be impaired)

Storage Temperature	-65°C to +150°C
Temperature (Ambient) Under Bias	-55°C to +125°C
V _{CC} Pin Potential to Ground Pin	-0.5 V to +7.0 V
*Input Voltage (dc)	-0.5 V to +5.5 V
*Input Current (dc)	-30 mA to +5.0 mA
Voltage Applied to Outputs (Output HIGH)	-0.5 V to +V _{CC} value
Output Current (dc) (Output LOW)	+30 mA

*Either Input Voltage limit or Input Current limit is sufficient to protect the inputs.

GUARANTEED OPERATING RANGES

PART NUMBER	SUPPLY VOLTAGE (V _{CC})			TEMPERATURE
	MIN.	TYP.	MAX.	
9311XM	4.5 V	5.0 V	5.5 V	-55°C to 125°C
9311XC	4.75 V	5.0 V	5.25 V	0°C to 75°C

X=package type; F for Flatpak, D for Ceramic Dip, P for Plastic Dip. See packaging Information Section for packages available on this product.

ELECTRICAL CHARACTERISTICS OVER OPERATING TEMPERATURE RANGE (unless otherwise noted)

SYMBOL	PARAMETER	LIMITS			UNITS	CONDITIONS
		MIN.	TYP. (Note 4)	MAX.		
V _{IH}	Input HIGH Voltage	2.0			Volts	Guaranteed Input HIGH Threshold Voltage for All Inputs
V _{IL}	Input LOW Voltage			0.8	Volts	Guaranteed Input LOW Threshold Voltage for All Inputs
V _{CD}	Input Clamp Diode Voltage			-1.5	Volts	V _{CC} = MIN., I _{IN} = -12mA, T _A = 25°C
V _{OH}	Output HIGH Voltage	2.4	3.6		Volts	V _{CC} = MIN., I _{OH} = -800 μA V _{IN} = V _{IH} or V _{IL} per Truth Table
V _{OL}	Output LOW Voltage		0.2	0.4	Volts	V _{CC} = MIN., I _{OL} = 16 mA V _{IN} = V _{IH} or V _{IL} per Truth Table
I _{IH}	Input HIGH Current		10	40	μA	V _{CC} = MAX., V _{IN} = 2.4 V
I _{IL}					1.0	mA
I _{IL}	Input LOW Current		-0.96	-1.6	mA	V _{CC} = MAX., V _{IN} = 0.4 V
I _{SC} (I _{OS})	Output Short Circuit Current (Note 5)	-20	-40	-70	mA	V _{CC} = MAX., V _{OUT} = 0 V
I _{CC}	Power Supply Current		35	62	mA	V _{CC} = MAX.

NOTES:

- The actual testing procedures used to guarantee the Electrical Characteristics are contained in a detailed Customer Sample Specification. A copy of this specification can be obtained from Fairchild Digital Product Marketing, Mountain View, California.
- Conditions for testing, not shown in the table, are chosen to guarantee operation under "worst case" conditions.
- The specified LIMITS represent the "worst case" value for the parameter. Since these "worst case" values normally occur at the temperature and supply voltage extremes, additional noise immunity and guard banding can be achieved by decreasing the allowable system operating ranges.
- Typical limits are at V_{CC} = 5.0 V, 25°C, and maximum loading.
- Not more than one output should be shorted at a time.

SWITCHING CHARACTERISTICS (T_A = 25°C)

SYMBOL	PARAMETER	9311XM			9311XC			UNITS	CONDITIONS
		MIN.	TYP.	MAX.	MIN.	TYP.	MAX.		
t _{PLH}	Turn Off Delay A Input to Output		19	28		19	31	ns	V _{CC} = 5.0 V C _L = 15 pF Pin 12 = GND (See Fig. 1)
t _{PHL}	Turn On Delay A Input to Output		19	25		19	28		
t _{PLH}	Turn Off Delay \bar{E} Input to Output		12	20		12	23	ns	
t _{PHL}	Turn On Delay \bar{E} Input to Output		14	21		14	24		

LPTTL/MSI 93L11

LOW POWER ONE-OF-SIXTEEN DECODER

DESCRIPTION – The LPTTL/MSI 93L11 is a Multi-Purpose Decoder designed to accept four inputs and provide 16 mutually exclusive outputs. The circuit uses TTL technology and is compatible with the Fairchild TTL family.

- MULTI-FUNCTION CAPABILITY
- MUTUALLY EXCLUSIVE OUTPUTS
- HIGH CAPACITIVE DRIVE CAPABILITY
- DEMULTIPLEXING CAPABILITY
- TWO INPUT ENABLE GATE
- TYPICAL PROPAGATION DELAY OF 70 ns
- TYPICAL POWER DISSIPATION OF 58 mW
- INPUT CLAMP DIODES LIMIT HIGH SPEED TERMINATION EFFECTS
- ALL CERAMIC "HERMETIC" 24-LEAD DUAL IN-LINE AND FLAT PACKAGES
- TTL COMPATIBLE

PIN NAMES

A_0, A_1, A_2, A_3 Address Inputs
 \bar{E}_0, \bar{E}_1 AND Enable (Active LOW) Inputs
 0 to 15 (Active LOW) Outputs

LOADING	
HIGH	LOW
0.5 U.L.	0.25 U.L.
0.5 U.L.	0.25 U.L.
10 U.L.	2.5 U.L.

1 Unit Load (U.L.) = 40 μ A HIGH/1.6 mA LOW

LOGIC SYMBOL

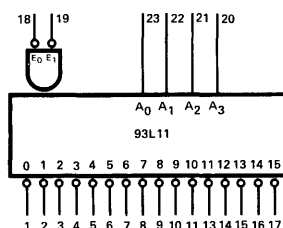

V_{CC} = Pin 24
 GND = Pin 12

CONNECTION DIAGRAMS

DIP (TOP VIEW)

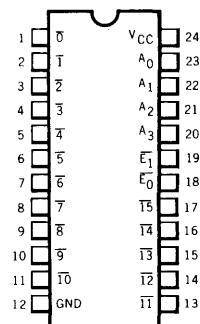

FLATPAK (TOP VIEW)

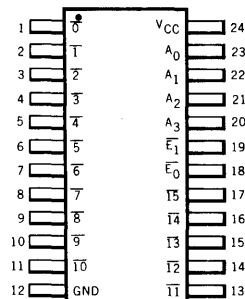

LOGIC DIAGRAM

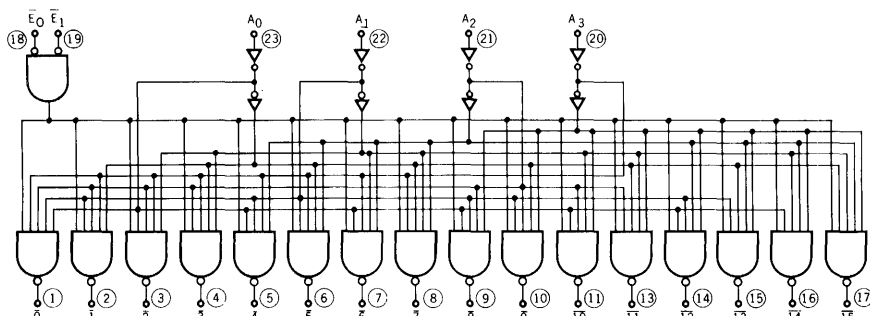

○ = Pin Numbers

FAIRCHILD LPTTL/MSI • 93L11

FUNCTIONAL DESCRIPTION – The 93L11 decoder accepts four active HIGH binary inputs and provides 16 mutually exclusive active LOW outputs, as shown by logic symbol. The active LOW outputs facilitate addressing other MSI units with active LOW enables.

The 93L11 can demultiplex data by routing it from one input to one of sixteen possible decoder outputs. The desired output is addressed and the data is applied to one of the enable inputs. When the other enable is LOW, the addressed output will follow the state of the applied data.

TRUTH TABLE

\bar{E}_0	\bar{E}_1	A ₀	A ₁	A ₂	A ₃	0	1	2	3	4	5	6	7	8	9	10	11	12	13	14	15	
H	H	X	X	X	X	H	H	H	H	H	H	H	H	H	H	H	H	H	H	H	H	H
H	L	X	X	X	X	H	H	H	H	H	H	H	H	H	H	H	H	H	H	H	H	H
L	H	X	X	X	X	H	H	H	H	H	H	H	H	H	H	H	H	H	H	H	H	H
L	L	L	L	L	L	L	H	H	H	H	H	H	H	H	H	H	H	H	H	H	H	H
L	L	H	L	L	L	H	L	H	H	H	H	H	H	H	H	H	H	H	H	H	H	H
L	L	L	H	L	L	H	H	L	H	H	H	H	H	H	H	H	H	H	H	H	H	H
L	L	H	H	L	L	H	H	H	L	H	H	H	H	H	H	H	H	H	H	H	H	H
L	L	L	L	H	L	H	H	H	H	L	H	H	H	H	H	H	H	H	H	H	H	H
L	L	L	H	H	L	H	H	H	H	H	L	H	H	H	H	H	H	H	H	H	H	H
L	L	L	L	L	H	H	H	H	H	H	H	L	H	H	H	H	H	H	H	H	H	H
L	L	L	H	L	H	H	H	H	H	H	H	H	L	H	H	H	H	H	H	H	H	H
L	L	H	H	L	H	H	H	H	H	H	H	H	H	L	H	H	H	H	H	H	H	H
L	L	L	L	H	H	H	H	H	H	H	H	H	H	H	L	H	H	H	H	H	H	H
L	L	H	L	H	H	H	H	H	H	H	H	H	H	H	H	L	H	H	H	H	H	H
L	L	L	H	H	H	H	H	H	H	H	H	H	H	H	H	H	L	H	H	H	H	H
L	L	L	L	H	H	H	H	H	H	H	H	H	H	H	H	H	H	L	H	H	H	H
L	L	H	H	H	H	H	H	H	H	H	H	H	H	H	H	H	H	H	L	H	H	H
L	L	H	H	H	H	H	H	H	H	H	H	H	H	H	H	H	H	H	H	L	H	H
L	L	H	H	H	H	H	H	H	H	H	H	H	H	H	H	H	H	H	H	H	L	H
L	L	H	H	H	H	H	H	H	H	H	H	H	H	H	H	H	H	H	H	H	H	L

H = HIGH Voltage Level
 L = LOW Voltage Level
 X = Level Does Not Affect Output

TYPICAL INPUT AND OUTPUT CIRCUITS

INPUTS
EQUIVALENT CIRCUIT

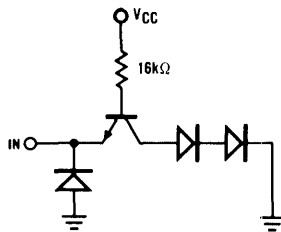

OUTPUTS
EQUIVALENT CIRCUIT

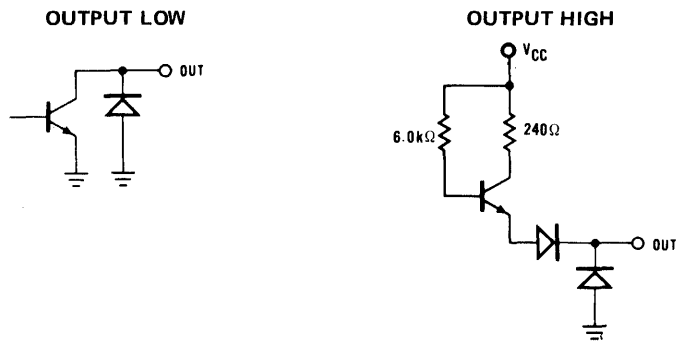

ABSOLUTE MAXIMUM RATINGS (above which the useful life may be impaired)

Storage Temperature	–65°C to +150°C
Temperature (Ambient) Under Bias	–55°C to +125°C
V _{CC} Pin Potential to Ground Pin	–0.5 V to +7.0 V
*Input Voltage (dc)	–0.5 V to +5.5 V
*Input Current (dc)	–30 mA to +5.0 mA
Voltage Applied to Outputs (Output HIGH)	–0.5 V to +V _{CC} value
Output Current (dc) (Output LOW)	+30 mA

*Either Input Voltage limit or Input Current limit is sufficient to protect the inputs.

FAIRCHILD LPTTL/MSI • 93L11

GUARANTEED OPERATING RANGES

PART NUMBER	SUPPLY VOLTAGE (V_{CC})			TEMPERATURE
	MIN.	TYP.	MAX.	
93L11XM	4.5 V	5.0 V	5.5 V	-55°C to 125°C
93L11XC	4.75 V	5.0 V	5.25 V	0°C to 75°C

X = package type; F for Flatpak, D for Ceramic Dip, P for Plastic Dip. See Packaging Information Section for packages available on this product.

ELECTRICAL CHARACTERISTICS OVER OPERATING TEMPERATURE RANGE (Unless Otherwise Noted)

SYMBOL	PARAMETER	LIMITS			UNITS	CONDITIONS
		MIN.	TYP. (Note 4)	MAX.		
V_{OH}	Output HIGH Voltage	2.4	3.6		Volts	$V_{CC} = \text{MIN.}$, $I_{OH} = -0.4 \text{ mA}$ $V_{IN} = V_{IH}$ or V_{IL} per Truth Table
V_{OL}	Output LOW Voltage		0.15	0.3	Volts	$V_{CC} = \text{MIN.}$, $I_{OL} = 4.0 \text{ mA}$ $V_{IN} = V_{IH}$ or V_{IL} per Truth Table
V_{IH}	Input HIGH Voltage	2.0			Volts	Guaranteed Input HIGH Threshold Voltage for All Inputs
V_{IL}	Input LOW Voltage			0.7	Volts	Guaranteed Input LOW Threshold Voltage for All Inputs
I_{IL}	Input LOW Current		-0.25	-0.4	mA	$V_{CC} = \text{MAX.}$, $V_{IN} = 0.3 \text{ V}$
I_{IH}	Input HIGH Current		2.0	20	μA	$V_{CC} = \text{MAX.}$, $V_{IN} = 2.4 \text{ V}$
I_{OH}	Output HIGH Current			1.0	mA	$V_{CC} = \text{MAX.}$, $V_{IN} = 5.5 \text{ V}$
I_{SC} (Note 5)	Output Short Circuit Current	-2.5	-16	-25	mA	$V_{CC} = \text{MAX.}$, $V_{OUT} = 0.0 \text{ V}$
I_{CC}	Power Supply Current		11.5	16.5	mA	$V_{CC} = \text{MAX.}$

NOTES:

- The actual testing procedures used to guarantee the Electrical Characteristics are contained in a detailed Customer Sample Specification. A copy of this specification can be obtained from Fairchild Digital Product Marketing, Mountain View, California.
- Conditions for testing, not shown in the table, are chosen to guarantee operation under "worst case" conditions.
- The specified LIMITS represent the "worst case" value for the parameter. Since these "worst case" values normally occur at the temperature and supply voltage extremes, additional noise immunity and guard banding can be achieved by decreasing the allowable system operating ranges.
- Typical limits are at $V_{CC} = 5.0 \text{ V}$, 25°C , and maximum loading.
- Not more than one output should be shorted at a time.

SWITCHING CHARACTERISTICS ($T_A = 25^\circ\text{C}$)

SYMBOL	PARAMETER	LIMITS			UNITS	CONDITIONS
		MIN.	TYP.	MAX.		
t_{PLH}	Turn Off Delay A Input to Output		50	75	ns	$V_{CC} = 5.0 \text{ V}$ $C_L = 15 \text{ pF}$ See Fig. 1
t_{PHL}	Turn On Delay A Input to Output		60	85	ns	
t_{PLH}	Turn Off Delay \bar{E} Input to Output		30	60	ns	
t_{PHL}	Turn On Delay \bar{E} Input to Output		43	65	ns	

SWITCHING TIME WAVEFORMS

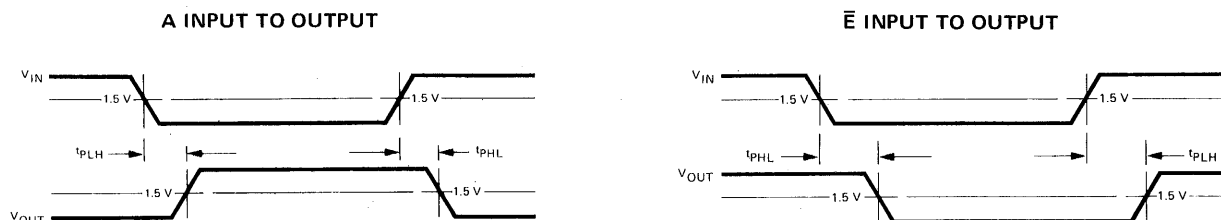

Fig. 1.

TTL/MSI 9312

EIGHT-INPUT MULTIPLEXER

DESCRIPTION — The 9312 is a monolithic, high speed, Eight-Input digital Multiplexer circuit. It provides in one package the ability to select one bit of data from up to eight sources. The 9312 can be used as a universal function generator to generate any logic function of four variables. Both assertion and negation outputs are provided. TTL circuitry with active pullups on the outputs provides high speed, high fanout operation and is compatible with all other members of the Fairchild TTL family.

- MULTIFUNCTION CAPABILITY
- 25 ns THROUGH DELAY
- ON-CHIP SELECT LOGIC DECODING
- FULLY BUFFERED COMPLEMENTARY OUTPUTS
- THE INPUT/OUTPUT CHARACTERISTICS PROVIDE EASY INTERFACING WITH FAIRCHILD DTL, LPDTL, TTL, and MSI FAMILIES
- INPUT CLAMP DIODES LIMIT HIGH SPEED TERMINATION EFFECTS

PIN NAMES

S_0, S_1, S_2	Select Inputs
\bar{E}	Enable (Active LOW) Input
I_0 to I_7	Multiplexer Inputs
Z	Multiplexer Output (Note b)
\bar{Z}	Complementary Multiplexer Output (Note b)

LOADING

(Note a)

I_0 to I_7	1 U.L.
\bar{E}	1 U.L.
Z	10 U.L.
\bar{Z}	10 U.L.

NOTES:

- 1 Unit Load (U.L.) = 40 μ A HIGH/1.6mA LOW.
- 10 U.L. is the output LOW drive factor and 20 U.L. is the output HIGH drive factor.

LOGIC DIAGRAM

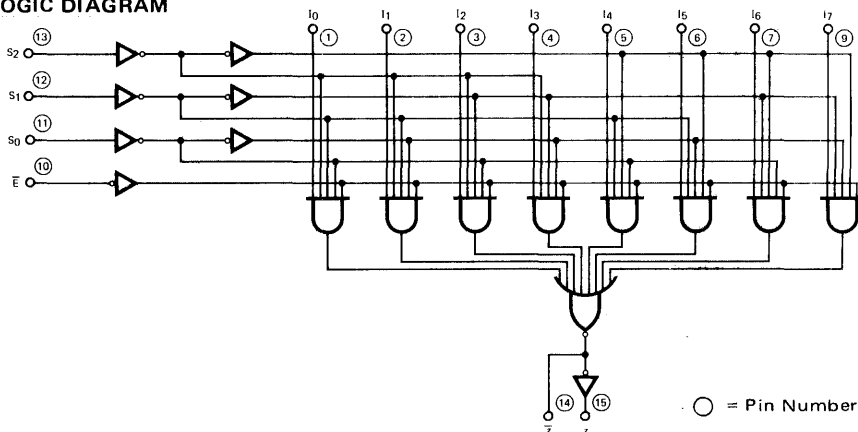

LOGIC SYMBOL

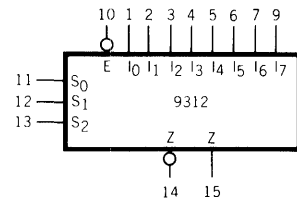

V_{CC} = Pin 16
GND = Pin 8

CONNECTION DIAGRAMS

DIP (TOP VIEW)

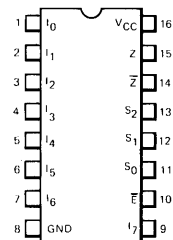

FLATPAK (TOP VIEW)

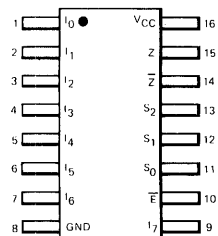

FUNCTIONAL DESCRIPTION – The 9312 is a logical implementation of a single pole, eight position switch with the switch position controlled by the state of three Select Inputs, S_0, S_1, S_2 . Both assertion and negation outputs are provided. The Enable Input (\bar{E}) is active LOW. When it is not activated the negation output is HIGH and the assertion output is LOW, regardless of all other inputs. The logic function provided at the output is:

$$Z = E \cdot (I_0 \cdot \bar{S}_0 \cdot \bar{S}_1 \cdot \bar{S}_2 + I_1 \cdot S_0 \cdot \bar{S}_1 \cdot \bar{S}_2 + I_2 \cdot \bar{S}_0 \cdot S_1 \cdot \bar{S}_2 + I_3 \cdot S_0 \cdot S_1 \cdot \bar{S}_2 + I_4 \cdot \bar{S}_0 \cdot \bar{S}_1 \cdot S_2 + I_5 \cdot S_0 \cdot \bar{S}_1 \cdot S_2 + I_6 \cdot \bar{S}_0 \cdot S_1 \cdot S_2 + I_7 \cdot S_0 \cdot S_1 \cdot S_2).$$

The 9312 provides the ability, in one package, to select from eight sources of data or control information. By proper manipulation of the inputs, the 9312 can provide any logic function of four variables and its negation. Thus any number of random logic elements used to generate unusual truth tables can be replaced by one 9312.

TRUTH TABLE

\bar{E}	S_2	S_1	S_0	I_0	I_1	I_2	I_3	I_4	I_5	I_6	I_7	\bar{Z}	Z
H	X	X	X	X	X	X	X	X	X	X	X	H	L
L	L	L	L	L	X	X	X	X	X	X	X	H	L
L	L	L	L	H	X	X	X	X	X	X	X	L	H
L	L	L	H	X	L	X	X	X	X	X	X	H	L
L	L	L	H	X	H	X	X	X	X	X	X	L	H
L	L	H	L	X	X	L	X	X	X	X	X	H	L
L	L	H	L	X	X	H	X	X	X	X	X	L	H
L	L	H	H	X	X	X	L	X	X	X	X	H	L
L	L	H	H	X	X	X	H	X	X	X	X	L	H
L	L	H	H	X	X	X	X	X	X	X	X	H	L
L	H	L	L	X	X	X	X	L	X	X	X	H	L
L	H	L	L	X	X	X	X	H	X	X	X	L	H
L	H	L	H	X	X	X	X	X	L	X	X	H	L
L	H	L	H	X	X	X	X	X	H	X	X	L	H
L	H	H	L	X	X	X	X	X	X	L	X	H	L
L	H	H	L	X	X	X	X	X	X	H	X	L	H
L	H	H	H	X	X	X	X	X	X	X	L	H	L
L	H	H	H	X	X	X	X	X	X	X	H	L	H

H = HIGH voltage level
L = LOW voltage level
X = Level does not affect output.

TYPICAL INPUT AND OUTPUT CHARACTERISTICS

EQUIVALENT INPUT CIRCUIT

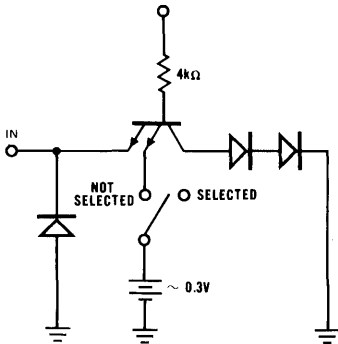

OUTPUT HIGH EQUIVALENT CIRCUIT

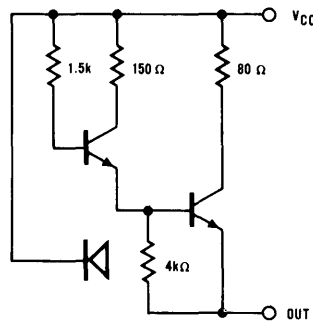

OUTPUT LOW EQUIVALENT CIRCUIT

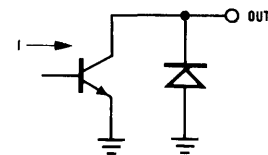

INPUT CURRENT VERSUS INPUT VOLTAGE

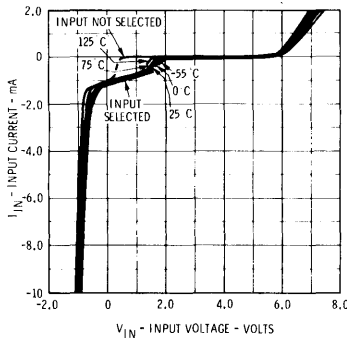

Fig. 1

OUTPUT CURRENT VERSUS OUTPUT VOLTAGE (OUTPUT HIGH)

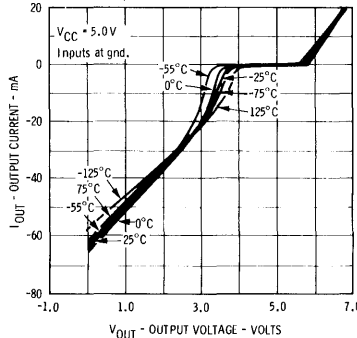

Fig. 2

OUTPUT CURRENT VERSUS OUTPUT VOLTAGE (OUTPUT LOW)

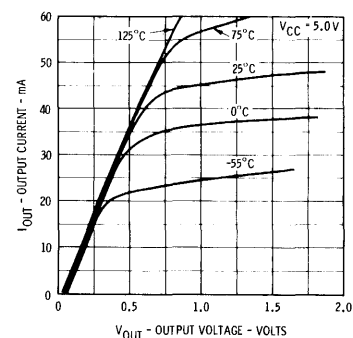

Fig. 3

FAIRCHILD TTL/MSI • 9312

ABSOLUTE MAXIMUM RATINGS (above which the useful life may be impaired)

Storage Temperature	-65°C to +150°C
Temperature (Ambient) Under Bias	-55°C to +125°C
V _{CC} Pin Potential to Ground Pin	-0.5V to +7.0V
*Input Voltage (dc)	-0.5V to +5.5V
*Input Current (dc)	-30mA to +5.0mA
Voltage Applied to Outputs (Output HIGH)	-0.5V to +V _{CC} value
Output Current (dc) (Output LOW)	+30mA

*Either Input Voltage Limit or Input Current is sufficient to protect the inputs.

GUARANTEED OPERATING RANGES

PART NUMBER	SUPPLY VOLTAGE (V _{CC})			TEMPERATURE
	MIN.	TYP.	MAX.	
9312XM.	4.5V	5.0V	5.5V	-55°C to 125°C
9312XC	4.75V	5.0V	5.25V	0°C to 75°C

X = package type; F for Flatpak, D for Ceramic Dip, P for Plastic Dip. See Packaging Information Section for packages available on this product.

ELECTRICAL CHARACTERISTICS OVER OPERATING TEMPERATURE RANGE (unless otherwise noted)

SYMBOL	PARAMETER	LIMITS			UNITS	CONDITIONS
		MIN.	TYP. (Note 4)	MAX.		
V _{IH}	Input HIGH Voltage	2.0			Volts	Guaranteed Input HIGH Threshold Voltage for all Inputs
V _{IL}	Input LOW Voltage			0.8	Volts	Guaranteed Input LOW Threshold Voltage for all Inputs
V _{CD}	Input Clamp Diode Voltage			-1.5	Volts	V _{CC} = MIN., I _{IN} = -12mA, T _A = 25°C
V _{OH}	Output HIGH Voltage	2.4	3.6		Volts	V _{CC} = MIN., I _{OH} = -800μA V _{IN} = V _{IH} or V _{IL} per Truth Table
V _{OL}	Output LOW Voltage		0.2	0.4	Volts	V _{CC} = MIN., I _{OL} = 16mA V _{IN} = V _{IH} or V _{IL} per Truth Table
I _{IH}	Input HIGH Current		10	40	μA	V _{CC} = MAX., V _{IN} = 2.4V
				1.0	mA	V _{CC} = MAX., V _{IN} = 5.0V
I _{IL}	Input LOW Current		-0.96	-1.6	mA	V _{CC} = MAX., V _{IN} = 0.4V
I _{SC} (I _{OS})	Output Short Circuit Current (Note 5)	-30	-60	-100	mA	V _{CC} = MAX., V _{OUT} = 0.0V
I _{CC}	Power Supply Current		27	44	mA	V _{CC} = MAX.

NOTES:

1. The actual testing procedures used to guarantee the Electrical Characteristics are contained in a detailed Customer Sample Specification. A copy of this specification can be obtained from Fairchild Digital Product Marketing, Mountain View, California.
2. Conditions for testing, not shown in the table, are chosen to guarantee operation under "worst case" conditions.
3. The specified LIMITS represent the "worst case" value for the parameter. Since these "worst case" values normally occur at the temperature and supply voltage extremes, additional noise immunity and guard banding can be achieved by decreasing the allowable system operating ranges.
4. Typical limits are at V_{CC} = 5.0 V, 25°C, and maximum loading.
5. Not more than one output should be shorted at a time.

SWITCHING CHARACTERISTICS (T_A = 25°C)

SYMBOL	PARAMETER	LIMITS			UNITS	TEST CONDITIONS
		MIN.	TYP.	MAX.		
t _{PLH}	Turn Off Delay Input to Output (S ₀ to Z)		23	34	ns	V _{CC} = 5.0V C _L = 15 pF (See following page)
t _{PHL}	Turn On Delay Input to Output (S ₀ to Z)		25	36	ns	

SWITCHING CHARACTERISTICS

$t_{PLH}/t_{PHL} : S_0 \text{ to } Z$

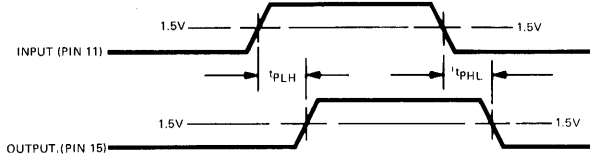

OTHER CONDITIONS: Pins 1, 8, 10, 12, 13 = GND
Pin 2 = V_{CC} through 1 k Ω
Pin 16 = V_{CC}

TURN OFF DELAY VERSUS AMBIENT TEMPERATURE;
 $S_0 \text{ to } Z$

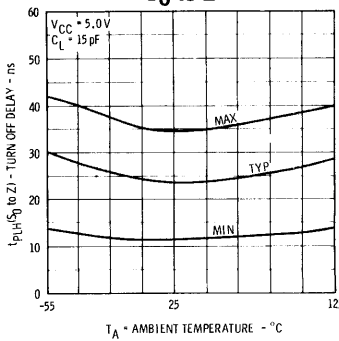

Fig. 4

TURN ON DELAY VERSUS AMBIENT TEMPERATURE;
 $S_0 \text{ to } Z$

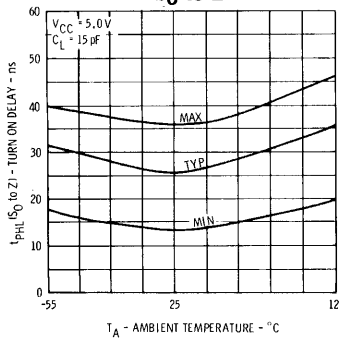
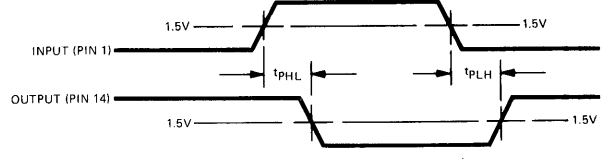

Fig. 5

$t_{PLH}/t_{PHL} : I_0 \text{ to } \bar{Z}$



OTHER CONDITIONS: Pins 8, 10, 11, 12, 13 = GND
Pin 16 = V_{CC}

TURN OFF DELAY VERSUS AMBIENT TEMPERATURE;
 $I_0 \text{ to } \bar{Z}$

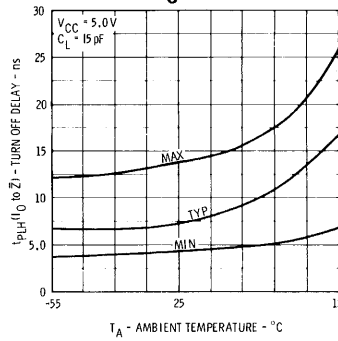

Fig. 6

TURN ON DELAY VERSUS AMBIENT TEMPERATURE;
 $I_0 \text{ to } \bar{Z}$

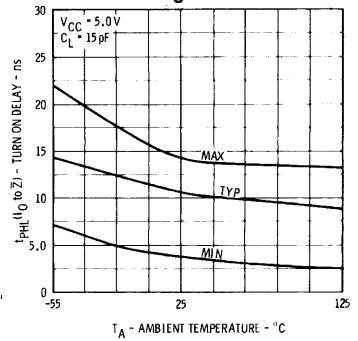
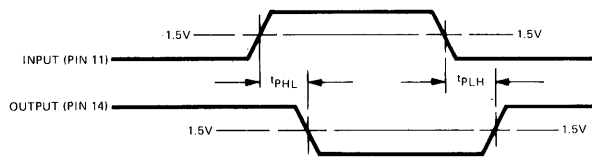

Fig. 7

$t_{PLH}/t_{PHL} : S_0 \text{ to } \bar{Z}$



OTHER CONDITIONS: Pins 1, 8, 10, 12, 13 = GND
Pin 2 = V_{CC} through 1 k Ω
Pin 16 = V_{CC}

TURN OFF DELAY VERSUS AMBIENT TEMPERATURE;
 $S_0 \text{ to } \bar{Z}$

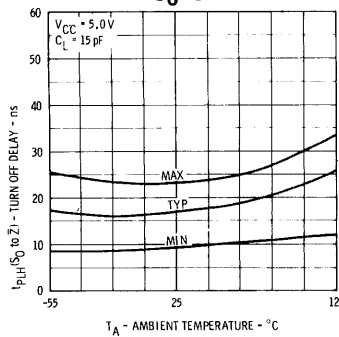

Fig. 8

TURN ON DELAY VERSUS AMBIENT TEMPERATURE;
 $S_0 \text{ to } \bar{Z}$

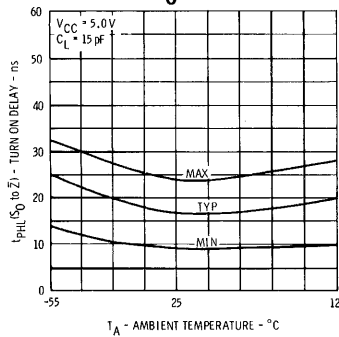
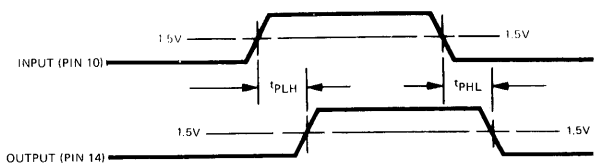

Fig. 9

$t_{PLH}/t_{PHL} : \bar{E} \text{ to } \bar{Z}$



OTHER CONDITIONS: Pins 8, 11, 12, 13 = GND
Pin 1 = V_{CC} through 1 k Ω
Pin 16 = V_{CC}

TURN OFF DELAY VERSUS AMBIENT TEMPERATURE;
 $\bar{E} \text{ to } \bar{Z}$

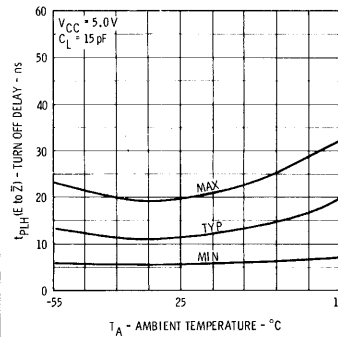

Fig. 10

TURN ON DELAY VERSUS AMBIENT TEMPERATURE;
 $\bar{E} \text{ to } \bar{Z}$

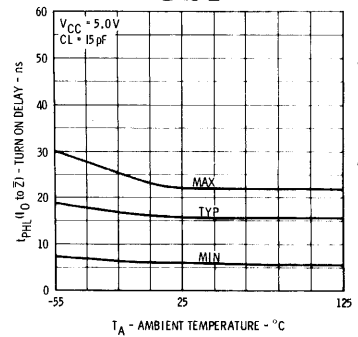

Fig. 11

LPTTL/MSI 93L12

LOW POWER EIGHT-INPUT MULTIPLEXER

DESCRIPTION – The LPTTL/MSI 93L12 is a monolithic, medium speed, eight input digital Multiplexer. It provides in one package the ability to select one bit of data from up to eight sources. The 93L12 can be used as a universal function generator to generate any logic function of four variables. Both assertion and negation outputs are provided. TTL circuitry with active pullups on the outputs provides high speed, high fanout operation and is compatible with the Fairchild TTL family.

- MULTIFUNCTION CAPABILITY •
- ON-CHIP SELECT LOGIC DECODING
- FULLY BUFFERED COMPLEMENTARY OUTPUTS
- TYPICAL PROPAGATION DELAY OF 80 ns
- TYPICAL POWER DISSIPATION OF 45 mW
- INPUT CLAMP DIODES LIMIT HIGH SPEED TERMINATION EFFECTS
- ALL CERAMIC "HERMETIC" 16-LEAD DUAL IN-LINE AND FLAT PACKAGES
- TTL COMPATIBLE

PIN NAMES

S_0, S_1, S_2	Select Inputs
\bar{E}	Enable (Active LOW) Input
I_0 to I_7	Multiplexer Inputs
Z	Multiplexer Output
\bar{Z}	Complementary Multiplexer Output

LOADING	
HIGH	LOW
0.5 U.L.	0.25 U.L.
0.5 U.L.	0.25 U.L.
0.5 U.L.	0.25 U.L.
10 U.L.	2.5 U.L.
10 U.L.	2.25 U.L.

1 Unit Load (U.L.) = 40 μ A HIGH/1.6 mA LOW

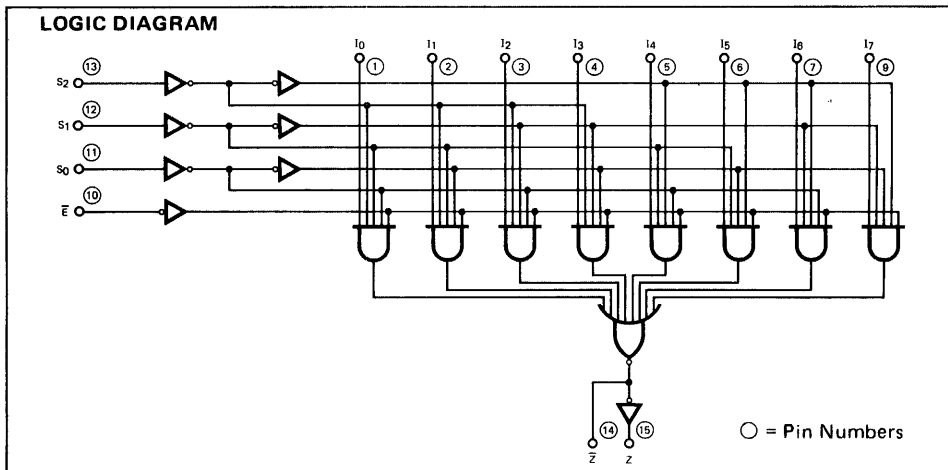

LOGIC SYMBOL

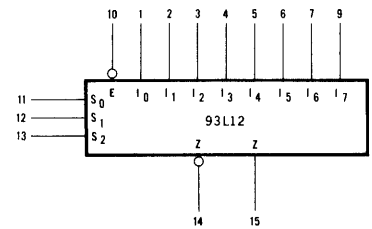

V_{CC} = Pin 16
Gnd = Pin 8

CONNECTION DIAGRAMS DIP (TOP VIEW)

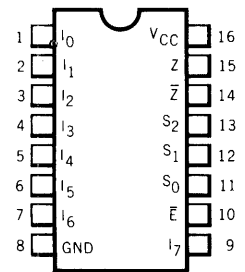

FLATPAK (TOP VIEW)

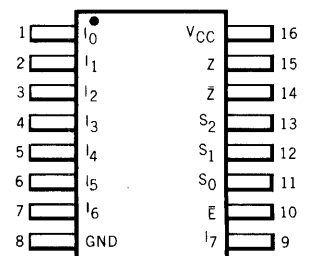

FAIRCHILD LPTTL/MSI • 93L12

FUNCTIONAL DESCRIPTION – The 93L12 is a logical implementation of a single pole, eight position switch with the switch position controlled by the state of three select inputs, S_0, S_1, S_2 . Both assertion and negation outputs are provided. The enable input (\bar{E}) is active LOW. When it is not activated the negation output is HIGH and the assertion output is LOW regardless of all other inputs. The logic function provided at the output is:

$$Z = E \cdot (I_0 \cdot \bar{S}_0 \cdot \bar{S}_1 \cdot \bar{S}_2 + I_1 \cdot S_0 \cdot \bar{S}_1 \cdot \bar{S}_2 + I_2 \cdot \bar{S}_0 \cdot S_1 \cdot \bar{S}_2 + I_3 \cdot S_0 \cdot S_1 \cdot \bar{S}_2 + I_4 \cdot \bar{S}_0 \cdot \bar{S}_1 \cdot S_2 + I_5 \cdot S_0 \cdot \bar{S}_1 \cdot S_2 + I_6 \cdot \bar{S}_0 \cdot S_1 \cdot S_2 + I_7 \cdot S_0 \cdot S_1 \cdot S_2).$$

The 93L12 provides the ability, in one package, to select from eight sources of data or control information. By proper manipulation of the inputs, the 93L12 can provide any logic function of four variables and its negation.

TRUTH TABLE

\bar{E}	S_2	S_1	S_0	I_0	I_1	I_2	I_3	I_4	I_5	I_6	I_7	\bar{Z}	Z
H	X	X	X	X	X	X	X	X	X	X	X	H	L
L	L	L	L	L	X	X	X	X	X	X	X	H	L
L	L	L	L	H	X	X	X	X	X	X	X	L	H
L	L	L	H	X	L	X	X	X	X	X	X	H	L
L	L	L	H	X	H	X	X	X	X	X	X	L	H
L	L	H	L	X	X	L	X	X	X	X	X	H	L
L	L	H	L	X	X	H	X	X	X	X	X	L	H
L	L	H	H	X	X	X	L	X	X	X	X	H	L
L	L	H	H	X	X	X	H	X	X	X	X	L	H
L	H	L	L	X	X	X	X	L	X	X	X	H	L
L	H	L	L	X	X	X	X	H	X	X	X	L	H
L	H	L	H	X	X	X	X	X	L	X	X	H	L
L	H	L	H	X	X	X	X	X	H	X	X	L	H
L	H	H	L	X	X	X	X	X	X	L	X	H	L
L	H	H	L	X	X	X	X	X	X	H	X	L	H
L	H	H	H	X	X	X	X	X	X	X	L	H	L
L	H	H	H	X	X	X	X	X	X	X	H	L	H

H = HIGH Voltage Level
L = LOW Voltage Level
X = Level does not affect output

TYPICAL INPUT AND OUTPUT CIRCUITS

**INPUTS
EQUIVALENT CIRCUIT**

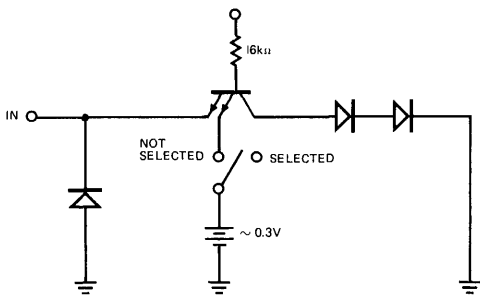

**OUTPUTS
EQUIVALENT CIRCUIT**

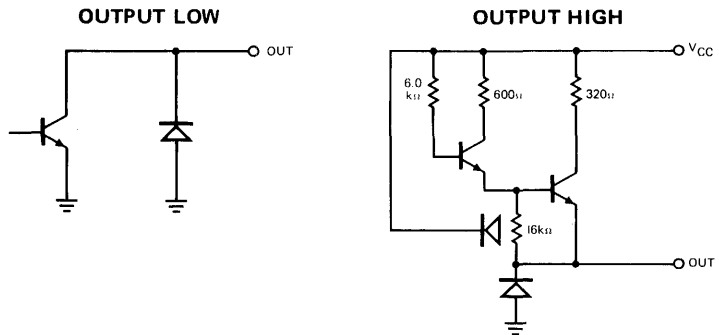

ABSOLUTE MAXIMUM RATINGS (above which the useful life may be impaired)

Storage Temperature	–65°C to +150°C
Temperature (Ambient) Under Bias	–55°C to +125°C
V _{CC} Pin Potential to Ground Pin	–0.5 V to +7.0 V
*Input Voltage (dc)	–0.5 V to +5.5 V
*Input Current (dc)	–30 mA to +5.0 mA
Voltage Applied to Outputs (Output HIGH)	–0.5 V to +V _{CC} value
Output Current (dc) (Output LOW)	+30 mA

*Either Input Voltage limit or Input Current limit is sufficient to protect the inputs.

FAIRCHILD LPTTL/MSI • 93L12

GUARANTEED OPERATING RANGES

PART NUMBER	SUPPLY VOLTAGE (V _{CC})			TEMPERATURE
	MIN.	TYP.	MAX.	
93L12XM	4.5 V	5.0 V	5.5 V	-55°C to 125°C
93L12XC	4.75 V	5.0 V	5.25 V	0°C to 75°C

X = package type; F for Flatpak, D for Ceramic Dip, P for Plastic Dip. See Packaging Information Section for packages available on this product.

ELECTRICAL CHARACTERISTICS OVER OPERATING TEMPERATURE RANGE (Unless Otherwise Noted)

SYMBOL	PARAMETER	LIMITS			UNITS	CONDITIONS
		MIN.	TYP. (Note 4)	MAX.		
V _{OH}	Output HIGH Voltage	2.4	3.6		Volts	V _{CC} = MIN., I _{OH} = -0.4 mA V _{IN} = V _{IH} or V _{IL} per Truth Table
V _{OL}	Output LOW Voltage		0.15	0.3	Volts	V _{CC} = MIN., I _{OL} = 4.0 mA (Pin 15) 3.6 mA (Pin 14) V _{IN} = V _{IH} or V _{IL} per Truth Table
V _{IH}	Input HIGH Voltage	2.0			Volts	Guaranteed Input HIGH Threshold Voltage for All Inputs
V _{IL}	Input LOW Voltage			0.7	Volts	Guaranteed Input LOW Threshold Voltage for All Inputs
I _{IL}	Input LOW Current		-0.25	-0.4	mA	V _{CC} = MAX., V _{IN} = 0.3 V
I _{IH}	Input HIGH Current		2.0	20	μA	V _{CC} = MAX., V _{IN} = 2.4 V
				1.0	mA	V _{CC} = MAX., V _{IN} = 5.5 V
I _{SC} (Note 5)	Output Short Circuit Current	-10	-22	-40	mA	V _{CC} = MAX., V _{OUT} = 0.0 V
I _{CC}	Power Supply Current		9.0	13.3	mA	V _{CC} = MAX.

NOTES:

1. The actual testing procedures used to guarantee the Electrical Characteristics are contained in a detailed Customer Sample Specification. A copy of this specification can be obtained from Fairchild Digital Product Marketing, Mountain View, California.
2. Conditions for testing, not shown in the table, are chosen to guarantee operation under "worst case" conditions.
3. The specified LIMITS represent the "worst case" value for the parameter. Since these "worst case" values normally occur at the temperature and supply voltage extremes, additional noise immunity and guard banding can be achieved by decreasing the allowable system operating ranges.
4. Typical limits are at V_{CC} = 5.0 V, 25°C, and maximum loading.
5. Not more than one output should be shorted at a time.

SWITCHING CHARACTERISTICS (T_A = 25°C)

SYMBOL	PARAMETER	LIMITS			UNITS	CONDITIONS
		MIN.	TYP.	MAX.		
t _{PLH} (S ₀ to Z)	Turn Off Delay Input to Output		52	90	ns	V _{CC} = 5.0 V, C _L = 15 pF
t _{PHL} (S ₀ to Z)	Turn On Delay Input to Output		68	105	ns	V _{CC} = 5.0 V, C _L = 15 pF

TTL/MSI 93S12

EIGHT-INPUT MULTIPLEXER

TO BE ANNOUNCED

DESCRIPTION – The 93S12 is a monolithic, super high speed, 8-Input digital Multiplexer circuit utilizing the Schottky TTL process. It provides in one package the ability to select one bit of data from up to eight sources. The 93S12 can be used as a universal function generator to generate any logic function of four variables. Both assertion and negation outputs are provided. TTL circuitry with active pullups on the outputs provides high speed, high fan out operation and is compatible with all other members of the Fairchild TTL family.

- MULTIFUNCTION CAPABILITY
- ON-CHIP SELECT LOGIC DECODING
- FULLY BUFFERED COMPLEMENTARY OUTPUTS
- THE INPUT/OUTPUT CHARACTERISTICS PROVIDE EASY INTERFACING WITH FAIRCHILD DTL, LPDTL, TTL, and MSI FAMILIES
- INPUT CLAMP DIODES LIMIT HIGH SPEED TERMINATION EFFECTS

PIN NAMES

S_0, S_1, S_2	Select Inputs
\bar{E}	Enable (Active LOW) Input
I_0 to I_7	Multiplexer Inputs
Z	Multiplexer Output
\bar{Z}	Complementary Multiplexer Output

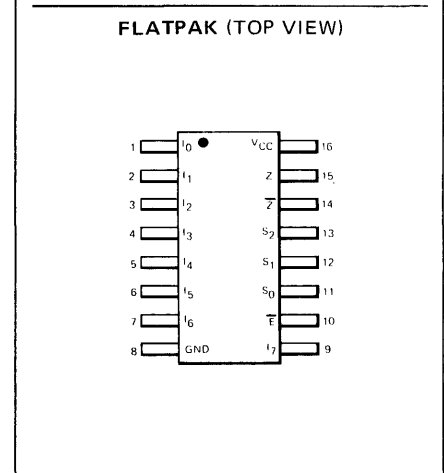
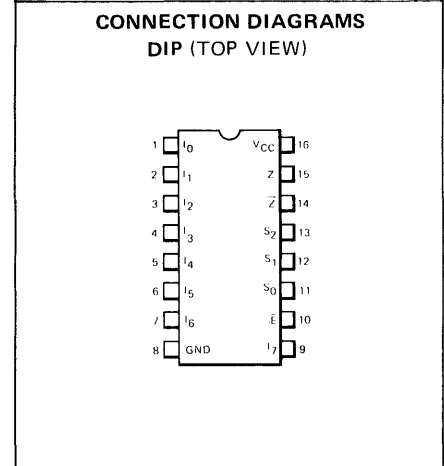
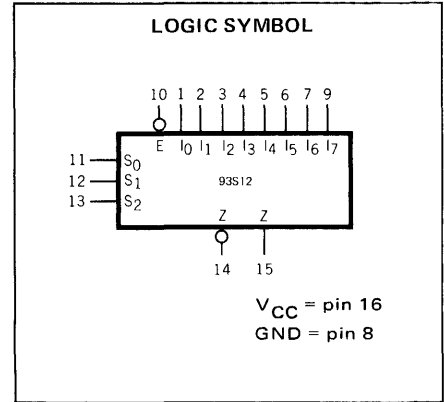
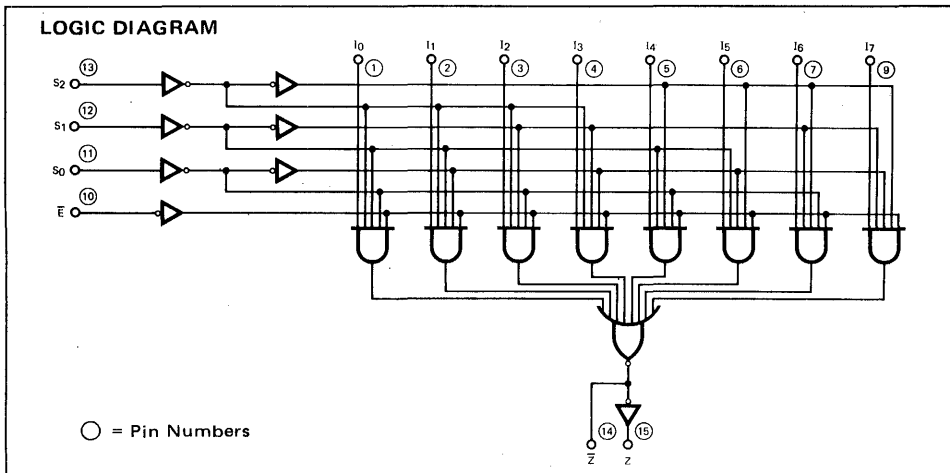

TTL/MSI 9313

EIGHT-INPUT MULTIPLEXER WITH OPEN COLLECTOR OUTPUT

DESCRIPTION — The TTL/MSI 9313 is an 8-Input Multiplexer with open collector output. The 9313 has the same pinning and logic configuration as the 9312, but with an open collector \bar{Z} output which allows for easy expansion of input terms. The device can select one bit of data from up to eight sources. It has an active LOW enable, and internal select decoding. The 9313 is fully compatible with all members of the Fairchild TTL family.

- PIN FOR PIN REPLACEMENT FOR THE SIGNETICS 8231
- SAME PINNING AND LOGIC CONFIGURATION AS THE 9312 BUT WITH OPEN COLLECTOR OUTPUT
- OPEN COLLECTOR OUTPUT \bar{Z} FOR EASY EXPANSION OF INPUT TERMS (WIRED-OR APPLICATIONS)
- MULTIFUNCTION CAPABILITY
- ON-CHIP SELECT LOGIC DECODING
- FULLY BUFFERED Z OUTPUT
- INPUT CLAMP DIODES
- TTL COMPATIBLE

PIN NAMES

S_0, S_1, S_2	Select Inputs	1 U.L.
\bar{E}	Enable (Active LOW) Input	1 U.L.
I_0 to I_7	Multiplexer Inputs	1 U.L.
Z	Multiplexer Output (Note b)	10 U.L.
\bar{Z}	Complementary Open Collector Multiplexer Output (Note c)	10 U.L.

LOADING

(Note a)

NOTES:

- a. 1 Unit Load (U.L.) = 40 μ A HIGH/1.6mA LOW
- b. 10 U.L. is the output LOW drive factor and 20 U.L. is the output HIGH drive factor.
- c. An external pull-up resistor is needed to provide HIGH level drive capability. This output will sink a maximum of 16 mA at $V_{out} = 0.4$ V.

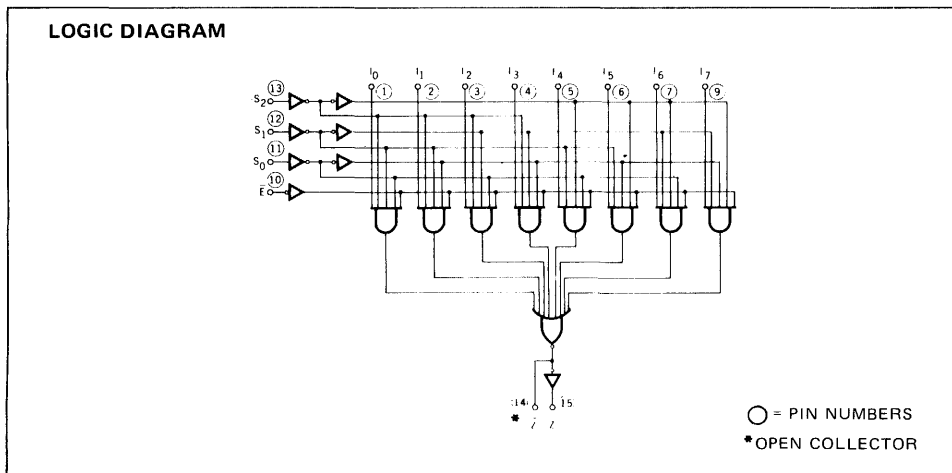
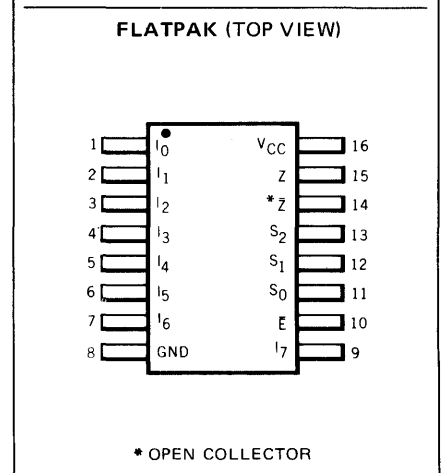
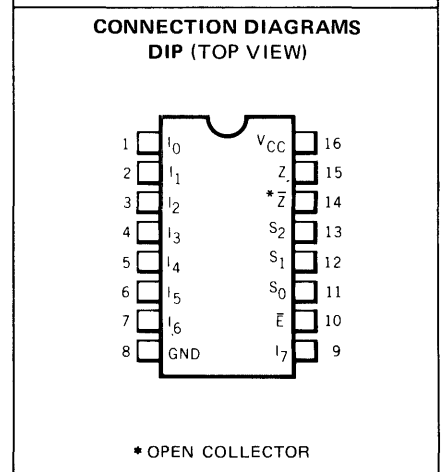
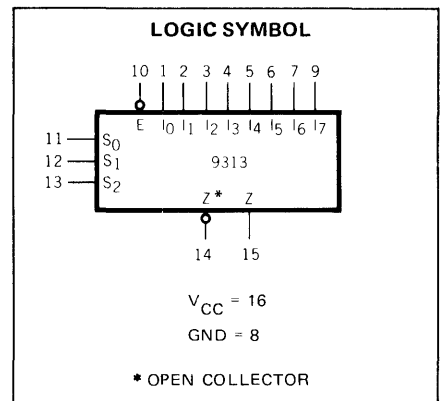

FUNCTIONAL DESCRIPTION — The TTL/MSI 9313 is a logical implementation of a single pole, eight-position switch with the switch position controlled by the state of three Select inputs, S_0, S_1, S_2 . An open collector output \bar{Z} is provided for easy expansion of input terms. Also a fully buffered Z output is available. The Enable input (\bar{E}) is active LOW. When it is not activated the negation output is HIGH and the assertion output is LOW regardless of all other inputs. The logic function provided at the output is:

$$Z = E \cdot (I_0 \cdot \bar{S}_0 \cdot \bar{S}_1 \cdot \bar{S}_2 + I_1 \cdot S_0 \cdot \bar{S}_1 \cdot \bar{S}_2 + I_2 \cdot \bar{S}_0 \cdot S_1 \cdot \bar{S}_2 + I_3 \cdot S_0 \cdot S_1 \cdot \bar{S}_2 + I_4 \cdot \bar{S}_0 \cdot \bar{S}_1 \cdot S_2 + I_5 \cdot S_0 \cdot \bar{S}_1 \cdot S_2 + I_6 \cdot \bar{S}_0 \cdot S_1 \cdot S_2 + I_7 \cdot S_0 \cdot S_1 \cdot S_2)$$

The 9313 provides the ability, in one package, to select from eight sources of data or control information. By proper manipulation of the inputs, the 9313 can provide any logic function of four variables and its negation.

TABLE I TRUTH TABLE

\bar{E}	S_2	S_1	S_0	I_0	I_1	I_2	I_3	I_4	I_5	I_6	I_7	\bar{Z}	Z
H	X	X	X	X	X	X	X	X	X	X	X	H	L
L	L	L	L	L	X	X	X	X	X	X	X	H	L
L	L	L	L	H	X	X	X	X	X	X	X	L	H
L	L	L	H	X	L	X	X	X	X	X	X	H	L
L	L	L	H	X	H	X	X	X	X	X	X	L	H
L	L	H	L	X	X	L	X	X	X	X	X	H	L
L	L	H	L	X	X	H	X	X	X	X	X	L	H
L	L	H	H	X	X	X	L	X	X	X	X	H	L
L	L	H	H	X	X	X	H	X	X	X	X	L	H
L	H	L	L	X	X	X	X	L	X	X	X	H	L
L	H	L	L	X	X	X	X	H	X	X	X	L	H
L	H	L	H	X	X	X	X	X	L	X	X	H	L
L	H	L	H	X	X	X	X	X	H	X	X	L	H
L	H	H	L	X	X	X	X	X	X	L	X	H	L
L	H	H	L	X	X	X	X	X	X	H	X	L	H
L	H	H	H	X	X	X	X	X	X	X	L	H	L
L	H	H	H	X	X	X	X	X	X	X	H	L	H

H = HIGH Voltage Level
 L = LOW Voltage Level
 X = Level Does Not Affect Output

TYPICAL INPUT AND OUTPUT CIRCUITS

INPUTS EQUIVALENT CIRCUIT

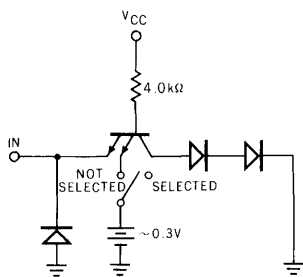

Z Output (Pin 15) EQUIVALENT CIRCUIT

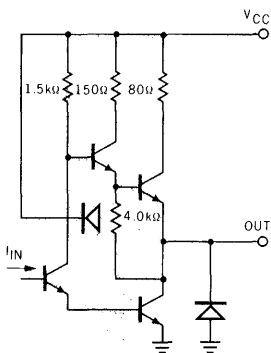

\bar{Z} Output (Pin 14) EQUIVALENT CIRCUIT

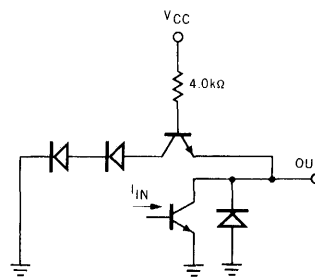

ABSOLUTE MAXIMUM RATINGS (above which the useful life may be impaired)

Storage Temperature	-65°C to +150°C
Temperature (Ambient) Under Bias	-55°C to +125°C
V _{CC} Pin Potential to Ground Pin	-0.5V to +7.0V
*Input Voltage (dc)	-0.5V to +5.5V
*Input Current (dc)	-30 mA to +5.0 mA
Voltage Applied to Outputs (Output HIGH)	-0.5V to +V _{CC} value
Output Current (dc) (Output LOW)	+30 mA

*Either Input Voltage limit or Input Current limit is sufficient to protect the inputs.

GUARANTEED OPERATING RANGES

PART NUMBER	SUPPLY VOLTAGE (V _{CC})			TEMPERATURE
	MIN.	TYP.	MAX.	
9313XM	4.5V	5.0V	5.5V	-55°C to 125°C
9313XC	4.75V	5.0V	5.25V	0°C to 75°C

X = package type; F for Flatpak, D for Ceramic Dip, P for Plastic Dip. See Packaging Information Section for packages available on this product.

ELECTRICAL CHARACTERISTICS OVER OPERATING TEMPERATURE RANGE (unless otherwise noted)

SYMBOL	PARAMETER	LIMITS			UNITS	CONDITIONS
		MIN.	TYP. (Note 4)	MAX.		
V _{OH}	Output HIGH Voltage on Z (Pin 15)	2.4	3.6		Volts	V _{CC} = MIN., I _{OH} = -800 μA V _{IN} = V _{IH} or V _{IL} per Truth Table
V _{OL}	Output LOW Voltage		0.25	0.4	Volts	V _{CC} = MIN., I _{OL} = 16 mA V _{IN} = V _{IH} or V _{IL} per Truth Table
V _{IH}	Input HIGH Voltage	2.0			Volts	Guaranteed input logical HIGH voltage for all inputs
V _{IL}	Input LOW Voltage			0.8	Volts	Guaranteed input logical LOW voltage for all inputs
I _{IL}	Input LOW Current		-1.0	-1.6	mA	V _{CC} = MAX., V _{IN} = 0.4V
I _{IH}	Input HIGH Current		5.0	40	μA	V _{CC} = MAX., V _{IN} = 2.4V
			0.02	1.0	mA	V _{CC} = MAX., V _{IN} = 5.5V
I _{CEX}	Output HIGH Leakage Current on \bar{Z} (Pin 14)		5.0	150	μA	V _{CC} = 4.5V, V _{OUT} = 4.5V, V _{IN} = 0.6V on Data Input V _{IN} (E & S Inputs) = V _{IL} or V _{IH} per Truth Table
I _{SC}	Output Short Circuit Current on Z (Pin 15)	-30	-75	-100	mA	V _{CC} = MAX., V _{OUT} = 0.0V
I _{CC}	Power Supply Current		28	47	mA	V _{CC} = MAX., I _{Q-17} = GND
V _{CD}	Input Clamp Diode Voltage			-1.5	Volts	V _{CC} = MIN., I _{IN} = -12 mA, T _A = 25°C

NOTES:

- (1) The actual testing procedures used to guarantee the Electrical Characteristics are contained in a detailed Customer Sample Specification. A copy of this specification can be obtained from Fairchild Digital Product Marketing, Mountain View, California.
- (2) Conditions for testing, not shown in the Table, are chosen to guarantee operation under "worst case" conditions.
- (3) The specified LIMITS represent the "worst case" value for the parameter. Since these "worst case" values normally occur at the temperature and supply voltage extremes, additional noise immunity and guard banding can be achieved by decreasing the allowable system operating ranges.
- (4) Typical limits are at V_{CC} = 5.0 V, 25°C, and max. loading.

SWITCHING CHARACTERISTICS (T_A = 25°C)

SYMBOL	PARAMETER	LIMITS				UNITS	CONDITIONS
		9313XM(MIL)		9313XC(IND)			
		TYP.	MAX.	TYP.	MAX.		
t _{PLH} (S ₀ to Z)	Turn Off Delay Input to Output	25	32	25	36	ns	V _{CC} = 5.0V C _T = C _L = 15 pF, R _X = 400 Ω to V _{CC}
t _{PHL} (S ₀ to Z)	Turn On Delay Input to Output	33	40	33	45	ns	

SWITCHING CHARACTERISTIC CURVES

All measurements are made with $V_{CC} = 5.0$ V applied to pin 16 and with pin 8 grounded.

$t_{PLH} / t_{PHL} : S_0 \text{ to } Z$

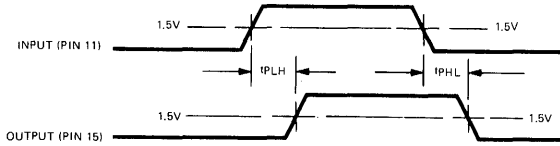

OTHER CONDITIONS: Pins 1, 8, 10, 12, 13 = GND
Pin 2 = V_{CC} through 1.0 k Ω
Pin 16 = V_{CC}

$t_{PLH} / t_{PHL} : I_0 \text{ to } Z$

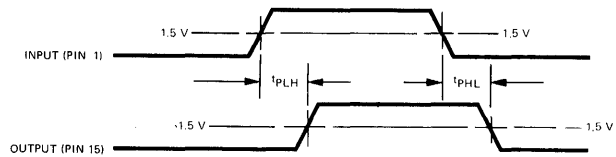

OTHER CONDITIONS: Pins 8, 10, 11, 12, 13 = GND
Pin 16 = V_{CC}

TURN OFF DELAY VERSUS AMBIENT TEMPERATURE; $S_0 \text{ to } Z$

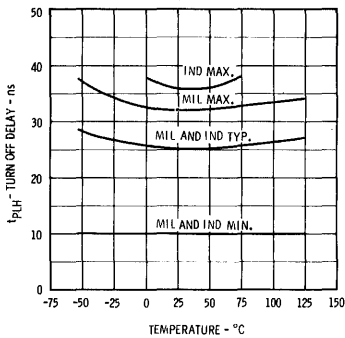

Fig. 1

TURN ON DELAY VERSUS AMBIENT TEMPERATURE; $S_0 \text{ to } Z$

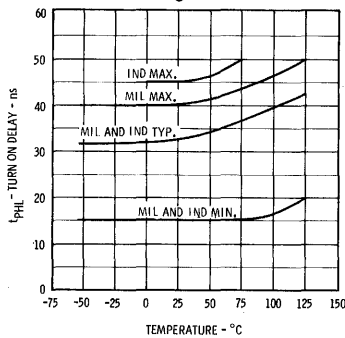

Fig. 2

TURN OFF DELAY VERSUS AMBIENT TEMPERATURE; $I_0 \text{ to } Z$

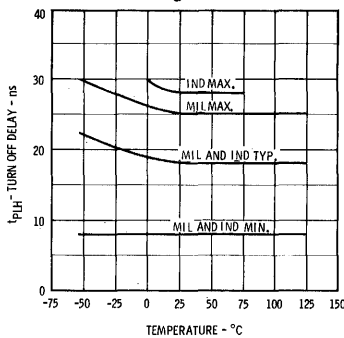

Fig. 3

TURN ON DELAY VERSUS AMBIENT TEMPERATURE; $I_0 \text{ to } Z$

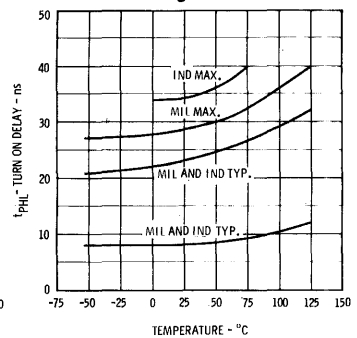
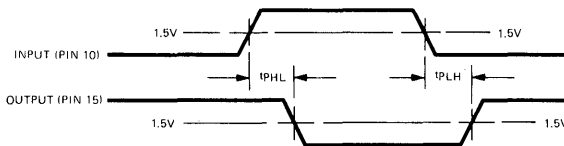

Fig. 4

$t_{PLH} / t_{PHL} : \bar{E} \text{ to } Z$



OTHER CONDITIONS: Pins 8, 11, 12, 13 = GND
Pin 1 = V_{CC} through 1.0 k Ω
Pin 16 = V_{CC}

$t_{PLH} / t_{PHL} : S_0 \text{ to } \bar{Z}$

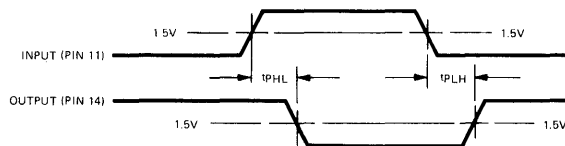

OTHER CONDITIONS: Pins 1, 8, 10, 12, 13 = GND
Pin 2 = V_{CC} through 1.0 k Ω
Pin 16 = V_{CC}

TURN OFF DELAY VERSUS AMBIENT TEMPERATURE; $\bar{E} \text{ to } Z$

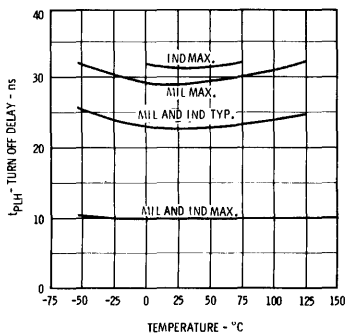

Fig. 5

TURN ON DELAY VERSUS AMBIENT TEMPERATURE; $\bar{E} \text{ to } Z$

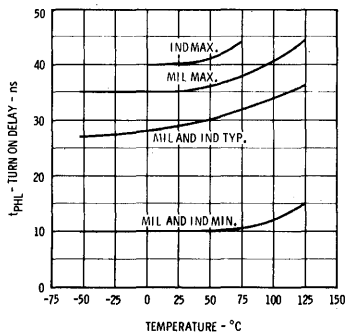

Fig. 6

TURN OFF DELAY VERSUS AMBIENT TEMPERATURE; $S_0 \text{ to } \bar{Z}$

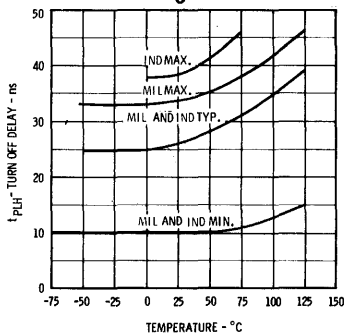

Fig. 7

TURN ON DELAY VERSUS AMBIENT TEMPERATURE; $S_0 \text{ to } \bar{Z}$

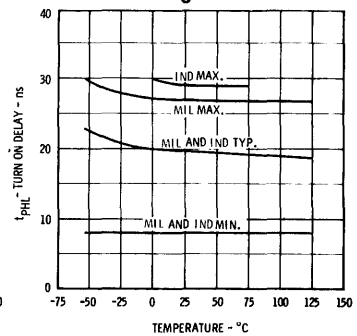

Fig. 8

WIRED-OR APPLICATIONS

It is possible to perform the "Wired OR" function by connecting the open collector \bar{Z} outputs together and adding an external pull up resistor.

The value of the pull up is determined by considering the fanout of the "OR Tie" and the number of devices in the "OR Tie". The pull up resistor value is chosen from a range between a maximum value (determined such that the required V_{OH} is maintained with all the OR tied outputs off) and a minimum value (determined such that with only one output on in the "OR-Tie", its fanout is not exceeded).

Minimum and Maximum Pull up Values

$$R_x (\text{Min.}) = \frac{V_{CC} (\text{max.}) - V_{OL}}{I_{OL} - N_2 I_{IL} - (N_1 - 1) I_{IL}}$$

$$R_x (\text{Max.}) = \frac{V_{CC} (\text{min.}) - V_{OH}}{N_1 I_{CEX} + N_2 I_{IH}}$$

Where

- N_1 = Number of "Wired OR" Outputs
- N_2 = Fanout of "OR Tie"
- V_{CC} = Power Supply Voltage
- R_x = External Pull-up Resistor
- I_{CEX} = Output HIGH Leakage Current on \bar{Z} (150 μA)
- I_{IH} = Input HIGH Current (40 μA)
- I_{IL} = Input LOW Current (1.6 mA)
- V_{OL} = Output LOW Voltage (0.4 V)
- V_{OH} = Output HIGH Voltage (2.4 V)
- I_{OL} = Maximum Current Sinking Capability of Single Output (16 mA)

Example R_L (Min) and R_L (Max.) for four 9313's OR Tied and driving 1 TTL gate. (Industrial V_{CC} tolerances used)

$$R_x (\text{Min.}) = \frac{5.25 \text{ V} - 0.4 \text{ V}}{16 \text{ mA} - 1 (1.6 \text{ mA}) - (4 - 1) 1.6 \text{ mA}} = \frac{4.85 \text{ V}}{9.6 \text{ mA}} = 505 \Omega$$

$$R_x (\text{Max.}) = \frac{4.75 \text{ V} - 2.4 \text{ V}}{4 (150 \mu\text{A}) + 1 (40 \mu\text{A})} = \frac{2.35 \text{ V}}{640 \mu\text{A}} = 3.7 \text{ k}\Omega$$

The pull up resistor value (\pm resistor tolerance) selected should be between these max. and min. values.

Minimum propagation delay results when the minimum value of external pull-up resistor is used in circuit 1. Diodes should be fast recovery 1N4376 or equivalent. External pull-up resistor circuits 2 and 3 give progressively slower propagation delays. (See Figures 9 and 10.)

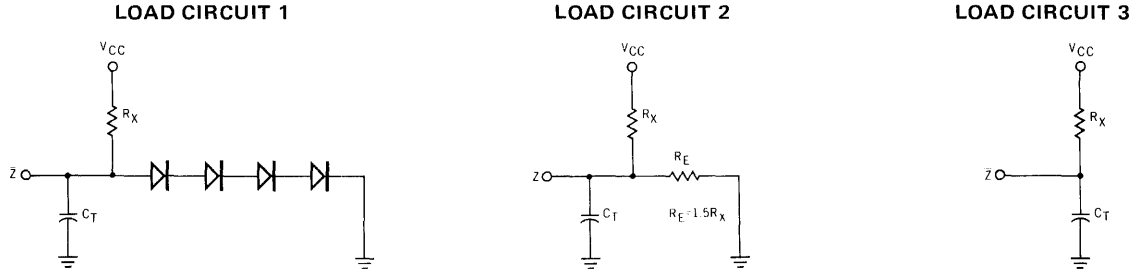

C_T = Total Capacitance at Output

SWITCHING DELTA FOR TURN OFF DELAY (Δt_{pLH}) ANY INPUT TO Z OUTPUT, VERSUS LOAD CAPACITANCE (C_T)

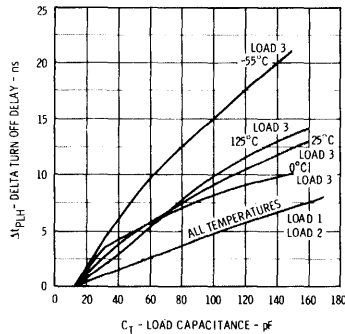

Fig. 9

SWITCHING DELTA FOR TURN ON DELAY (Δt_{pHL}) ANY INPUT TO Z OUTPUT, VERSUS LOAD CAPACITANCE (C_T)

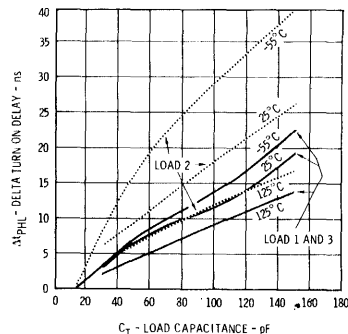

Fig. 10

TTL/MSI 9314

QUAD LATCH

DESCRIPTION – The MSI 9314 is a multifunctional 4-Bit Latch. The latch is designed for general purpose storage applications in high speed digital systems. All inputs feature diode clamping to reduce negative line transients. All outputs have active pull-up circuitry to provide high capacitance drive and to provide low impedance in both logic states for good ac noise immunity.

- CAN BE USED AS SINGLE INPUT D LATCHES OR SET/RESET LATCHES
- ACTIVE LEVEL LOW ENABLE GATE INPUT
- OVERRIDING MASTER RESET
- 25 ns THROUGH DELAY
- THE INPUT/OUTPUT CHARACTERISTICS PROVIDE DIRECT INTERFACING WITH FAIRCHILD DTL, LPDTL, TTL, AND MSI FAMILIES[®]
- INPUT CLAMP DIODES LIMIT HIGH SPEED TERMINATION EFFECTS

PIN NAMES

\overline{E}	(Active LOW) Enable Input
D_0, D_1, D_2, D_3	Data Inputs
$\overline{S}_0, \overline{S}_1, \overline{S}_2, \overline{S}_3$	Set (Active LOW) Inputs
\overline{MR}	Master Reset (Active LOW) Input
Q_0, Q_1, Q_2, Q_3	Latch Outputs (Note b)

LOADING

(Note a)	1 U.L.
	1.5 U.L.
	1 U.L.
	1 U.L.
	10 U.L.

NOTES:

- a. 1 Unit Load (U.L.) = 40 μ A HIGH/1.6 mA LOW.
 b. 10 U.L. is the output LOW drive factor and 20 U.L. is the output HIGH drive factor.

LOGIC DIAGRAM

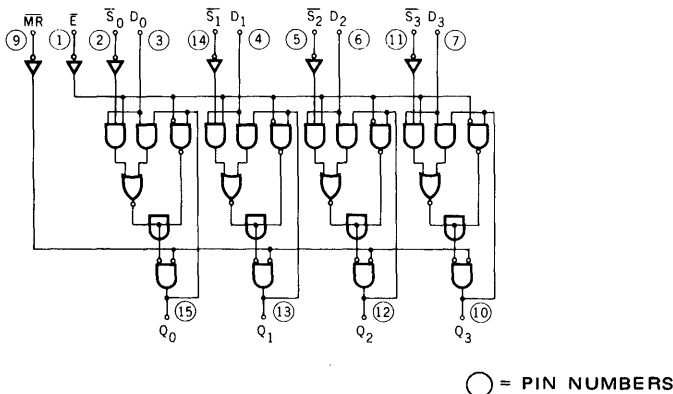

LOGIC SYMBOL

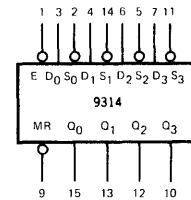

V_{CC} = Pin 16
 G_{nd} = Pin 8

CONNECTION DIAGRAMS DIP (TOP VIEW)

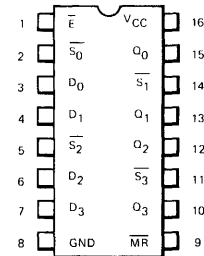

FLATPAK (TOP VIEW)

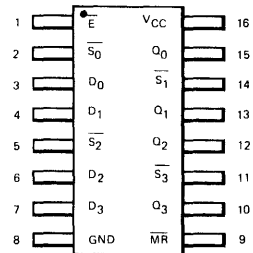

FUNCTIONAL DESCRIPTION

LATCH OPERATION — The 9314 consists of four latches with a common active LOW enable and active LOW master reset. When the common enable goes HIGH, data present in the latches is stored and the state of a latch is no longer affected by the \bar{S} and D inputs. The master reset when activated overrides all other input conditions forcing all latch outputs LOW.

Each of the four latches can be operated in one of two modes:

D TYPE LATCH — For D type operation the \bar{S} input of a latch is held LOW. While the common enable is active the latch output follows the D input. Information present at the latch output is stored in the latch when the enable goes HIGH.

SET/RESET LATCH — During set/reset operation when the common enable is LOW a latch is reset by a LOW on the D input, and can be set by a LOW on the \bar{S} input if the D input is HIGH. If both \bar{S} and D inputs are LOW, the D input will dominate and the latch will be reset. When the enable goes HIGH, the latch remains in the last state prior to the LOW to HIGH transition.

The two modes of operation of the 9314 latches are shown in the Truth Table below.

TRUTH TABLE

$\bar{M}\bar{R}$	\bar{E}	D	\bar{S}	Q_N	OPERATION
H	L	L	L	L	D MODE
H	L	H	L	H	
H	H	X	X	Q_{N-1}	
H	L	L	L	L	R/S MODE
H	L	H	L	H	
H	L	L	H	L	
H	L	H	H	Q_{N-1}	
H	H	H	X	Q_{N-1}	
H	H	X	X	Q_{N-1}	
L	X	X	X	L	RESET

X = Don't Care
 L = LOW Voltage Level
 H = HIGH Voltage Level
 Q_{N-1} = Previous Output State
 Q_N = Present Output State

TYPICAL INPUT AND OUTPUT CHARACTERISTICS

INPUTS

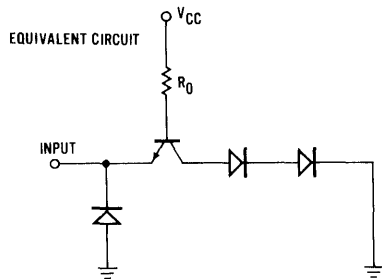

INPUT CURRENT VERSUS INPUT VOLTAGE

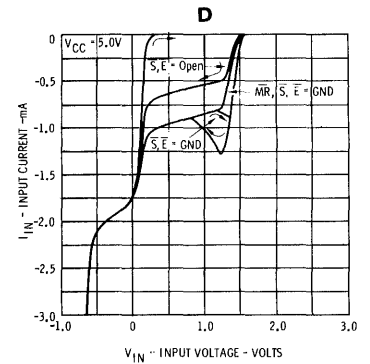
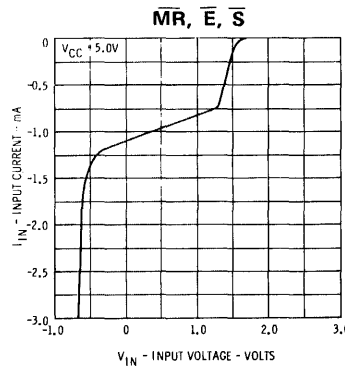

OUTPUTS

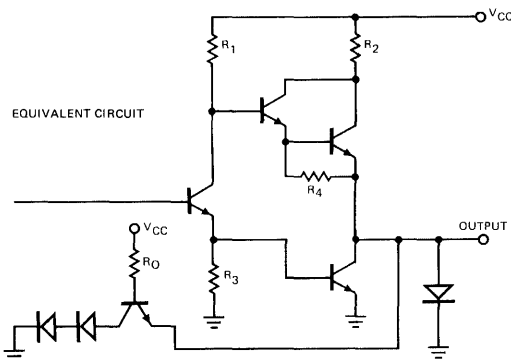

OUTPUT CURRENT VERSUS OUTPUT VOLTAGE

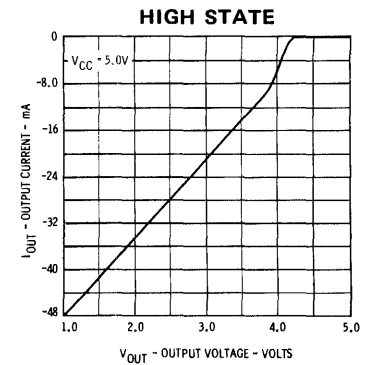
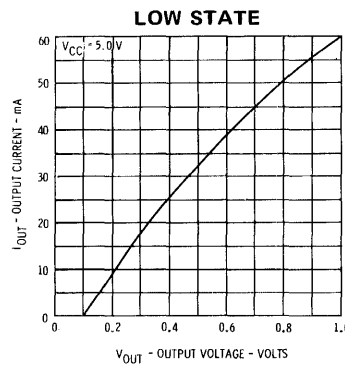

FAIRCHILD TTL/MSI • 9314

ABSOLUTE MAXIMUM RATINGS (above which the useful life may be impaired)

Storage Temperature	-65°C to +150°C
Temperature (Ambient) Under Bias	-55°C to +125°C
V _{CC} Pin Potential to Ground Pin	-0.5 V to +7.0 V
*Input Voltage (dc)	-0.5 V to +5.5 V
*Input Current (dc)	-30 mA to +5.0 mA
Voltage Applied to Outputs (Output HIGH)	-0.5 V to +V _{CC} value
Output Current (dc) (Output LOW)	+30 mA

*Either Input Voltage Limit or Input Current is sufficient to protect the inputs.

GUARANTEED OPERATING RANGES

PART NUMBER	SUPPLY VOLTAGE (V _{CC})			TEMPERATURE
	MIN.	TYP.	MAX.	
9314XM	4.5 V	5.0 V	5.5 V	-55°C to 125°C
9314XC	4.75 V	5.0 V	5.25 V	0°C to 75°C

X = package type; F for Flatpak, D for Ceramic Dip, P for Plastic Dip. See packaging Information Section for packages available on this product.

ELECTRICAL CHARACTERISTICS OVER OPERATING TEMPERATURE RANGE (unless otherwise noted)

SYMBOL	PARAMETER	LIMITS			UNITS	CONDITIONS
		MIN.	TYP. (Note 4)	MAX.		
V _{IH}	Input HIGH Voltage	2.0			Volts	Guaranteed input HIGH Threshold Voltage for all Inputs
V _{IL}	Input LOW Voltage			0.8	Volts	Guaranteed input LOW Threshold Voltage for all Inputs
V _{CD}	Input Clamp Diode Voltage			-1.5	Volts	V _{CC} = MIN., I _{IN} = -12 mA, T _A = 25°C
V _{OH}	Output HIGH Voltage	2.4	3.6		Volts	V _{CC} = MIN., I _{OL} = -800 μA V _{IN} = V _{IH} or V _{IL} per Truth Table
V _{OL}	Output LOW Voltage		0.2	0.4	Volts	V _{CC} = MIN., I _{OL} = 16 mA V _{IN} = V _{IH} or V _{IL} per Truth Table
I _{IH}	Input HIGH Current MR, E, S ₀ , S ₁ , S ₂ , S ₃ D ₀ , D ₁ , D ₂ , D ₃		10 15	40 60	μA	V _{CC} = MAX., V _{IN} = 2.4 V
	Input HIGH Current All Inputs			1.0	mA	V _{CC} = MAX., V _{IN} = 5.5 V
I _{IL}	Input LOW Current MR, E, S ₀ , S ₁ , S ₂ , S ₃ D ₀ , D ₁ , D ₂ , D ₃		-0.96 -1.9	-1.6 -2.7	mA	V _{IN} = 0.4 V, V _{CC} = MAX. V _{IN} = 0.0 V, (Note 6)
	Output Short Circuit Current (I _{OS})	-20	-40	-70	mA	V _{CC} = MAX., V _{OUT} = 0.0 V
I _{CC}	Power Supply Current		35	55	mA	V _{CC} = MAX.

NOTES:

- The actual testing procedures used to guarantee the Electrical Characteristics are contained in a detailed Customer Sample Specification. A copy of this specification can be obtained from Fairchild Digital Product Marketing, Mountain View, California.
- Conditions for testing, not shown in the Table, are chosen to guarantee operation under "worst case" conditions.
- The specified LIMITS represent the "worst case" value for the parameter. Since these "worst case" values normally occur at the temperature and supply voltage extremes, additional noise immunity and guard banding can be achieved by decreasing the allowable system operating ranges.
- Typical limits are at V_{CC} = 5.0 V, 25°C, and maximum loading.
- Not more than one output should be shorted at a time.
- This current is measured at V_{IN} = 0.0 V to insure that no current is being absorbed by the device internally. The maximum value given guarantees that the maximum instantaneous current that can flow out of the input at V_{IN} = 0.4 V is 2.4 mA.

SWITCHING CHARACTERISTICS (T_A = 25°C)

SYMBOL	PARAMETER	LIMITS			UNITS	TEST CONDITIONS
		MIN.	TYP.	MAX.		
t _{PLH}	Turn off Delay Enable to Output		18	24	ns	V _{CC} = 5.0 V C _L = 15 pF
t _{PHL}	Turn on Delay Enable to Output		18	24	ns	
t _{PLH}	Turn off Delay Data to Output		8	12	ns	
t _{PHL}	Turn on Delay Data to Output		18	24	ns	
t _{PHL}	Turn on Delay MR to Output		12	18	ns	
t _{PLH}	Turn off Delay Set to Output		18	24	ns	
						Fig. 2
						Fig. 5
						Fig. 7

SWITCHING SET-UP REQUIREMENTS ($T_A = 25^\circ\text{C}$)

SYMBOL	PARAMETER	LIMITS			UNITS	TEST CONDITIONS
		MIN.	TYP.	MAX.		
$t_s(H)$	Set-up Time HIGH Data to Enable	5.0	0		ns	Fig. 3
$t_h(H)$	Hold Time HIGH Data to Enable	0	-12		ns	
$t_s(L)$	Set-up Time LOW Data to Enable	18	13		ns	
$t_h(L)$	Hold Time LOW Data to Enable	5.0	1.0		ns	
$t_{pw}\overline{E}$	Enable Pulse Width	18	12		ns	Fig. 4
$t_{pw}\overline{MR}$	Master Reset Pulse Width	18	7.0		ns	Fig. 5
t_{rec}	Recovery Time Master Reset to Enable	0	-7		ns	Fig. 6
$t_s(H)$	Set-up Time HIGH Data to Set Input	8.0	0		ns	Fig. 7
$t_h(L)$	Hold Time LOW Data to Set Input	8.0	0		ns	

$V_{CC} = 5.0\text{ V}$

SET UP TIME: t_s is defined as the minimum time required for the logic level to be present at the Data Input prior to the enable transition from LOW to HIGH in order for the latch to recognize and store the new data.

HOLD TIME: t_h is defined as the minimum time following the Enable (E) or Set (S) transition from LOW to HIGH that the logic level must be maintained at the input in order to insure continued recognition. A negative Hold Time indicates that the correct logic level may be released prior to the Enable (E) or Set (S) transition from LOW to HIGH and still be recognized.

RECOVERY TIME: t_{rec} is defined as the minimum time that the Enable must remain LOW after the Master Reset transition from LOW to HIGH in order for the latch to recognize and store HIGH data.

SWITCHING CHARACTERISTICS

All delays are measured with $V_{CC} = 5.0\text{ V}$ applied to Pin 16 and Pin 8 grounded. Outputs under test are loaded with 15 pF (includes jig and probe). Pins not reference are not connected.

t_{PLH}/t_{PHL} (ENABLE TO OUTPUT)

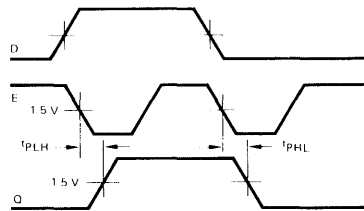

Other Conditions: $\overline{S} = L, \overline{MR} = H$

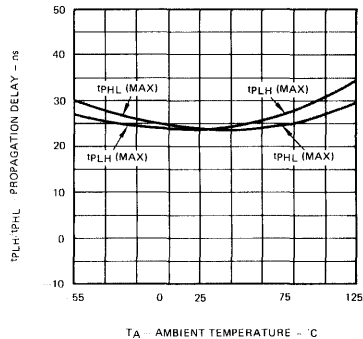
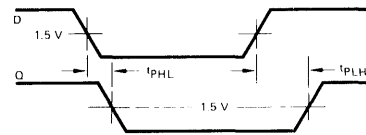

Fig. 1

t_{PLH}/t_{PHL} (DATA TO OUTPUT)



Other Conditions: $\overline{E} = L, \overline{S} = L, \overline{MR} = H$

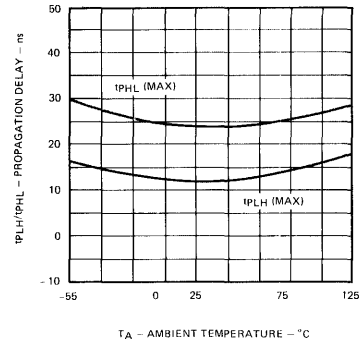
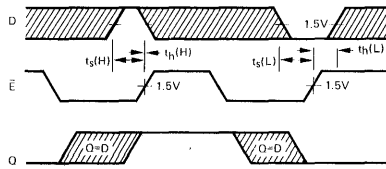

Fig. 2

SWITCHING CHARACTERISTICS

SET-UP TIME (t_s) AND HOLD TIME (t_h) DATA TO ENABLE



OTHER CONDITIONS: $\overline{MR} = H, \overline{S} = L$

The shaded areas indicate when the Data input is permitted to change for predictable output performance.

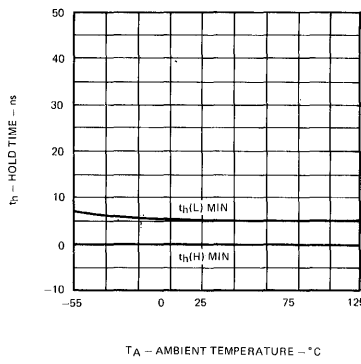
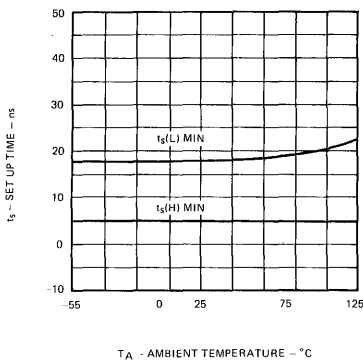
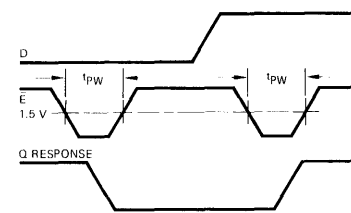

Fig. 3

t_{pw} (MIN. ENABLE PULSE WIDTH)



Other Conditions: $\overline{S} = L, \overline{MR} = H$

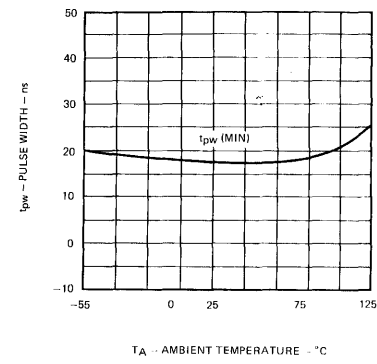
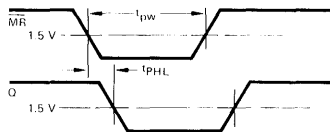

Fig. 4

t_{pw} (MIN. MASTER RESET PULSE WIDTH)
 t_{pHL} (MASTER RESET TO OUTPUT)



Other Conditions: $\overline{S} \text{ \& } \overline{E} = L$

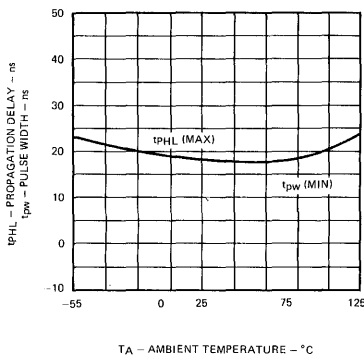
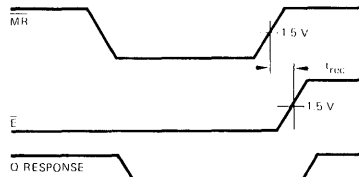

Fig. 5

t_{rec} (MASTER RESET RECOVERY TIME)



Other Conditions: $\overline{S} = L, D = H$

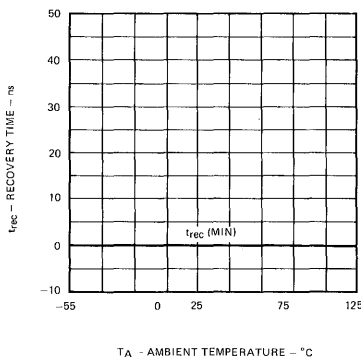
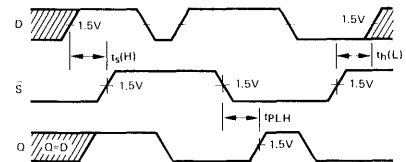

Fig. 6

SET-UP TIME (t_s) AND HOLD TIME (t_h) DATA TO SET INPUT, AND SET TO OUTPUT DELAY.



OTHER CONDITIONS: $\overline{MR} = H, \overline{E} = L$

The shaded area indicates when the Data input is permitted to change for predictable output performance.

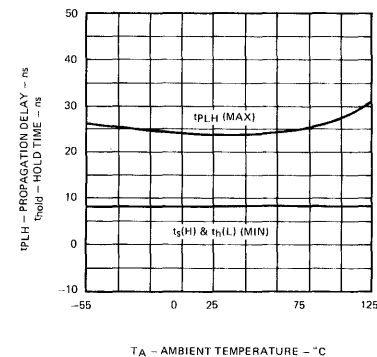

Fig. 7

LPTTL/MSI 93L14

LOW POWER QUAD LATCH

DESCRIPTION – The LPTTL/MSI 93L14 is a multifunctional 4-Bit Latch. The latch is designed for general purpose storage applications in high speed digital systems. The 93L14 uses TTL technology and is compatible with the Fairchild TTL family. All inputs feature diode clamping to reduce negative line transients. All outputs have active pull-up circuitry to provide low impedance in both logic states for good ac noise immunity.

- CAN BE USED AS SINGLE INPUT D LATCHES OR SET/RESET LATCHES
- ACTIVE LEVEL LOW ENABLE GATE INPUT
- OVERRIDING MASTER RESET
- TYPICAL PROPAGATION DELAY OF 68 ns
- TYPICAL POWER DISSIPATION OF 50 mW
- INPUT CLAMP DIODES LIMIT HIGH SPEED TERMINATION EFFECTS
- ALL CERAMIC "HERMETIC" 16-LEAD DUAL IN-LINE AND FLAT PACKAGES
- TTL COMPATIBLE

PIN NAMES

\bar{E}	Enable (Active LOW) Input
D_0, D_1, D_2, D_3	Data Inputs
$\bar{S}_0, \bar{S}_1, \bar{S}_2, \bar{S}_3$	Set (Active LOW) Inputs
MR	Master Reset (Active LOW) Input
Q_0, Q_1, Q_2, Q_3	Latch Outputs

LOADING

	HIGH	LOW
Enable (Active LOW) Input	0.5 U.L.	0.25 U.L.
Data Inputs	0.75 U.L.	0.375 U.L.
Set (Active LOW) Inputs	0.5 U.L.	0.25 U.L.
Master Reset (Active LOW) Input	0.5 U.L.	0.25 U.L.
Latch Outputs	10 U.L.	2.25 U.L.

1 Unit Load (U.L.) = 40 μ A HIGH/1.6 mA LOW.

LOGIC DIAGRAM

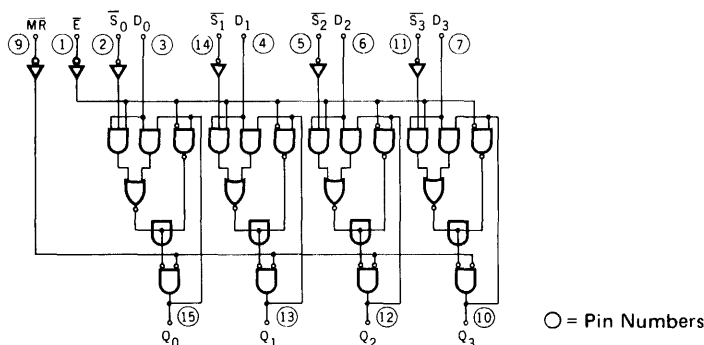

LOGIC SYMBOL

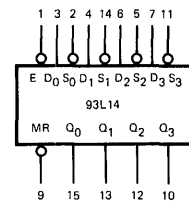

V_{CC} = Pin 16
GND = Pin 8

CONNECTION DIAGRAMS DIP (TOP VIEW)

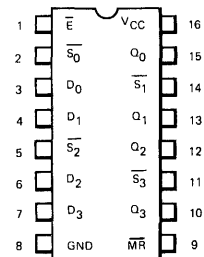

FLATPAK (TOP VIEW)

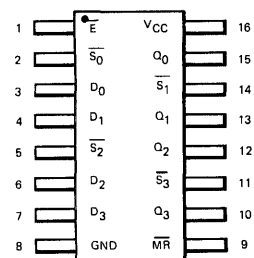

FUNCTIONAL DESCRIPTION

LATCH OPERATION — The 93L14 consists of four latches with a common active LOW enable and active LOW master reset. When the common enable goes HIGH, data present in the latches is stored and the state of a latch is no longer affected by the \bar{S} and D inputs. The master reset when activated overrides all other input conditions forcing all latch outputs LOW.

Each of the four latches can be operated in one of two modes:

D TYPE LATCH — For D type operation the \bar{S} input of a latch is held LOW. While the common enable is active the latch output follows the D input. Information present at the latch output is stored in the latch when the enable goes HIGH.

SET/RESET LATCH — During set/reset operation when the common enable is LOW a latch is reset by a LOW on the D input, and can be set by a LOW on the \bar{S} input if the D input is HIGH. If both \bar{S} and D inputs are LOW, the D input will dominate and the latch will be reset. When the enable goes HIGH, the latch remains in the last state prior to disablement.

The two modes of operation of the 93L14 latches are shown in the Truth Table below.

TRUTH TABLE

\overline{MR}	\overline{E}	D	\overline{S}	Q_n	OPERATION
H	L	L	L	L	D MODE
H	L	H	L	H	
H	H	X	X	Q_{n-1}	
H	L	L	L	L	R/S MODE
H	L	H	L	H	
H	L	L	H	L	
H	L	H	H	Q_{n-1}	
H	H	X	X	Q_{n-1}	
L	X	X	X	L	RESET

X = Don't Care
 L = LOW Voltage Level
 H = HIGH Voltage Level
 Q_{n-1} = Previous Output State
 Q_n = Present Output State

TYPICAL INPUT AND OUTPUT CIRCUITS

INPUTS EQUIVALENT CIRCUIT

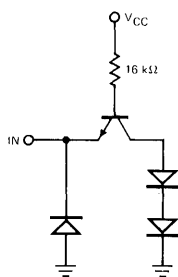

OUTPUTS EQUIVALENT CIRCUIT

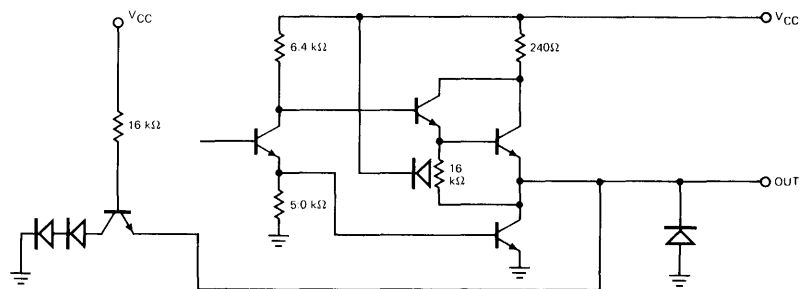

ABSOLUTE MAXIMUM RATINGS (above which the useful life may be impaired)

Storage Temperature	-65° C to +150° C
Temperature (Ambient) Under Bias	-55° C to +125° C
V_{CC} Pin Potential to Ground Pin	-0.5 V to +7.0 V
*Input Voltage (dc)	-0.5 V to +5.5 V
*Input Current (dc)	-30 mA to +5.0 mA
Voltage Applied to Outputs (Output HIGH)	-0.5 V to + V_{CC} value
Output Current (dc) (Output LOW)	+30 mA

*Either Input Voltage limit or Input Current limit is sufficient to protect the inputs.

FAIRCHILD LPTTL/MSI • 93L14

GUARANTEED OPERATING RANGES

PART NUMBER	SUPPLY VOLTAGE (V _{CC})			TEMPERATURE
	MIN.	TYP.	MAX.	
93L14XM	4.5 V	5.0 V	5.5 V	-55°C to 125°C
93L14XC	4.75 V	5.0 V	5.25 V	0°C to 75°C

X = package type; F for Flatpak, D for Ceramic Dip, P for Plastic Dip. See Packaging Information Section for packages available on this product

ELECTRICAL CHARACTERISTICS OVER OPERATING TEMPERATURE RANGE (Unless Otherwise Noted)

SYMBOL	PARAMETER	LIMITS			UNITS	CONDITIONS
		MIN.	TYP. (Note 5)	MAX.		
V _{OH}	Output HIGH Voltage	2.4	3.6		Volts	V _{CC} = MIN., I _{OH} = -0.4 mA V _{IN} = V _{IH} or V _{IL} per Truth Table
V _{OL}	Output LOW Voltage		0.15	0.3	Volts	V _{CC} = MIN., I _{OL} = 3.6 mA V _{IN} = V _{IH} or V _{IL} per Truth Table
V _{IH}	Input HIGH Voltage	2.0			Volts	Guaranteed Input HIGH Threshold Voltage for All Inputs
V _{IL}	Input LOW Voltage			0.7	Volts	Guaranteed Input LOW Threshold Voltage for All Inputs
I _{IL}	Input LOW Current S, E & MR		-0.25	-0.4	mA	V _{CC} = MAX., V _{IN} = 0.3 V
	Input LOW Current D Inputs		-0.38	-0.64	mA	V _{CC} = MAX., V _{IN} = 0.0 V (See Note 4)
I _{IH}	Input HIGH Current S, E & MR		2.0	20	μA	V _{CC} = MAX., V _{IN} = 2.4 V
	D Inputs		3.0	30		
	Input HIGH Current			1.0	mA	V _{CC} = MAX., V _{IN} = 5.5 V
I _{SC} (Note 6)	Output Short Circuit Current	-10	-22	-40	mA	V _{CC} = MAX., V _{OUT} = 0.0 V
I _{CC}	Power Supply Current		10	16.5	mA	V _{CC} = MAX., All Outputs LOW, Inputs Disabled

NOTES:

- (1) The actual testing procedures used to guarantee the Electrical Characteristics are contained in a detailed Customer Sample Specification. A copy of this specification can be obtained from Fairchild Digital Product Marketing, Mountain View, California.
- (2) Conditions for testing, not shown in the Table, are chosen to guarantee operation under "worst case" conditions.
- (3) The specified LIMITS represent the "worst case" value for the parameter. Since these "worst case" values normally occur at the temperature and supply voltage extremes, additional noise immunity and guard banding can be achieved by decreasing the allowable system operating ranges.
- (4) This current is measured at V_{IN} = 0.0 V to insure that no current is being absorbed by the device internally. The maximum value given guarantees that the maximum instantaneous current that can flow out of the input at V_{IN} = 0.3 V is 0.6 mA.
- (5) Typical limits are at V_{CC} = 5.0 V, 25°C, and max. loading.
- (6) Not more than one output should be shorted at a time.

SWITCHING CHARACTERISTICS (T_A = 25°C)

SYMBOL	PARAMETER	LIMITS			UNITS	TEST CONDITIONS
		MIN.	TYP.	MAX.		
t _{PLH}	Turn off Delay Enable to Output		46	80	ns	V _{CC} = 5.0 V C _L = 15 pF
t _{PHL}	Turn off Delay Enable to Output		51	80	ns	
t _{PLH}	Turn off Delay Data to Output		24	40	ns	
t _{PHL}	Turn on Delay Data to Output		45	70	ns	
t _{PHL}	Turn on Delay MR to Output		28	55	ns	
t _{PLH}	Turn off Delay Set to Output		35	60	ns	

SWITCHING SET-UP REQUIREMENTS ($T_A = 25^\circ\text{C}$)

SYMBOL	PARAMETER	LIMITS			UNITS	TEST CONDITIONS		
		MIN.	TYP.	MAX.				
$t_s(H)$	Set-up Time HIGH Data to Enable	15	10		ns	Fig. 3	$V_{CC} = 5.0\text{ V}$	
$t_h(H)$	Hold Time HIGH Data to Enable	-10	-20		ns			
$t_s(L)$	Set-up Time LOW Data to Enable	30	20		ns			
$t_h(L)$	Hold Time LOW Data to Enable	0	-10		ns			
t_{pwE}	Enable Pulse Width	50	30		ns			Fig. 4
t_{pwMR}	Master Reset Pulse Width	45	25		ns			Fig. 5
t_{rec}	Recovery Time Master Reset to Enable	-20	-40		ns			Fig. 6
$t_s(H)$	Set-up Time HIGH Data to Set Input	15	10		ns	Fig. 7		
$t_h(L)$	Hold Time LOW Data to Set Input	0	-4		ns			

SET UP TIME: t_s is defined as the minimum time required for the logic level to be present at the Data Input prior to the enable transition from LOW to HIGH in order for the latch to recognize and store the new data.

HOLD TIME: t_h is defined as the minimum time following the Enable (\bar{E}) or Set (\bar{S}) transition from LOW to HIGH that the logic level must be maintained at the input in order to insure continued recognition. A negative Hold Time indicates that the correct logic level may be released prior to the Enable (\bar{E}) or Set (\bar{S}) transition from LOW to HIGH and still be recognized.

RECOVERY TIME: t_{rec} is defined as the minimum time that the Enable must remain LOW after the Master Reset transition from LOW to HIGH in order for the latch to recognize and store HIGH data. A negative Recovery Time indicates that the Enable may go HIGH prior to the Master Reset transition from LOW to HIGH and still retain HIGH data.

TYPICAL SWITCHING CHARACTERISTICS

All delays are measured with $V_{CC} = 5.0\text{ V}$ applied to Pin 16 and Pin 8 grounded. Outputs under test are loaded with 15 pF (includes jig and probe). Pins not reference are not connected.

t_{PLH}/t_{PHL} (ENABLE TO OUTPUT)

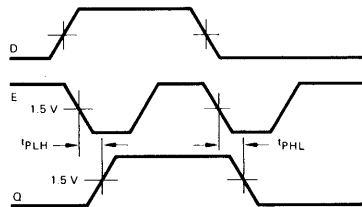

Other Conditions: $\bar{S} = L, \bar{MR} = H$

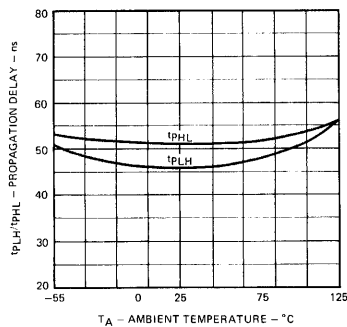
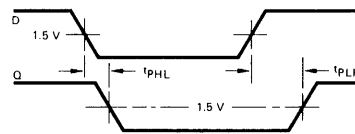

Fig. 1.

t_{PLH}/t_{PHL} (DATA TO OUTPUT)



Other Conditions: $\bar{E} = L, \bar{S} = L, \bar{MR} = H$

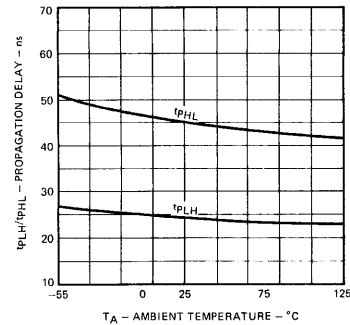
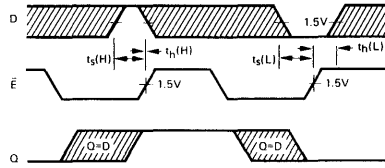

Fig. 2.

SWITCHING CHARACTERISTICS

SET-UP TIME (t_s) AND HOLD TIME (t_h) DATA TO ENABLE



OTHER CONDITIONS: $\overline{MR} = H, \overline{S} = L$

The shaded areas indicate when the Data input is permitted to change for predictable output performance.

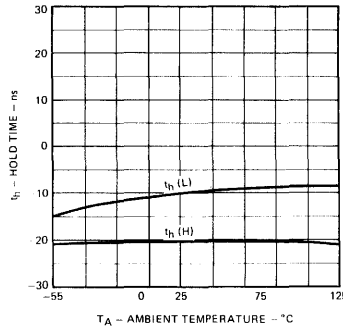
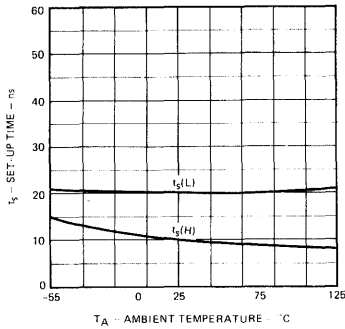
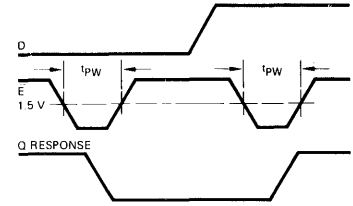

Fig. 3

t_{pw} (MIN. ENABLE PULSE WIDTH)



Other Conditions: $\overline{S} = L, \overline{MR} = H$

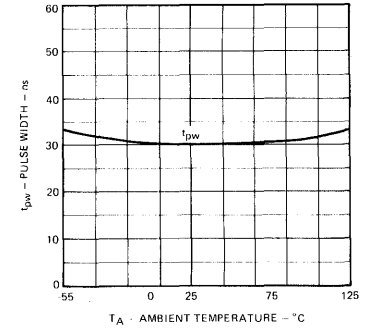
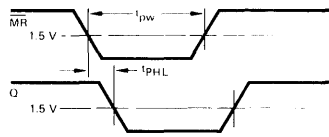

Fig. 4

t_{pw} (MIN. MASTER RESET PULSE WIDTH)
 t_{PHL} (MASTER RESET TO OUTPUT)



Other Conditions: $\overline{S} \text{ \& } \overline{E} = L$

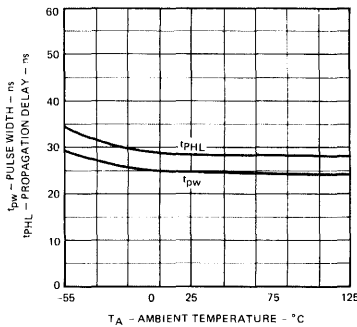
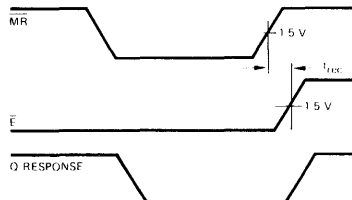

Fig. 5

t_{rec} (MASTER RESET RECOVERY TIME)



Other Conditions: $\overline{S} = L, D = H$

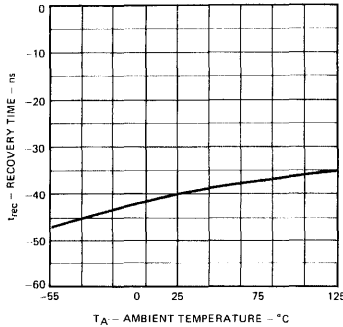
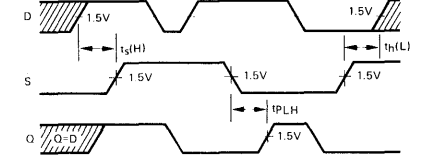

Fig. 6

SET-UP TIME (t_s) AND HOLD TIME (t_h) DATA TO SET INPUT, AND SET TO OUTPUT DELAY.



OTHER CONDITIONS: $\overline{MR} = H, \overline{E} = L$
The shaded area indicates when the Data input is permitted to change for predictable output performance.

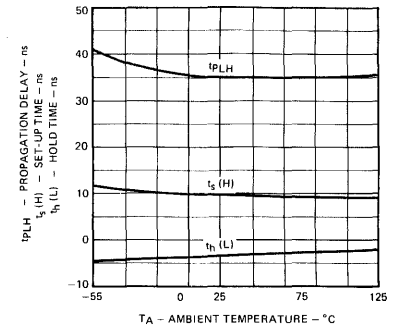

Fig. 7

TTL/MSI 9315 (7441)

1-OF-10 DECODER/DRIVER

DESCRIPTION – The TTL/MSI 9315 accepts 1-2-4-8 binary coded decimal inputs and provides ten mutually exclusive outputs to directly control the ionizing potentials of many gas filled cold cathode indicator tubes. The 9315 is similar in operation to the $C\mu L9960$, but the 9315 can be driven from any TTL or DTL product.

- **STABLE HIGH VOLTAGE OUTPUT CHARACTERISTICS**
- **DIRECT DISPLAY DRIVE CAPABILITY**
- **BCD ACTIVE LEVEL HIGH INPUTS**
- **BLANKING TEST MODE**
- **-55°C TO +125°C TEMPERATURE CAPABILITY**

ABSOLUTE MAXIMUM RATINGS (above which the useful life may be impaired)

Storage Temperature	-65°C to +150°C
Temperature (Ambient) Under Bias	-55°C to +125°C
V _{CC} Pin Potential to Ground Pin	-0.5 V to +7 V
Input Voltage (dc) (See Note 1)	-1.5 V to +5.5 V
Input Current (dc) (See Note 1)	-10 mA to +1.0 mA
Current into output when output is LOW	10 mA
Current into each output when output is HIGH (See Note 2)	+1.5 mA

Note 1: Either Input Voltage limit or Input Current limit is sufficient to protect the inputs.

Note 2: Total current through all 10 outputs in the HIGH state shall not exceed 2.0 mA.

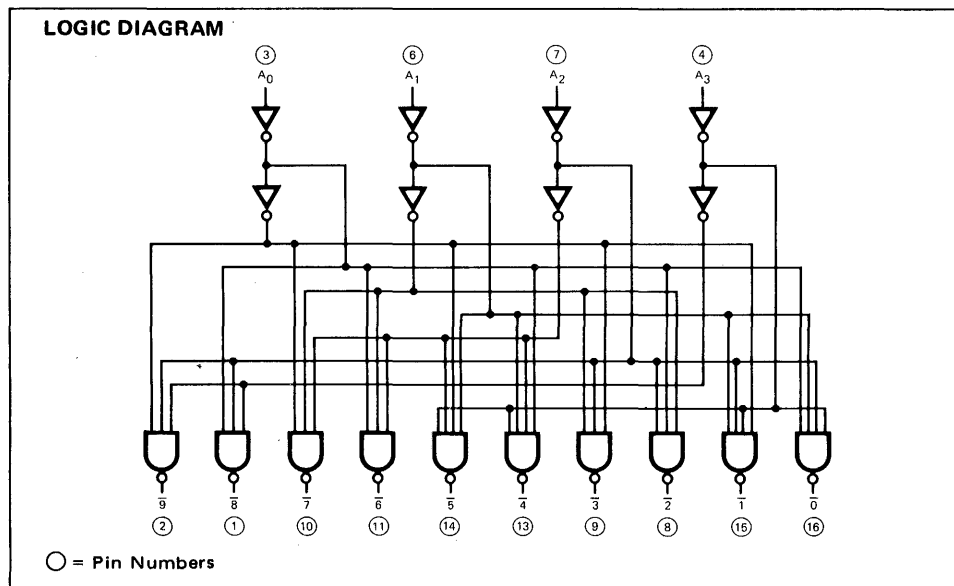
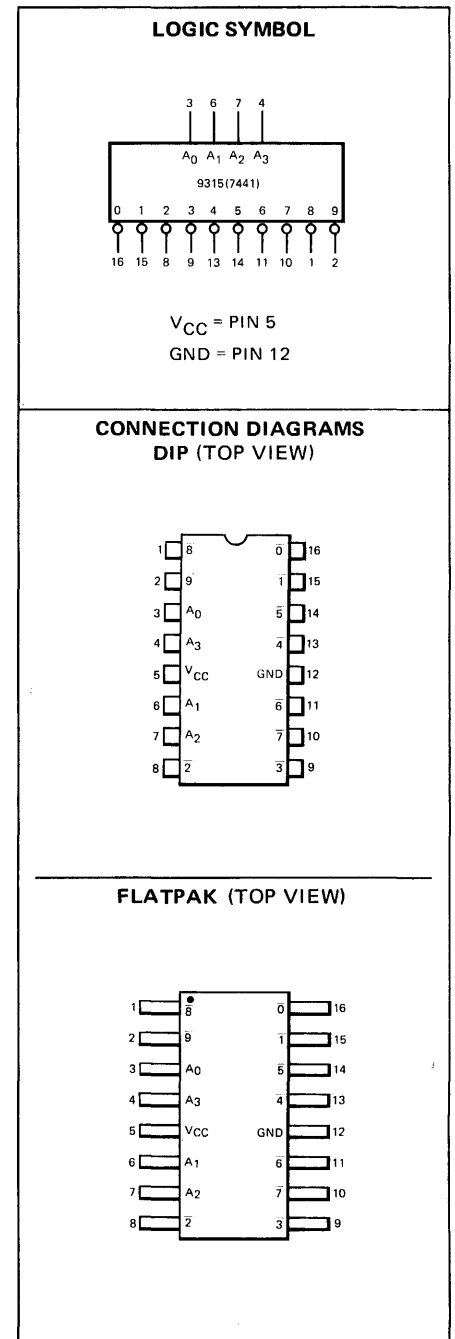

FAIRCHILD TTL/MSI • 9315 (7441)

FUNCTIONAL DESCRIPTION — The one-of-ten decoder/driver accepts BCD inputs from all TTL circuits and produces the correct output selection to directly drive gas filled cold cathode indicator tubes. The outputs are selected as shown in the Truth Table. It is capable of driving all known available cold cathode indicator tubes having 7 mA or less cathode current.

Unused input codes 12 and 13 cause all the outputs to remain HIGH, no cathode will be selected. This results in the indicator tube being blanked. Using this feature for blanking may cause a slight glow to appear in the tube.

TRUTH TABLE

	A ₀	A ₁	A ₂	A ₃	0	1	2	3	4	5	6	7	8	9
0	L	L	L	L	L	H	H	H	H	H	H	H	H	H
1	H	L	L	L	H	L	H	H	H	H	H	H	H	H
2	L	H	L	L	H	H	L	H	H	H	H	H	H	H
3	H	H	L	L	H	H	H	L	H	H	H	H	H	H
4	L	L	H	L	H	H	H	H	L	H	H	H	H	H
5	H	L	H	L	H	H	H	H	H	L	H	H	H	H
6	L	H	H	L	H	H	H	H	H	H	L	H	H	H
7	H	H	H	L	H	H	H	H	H	H	H	L	H	H
8	L	L	L	H	H	H	H	H	H	H	H	H	L	H
9	H	L	L	H	H	H	H	H	H	H	H	H	H	L
10	L	H	L	H	H	H	L	H	H	H	H	H	L	H
11	H	H	L	H	H	H	L	H	H	H	H	H	H	L
12	L	L	H	H	H	H	H	H	H	H	H	H	H	H
13	H	L	H	H	H	H	H	H	H	H	H	H	H	H
14	L	H	H	H	H	H	H	H	H	H	L	H	H	H
15	H	H	H	H	H	H	H	H	H	H	H	L	H	H

H = HIGH voltage level
L = LOW voltage level

LOADING RULES

INPUTS	LOADING
All Inputs	1 U.L.

TTL INPUT LOAD

GRADE	INPUTS	LOADING
IND	All Inputs	1/9.4
MIL	All Inputs	2/9.4

OUTPUTS are designed to drive gas filled cold Cathode Indicator tubes

1 U.L. = 1 DTL Unit Load
1 U.L. is defined by the entries I_{IH} and I_{IL} in the table on following page.

TYPICAL INPUT AND OUTPUT CHARACTERISTICS

EQUIVALENT INPUT CIRCUIT

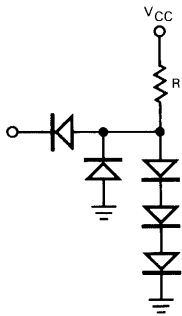

INPUT CURRENT VERSUS INPUT VOLTAGE
A₀, A₁, A₂, A₃ INPUTS

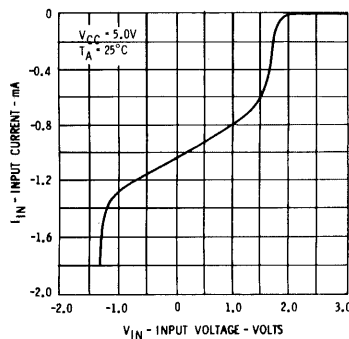

EQUIVALENT OUTPUT CIRCUIT

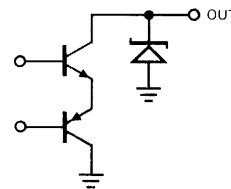

OUTPUT CURRENT VERSUS OUTPUT VOLTAGE
(OUTPUT HIGH)

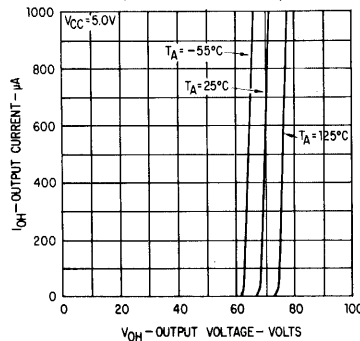

OUTPUT CURRENT VERSUS OUTPUT VOLTAGE
(OUTPUT LOW)

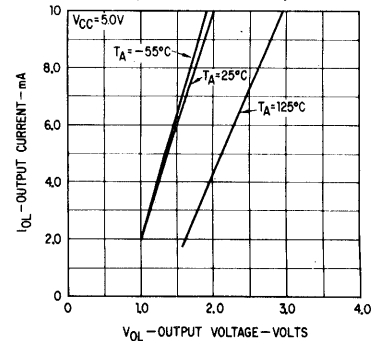

FAIRCHILD TTL/MSI • 9315 (7441)

ELECTRICAL CHARACTERISTICS ($T_A = -55^\circ\text{C}$ to $+125^\circ\text{C}$, $V_{CC} = 5.0\text{ V} \pm 10\%$) (Part No. 9315XM, see note)

SYMBOL	PARAMETER	LIMITS						UNITS	CONDITIONS	
		-55°C		$+25^\circ\text{C}$		$+125^\circ\text{C}$				
		MIN.	MAX.	MIN.	TYP.	MAX.	MIN.	MAX.		
V_{OH}	Output HIGH Voltage	61		70	75		70		Volts	$V_{CC} = 5.5\text{ V}$, Force 2.0 mA into HIGH Output
I_{OH}	Output HIGH Leakage Current					20		50	μA	$V_{CC} = 5.5\text{ V}$, $V_{OUT} = 55\text{ V}$ Inputs at Threshold Voltages ($V_{IL} = \text{Gnd}$, $V_{IH} = 4.5\text{ V}$) as per Truth Table
V_{OL}	Output LOW Voltage		3.0			2.5		3.7	Volts	$V_{CC} = 4.5\text{ V}$, $I_{OL} = 7.0\text{ mA}$ Inputs at Threshold Voltages (V_{IL} or V_{IH}) as per Truth Table
V_{IH}	Input HIGH Voltage	2.1		1.9				1.7	Volts	Guaranteed Input HIGH Threshold Voltage for All Inputs
V_{IL}	Input LOW Voltage		1.4			1.1		0.8	Volts	Guaranteed Input LOW Threshold Voltage for All Inputs
I_{IL}	Input LOW Current		-1.5		-1.3	-1.5		-1.5	mA	$V_{CC} = 5.5\text{ V}$, $V_{IN} = 0.4\text{ V}$ Other Inputs Open
I_{IH}	Input HIGH Current				0.02	2.0		5.0	μA	$V_{CC} = 5.5\text{ V}$, $V_{IN} = 4.5\text{ V}$ Other Inputs Open
I_{CC}	Supply Current		29			29		29	mA	$V_{CC} = 5.0\text{ V}$, No Connection to Input or Output Pins

ELECTRICAL CHARACTERISTICS ($T_A = 0^\circ\text{C}$ to $+75^\circ\text{C}$, $V_{CC} = 5.0\text{ V} \pm 5\%$) (Part No. 9315XC, see note)

SYMBOL	PARAMETER	LIMITS						UNITS	CONDITIONS	
		0°C		$+25^\circ\text{C}$		$+75^\circ\text{C}$				
		MIN.	MAX.	MIN.	TYP.	MAX.	MIN.	MAX.		
V_{OH}	Output HIGH Voltage	67		70	75		70		Volts	$V_{CC} = 5.25\text{ V}$, Force 2.0 mA into HIGH Output
I_{OH}	Output HIGH Leakage Current					40		50	μA	$V_{CC} = 5.25\text{ V}$, $V_{OUT} = 55\text{ V}$ Inputs at Threshold Voltages ($V_{IL} = \text{Gnd}$, $V_{IH} = 4.5\text{ V}$) as per Truth Table
V_{OL}	Output LOW Voltage		3.2			3.0		3.6	Volts	$V_{CC} = 4.75\text{ V}$, $I_{OL} = 7.0\text{ mA}$ Inputs at Threshold Voltages (V_{IL} or V_{IH}) as per Truth Table
V_{IH}	Input HIGH Voltage	2.0		2.0				2.0	Volts	Guaranteed Input HIGH Threshold Voltage for All Inputs
V_{IL}	Input LOW Voltage		0.85			0.85		0.85	Volts	Guaranteed Input LOW Threshold Voltage for All Inputs
I_{IL}	Input LOW Current		-1.5			-1.5		-1.5	mA	$V_{CC} = 5.25\text{ V}$, $V_{IN} = 0.45\text{ V}$ Other Inputs Open
I_{IH}	Input HIGH Current					5.0		10	μA	$V_{CC} = 5.25\text{ V}$, $V_{IN} = 4.5\text{ V}$ Other Inputs Open
I_{CC}	Supply Current		31			31		31	mA	$V_{CC} = 5.0\text{ V}$, No Connection to Input or Output Pins

NOTE:

X = package type; F for Flatpak, D for Ceramic Dip, P for Plastic Dip. See Packaging Information Section for packages available on this product.

TTL/MSI 9317B • 9317C

SEVEN SEGMENT DECODER/DRIVER

DESCRIPTION — The 9317 is a TTL/MSI Seven Segment Decoder/Driver designed to accept four inputs in 8421 BCD code and provide the appropriate outputs to drive a seven segment numerical display. The decoder can be used to directly drive seven segment incandescent lamp displays and light emitting diode indicators (or indirectly drive neon, electro-luminescent, numeric displays). The 9317 is compatible with all members of the Fairchild TTL family.

The 9317 is available in two output current and latch voltage versions, the 9317B and C.

- TFL COMPATIBLE
- AUTOMATIC RIPPLE BLANKING FOR SUPPRESSION OF LEADING EDGE ZEROS AND/OR TRAILING EDGE ZEROS
- LAMP INTENSITY MODULATION CAPABILITY
- LAMP TEST FACILITY
- BLANKING INPUT
- ACTIVE LOW OUTPUTS
- ALL CERAMIC "HERMETIC" 16-LEAD DUAL IN-LINE PACKAGE
- DRIVE LAMPS DIRECTLY
- CODES IN EXCESS OF BINARY 9 DISABLE OUTPUTS
- ENHANCED RELIABILITY WITH UNIQUE NUMERIC ONE DISPLAY POSITION

PIN NAMES

A_0, A_1, A_2, A_3	Address Inputs
\overline{LT}	Lamp Test (Active LOW) Input
\overline{RBI}	Ripple Blanking (Active LOW) Input
\overline{RBO}	Ripple Blanking (Active LOW) Output
$\overline{a}, \overline{b}, \overline{c}, \overline{d}, \overline{e}, \overline{f}, \overline{g}$	(Active LOW) Outputs

1 Unit Load (U.L.) = 40 μ A HIGH/1.6 mA LOW

LOADING

HIGH	LOW
1.0 U.L.	1.0 U.L.
5.0 U.L.	4.0 U.L.
1.0 U.L.	0.5 U.L.
1.5 U.L.	1.5 U.L.

See Options

OPTIONS

PARAMETER	9317B	9317C
Latch Voltage	20 Volts	30 Volts
Output Current (Pins 9 through 15)	40 mA	20 mA

LOGIC DIAGRAM

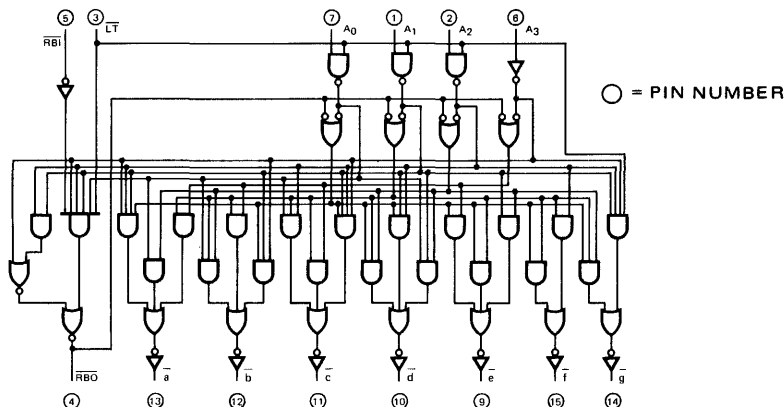

LOGIC SYMBOL

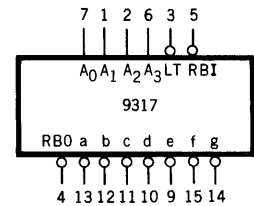

V_{CC} = Pin 16
GND = Pin 8

CONNECTION DIAGRAMS DIP (TOP VIEW)

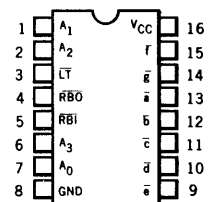

FLATPAK (TOP VIEW)

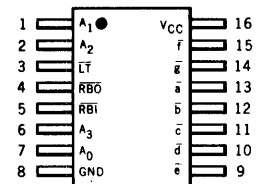

FUNCTIONAL DESCRIPTION — The 9317 seven segment decoder/driver accepts a 4-bit BCD 8421 code input and produces the appropriate outputs for selection of segments in a seven segment matrix display used for representing the decimal numbers 0–9. The seven outputs ($\bar{a}, \bar{b}, \bar{c}, \bar{d}, \bar{e}, \bar{f}, \bar{g}$) of the decoder select the corresponding segments in the matrix shown in Figure 1. The numeric designations chosen to represent the decimal numbers are shown in Figure 3. Code configurations in excess of binary nine disable the outputs.

The decoder has active LOW outputs so that it may be used directly to drive incandescent displays or light emitting diode indicators.

The device has provision for automatic blanking of the leading and/or trailing edge zeros in a multidigit decimal number, resulting in an easily readable decimal display conforming to normal writing practice. In an eight digit mixed interger fraction decimal representation, using the automatic blanking capability, 0060.0300 would be displayed as 60.03. Leading edge zero suppression is obtained by connecting the Ripple Blanking Output (\bar{RBO}) of a decoder to the Ripple Blanking Input (\bar{RBI}) of the next lower stage device. The most significant decoder stage should have the \bar{RBI} input grounded; and, since suppression of the least significant integer zero in a number is not usually desired, the \bar{RBI} input of this decoder stage should be left open. A similar procedure for the fractional part of a display will provide automatic suppression of trailing edge zeros.

The decoder has an active LOW input Lamp Test which overrides all other input combinations and allows checking on possible display malfunctions. The \bar{RBO} terminal of the decoder can be OR-tied with a modulating signal via an isolating buffer to achieve pulse duration intensity modulation. A suitable signal can be generated for this purpose by forming a variable frequency multivibrator with a cross coupled pair of TTL or DTL gates.

TRUTH TABLE

\bar{LT}	\bar{RBI}	A ₀	A ₁	A ₂	A ₃	\bar{a}	\bar{b}	\bar{c}	\bar{d}	\bar{e}	\bar{f}	\bar{g}	\bar{RBO}	DECIMAL OR FUNCTION
L	X	X	X	X	X	L	L	L	L	L	L	L	H	0
H	L	L	L	L	L	H	H	H	H	H	H	H	L	1
H	H	L	L	L	L	L	L	L	L	L	L	H	H	2
H	X	H	L	L	L	L	L	L	L	L	L	H	H	3
H	L	L	H	L	L	L	L	L	L	L	L	H	H	4
H	L	L	L	H	L	L	L	L	L	L	L	H	H	5
H	L	H	H	L	L	L	L	L	L	L	L	H	H	6
H	H	H	L	L	L	L	L	L	L	L	L	H	H	7
H	L	L	L	H	L	L	L	L	L	L	L	H	H	8
H	L	L	L	L	H	L	L	L	L	L	L	H	H	9
H	L	H	L	H	H	H	H	H	H	H	H	L	L	10
H	H	L	L	H	H	H	H	H	H	H	H	L	L	11
H	L	L	H	H	H	H	H	H	H	H	H	L	L	12
H	L	H	H	H	H	H	H	H	H	H	H	L	L	13
H	L	H	H	H	H	H	H	H	H	H	H	L	L	14
H	X	H	H	H	H	H	H	H	H	H	H	L	L	15

H = HIGH Voltage Level
L = LOW Voltage Level
X = Don't Care Condition

Fig. 1
SEGMENT DESIGNATION

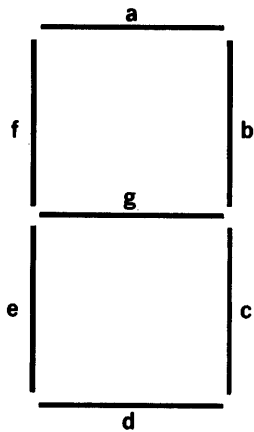

Fig. 2
SEVEN SEGMENT DECODER DRIVING INCANDESCENT LAMP DISPLAY

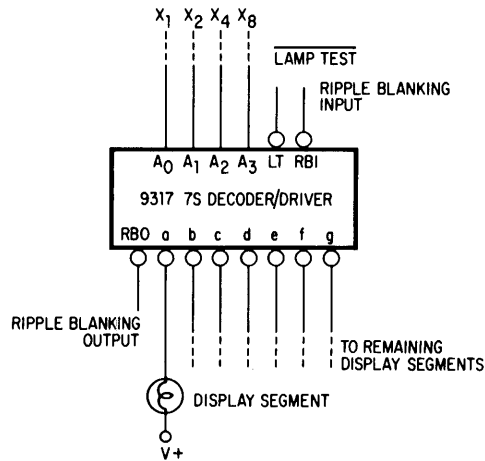
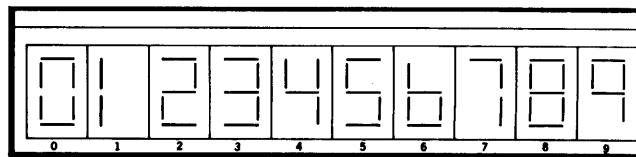

Fig. 3
NUMERICAL DESIGNATIONS



ABSOLUTE MAXIMUM RATINGS (above which the useful life may be impaired)

Storage Temperature	-65° C to +150° C
Temperature (Ambient) Under Bias	-55° C to +125° C
V _{CC} Pin Potential to Ground Pin	-0.5 V to +7.0 V
Voltage Applied to Outputs for HIGH Output State	-0.5 V to +30° V
Input Voltage (dc)	-0.5 V to +5.5 V
Current Into Outputs	80 mA
Power Dissipation per Output	9317B 50 mW
	9317C 30 mW

TTL/MSI 9317B • 9317C

ELECTRICAL CHARACTERISTICS ($T_A = -55^\circ\text{C}$ to $+125^\circ\text{C}$, $V_{CC} = 5.0\text{ V} \pm 10\%$) (Part No. 9317BXM • 9317CXM)*

SYMBOL	PARAMETER	LIMITS					UNITS	CONDITIONS		
		-55°C		$+25^\circ\text{C}$		$+125^\circ\text{C}$				
		MIN.	MAX.	MIN.	TYP.	MAX.	MIN.	MAX.		
V_{OH}	Output HIGH Voltage on $\overline{R\overline{B}O}$ Only	3.0		3.0	4.0		3.0		Volts	$V_{CC} = 4.5\text{ V}$, $I_{OH} = -70\ \mu\text{A}$ Pin 5 = V_{IH} , Pins 1, 2, 6, 7 = 0 V
I_{CEX}	Output HIGH Leakage Current			100	200		250		μA	$V_{CC} = 5.5\text{ V}$, $V_{CEX} = 30\text{ V}$ (CXM), 20 V (BXM) Inputs at V_{IH} or V_{IL} per Truth Table
V_{OL}	Output LOW Voltage on $\overline{R\overline{B}O}$ Only	0.4		0.21	0.4		0.4		Volts	Inputs at V_{IH} or V_{IL} per Truth Table
		0.4		0.21	0.4		0.4		Volts	
V_{OL}	Output LOW Voltage	9317BXM	0.8		0.50	0.8		0.8	Volts	$V_{CC} = 4.5\text{ V}$, $I_{OL} = 40\text{ mA}$ Pin 3 = 0 V
		9317CXM	0.4		0.21	0.4		0.4	Volts	$V_{CC} = 4.5\text{ V}$, $I_{OL} = 20\text{ mA}$ Pin 3 = 0 V
V_{LATCH}	Output Latch Voltage	9317BXM	20		20		20		Volts	$V_{CC} = 5.0\text{ V}$, $I_{OUT} = 10\text{ mA}$
		9317CXM	30		30		30		Volts	Inputs = Open
V_{IH}	Input HIGH Voltage	2.1		1.9			1.7		Volts	Guaranteed Input HIGH Threshold for All Inputs
V_{IL}	Input LOW Voltage		1.4			1.1		0.8	Volts	Guaranteed Input LOW Threshold for All Inputs
I_{IL}	Input LOW Current LT A ₀ , A ₁ , A ₂ , A ₃ $\overline{R\overline{B}I}$		-6.4		-6.4		-6.4		mA	$V_{CC} = 5.5\text{ V}$, $V_{IN} = 0.4\text{ V}$ $V_{IN} = 5.5\text{ V}$ on Other Inputs
			-1.5		-1.5		-1.5		mA	
			-0.75		-0.75		-0.75		mA	
I_{IH}	Input HIGH Current LT $\overline{R\overline{B}I}$, A ₀ , A ₁ , A ₂ , A ₃				200		200		μA	$V_{CC} = 5.5\text{ V}$, $V_{IN} = 2.4\text{ V}$ GND on Other Inputs
					40		40		μA	
t_{PLH}	Turn Off Delay					500			ns	$V_{CC} = 5.0\text{ V}$, See Figure 4
t_{PHL}	Turn On Delay					500			ns	

ELECTRICAL CHARACTERISTICS ($T_A = 0^\circ\text{C}$ to $+75^\circ\text{C}$, $V_{CC} = 5.0\text{ V} \pm 5\%$) (Part No. 9317BXC • 9317CXC)*

SYMBOL	PARAMETER	LIMITS					UNITS	CONDITIONS		
		0°C		$+25^\circ\text{C}$		$+75^\circ\text{C}$				
		MIN.	MAX.	MIN.	TYP.	MAX.	MIN.	MAX.		
V_{OH}	Output HIGH Voltage on $\overline{R\overline{B}O}$ Only	3.0		3.0	4.0		3.0		Volts	$V_{CC} = 4.75\text{ V}$, $I_{OH} = -70\ \mu\text{A}$ Pin 5 = V_{IH} , Pins 1, 2, 6, 7 = 0 V
I_{CEX}	Output HIGH Leakage Current			100	200		250		μA	$V_{CC} = 5.25\text{ V}$, $V_{CEX} = 30\text{ V}$ (CXC), 20 V (BXC) Inputs at V_{IH} or V_{IL} per Truth Table
V_{OL}	Output LOW Voltage on $\overline{R\overline{B}O}$ Only	0.45		0.25	0.45		0.45		Volts	Inputs at V_{IH} or V_{IL} per Truth Table
		0.45		0.25	0.45		0.45		Volts	
V_{OL}	Output LOW Voltage	9317BXC	0.9		0.65	0.9		0.9	Volts	$V_{CC} = 4.75\text{ V}$, $I_{OL} = 40\text{ mA}$ Pin 3 = 0 V
		9317CXC	0.45		0.25	0.45		0.45	Volts	$V_{CC} = 4.75\text{ V}$, $I_{OL} = 20\text{ mA}$ Pin 3 = 0 V
V_{LATCH}	Output Latch Voltage	9317BXC	20		20		20		Volts	$V_{CC} = 5.0\text{ V}$, $I_{OUT} = 10\text{ mA}$
		9317CXC	30		30		30		Volts	Inputs = Open
V_{IH}	Input HIGH Voltage	2.0		2.0			2.0		Volts	Guaranteed Input HIGH Threshold for All Inputs
V_{IL}	Input LOW Voltage		0.85			0.85		0.85	Volts	Guaranteed Input LOW Threshold for All Inputs
I_{IL}	Input LOW Current LT A ₀ , A ₁ , A ₂ , A ₃ $\overline{R\overline{B}I}$		-6.4		-6.4		-6.4		mA	$V_{CC} = 5.25\text{ V}$, $V_{IN} = 0.45\text{ V}$ $V_{IN} = 5.25\text{ V}$ on Other Inputs
			-1.5		-1.5		-1.5		mA	
			-0.75		-0.75		-0.75		mA	
I_{IH}	Input HIGH Current LT $\overline{R\overline{B}I}$, A ₀ , A ₁ , A ₂ , A ₃				200		200		μA	$V_{CC} = 5.25\text{ V}$, $V_{IN} = 2.4\text{ V}$ GND on Other Inputs
					40		40		μA	
t_{PLH}	Turn Off Delay					500			ns	$V_{CC} = 5.0\text{ V}$, See Figure 4
t_{PHL}	Turn On Delay					500			ns	

* X = package type; F for Flatpak, D for Ceramic Dip, P for Plastic Dip. See Packaging Information Section for packages available on this product.

Fig. 4 – SWITCHING CIRCUIT AND WAVEFORMS

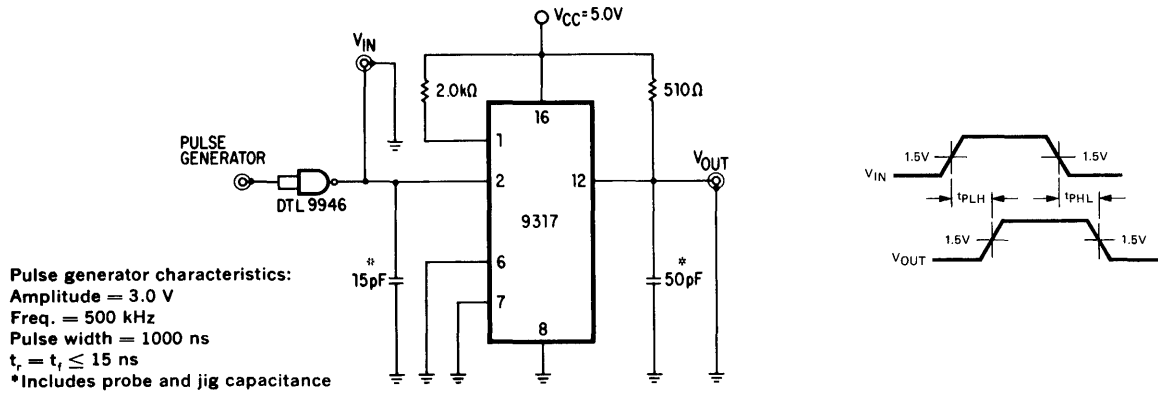

TYPICAL INPUT CHARACTERISTICS

INPUT CURRENT VERSUS INPUT VOLTAGE

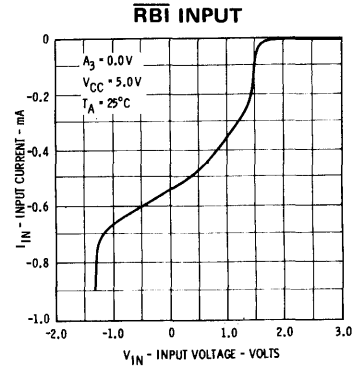
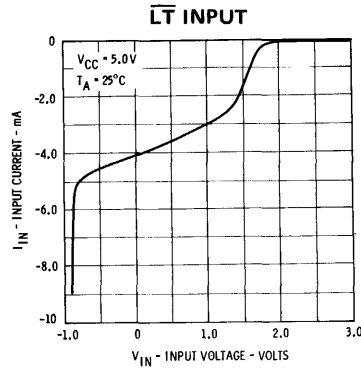
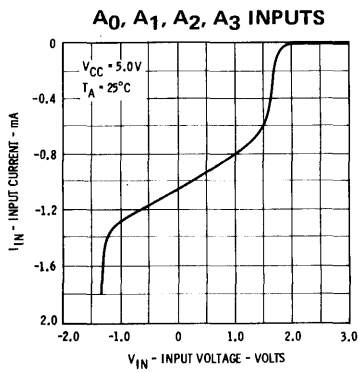

INPUTS
EQUIVALENT CIRCUIT

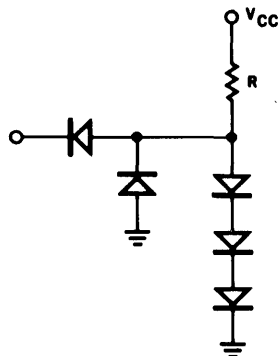

OUTPUT CHARACTERISTICS

OUTPUT CURRENT VERSUS OUTPUT VOLTAGE
9317BXM, 9317BXC

TYPICAL OUTPUT IN HIGH STATE

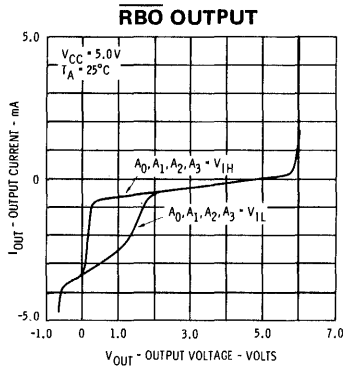
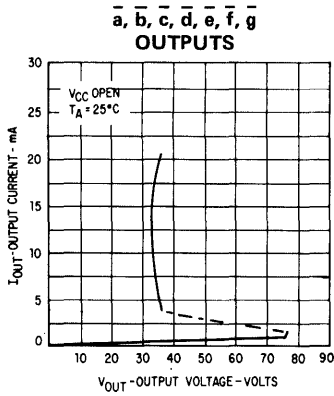

TYPICAL OUTPUT IN LOW STATE

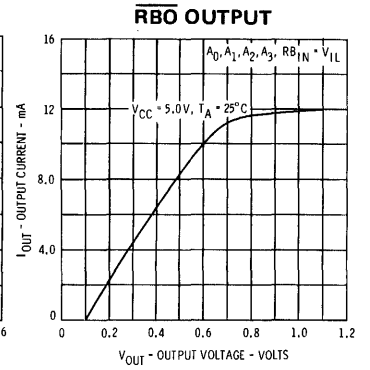
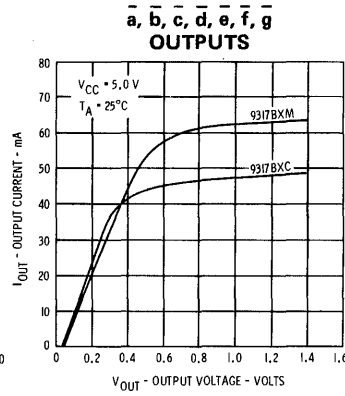

9317CXM, 9317CXC

TYPICAL OUTPUT IN HIGH STATE

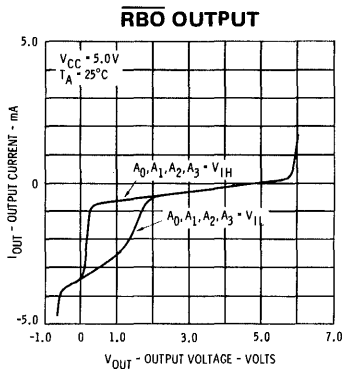
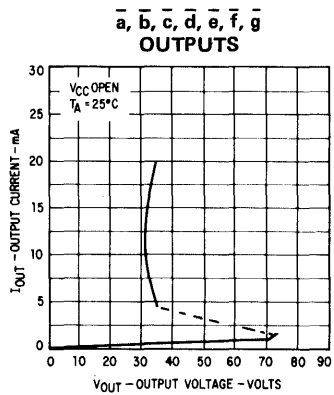

TYPICAL OUTPUT IN LOW STATE

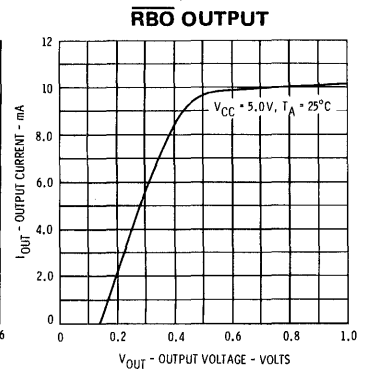
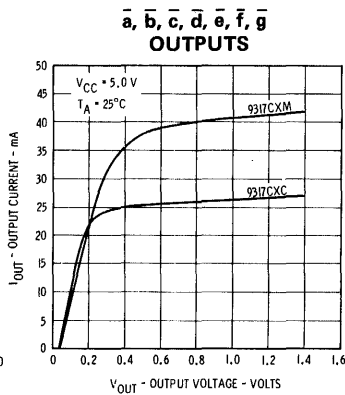

OUTPUTS

EQUIVALENT CIRCUIT (PIN 4)

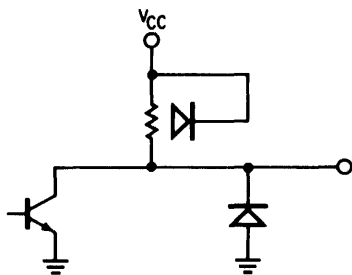

EQUIVALENT CIRCUIT
(Pins 9 thru 15)

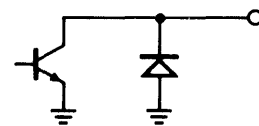

TTL/MSI 9318

EIGHT-INPUT PRIORITY ENCODER

DESCRIPTION — The TTL/MSI 9318 is a Multipurpose Encoder designed to accept eight inputs and produce a binary weighted code of the highest order input. The circuit uses TTL for high speed and high fanout capability, and is compatible with all members of the Fairchild TTL family.

- **MULTI-FUNCTION CAPABILITY**
 - CODE CONVERSIONS
 - MULTI-CHANNEL D/A CONVERTER
 - DECIMAL TO BCD CONVERTER
 - CASCADING FOR PRIORITY ENCODING OF N BITS
- **INPUT ENABLE CAPABILITY**
- **PRIORITY ENCODING — AUTOMATIC SELECTION OF HIGHEST PRIORITY INPUT LINE**
- **OUTPUT ENABLE — ACTIVE LOW WHEN ALL INPUTS HIGH**
- **GROUP SIGNAL OUTPUT — ACTIVE WHEN ANY INPUT IS LOW**
- **TYPICAL POWER DISSIPATION OF 250 mW**
- **INPUT/OUTPUT CHARACTERISTICS PROVIDE EASY INTERFACING WITH FAIRCHILD DTL, LPDTL, TTL, AND MSI FAMILIES**
- **ALL CERAMIC HERMETIC 16-LEAD DUAL IN-LINE PACKAGE**
- **INPUT CLAMP DIODES LIMIT HIGH SPEED TERMINATION EFFECTS**

PIN NAMES

$\bar{0}$	Priority (Active LOW) Input
$\bar{1}$ to $\bar{7}$	Priority (Active LOW) Inputs
\bar{EI}	Enable (Active LOW) Input
\bar{EO}	Enable (Active LOW) Output
\bar{GS}	Group Select (Active LOW) Output
$\bar{A}_0, \bar{A}_1, \bar{A}_2$	Address (Active LOW) Outputs

LOADING

(Note a)
1 U.L.
2 U.L.
2 U.L.
10 U.L.*
10 U.L.*
10 U.L.*

NOTES:

- a. 1 Unit Load (U.L.) = 40 μ A HIGH/1.6 mA LOW
- b. 10 U.L. is the output LOW drive factor and 20 U.L. is the output HIGH drive factor.

LOGIC SYMBOL

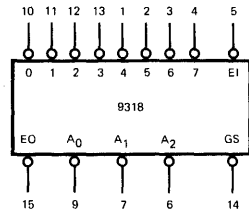

V_{CC} = Pin 16
GND = Pin 8

CONNECTION DIAGRAMS
DIP (TOP VIEW)

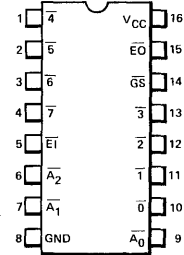

FLATPAK (TOP VIEW)

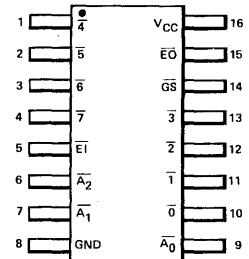

LOGIC DIAGRAM

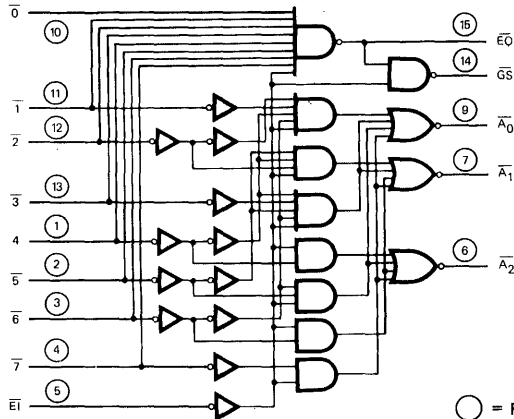

FUNCTIONAL DESCRIPTION — The 9318 8-input priority encoder accepts data from eight active LOW inputs and provides a binary representation on the three active LOW outputs. A priority is assigned to each input so that when two or more inputs are simultaneously active, the input with the highest priority is represented on the output, with input line 7 having the highest priority.

A HIGH on the Input Enable ($\overline{E}1$) will force all outputs to the inactive (HIGH) state and allow new data to settle without producing erroneous information at the outputs.

A Group Signal output ($\overline{G}S$) and an Enable Output ($\overline{E}O$) are provided with the three data outputs. The $\overline{G}S$ is active level LOW when any input is LOW; this indicates when any input is active. The $\overline{E}O$ is active level LOW when all inputs are HIGH. Using the output enable along with the input enable allows priority encoding of N input signals. Both $\overline{E}O$ and $\overline{G}S$ are inactive HIGH when the input enable is HIGH.

TABLE I — TRUTH TABLE

$\overline{E}1$	0	1	2	3	4	5	6	7	$\overline{G}S$	A_0	A_1	A_2	$\overline{E}O$
H	X	X	X	X	X	X	X	X	H	H	H	H	H
L	H	H	H	H	H	H	H	H	H	H	H	L	L
L	X	X	X	X	X	X	L	L	L	L	L	H	H
L	X	X	X	X	X	L	H	L	L	L	H	H	H
L	X	X	X	X	L	H	H	L	L	H	L	H	H
L	X	X	X	L	H	H	H	L	H	L	H	H	H
L	X	X	L	H	H	H	H	L	L	L	H	H	H
L	X	L	H	H	H	H	H	L	H	L	H	H	H
L	L	H	H	H	H	H	H	L	L	H	H	H	H
L	L	H	H	H	H	H	H	L	H	H	H	H	H

H = HIGH Voltage Level
L = LOW Voltage Level
X = Don't Care

TYPICAL INPUT AND OUTPUT CHARACTERISTICS

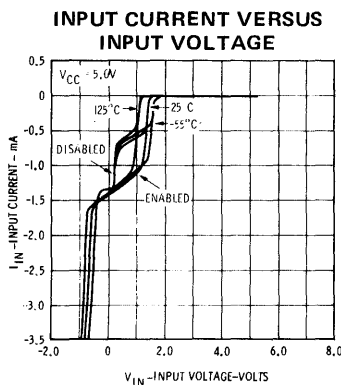
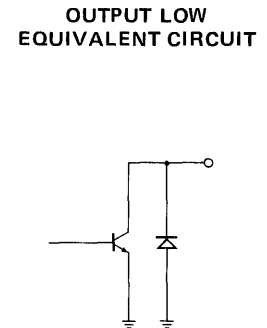
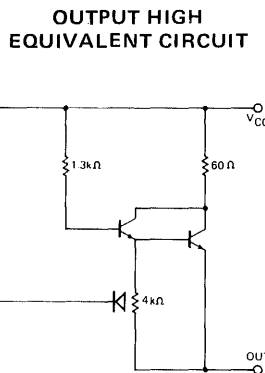
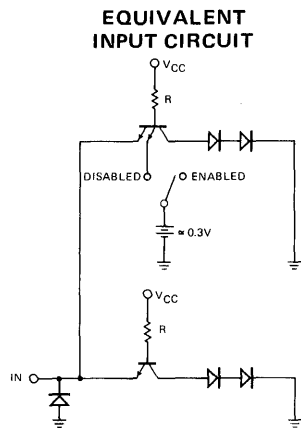

Fig. 1.

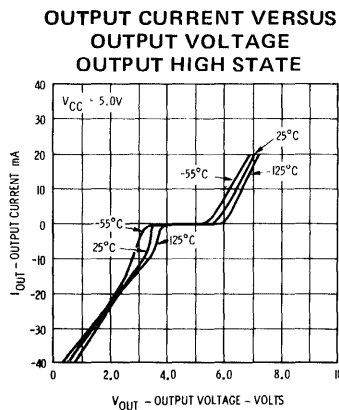

Fig. 2.

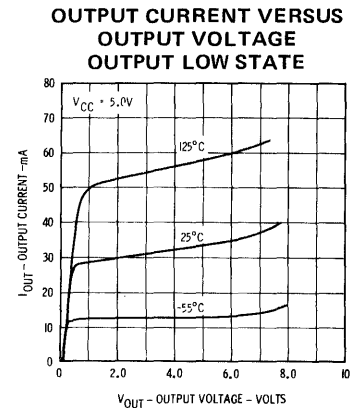

Fig. 3.

ABSOLUTE MAXIMUM RATINGS (above which the useful life may be impaired)

- Storage Temperature
- Temperature (Ambient) Under Bias
- V_{CC} Pin Potential to Ground Pin
- *Input Voltage (dc)
- *Input Current (dc)
- Voltage Applied to Outputs (Output HIGH)
- Output Current (dc) (Output LOW)

- 65°C to +150°C
- 55°C to +125°C
- 0.5 V to +7.0 V
- 0.5 V to +5.5 V
- 30 mA to +5.0 mA
- 0.5 V to + V_{CC} value
- +30 mA

*Either Input Voltage limit or Input Current limit is sufficient to protect the inputs.

FAIRCHILD TTL/MSI • 9318

GUARANTEED OPERATING RANGES

PART NUMBER	SUPPLY VOLTAGE (V _{CC})			TEMPERATURE
	MIN.	TYP.	MAX.	
9318XM	4.5 V	5.0 V	5.5 V	-55° C to 125° C
9318XC	4.75 V	5.0 V	5.25 V	0° C to 75° C

X = package type; F for Flatpak, D for Ceramic Dip, P for Plastic Dip. See Packaging Information Section for packages available on this product.

ELECTRICAL CHARACTERISTICS OVER OPERATING TEMPERATURE RANGE (unless otherwise noted)

SYMBOL	PARAMETER	LIMITS			UNITS	CONDITIONS
		MIN.	TYP. (Note 4)	MAX.		
V _{IH}	Input HIGH Voltage	2.0			Volts	Guaranteed Input HIGH Threshold Voltage for All Inputs
V _{IL}	Input LOW Voltage			0.8	Volts	Guaranteed Input LOW Threshold Voltage for All Inputs
V _{CD}	Input Clamp Diode Voltage			-1.5	Volts	V _{CC} = MIN., I _{IN} = -12mA, T _A = 25° C
V _{OH}	Output HIGH Voltage	2.4	3.6		Volts	V _{CC} = MIN., I _{OH} = -800 μA V _{IN} = V _{IH} or V _{IL} per Truth Table
V _{OL}	Output LOW Voltage		0.2	0.4	Volts	V _{CC} = MIN., I _{OL} = 16 mA V _{IN} = V _{IH} or V _{IL} per Truth Table
I _{IH}	Input HIGH Current I _O (Pin 10) E1, I ₁ -I ₇		10 20	40 80	μA	V _{CC} = MAX., V _{IN} = 2.4 V
	All Inputs			1.0	mA	V _{CC} = MAX., V _{IN} = 5.0 V
I _{IL}	Input LOW Current I _O (Pin 10) E1, I ₁ -I ₇		-0.96 -1.92	-1.6 -3.2	mA	V _{CC} = MAX., V _{IN} = 0.4 V
	Output Short Circuit Current (Note 5)	-30	-65	-100	mA	V _{CC} = MAX., V _{OUT} = 0 V
I _{CC}	Power Supply Current		50	77	mA	V _{CC} = MAX.

NOTES:

1. The actual testing procedures used to guarantee the Electrical Characteristics are contained in a detailed Customer Sample Specification. A copy of this specification can be obtained from Fairchild Digital Product Marketing, Mountain View, California.
2. Conditions for testing, not shown in the table, are chosen to guarantee operation under "worst case" conditions.
3. The specified LIMITS represent the "worst case" value for the parameter. Since these "worst case" values normally occur at the temperature and supply voltage extremes, additional noise immunity and guard banding can be achieved by decreasing the allowable system operating ranges.
4. Typical limits are at V_{CC} = 5.0 V, 25° C, and maximum loading.
5. Not more than one output should be shorted at a time.

SWITCHING CHARACTERISTICS (T_A = 25° C)

SYMBOL	PARAMETER	9318XM(MIL)		9318XC(IND)		UNITS	CONDITIONS
		MIN.	MAX.	MIN.	MAX.		
t _{PLH}	Data Input to Enable Output	10		15		ns	V _{CC} = 5.0 V C _L = 15 pF
t _{PHL}		30		40		ns	
t _{PLH}	Enable Input to Group Signal	16		20		ns	
t _{PHL}		25		31		ns	
t _{PLH}	Enable Input to Enable Output	15		21		ns	
t _{PHL}		40		45		ns	
t _{PLH}	Enable Input to Data Output	20		25		ns	
t _{PHL}		25		30		ns	
t _{PLH}	Data Input to Group Signal	40		45		ns	
t _{PHL}		25		30		ns	
t _{PLH}	Data Input to Data Output	30		38		ns	
t _{PHL}		30		38		ns	

SWITCHING CHARACTERISTICS

DATA INPUT TO ENABLE OUTPUT

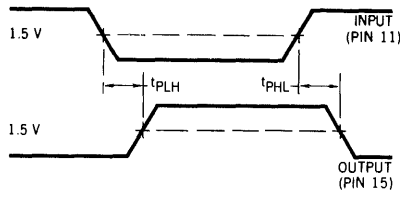

Other Conditions: Pin 5 = GND
Pins 1, 2, 3, 4, 10, 12, 13 =
V_{CC} through 750 Ω

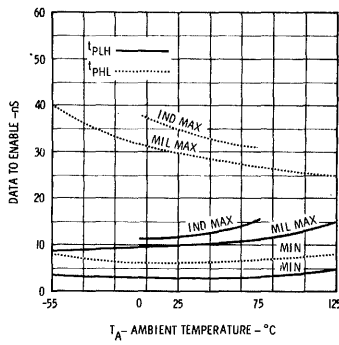
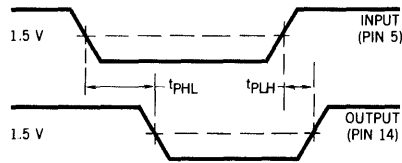

Fig. 4.

ENABLE INPUT TO GROUP SIGNAL



Other Conditions: Pin 10 = GND
Pins 1, 2, 3, 4, 11, 12, 13 =
V_{CC} through 750 Ω

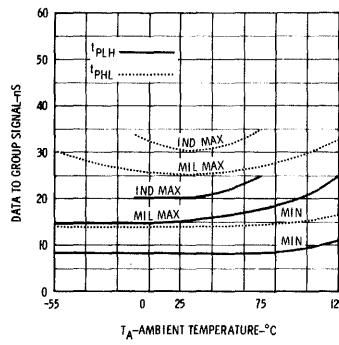
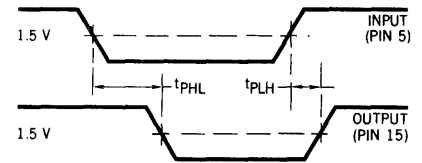

Fig. 5.

ENABLE INPUT TO ENABLE OUTPUT



Other Conditions:
Pins 1, 2, 3, 4, 10, 11, 12, 13 =
V_{CC} through 750 Ω

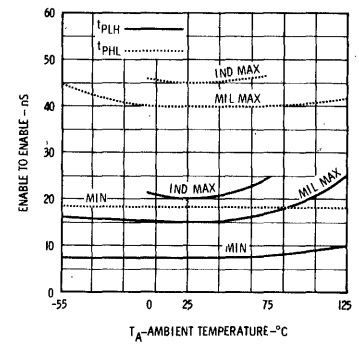
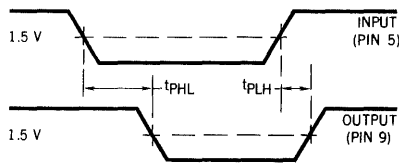

Fig. 6.

ENABLE INPUT TO DATA OUTPUT



Other Conditions: Pin 4 = GND
Pins 1, 2, 3, 10, 11, 12, 13 =
V_{CC} through 750 Ω

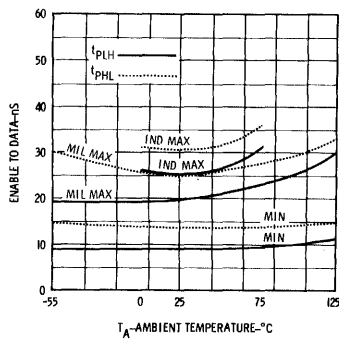
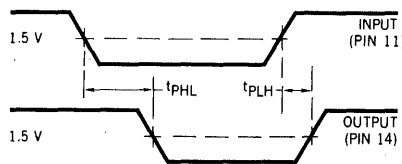

Fig. 7.

DATA INPUT TO GROUP SIGNAL



Other Conditions: Pin 5 = GND
Pins 1, 2, 3, 4, 10, 12, 13 =
V_{CC} through 750 Ω

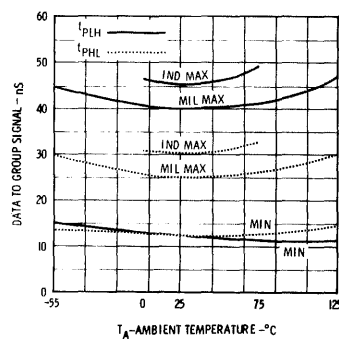
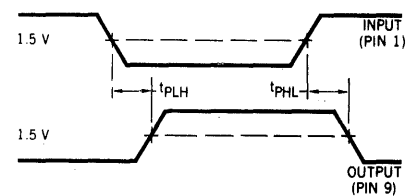

Fig. 8.

DATA INPUT TO DATA OUTPUT



Other Conditions: Pins 5, 11 = GND
Pins 2, 3, 4, 10, 12, 13 =
V_{CC} through 750 Ω

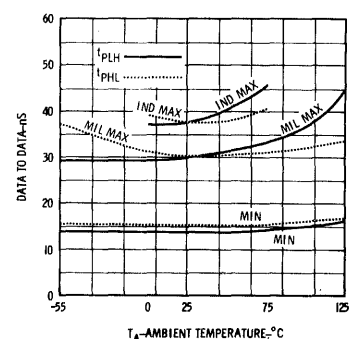

Fig. 9.

LPTTL/MSI 93L18

LOW POWER EIGHT-INPUT PRIORITY ENCODER

DESCRIPTION – The LPTTL/MSI 93L18 is a Multipurpose Encoder designed to accept eight inputs and produce a binary weighted code of the highest order input. The circuit uses TTL technology for high speed and high fanout capability, and is compatible with all Fairchild TTL families.

- **MULTI-FUNCTION CAPABILITY**
 - CODE CONVERSIONS
 - MULTI-CHANNEL D/A CONVERTER
 - DECIMAL TO BCD CONVERTER
 - CASCADING FOR PRIORITY ENCODING OF N BITS
- **INPUT ENABLE CAPABILITY**
- **PRIORITY ENCODING – AUTOMATIC SELECTION OF HIGHEST PRIORITY INPUT LINE**
- **OUTPUT ENABLE – ACTIVE LOW WHEN ALL INPUTS HIGH**
- **GROUP SIGNAL OUTPUT – ACTIVE WHEN ANY INPUT IS LOW**
- **TYPICAL PROPAGATION DELAY OF 55 ns**
- **TYPICAL POWER DISSIPATION OF 75 mW**
- **INPUT CLAMP DIODES LIMIT HIGH SPEED TERMINATION EFFECTS**
- **ALL CERAMIC HERMETIC 16-LEAD DUAL IN-LINE AND FLAT PACKAGES**
- **TTL COMPATIBLE**

PIN NAMES

$\bar{0}$	Priority (Active LOW) Input
$\bar{1}$ to $\bar{7}$	Priority (Active LOW) Inputs
\bar{EI}	Enable (Active LOW) Input
\bar{EO}	Enable (Active LOW) Output
\bar{GS}	Group Select (Active LOW) Output
$\bar{A}_0, \bar{A}_1, \bar{A}_2$	Address (Active LOW) Outputs

LOADING

	HIGH	LOW
$\bar{0}$	0.5 U.L.	0.25 U.L.
$\bar{1}$ to $\bar{7}$	1.0 U.L.	0.5 U.L.
\bar{EI}	1.0 U.L.	0.5 U.L.
\bar{EO}	10 U.L.	1.25 U.L.
\bar{GS}	10 U.L.	1.5 U.L.
$\bar{A}_0, \bar{A}_1, \bar{A}_2$	10 U.L.	2.5 U.L.

1 Unit Load (U.L.) = 40 μ A HIGH/1.6 mA LOW

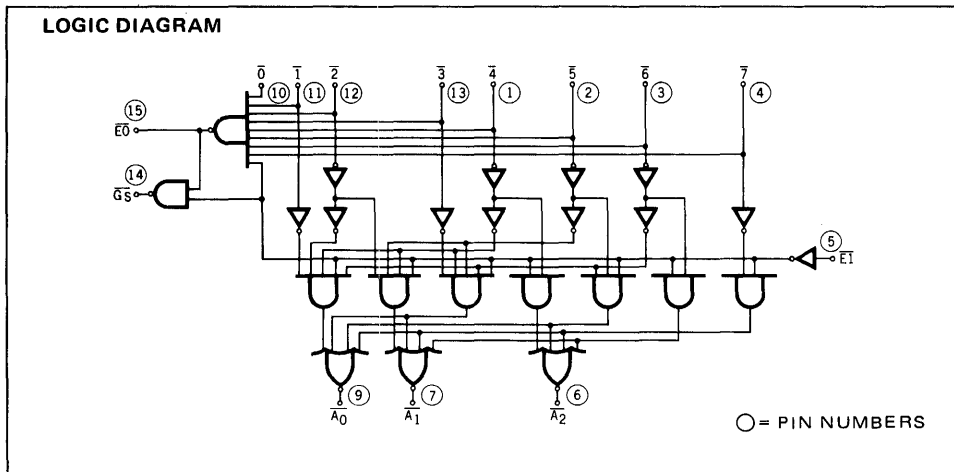

LOGIC SYMBOL

V_{CC} = Pin 16
 GND = Pin 8

CONNECTION DIAGRAMS
DIP (TOP VIEW)

FLATPAK (TOP VIEW)

FAIRCHILD LPTTL/MSI • 93L18

FUNCTIONAL DESCRIPTION – The LPTTL/MSI 93L18 8-input priority encoder accepts data from eight active LOW inputs and provides a binary representation on the three active LOW outputs. A priority is assigned to each input so that when two or more inputs are simultaneously active, the input with the highest priority is represented on the output, with input line 7 having the highest priority.

A HIGH on the input enable (\overline{EI}) will force all outputs to the inactive (HIGH) state and allow new data to settle without producing erroneous information at the outputs.

Provided with the three data outputs are a group signal output (\overline{GS}) and an enable output (\overline{EO}). The \overline{GS} is active level LOW when any input is LOW; this indicates when any input is active. The \overline{EO} is active level LOW when all inputs are HIGH. Using the output enable along with the input enable allows priority encoding of N input signals. Both \overline{EO} and \overline{GS} are inactive when the input enable is HIGH.

TRUTH TABLE

\overline{EI}	$\overline{0}$	$\overline{1}$	$\overline{2}$	$\overline{3}$	$\overline{4}$	$\overline{5}$	$\overline{6}$	$\overline{7}$	\overline{GS}	$\overline{A_0}$	$\overline{A_1}$	$\overline{A_2}$	\overline{EO}
H	X	X	X	X	X	X	X	X	H	H	H	H	H
L	H	H	H	H	H	H	H	H	H	H	H	H	L
L	X	X	X	X	X	X	X	L	L	L	L	L	H
L	X	X	X	X	X	X	L	H	L	L	L	L	H
L	X	X	X	X	X	L	H	H	L	L	L	L	H
L	X	X	X	L	H	H	H	H	L	L	L	L	H
L	X	X	L	H	H	H	H	H	L	L	L	L	H
L	X	L	H	H	H	H	H	H	L	L	L	L	H
L	L	H	H	H	H	H	H	H	L	L	L	L	H

H = HIGH Voltage Level
 L = LOW Voltage Level
 X = Don't Care

TYPICAL INPUT AND OUTPUT CIRCUITS

INPUTS EQUIVALENT CIRCUIT

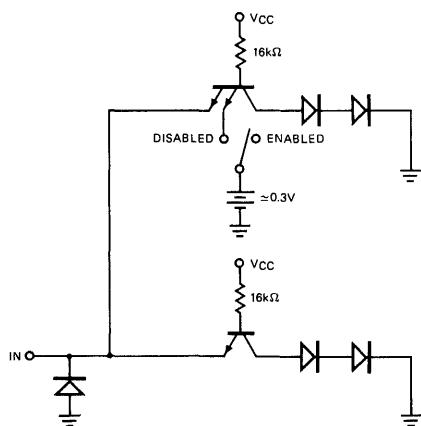

OUTPUTS EQUIVALENT CIRCUIT

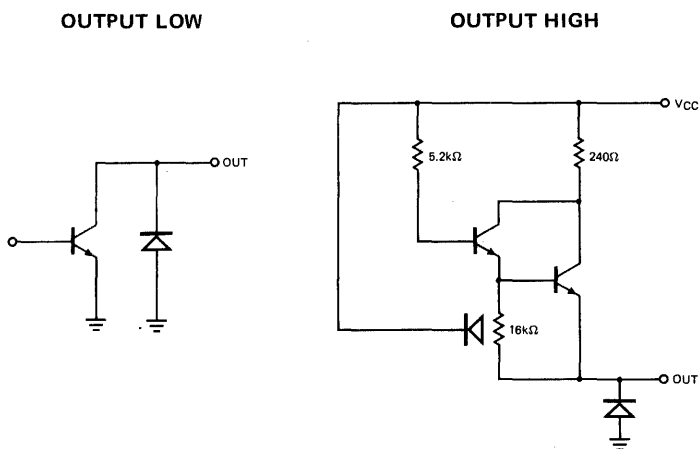

ABSOLUTE MAXIMUM RATINGS (above which the useful life may be impaired)

Storage Temperature	–65° C to +150° C
Temperature (Ambient) Under Bias	–55° C to +125° C
V _{CC} Pin Potential to Ground Pin	–0.5 V to +7.0 V
*Input Voltage (dc)	–0.5 V to +5.5 V
*Input Current (dc)	–30 mA to +5.0 mA
Voltage Applied to Outputs (Output HIGH)	–0.5 V to +V _{CC} value
Output Current (dc) (Output LOW)	+30 mA

*Either Input Voltage limit or Input Current limit is sufficient to protect the inputs.

FAIRCHILD LPTTL/MSI • 93L18

GUARANTEED OPERATING RANGES

PART NUMBER	SUPPLY VOLTAGE (V _{CC})			TEMPERATURE
	MIN.	TYP.	MAX.	
93L18XM	4.5 V	5.0 V	5.5 V	-55°C to 125°C
93L18XC	4.75 V	5.0 V	5.25 V	0°C to 75°C

X = package type; F for Flatpak, D for Ceramic Dip, P for Plastic Dip. See Packaging Information Section for packages available on this product.

ELECTRICAL CHARACTERISTICS OVER OPERATING TEMPERATURE RANGE (unless otherwise noted)

SYMBOL	PARAMETER	LIMITS			UNITS	CONDITIONS
		MIN.	TYP. (Note 4)	MAX.		
V _{OH}	Output HIGH Voltage	2.4	3.6		Volts	V _{CC} = MIN., I _{OH} = -0.4 mA V _{IN} = V _{IH} or V _{IL} per Truth Table
V _{OL}	Output LOW Voltage		0.15	0.3	Volts	V _{CC} = MIN., I _{OL} = 4.0 mA (Pins 6, 7, 9) I _{OL} = 2.4 mA (Pin 14) I _{OL} = 2.0 mA (Pin 15) V _{IN} = V _{IH} or V _{IL} per Truth Table
V _{IH}	Input HIGH Voltage	2.0			Volts	Guaranteed Input HIGH Threshold Voltage for All Inputs
V _{IL}	Input LOW Voltage			0.7	Volts	Guaranteed Input LOW Threshold Voltage for All Inputs
I _{IL}	Input LOW Current Input 0 (Pin 10) Inputs 1 thru 7 & E1		-0.25 -0.50	-0.4 -0.8	mA	V _{CC} = MAX., V _{IN} = 0.3 V
I _{IH}	Input HIGH Current Input 0 (Pin 10) Inputs 1 thru 7 & E1		2.0 4.0	20 40	μA	V _{CC} = MAX., V _{IN} = 2.4 V
I _{SC} (Note 5)	Output Short Circuit Current	-10	-22	-40	mA	V _{CC} = MAX., V _{OUT} = 0 V
I _{CC}	Power Supply Current		15	22	mA	V _{CC} = MAX., Pins 4 & 5 at GND

NOTES:

1. The actual testing procedures used to guarantee the Electrical Characteristics are contained in a detailed Customer Sample Specification. A copy of this specification can be obtained from Fairchild Digital Product Marketing, Mountain View, California.
2. Conditions for testing, not shown in the table, are chosen to guarantee operation under "worst case" conditions.
3. The specified LIMITS represent the "worst case" value for the parameter. Since these "worst case" values normally occur at the temperature and supply voltage extremes, additional noise immunity and guard banding can be achieved by decreasing the allowable system operating ranges.
4. Typical limits are at V_{CC} = 5.0 V, 25°C, and maximum loading.
5. Not more than one output should be shorted at a time.

SWITCHING CHARACTERISTICS (T_A = 25°C, V_{CC} = 5.0 V, Pin 8 = GND)

SYMBOL	PARAMETER	LIMITS			UNITS	CONDITIONS
		MIN.	TYP.	MAX.		
t _{PLH}	Data Input to Enable Output		10	15	ns	See Figure 1
t _{PHL}	Data Input to Enable Output		68	100		
t _{PLH}	Enable Input to Group Signal		16	27	ns	See Figure 2
t _{PHL}	Enable Input to Group Signal		38	57		
t _{PLH}	Enable Input to Enable Output		16	27	ns	See Figure 3
t _{PHL}	Enable Input to Enable Output		68	100		
t _{PLH}	Enable Input to Data Output		23	35	ns	See Figure 4
t _{PHL}	Enable Input to Data Output		38	57		
t _{PLH}	Data Input to Group Signal		59	89	ns	See Figure 5
t _{PHL}	Data Input to Group Signal		38	57		
t _{PLH}	Data Input to Data Output		33	50	ns	See Figure 6
t _{PHL}	Data Input to Data Output		51	77		

TYPICAL SWITCHING CHARACTERISTICS

All measurements are made with $V_{CC} = 5.0$ V applied to Pin 16 and Pin 8 grounded. The active input is driven by a 9002 TTL gate. The input and output pins under test are loaded with 15 pF of capacitance. (This includes probe & jig capacitance.)

Fig. 1. Data Input to Enable Output

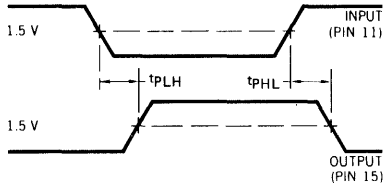

Other Conditions: Pin 5 = GND
Pins 1, 2, 3, 4, 10, 12, 13 = V_{CC} through 750 Ω

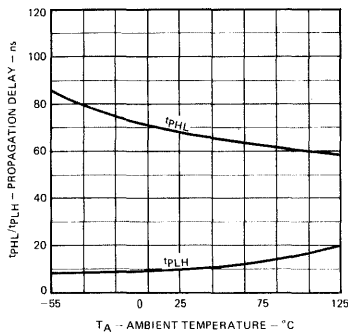
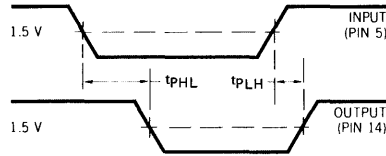

Fig. 2. Enable Input to Group Signal



Other Conditions: Pin 10 = GND
Pins 1, 2, 3, 4, 11, 12, 13 = V_{CC} through 750 Ω

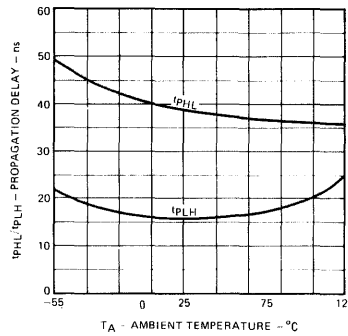
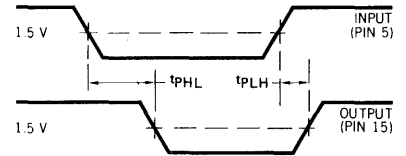

Fig. 3. Enable Input to Enable Output



Other Conditions: Pins 1, 2, 3, 4, 10, 11, 12, 13 = V_{CC} through 750 Ω

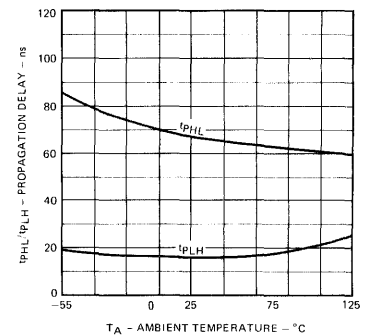
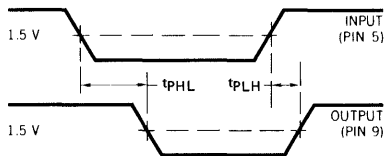

Fig. 4. Enable Input to Data Output



Other Conditions: Pin 4 = GND
Pins 1, 2, 3, 10, 11, 12, 13 = V_{CC} through 750 Ω

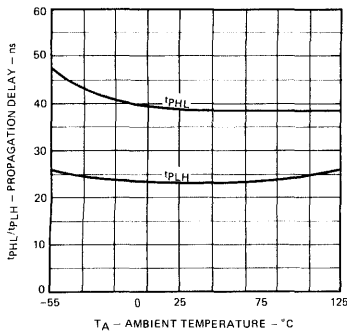
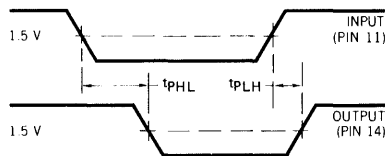

Fig. 5. Data Input to Group Signal



Other Conditions: Pin 5 = GND
Pins 1, 2, 3, 4, 10, 12, 13 = V_{CC} through 750 Ω

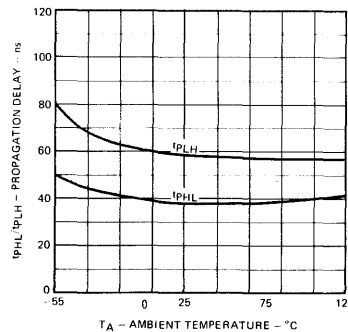
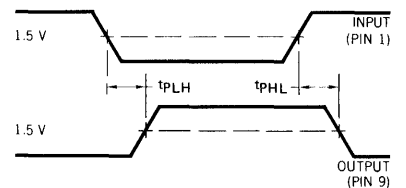
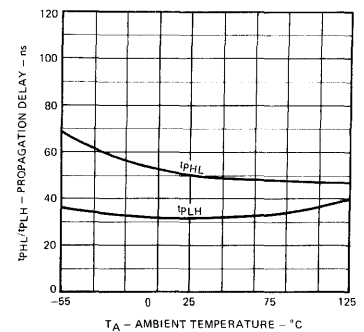

Fig. 6. Data Input to Data Output



Other Conditions: Pins 5, 11 = GND
Pins 2, 3, 4, 10, 12, 13 = V_{CC} through 750 Ω



TTL/MSI 9321

DUAL ONE-OF-FOUR DECODER

DESCRIPTION — The TTL/MSI 9321 consists of two Independent Multipurpose Decoders, each designed to accept two inputs and provide four mutually exclusive outputs. In addition, an active LOW enable input is provided for each decoder which gives demultiplexing capability. The circuit uses TTL for high speed and high fanout capability, and is compatible with all members of the Fairchild TTL family.

- MULTI-FUNCTION CAPABILITY
- MUTUALLY EXCLUSIVE OUTPUTS
- GUARANTEED FANOUT OF 10 TTL LOADS OVER THE FULL TEMPERATURE RANGE AND SUPPLY VOLTAGE RANGES
- HIGH CAPACITIVE DRIVE CAPABILITY
- DEMULTIPLEXING CAPABILITY
- TYPICAL POWER DISSIPATION OF 150 mW
- THE INPUT / OUTPUT CHARACTERISTICS PROVIDE EASY INTERFACING WITH FAIRCHILD MSI, DTL, LPDTL AND TTL FAMILIES
- ALL CERAMIC "HERMETIC" 16-LEAD DUAL IN-LINE PACKAGE
- INPUT CLAMP DIODES LIMIT HIGH SPEED LINE TERMINATION EFFECTS
- ACTIVE LOW ENABLE FOR EACH DECODER

PIN NAMES

Decoder 1 and 2

\bar{E}	Enable (Active LOW) Input
A_0, A_1	Address Inputs
$\bar{0}, \bar{1}, \bar{2}, \bar{3}$	(Active LOW) Outputs (Note b)

LOADING

(Note a)

1 U.L.
1 U.L.
10 U.L.

Notes:

- a. 1 Unit Load (U.L.) = 40 μ A HIGH/1.6 mA LOW
 b. 10 U.L. is the output LOW drive factor and 20 U.L. is the output HIGH drive factor.

LOGIC DIAGRAM

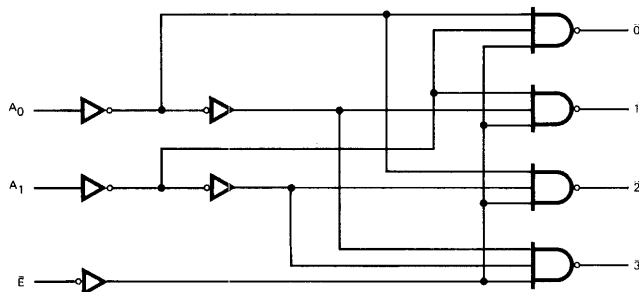

Note: Only one Decoder shown.

LOGIC SYMBOL

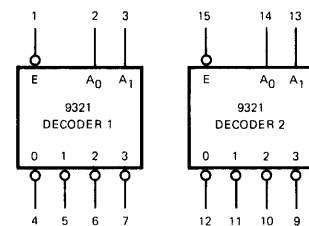

V_{CC} = Pin 16
 GND = Pin 8

CONNECTION DIAGRAMS

DIP (TOP VIEW)

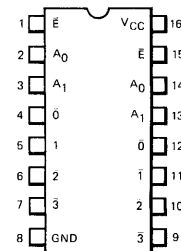

FLATPAK (TOP VIEW)

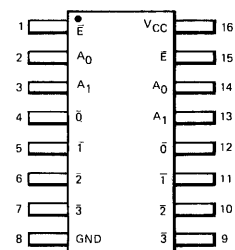

FUNCTIONAL DESCRIPTION — The 9321 consists of two separate decoders each designed to accept two binary weighted inputs and provide four mutually exclusive active LOW outputs as shown in logic symbol. Each decoder can be used as a 4-output demultiplexer by using the enable as a data input.

The active LOW outputs facilitate memory addressing for units such as the 93402 associative memory. The active LOW outputs are also compatible with the active LOW enables of other MSI elements making the 9321 useful in logic selection schemes.

**TRUTH TABLE
DECODER 1 & 2**

\bar{E}	A ₀	A ₁	$\bar{0}$	$\bar{1}$	$\bar{2}$	$\bar{3}$
L	L	L	L	H	H	H
L	H	L	H	L	H	H
L	L	H	H	H	L	H
L	H	H	H	H	H	L
H	X	X	H	H	H	H

H = HIGH Voltage Level
L = LOW Voltage Level
X = Level Does Not Affect Output

TYPICAL INPUT AND OUTPUT CHARACTERISTICS

**INPUTS
EQUIVALENT CIRCUIT**

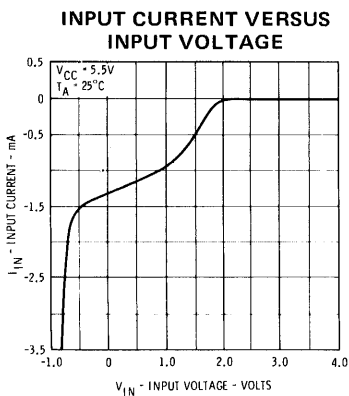
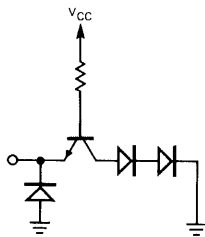

Fig. 1

**OUTPUTS
EQUIVALENT CIRCUIT
OUTPUT HIGH**

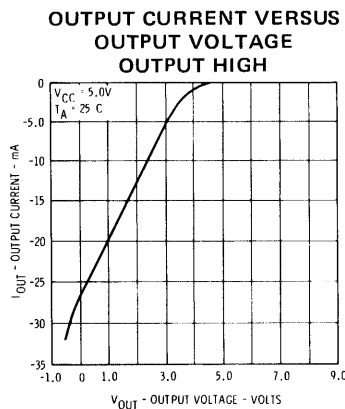
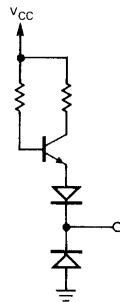

Fig. 2

**EQUIVALENT CIRCUIT
OUTPUT LOW**

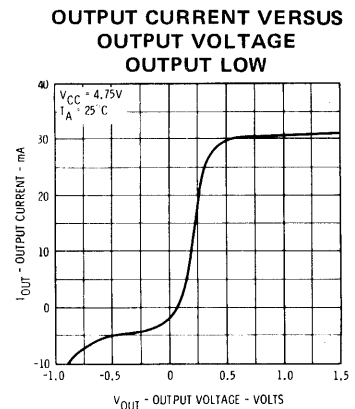
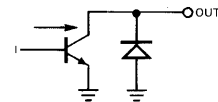

Fig. 3

ABSOLUTE MAXIMUM RATINGS (above which the useful life may be impaired)

- Storage Temperature -65°C to +150°C
- Temperature (Ambient) Under Bias -55°C to +125°C
- V_{CC} Pin Potential to Ground Pin -0.5 V to +7.0 V
- *Input Voltage (dc) -0.5 V to +5.5 V
- *Input Current (dc) -30 mA to +5.0 mA
- Voltage Applied to Outputs (Output HIGH) -0.5 V to +V_{CC} value
- Output Current (dc) (Output LOW) +30 mA

*Either Input Voltage limit or Input Current limit is sufficient to protect the inputs.

FAIRCHILD TTL/MSI • 9321

GUARANTEED OPERATING RANGES

PART NUMBER	SUPPLY VOLTAGE (V _{CC})			TEMPERATURE
	MIN.	TYP.	MAX.	
9321XM	4.5 V	5.0 V	5.5 V	-55°C to 125°C
9321XC	4.75 V	5.0 V	5.25 V	0°C to 75°C

X=package type; F for Flatpak, D for Ceramic Dip, P for Plastic Dip. See Packaging Information Section for packages available on this product.

ELECTRICAL CHARACTERISTICS OVER OPERATING TEMPERATURE RANGE (unless otherwise noted)

SYMBOL	PARAMETER	LIMITS			UNITS	CONDITIONS
		MIN.	TYP. (Note 4)	MAX.		
V _{IH}	Input HIGH Voltage	2.0			Volts	Guaranteed Input HIGH Threshold Voltage for All Inputs
V _{IL}	Input LOW Voltage			0.8	Volts	Guaranteed Input LOW Threshold Voltage for All Inputs
V _{CD}	Input Clamp Diode Voltage			-1.5	Volts	V _{CC} = MIN., I _{IN} = -12 mA., T _A = 25°C
V _{OH}	Output HIGH Voltage	2.4	3.6		Volts	V _{CC} = MIN., I _{OH} = -800 μA V _{IN} = V _{IH} or V _{IL} per Truth Table
V _{OL}	Output LOW Voltage		0.2	0.4	Volts	V _{CC} = MIN., I _{OL} = 16 mA V _{IN} = V _{IH} or V _{IL} per Truth Table
I _{IH}	Input HIGH Current		10	40	μA	V _{CC} = MAX., V _{IN} = 2.4 V
					1.0	mA
I _{IL}	Input LOW Current		-0.96	-1.6	mA	V _{CC} = MAX., V _{IN} = 0.4 V
I _{SC} (I _{OS})	Output Short Circuit Current (Note 5)	-20	-40	-70	mA	V _{CC} = MAX., V _{OUT} = 0 V
I _{CC}	Power Supply Current		30	50	mA	V _{CC} = MAX.

NOTES:

- The actual testing procedures used to guarantee the Electrical Characteristics are contained in a detailed Customer Sample Specification. A copy of this specification can be obtained from Fairchild Digital Product Marketing, Mountain View, California.
- Conditions for testing, not shown in the table, are chosen to guarantee operation under "worst case" conditions.
- The specified LIMITS represent the "worst case" value for the parameter. Since these "worst case" values normally occur at the temperature and supply voltage extremes, additional noise immunity and guard banding can be achieved by decreasing the allowable system operating ranges.
- Typical limits are at V_{CC} = 5.0 V, 25°C, and maximum loading.
- Not more than one output should be shorted at a time.

SWITCHING CHARACTERISTICS (T_A = 25°C)

SYMBOL	PARAMETER	LIMITS			UNITS	CONDITIONS
		MIN.	TYP.	MAX.		
t _{PLH}	Turn Off Delay A Input to Output		13	20	ns	See Figure 4 V _{CC} = 5.0 V C _L = 15 pF
t _{PHL}	Turn On Delay A Input to Output		14	21	ns	
t _{PLH}	Turn Off Delay E Input to Output		9	14	ns	See Figure 5
t _{PHL}	Turn On Delay E Input to Output		12	18	ns	

SWITCHING CHARACTERISTICS

ADDRESS INPUT TO OUTPUT

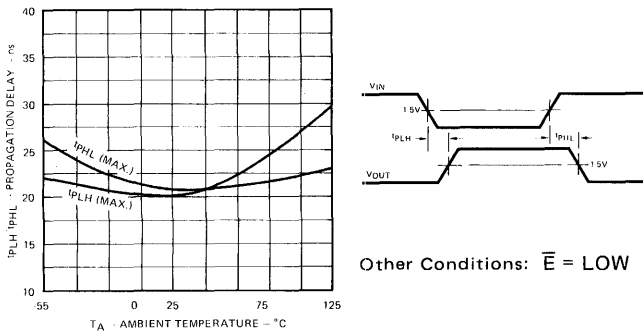

Fig. 4.

ENABLE INPUT TO OUTPUT

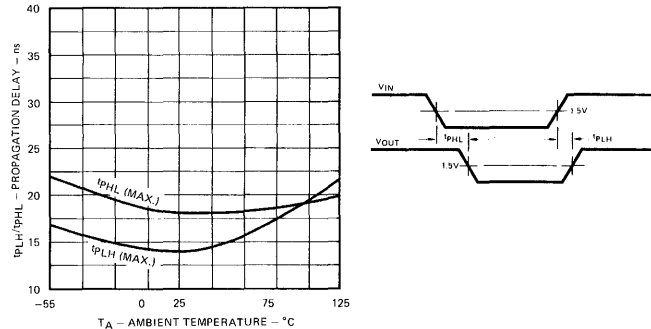

Fig. 5.

LPTTL/MSI 93L21

LOW POWER DUAL ONE-OF-FOUR DECODER

DESCRIPTION — The LPTTL/MSI 93L21 consists of two independent multipurpose decoders, each designed to accept two inputs and provide four mutually exclusive outputs. In addition an active LOW enable input is provided for each decoder which gives demultiplexing capability. The circuit uses TTL technology and is compatible with the Fairchild TTL family.

- MULTI-FUNCTION CAPABILITY
- MUTUALLY EXCLUSIVE OUTPUTS
- HIGH CAPACITIVE DRIVE CAPABILITY
- DEMULTIPLEXING CAPABILITY
- ACTIVE LOW ENABLE FOR EACH DECODER
- TYPICAL PROPAGATION DELAY OF 50 ns
- TYPICAL POWER DISSIPATION OF 45 mW
- INPUT CLAMP DIODES LIMIT HIGH SPEED LINE TERMINATION EFFECTS
- ALL CERAMIC "HERMETIC" 16-LEAD DUAL IN-LINE AND FLAT PACKAGES
- TTL COMPATIBLE

PIN NAMES
Decoder 1 and 2

\bar{E}
 A_0, A_1
 $\bar{0}, \bar{1}, \bar{2}, \bar{3}$

Enable (Active LOW) Input
Address Inputs
(Active LOW) Outputs

LOADING	
HIGH	LOW
0.5 U.L.	0.25 U.L.
0.5 U.L.	0.25 U.L.
10 U.L.	2.5 U.L.

1 Unit Load (U.L.) = 40 μ A HIGH/1.6 mA LOW.

LOGIC SYMBOL

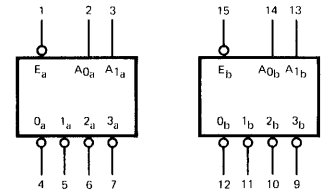

V_{CC} = Pin 16
GND = Pin 8

CONNECTION DIAGRAMS
DIP (TOP VIEW)

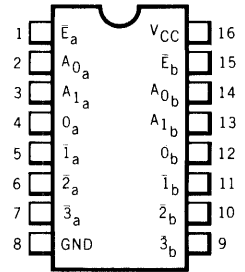

FLATPAK(TOP VIEW)

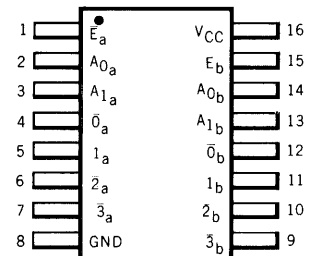

LOGIC DIAGRAM

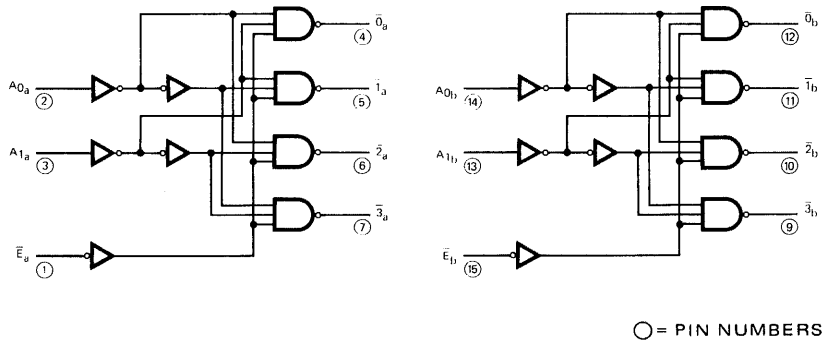

FAIRCHILD LPTTL/MSI • 93L21

FUNCTIONAL DESCRIPTION — The 93L21 consists of two separate decoders each designed to accept two binary weighted inputs and provide four mutually exclusive active LOW outputs as shown in logic symbol. Each decoder can be used as a four output demultiplexer by using the enable as a data input.

The active LOW outputs facilitate memory addressing for units such as the 93402 associative memory. The active LOW outputs are also compatible with the active LOW enables of other LPTTL/MSI elements making the 93L21 useful in logic selection schemes.

**TRUTH TABLE
DECODER I & II**

\bar{E}	A_0	A_1	$\bar{0}$	$\bar{1}$	$\bar{2}$	$\bar{3}$
L	L	L	L	H	H	H
L	H	L	H	L	H	H
L	L	H	H	H	L	H
L	H	H	H	H	H	L
H	X	X	H	H	H	H

H = HIGH Voltage Level
 L = LOW Voltage Level
 X = Level Does Not Affect Output

TYPICAL INPUT AND OUTPUT CIRCUITS

INPUTS EQUIVALENT CIRCUIT

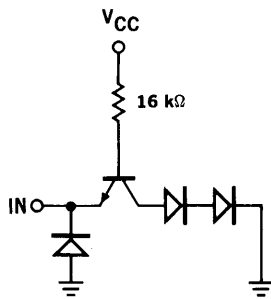

OUTPUTS EQUIVALENT CIRCUITS

OUTPUT LOW

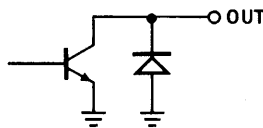

OUTPUT HIGH

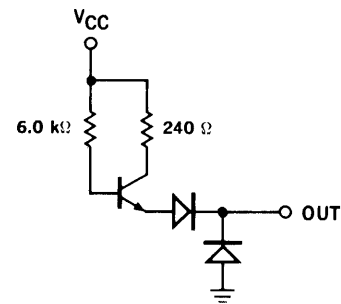

ABSOLUTE MAXIMUM RATINGS (above which the useful life may be impaired)

Storage Temperature	-65° C to +150° C
Temperature (Ambient) Under Bias	-55° C to +125° C
V _{CC} Pin Potential to Ground Pin	-0.5 V to +7.0 V
*Input Voltage (dc)	-0.5 V to +5.5 V
*Input Current (dc)	-30 mA to +5.0 mA
Voltage Applied to Outputs (Output HIGH)	-0.5 V to +V _{CC} value
Output Current (dc) (Output LOW)	+30 mA

*Either Input Voltage limit or Input Current limit is sufficient to protect the inputs.

FAIRCHILD LPTTL/MSI • 93L21

GUARANTEED OPERATING RANGES

PART NUMBER	SUPPLY VOLTAGE (V _{CC})			TEMPERATURE
	MIN.	TYP.	MAX.	
93L21XM	4.5 V	5.0 V	5.5 V	-55°C to 125°C
93L21XC	4.75 V	5.0 V	5.25 V	0°C to 75°C

X = package type; F for Flatpak, D for Ceramic Dip, P for Plastic Dip. See Packaging Information Section for packages available on this product.

ELECTRICAL CHARACTERISTICS OVER OPERATING TEMPERATURE RANGE (unless otherwise noted)

SYMBOL	PARAMETER	LIMITS			UNITS	CONDITIONS
		MIN.	TYP. (Note 4)	MAX.		
V _{OH}	Output HIGH Voltage	2.4	3.6		Volts	V _{CC} = MIN., I _{OH} = -0.4 mA V _{IN} = V _{IH} or V _{IL} per Truth Table
V _{OL}	Output LOW Voltage		0.15	0.3	Volts	V _{CC} = MIN., I _{OL} = 4.0 mA V _{IN} = V _{IH} or V _{IL} per Truth Table
V _{IH}	Input HIGH Voltage	2.0			Volts	Guaranteed Input HIGH Threshold Voltage for All Inputs
V _{IL}	Input LOW Voltage			0.7	Volts	Guaranteed Input LOW Threshold Voltage for All Inputs
I _{IL}	Input LOW Current		-0.25	-0.4	mA	V _{CC} = MAX., V _{IN} = 0.3 V
I _{IH}	Input HIGH Current		2.0	20	μA	V _{CC} = MAX., V _{IN} = 2.4 V
				1.0	mA	V _{CC} = MAX., V _{IN} = 5.5 V
I _{SC} (Note 5)	Output Short Circuit Current	-2.5	-16	-25	mA	V _{CC} = MAX., V _{OUT} = 0 V
I _{CC}	Power Supply Current		9.0	13.2	mA	V _{CC} = MAX., All Inputs at GND

NOTES:

- The actual testing procedures used to guarantee the Electrical Characteristics are contained in a detailed Customer Sample Specification. A copy of this specification can be obtained from Fairchild Digital Product Marketing, Mountain View, California.
- Conditions for testing, not shown in the table, are chosen to guarantee operation under "worst case" conditions.
- The specified LIMITS represent the "worst case" value for the parameter. Since these "worst case" values normally occur at the temperature and supply voltage extremes, additional noise immunity and guard banding can be achieved by decreasing the allowable system operating ranges.
- Typical limits are at V_{CC} = 5.0 V, 25°C, and maximum loading.
- Not more than one output should be shorted at a time.

SWITCHING CHARACTERISTICS (T_A = 25°C)

SYMBOL	PARAMETER	LIMITS			UNITS	CONDITIONS
		MIN.	TYP.	MAX.		
t _{PLH}	Turn Off Delay A Input to Output		30	50	ns	V _{CC} = 5.0 V
t _{PHL}	Turn On Delay A Input to Output		43	65	ns	C _L = 15 pF, (See Fig. 1)
t _{PLH}	Turn Off Delay E Input to Output		23	40	ns	V _{CC} = 5.0 V
t _{PHL}	Turn On Delay E Input to Output		34	52	ns	C _L = 15 pF, (See Fig. 2)

SWITCHING TIME AND WAVEFORMS

All measurements are made with V_{CC} = 5.0 V applied to Pin 16 and Pin 8 grounded. The active input is driven by a 9002 TTL gate. The input and output pins under test are loaded with 15 pF of capacitance (this includes probe and jig capacitance).

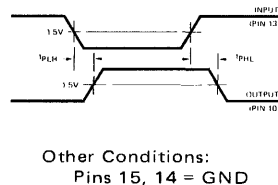
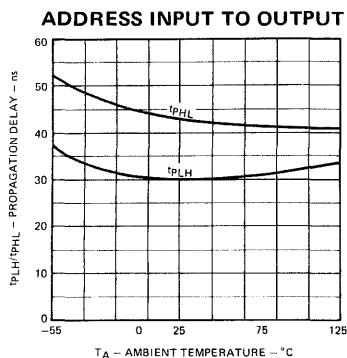

Fig. 1.

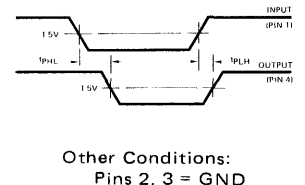
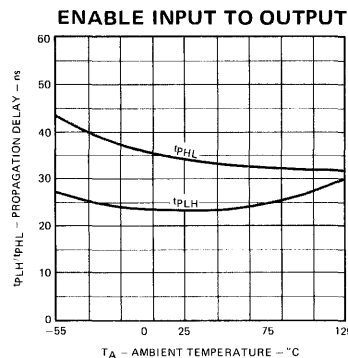

Fig. 2.

TTL/MSI 9322

QUAD TWO-INPUT MULTIPLEXER

DESCRIPTION – The TTL/MSI 9322 is a Monolithic, High Speed, Quad Two-Input Digital Multiplexer Circuit, constructed with the Fairchild Planar* epitaxial process. It consists of four multiplexing circuits with common select and enable logic; each circuit contains two inputs and one output. The circuit uses TTL for high speed, high fan out operation and is compatible with all other members of the Fairchild TTL family.

- **MULTIFUNCTION CAPABILITY***
- **20 ns THROUGH DELAY**
- **ON-CHIP SELECT LOGIC DECODING**
- **FULLY BUFFERED OUTPUTS**
- **THE INPUT/OUTPUT CHARACTERISTICS PROVIDE EASY INTERFACING WITH FAIRCHILD DTL, LPDTL, TTL, AND MSI FAMILIES**
- **INPUT CLAMP DIODES LIMIT HIGH SPEED TERMINATIONS EFFECTS**

PIN NAMES

S	Common Selected Input
\bar{E}	Enable (Active LOW) Inputs
$I_{0a}, I_{1a}, I_{0b}, I_{1b}$ $I_{0c}, I_{1c}, I_{0d}, I_{1d}$	Multiplexer Inputs
Z_a, Z_b, Z_c, Z_d	Multiplexer Output (Note b)

LOADING

(Note a)
1 U.L.
1 U.L.
1 U.L.
10 U.L.

Notes:

- 1 Unit Load (U.L.) = 40 μ A HIGH/1.6 mA LOW
- 10 U.L. is the output LOW drive factor and 20 U.L. is the output HIGH drive factor.

LOGIC SYMBOL

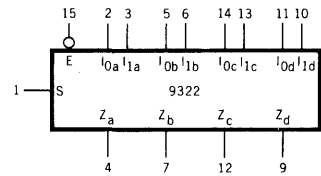

V_{CC} = Pin 16
GND = Pin 8

CONNECTION DIAGRAMS DIP (TOP VIEW)

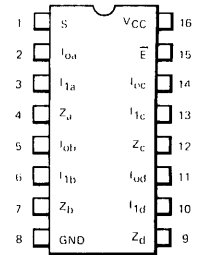

FLATPAK (TOP VIEW)

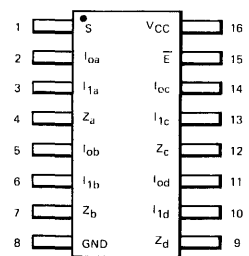

LOGIC DIAGRAM

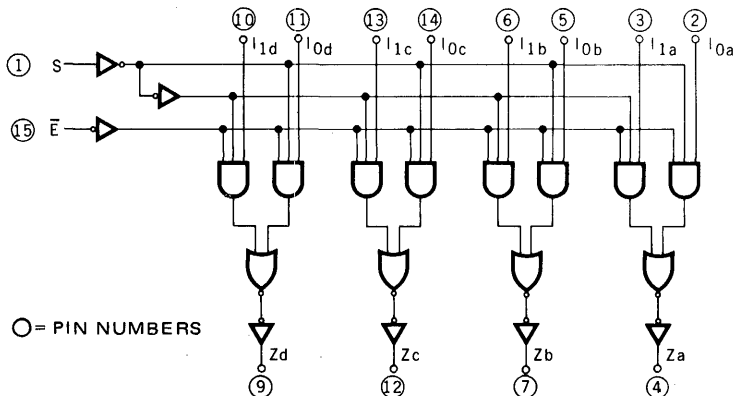

*Planar is a patented Fairchild process.

FUNCTIONAL DESCRIPTION — The 9322 quad 2-input multiplexer is a member of the Fairchild family of compatible Medium Scale Integrated (MSI) digital building blocks. It provides this family with the ability to select four bits of either data or control from two sources, in one package. The Enable input (\bar{E}) is active LOW. When not activated all outputs (Z) are LOW regardless of all other inputs.

The 9322 quad 2-input multiplexer is the logical implementation of a four-pole, two position switch, with the position of the switch being set by the logic levels supplied to the one select input. The logic equations for the outputs are shown below:

$$\begin{aligned} Z_a &= E \cdot (I_{1a} \cdot S + I_{0a} \cdot \bar{S}) & Z_b &= E \cdot (I_{1b} \cdot S + I_{0b} \cdot \bar{S}) \\ Z_c &= E \cdot (I_{1c} \cdot S + I_{0c} \cdot \bar{S}) & Z_d &= E \cdot (I_{1d} \cdot S + I_{0d} \cdot \bar{S}) \end{aligned}$$

A common use of the 9322 is the moving of data from a group of registers to four common output busses. The particular register from which the data comes is determined by the state of the select input. A less obvious use is as a function generator. The 9322 can generate four functions of two variables with one variable common. This is useful for implementing gating functions.

TRUTH TABLE

ENABLE	SELECT INPUT	INPUTS		OUTPUT
\bar{E}	S	I_{0X}	I_{1X}	ZX
H	X	X	X	L
L	H	X	L	L
L	H	X	H	H
L	L	L	X	L
L	L	H	X	H

H = HIGH Voltage Level
 L = LOW Voltage Level
 X = Either HIGH or LOW Logic Level

TYPICAL INPUT AND OUTPUT CHARACTERISTICS

INPUT EQUIVALENT CIRCUIT

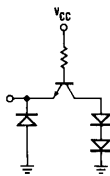

OUTPUT EQUIVALENT CIRCUIT (Output HIGH)

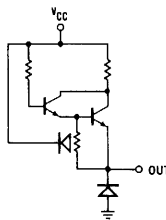

OUTPUT EQUIVALENT CIRCUIT (Output LOW)

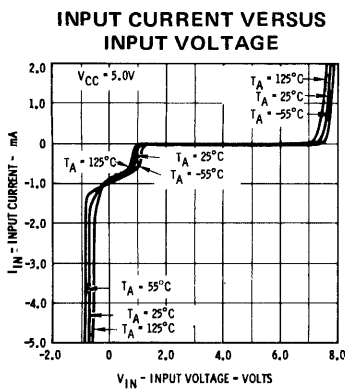
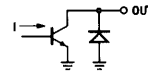

Fig. 1.

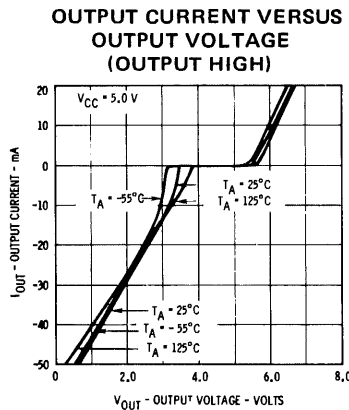

Fig. 2.

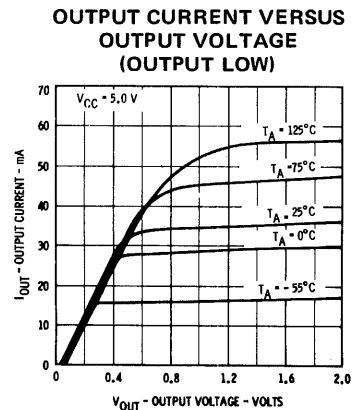

Fig. 3.

FAIRCHILD TTL/MSI • 9322

ABSOLUTE MAXIMUM RATINGS (above which the useful life may be impaired)

Storage Temperature	-65°C to +150°C
Temperature (Ambient) Under Bias	-55°C to +125°C
V _{CC} Pin Potential to Ground Pin	-0.5 V to +7.0 V
*Input Voltage (dc)	-0.5 V to +5.5 V
*Input Current (dc)	-30 mA to +5.0 mA
Voltage Applied to Outputs (Output HIGH)	-0.5 V to +V _{CC} value
Output Current (dc) (Output LOW)	+30 mA

*Either Input Voltage limit or Input Current limit is sufficient to protect the inputs.

GUARANTEED OPERATING RANGES

PART NUMBER	SUPPLY VOLTAGE (V _{CC})			TEMPERATURE
	MIN.	TYP.	MAX.	
9322XM	4.5 V	5.0 V	5.5 V	-55°C to 125°C
9322XC	4.75 V	5.0 V	5.25 V	0°C to 75°C

X = package type; F for Flatpak, D for Ceramic Dip, P for Plastic Dip. See Packaging Information Section for packages available on this product.

ELECTRICAL CHARACTERISTICS OVER OPERATING TEMPERATURE RANGE (unless otherwise noted)

SYMBOL	PARAMETER	LIMITS			UNITS	CONDITIONS
		MIN.	TYP. (Note 4)	MAX.		
V _{IH}	Input HIGH Voltage	2.0			Volts	Guaranteed Input HIGH Threshold Voltage for All Inputs
V _{IL}	Input LOW Voltage			0.8	Volts	Guaranteed Input LOW Threshold Voltage for All Inputs
V _{CD}	Input Clamp Diode Voltage			-1.5	Volts	V _{CC} = MIN., I _{IN} = -12 mA, T _A = 25°C
V _{OH}	Output HIGH Voltage	2.4	3.6		Volts	V _{CC} = MIN., I _{OH} = -800 μA V _{IN} = V _{IH} or V _{IL} per Truth Table
V _{OL}	Output LOW Voltage		0.2	0.4	Volts	V _{CC} = MIN., I _{OL} = 16 mA V _{IN} = V _{IH} or V _{IL} per Truth Table
I _{IH}	Input HIGH Current		10	40	μA	V _{CC} = MAX., V _{IN} = 2.4 V
				1.0	mA	V _{CC} = MAX., V _{IN} = 5.0 V
I _{IL}	Input LOW Current		-0.96	-1.6	mA	V _{CC} = MAX., V _{IN} = 0.4 V
I _{SC} (I _{OS})	Output Short Circuit Current (Note 5)	-30	-60	-100	mA	V _{CC} = MAX., V _{OUT} = 0 V
I _{CC}	Power Supply Current		30	47	mA	V _{CC} = MAX.

NOTES:

1. The actual testing procedures used to guarantee the Electrical Characteristics are contained in a detailed Customer Sample Specification. A copy of this specification can be obtained from Fairchild Digital Product Marketing, Mountain View, California.
2. Conditions for testing, not shown in the table, are chosen to guarantee operation under "worst case" conditions.
3. The specified LIMITS represent the "worst case" value for the parameter. Since these "worst case" values normally occur at the temperature and supply voltage extremes, additional noise immunity and guard banding can be achieved by decreasing the allowable system operating ranges.
4. Typical limits are at V_{CC} = 5.0 V, 25°C, and maximum loading.
5. Not more than one output should be shorted at a time.

SWITCHING CHARACTERISTICS (T_A = 25°C)

SYMBOL	PARAMETER	9322XM(MIL)			9322XC(IND)			UNITS	CONDITIONS	
		MIN.	TYP.	MAX.	MIN.	TYP.	MAX.			
t _{PLH}	Turn Off Delay Input to Output (S to Z)		17	25		17	30	ns	V _{CC} = 5.0 V C _L = 15 pF	See Figure 4
t _{PHL}	Turn On Delay Input to Output (S to Z)		20	27		20	31	ns		

SWITCHING CHARACTERISTICS

Fig. 4.

$t_{PLH}/t_{PHL} - S \text{ to } Z$

Other Conditions: $\bar{E} = L, I_0 = L, I_1 = H$

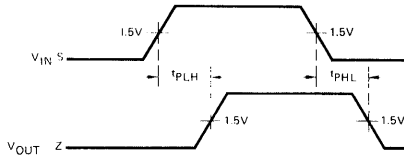

TURN OFF DELAY TIME
VERSUS AMBIENT TEMPERATURE
(S to Z)

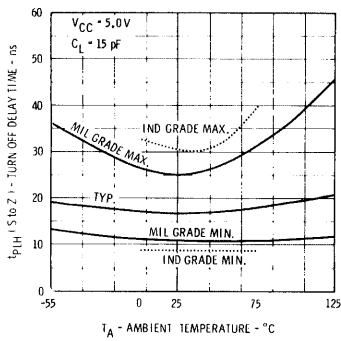

TURN ON DELAY TIME
VERSUS AMBIENT TEMPERATURE
(S to Z)

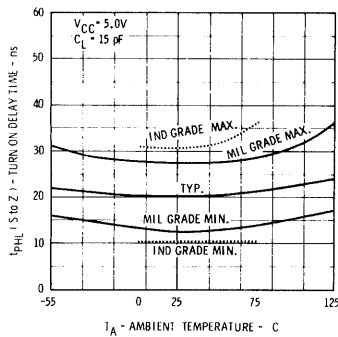
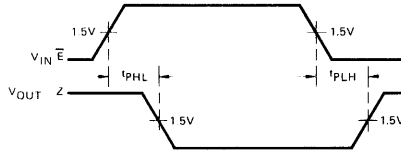

Fig. 5.

$t_{PLH}/t_{PHL} - \bar{E} \text{ to } Z$

Other Conditions: All Other Inputs HIGH



TURN OFF DELAY TIME
VERSUS AMBIENT TEMPERATURE
(\bar{E} to Z)

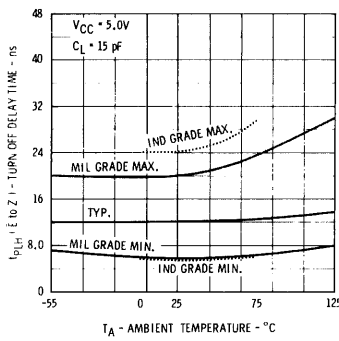

TURN ON DELAY TIME
VERSUS AMBIENT TEMPERATURE
(\bar{E} to Z)

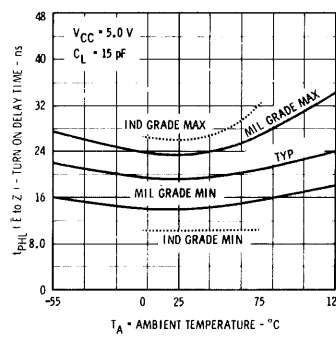
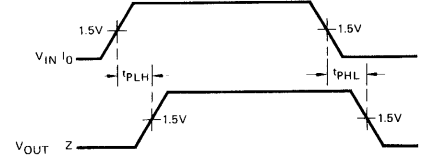

Fig. 6.

$t_{PLH}/t_{PHL} - I_0 \text{ to } Z$

Other Conditions: $\bar{E} = L, S = L$



TURN OFF DELAY TIME
VERSUS AMBIENT TEMPERATURE
(I_0 to Z)

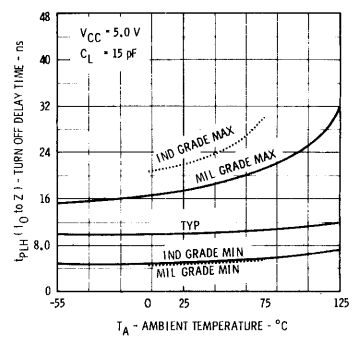

TURN ON DELAY TIME
VERSUS AMBIENT TEMPERATURE
(I_0 to Z)

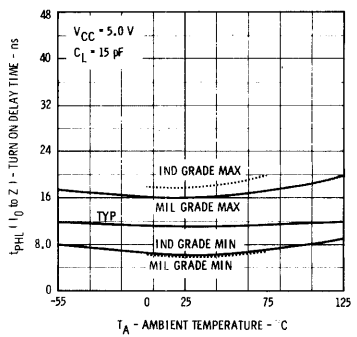

LPTTL/MSI 93L22

LOW POWER QUAD TWO-INPUT MULTIPLEXER

DESCRIPTION – The LPTTL/MSI 93L22 is a monolithic, medium speed, Quad Two-Input Digital Multiplexer, constructed with the Fairchild Planar* epitaxial process. It consists of four multiplexing circuits with common select and enable logic. Each circuit contains two inputs and one output. The circuit uses TTL technology and is compatible with the Fairchild TTL family.

- MULTIFUNCTION CAPABILITY
- ON-CHIP SELECT LOGIC DECODING
- TYPICAL PROPAGATION DELAY OF 44 ns
- TYPICAL POWER DISSIPATION OF 45 mW
- INPUT CLAMP DIODES LIMIT HIGH SPEED TERMINATION EFFECTS
- ALL CERAMIC "HERMETIC" 16-LEAD DUAL IN-LINE AND FLAT PACKAGES
- TTL COMPATIBLE

PIN NAMES

S_0	Common Select Input
\bar{E}	Enable (Active LOW) Input
I_0, I_1	Multiplexers Inputs
Z	Multiplexer Output

1 Unit Load (U.L.) = 40 μ A HIGH/1.6 mA LOW

LOADING	
HIGH	LOW
0.5 U.L.	0.25 U.L.
0.5 U.L.	0.25 U.L.
0.5 U.L.	0.25 U.L.
10 U.L.	2.5 U.L.

LOGIC SYMBOL

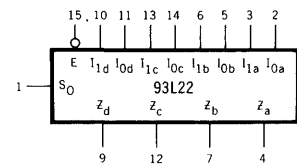

V_{CC} = Pin 16
GND = Pin 8

CONNECTION DIAGRAMS DIP (TOP VIEW)

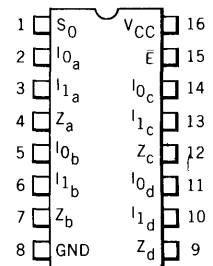

FLATPAK (TOP VIEW)

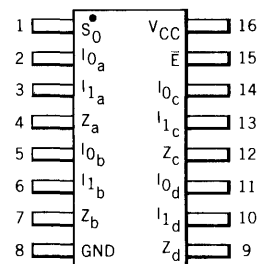

LOGIC DIAGRAM

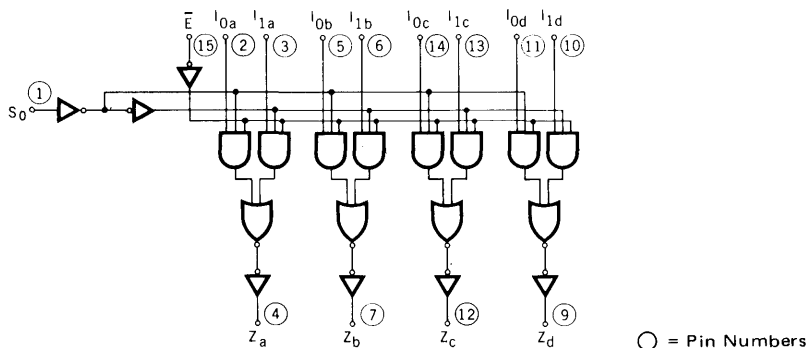

*Planar is a patented Fairchild process.

FAIRCHILD LPTTL/MSI • 93L22

FUNCTIONAL DESCRIPTION — The 93L22 quad two-input multiplexer is a member of the Fairchild family of low power medium scale integrated digital building blocks. It provides, in one package, the ability to select four bits of either data or control from four 2-bit sources. The enable input (\bar{E}) is active LOW. When not activated all outputs (Z) are LOW regardless of all other inputs. The 93L22 quad two input multiplexer is the logical implementation of a four-pole two position switch, with the position of the switch being set by the logic level supplied to the one select input. The logic equations for the outputs are shown below:

$$Z_a = E \cdot (I_{1a} \cdot S_0 + I_{0a} \cdot \bar{S}_0) \quad Z_b = E \cdot (I_{1b} \cdot S_0 + I_{0b} \cdot \bar{S}_0) \quad Z_c = E \cdot (I_{1c} \cdot S_0 + I_{0c} \cdot \bar{S}_0) \quad Z_d = E \cdot (I_{1d} \cdot S_0 + I_{0d} \cdot \bar{S}_0)$$

A common use of the 93L22 is the moving of data from two registers to common output busses. The particular register from which the data came would be determined by the state of the select input. A less obvious use is a function generator. The 93L22 can generate four functions of two variables with one variable common. This is useful implementing gating functions.

TRUTH TABLE
Identical for Each Multiplexer

ENABLE	SELECT INPUT	INPUTS		OUTPUT
\bar{E}	S_0	I_{0Y}	I_{1Y}	Z_Y
H	X	X	X	L
L	H	X	L	L
L	H	X	H	H
L	L	L	X	L
L	L	H	X	H

H = HIGH voltage level X = Level does not affect output
L = LOW voltage level Y = a, b, c, d

TYPICAL INPUT AND OUTPUT CHARACTERISTICS

INPUTS
EQUIVALENT CIRCUIT

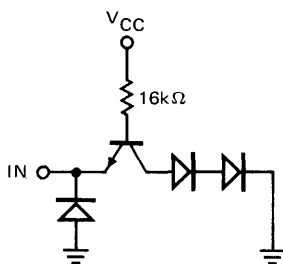

OUTPUTS
EQUIVALENT CIRCUITS

OUTPUT LOW

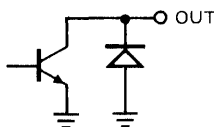

OUTPUT HIGH

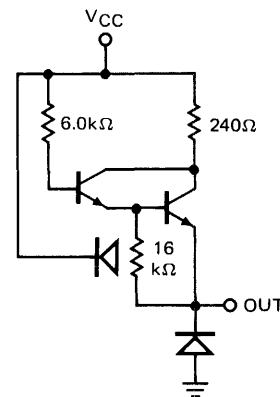

ABSOLUTE MAXIMUM RATINGS (above which the useful life may be impaired)

Storage Temperature	-65°C to +150°C
Temperature (Ambient) Under Bias	-55°C to +125°C
V_{CC} Pin Potential to Ground Pin	-0.5V to +7.0V
*Input Voltage (dc)	-0.5V to +5.5V
*Input Current (dc)	-30 mA to +5.0 mA
Voltage Applied to Outputs (Output HIGH)	-0.5V to + V_{CC} value
Output Current (dc) (Output LOW)	+30 mA

*Either Input Voltage limit or Input Current limit is sufficient to protect the inputs.

FAIRCHILD LPTTL/MSI • 93L22

GUARANTEED OPERATING RANGES

PART NUMBER	SUPPLY VOLTAGE (V _{CC})			TEMPERATURE
	MIN.	TYP.	MAX.	
93L22XM	4.5 V	5.0 V	5.5 V	-55° C to 125° C
93L22XC	4.75 V	5.0 V	5.25 V	0° C to 75° C

X = package type; F for Flatpak, D for Ceramic Dip, P for Plastic Dip. See Packaging Information Section for packages available on this product.

ELECTRICAL CHARACTERISTICS OVER OPERATING TEMPERATURE RANGE (Unless Otherwise Noted)

SYMBOL	PARAMETER	LIMITS			UNITS	CONDITIONS
		MIN.	TYP. (Note 4)	MAX.		
V _{OH}	Output HIGH Voltage	2.4	3.6		Volts	V _{CC} = MIN., I _{OH} = -0.4 mA V _{IN} = V _{IH} or V _{IL} per Truth Table
V _{OL}	Output LOW Voltage		0.15	0.3	Volts	V _{CC} = MIN., I _{OL} = 4.0 mA V _{IN} = V _{IH} or V _{IL} per Truth Table
V _{IH}	Input HIGH Voltage	2.0			Volts	Guaranteed input HIGH voltage for all inputs
V _{IL}	Input LOW Voltage			0.7	Volts	Guaranteed input LOW voltage for all inputs
I _{IL}	Input LOW Current		-0.25	-0.4	mA	V _{CC} = MAX., V _{IN} = 0.3V
I _{IH}	Input HIGH Current		2.0	20	μA	V _{CC} = MAX., V _{IN} = 2.4V
				1.0	mA	V _{CC} = MAX., V _{IN} = 5.5V
I _{SC} (Note 5)	Output Short Circuit Current	-10	-21	-40	mA	V _{CC} = MAX., V _{OUT} = 0.0V
I _{CC}	Power Supply Current		9.0	13.2	mA	V _{CC} = MAX.

NOTES:

- (1) The actual testing procedures used to guarantee the Electrical Characteristics are contained in a detailed Customer Sample Specification. A copy of this specification can be obtained from Fairchild Digital Product Marketing, Mountain View, California.
- (2) Conditions for testing, not shown in the Table, are chosen to guarantee operation under "worst case" conditions.
- (3) The specified LIMITS represent the "worst case" value for the parameter. Since these "worst case" values normally occur at the temperature and supply voltage extremes, additional noise immunity and guard banding can be achieved by decreasing the allowable system operating ranges.
- (4) Typical limits are at V_{CC} = 5.0 V, 25° C, and max. loading.
- (5) Not more than one output should be shorted at a time.

SWITCHING CHARACTERISTICS (T_A = 25° C)

SYMBOL	PARAMETER	LIMITS			UNITS	CONDITIONS
		MIN.	TYP.	MAX.		
t _{PLH} (S ₀ to Z)	Turn Off Delay Input to Output		26	36	ns	V _{CC} = 5.0 V
t _{PHL} (S ₀ to Z)	Turn On Delay Input to Output		36	49	ns	C _L = 15 pF

SWITCHING TIME WAVEFORMS

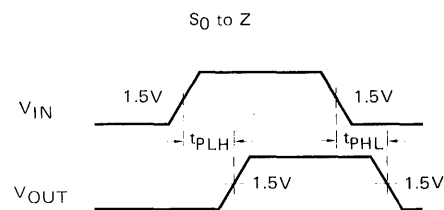

TTL/MSI 9324

5-BIT COMPARATOR

DESCRIPTION — The TTL/MSI 9324 is a High Speed Expandable Comparator which provides comparison between two 5-bit words and gives three outputs, "less than", "greater than" and "equal to". A HIGH level on the active LOW enable input forces all three outputs LOW.

- THREE SEPARATE OUTPUTS . . . $A < B$, $A > B$, $A = B$
- EASILY EXPANDABLE
- ACTIVE LOW LEVEL ENABLE INPUT
- HIGH DRIVE OUTPUT CIRCUITRY
- INPUT CLAMP DIODES LIMIT HIGH SPEED
- TERMINATION EFFECTS
- COMPATIBLE WITH FAIRCHILD DTL, LPDTL, TTL, AND MSI FAMILIES

PIN NAMES

\bar{E}	Enable (Active LOW) Input
A_0, A_1, A_2, A_3, A_4	Word A Parallel Inputs
B_0, B_1, B_2, B_3, B_4	Word B Parallel Inputs
$A < B$	A Less Than B Output (Note b)
$A > B$	A Greater Than B Output (Note b)
$A = B$	A Equal to B Output (Note b)

Notes:

- 1 Unit Load (U.L.) = 40 μ A HIGH/1.6 mA LOW
- 10 U.L. is the output LOW drive factor and 20 U.L. is the output HIGH drive factor

LOADING

(Note a)
2 U.L.
2 U.L.
2 U.L.
10 U.L.
10 U.L.
10 U.L.

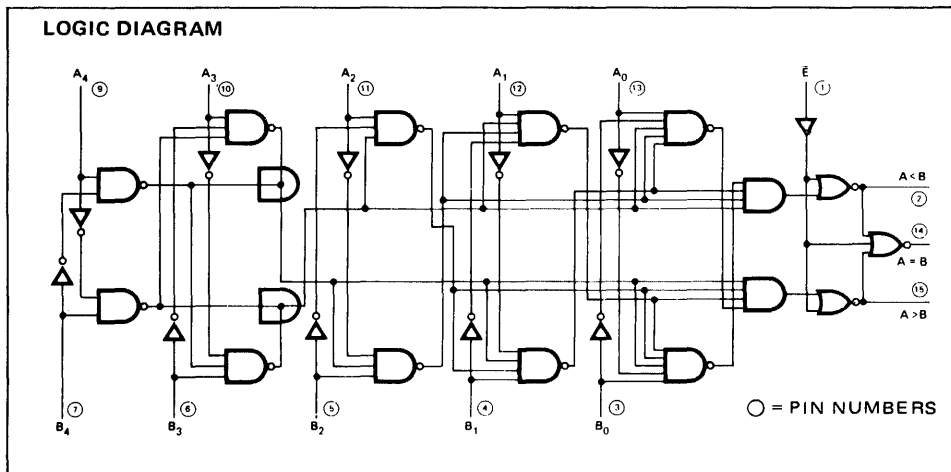

LOGIC SYMBOL

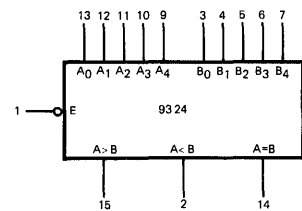

V_{CC} = Pin 16
GND = Pin 8

CONNECTION DIAGRAMS DIP (TOP VIEW)

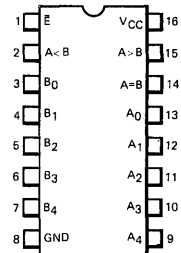

FLATPAK (TOP VIEW)

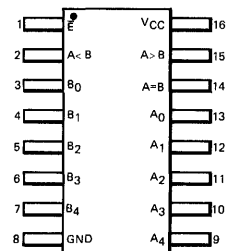

FUNCTIONAL DESCRIPTION — The 9324 5-bit comparator uses combinational circuitry to directly generate "A greater than B" and "A less than B" outputs. As evident from the logic diagram, these outputs are generated in only three gate delays. The "A equals B" output is generated in one additional gate delay by decoding the "A neither less than nor greater than B" condition with a NOR gate. All three outputs are activated by the active LOW Enable input (\bar{E}).

Tying the $A > B$ output from one device into an A input on another device and the $A < B$ output into the corresponding B input permits easy expansion.

The A_4 and B_4 inputs are the most significant inputs and A_0, B_0 the least significant. Thus if A_4 is HIGH and B_4 is LOW, the $A > B$ output will be HIGH regardless of all other inputs except \bar{E} .

TRUTH TABLE

\bar{E}	A_y	B_y	A < B	A > B	A = B
H	X	X	L	L	L
L	Word A = Word B		L	L	H
L	Word A > Word B		L	H	L
L	Word B > Word A		H	L	L

H = HIGH Voltage Level
 L = LOW Voltage Level
 X = Either HIGH or LOW Voltage Level

TYPICAL INPUT AND OUTPUT CHARACTERISTICS

INPUT EQUIVALENT CIRCUIT

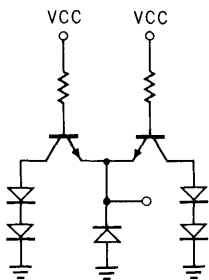

OUTPUT EQUIVALENT CIRCUIT (Output HIGH)

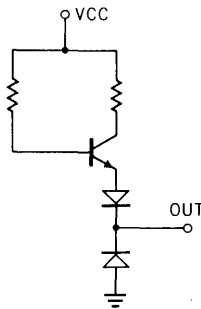

OUTPUT EQUIVALENT CIRCUIT (Output LOW)

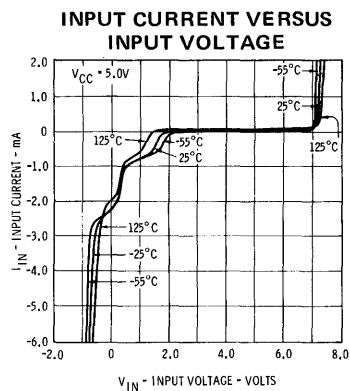
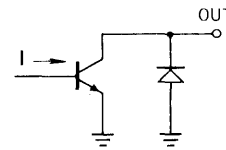

Fig. 1.

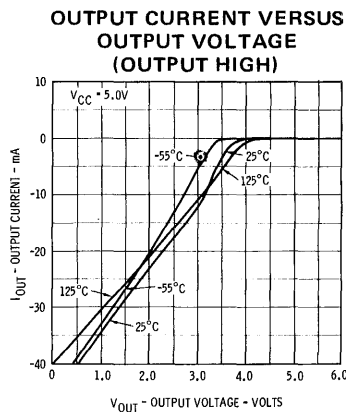

Fig. 2.

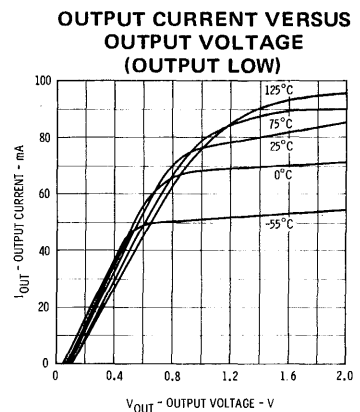

Fig. 3.

FAIRCHILD TTL/MSI • 9324

ABSOLUTE MAXIMUM RATINGS (above which the useful life may be impaired)

Storage Temperature	-65°C to +150°C
Temperature (Ambient) Under Bias	-55°C to +125°C
V _{CC} Pin Potential to Ground Pin	-0.5 V to +7.0 V
*Input Voltage (dc)	-0.5 V to +5.5 V
*Input Current (dc)	-30 mA to +5.0 mA
Voltage Applied to Outputs (Output HIGH)	-0.5 V to +V _{CC} value
Output Current (dc) (Output LOW)	+30 mA

*Either Input Voltage limit or Input Current limit is sufficient to protect the inputs.

GUARANTEED OPERATING RANGES

PART NUMBER	SUPPLY VOLTAGE (V _{CC})			TEMPERATURE
	MIN.	TYP.	MAX.	
9324XM	4.5 V	5.0 V	5.5 V	-55°C to 125°C
9324XC	4.75 V	5.0 V	5.25 V	0°C to 75°C

X = package type; F for Flatpak, D for Ceramic Dip, P for Plastic Dip. See Packaging Information Section for packages available on this product.

ELECTRICAL CHARACTERISTICS OVER OPERATING TEMPERATURE RANGE (unless otherwise noted)

SYMBOL	PARAMETER	LIMITS			UNITS	CONDITIONS
		MIN.	TYP. (Note 4)	MAX.		
V _{IH}	Input HIGH Voltage	2.0			Volts	Guaranteed Input HIGH Threshold Voltage for All Inputs
V _{IL}	Input LOW Voltage			0.8	Volts	Guaranteed Input LOW Threshold Voltage for All Inputs
V _{CD}	Input Clamp Diode Voltage			-1.5	Volts	V _{CC} = MIN., I _{IN} = -12mA, T _A = 25°C
V _{OH}	Output HIGH Voltage	2.4	3.6		Volts	V _{CC} = MIN., I _{OH} = -800 μA V _{IN} = V _{IH} or V _{IL} per Truth Table
V _{OL}	Output LOW Voltage		0.2	0.4	Volts	V _{CC} = MIN., I _{OL} = 16 mA V _{IN} = V _{IH} or V _{IL} per Truth Table
I _{IH}	Input HIGH Current		20	80	μA	V _{CC} = MAX., V _{IN} = 2.4 V
				1.0	mA	V _{CC} = MAX., V _{IN} = 5.0 V
I _{IL}	Input LOW Current		-1.92	-3.2	mA	V _{CC} = MAX., V _{IN} = 0.4 V
I _{SC} (I _{O5})	Output Short Circuit Current (Note 5)	-20	-50	-70	mA	V _{CC} = MAX., V _{OUT} = 0 V
I _{CC}	Power Supply Current		40	81	mA	V _{CC} = MAX.

NOTES:

- The actual testing procedures used to guarantee the Electrical Characteristics are contained in a detailed Customer Sample Specification. A copy of this specification can be obtained from Fairchild Digital Product Marketing, Mountain View, California.
- Conditions for testing, not shown in the table, are chosen to guarantee operation under "worst case" conditions.
- The specified LIMITS represent the "worst case" value for the parameter. Since these "worst case" values normally occur at the temperature and supply voltage extremes, additional noise immunity and guard banding can be achieved by decreasing the allowable system operating ranges.
- Typical limits are at V_{CC} = 5.0 V, 25°C, and maximum loading.
- Not more than one output should be shorted at a time.

SWITCHING CHARACTERISTICS (T_A = 25°C)

SYMBOL	PARAMETER	9324XM			9324XC			UNITS	CONDITIONS
		MIN.	TYP.	MAX.	MIN.	TYP.	MAX.		
t _{PLH}	Turn Off Delay Input to Output (A ₂ to A = B)		40	45		40	48	ns	V _{CC} = 5.0 V C _L = 15 pF
t _{PHL}	Turn On Delay Input to Output (A ₂ to A = B)		35	42		35	45	ns	

SWITCHING CHARACTERISTICS

$t_{PLH}/t_{PHL} - \bar{E} \text{ to } A = B$

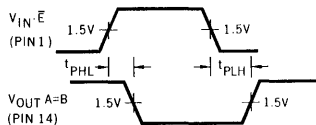

Other Conditions:
All Other Inputs HIGH

$t_{PLH}/t_{PHL} - A_2 \text{ to } A > B$

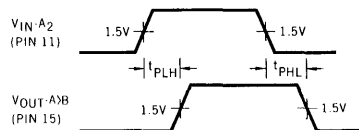

Other Conditions: Pin 1, 5 = GND
All Other Inputs HIGH

TURN OFF DELAY TIME
VERSUS
AMBIENT TEMPERATURE
($\bar{E} \text{ to } A = B$)

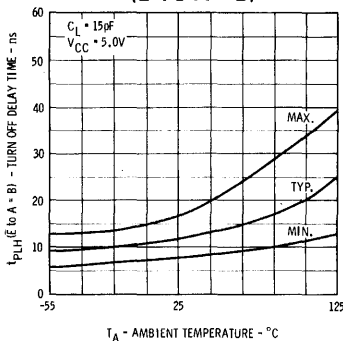

TURN ON DELAY TIME
VERSUS
AMBIENT TEMPERATURE
($\bar{E} \text{ to } A = B$)

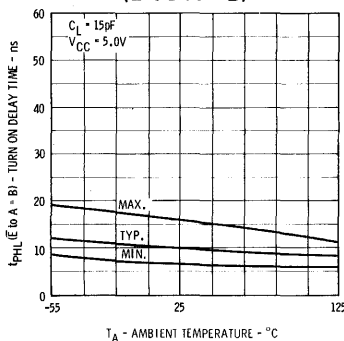
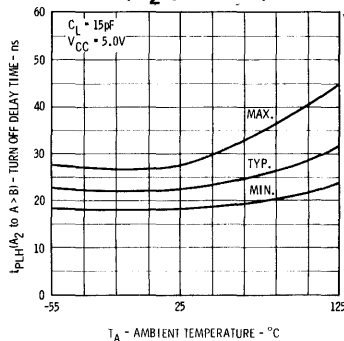

Fig. 4.

TURN OFF DELAY TIME
VERSUS
AMBIENT TEMPERATURE
($A_2 \text{ to } A > B$)



TURN ON DELAY TIME
VERSUS
AMBIENT TEMPERATURE
($A_2 \text{ to } A > B$)

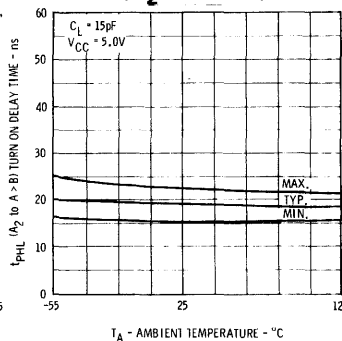
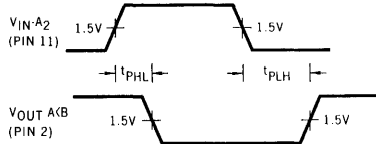

Fig. 5.

$t_{PLH}/t_{PHL} - A_2 \text{ to } A < B$



Other Conditions: Pin 1 = GND
All Other Inputs HIGH

$t_{PLH}/t_{PHL} - A_2 \text{ to } A = B$

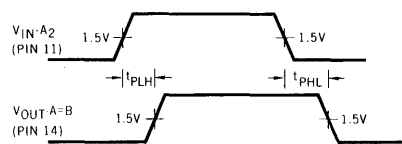

Other Conditions: Pin 1 = GND
All Other Inputs HIGH

TURN OFF DELAY TIME
VERSUS
AMBIENT TEMPERATURE
($A_2 \text{ to } A < B$)

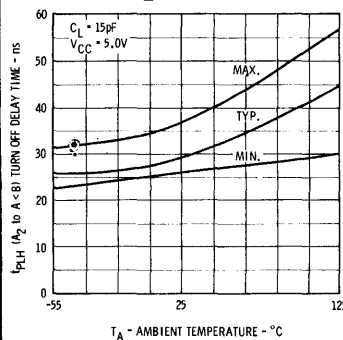

TURN ON DELAY TIME
VERSUS
AMBIENT TEMPERATURE
($A_2 \text{ to } A < B$)

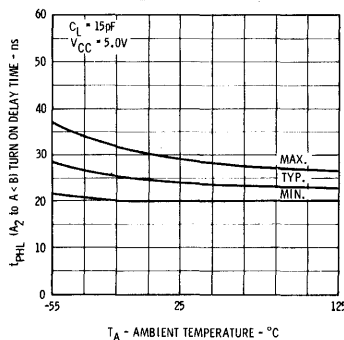
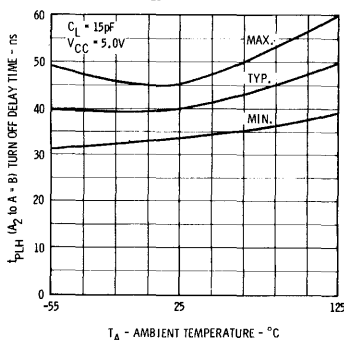

Fig. 6

TURN OFF DELAY TIME
VERSUS
AMBIENT TEMPERATURE
($A_2 \text{ to } A = B$)



TURN ON DELAY TIME
VERSUS
AMBIENT TEMPERATURE
($A_2 \text{ to } A = B$)

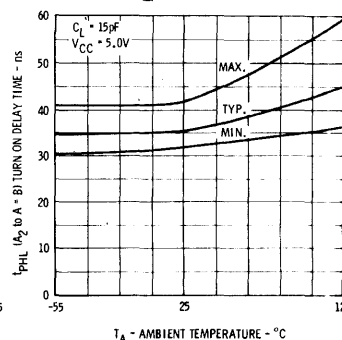

Fig. 7.

LPTTL/MSI 93L24

LOW POWER 5-BIT COMPARATOR

DESCRIPTION — The LPTTL/MSI 93L24 is a Medium Speed Expandable Comparator which provides comparison between two 5-bit words and gives three outputs, "less than", "greater than", and "equal to". A HIGH level on the active LOW enable input forces all three outputs LOW.

- THREE SEPARATE OUTPUTS . . . $A < B$, $A > B$, $A = B$
- EASILY EXPANDABLE
- ACTIVE LOW-LEVEL ENABLE INPUT
- HIGH DRIVE OUTPUT CIRCUITRY
- TYPICAL PROPAGATION DELAY OF 55 ns ($A > B$)
- TYPICAL POWER DISSIPATION OF 52 mW
- INPUT CLAMP DIODES LIMIT HIGH SPEED TERMINATION EFFECTS
- ALL CERAMIC "HERMETIC" 16-LEAD DUAL IN-LINE AND FLAT PACKAGES
- TTL COMPATIBLE

PIN NAMES

\bar{E}	Enable (Active LOW) Input
A_0, A_1, A_2, A_3, A_4	Word A Parallel Inputs
B_0, B_1, B_2, B_3, B_4	Word B Parallel Inputs
$A < B$	A Less than B Output
$A > B$	A Greater than B Output
$A = B$	A Equal to B Output

LOADING

	HIGH	LOW
1.0 U.L.	1.0 U.L.	0.5 U.L.
1.0 U.L.	1.0 U.L.	0.5 U.L.
1.0 U.L.	1.0 U.L.	0.5 U.L.
9 U.L.	2.25 U.L.	
9 U.L.	2.25 U.L.	
10 U.L.	2.5 U.L.	

1 Unit Load (U.L.) = 40 μ A HIGH/1.6mA LOW.

LOGIC SYMBOL

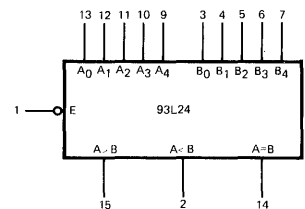

V_{CC} = Pin 16
GND = Pin 8

CONNECTION DIAGRAMS DIP (TOP VIEW)

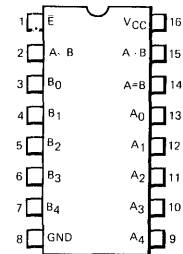

FLATPAK (TOP VIEW)

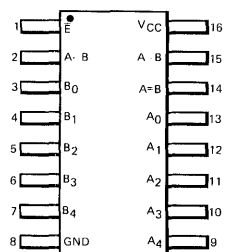

LOGIC DIAGRAM

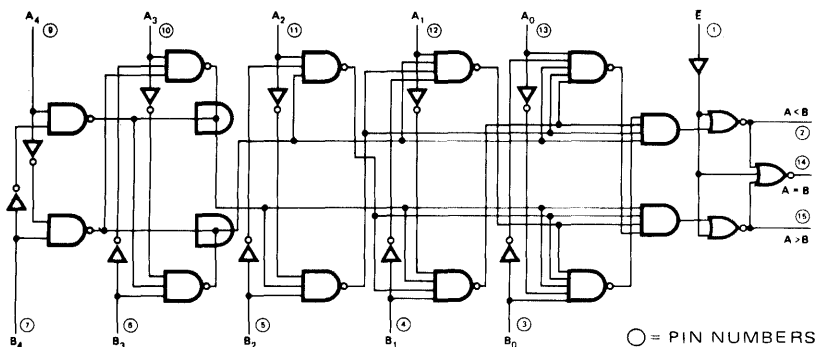

FAIRCHILD LPTTL/MSI •93L24

FUNCTIONAL DESCRIPTION — The 93L24 5-bit comparator uses combinational circuitry to directly generate "A greater than B" and "A less than B" outputs. As evident from the logic diagram, these outputs are generated in only three gate delays. The "A equals B" output is generated in one additional gate delay by decoding the "A neither less than nor greater than B" condition with a NOR gate. All three outputs are activated by the active LOW enable input (\bar{E}).

Tying the A > B output from one device into an A input on another device and the A < B output into the corresponding B input permits easy expansion as shown in Figure 1.

The A₄ and B₄ inputs are the most significant inputs and A₀, B₀ the least significant. Thus if A₄ is HIGH and B₄ is LOW, the A > B output will be HIGH regardless of all other inputs except \bar{E} .

TRUTH TABLE

\bar{E}	A	B	A < B	A > B	A = B
H	X	X	L	L	L
L	Word A = Word B		L	L	H
L	Word A > Word B		L	H	L
L	Word A < Word B		H	L	L

L = LOW Voltage Level
 H = HIGH Voltage Level
 X = Either HIGH or LOW Voltage Level

TYPICAL INPUT AND OUTPUT CIRCUITS

INPUTS EQUIVALENT CIRCUIT

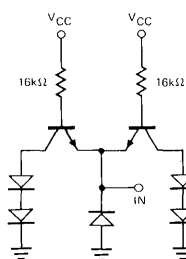

OUTPUTS EQUIVALENT CIRCUITS

OUTPUT HIGH

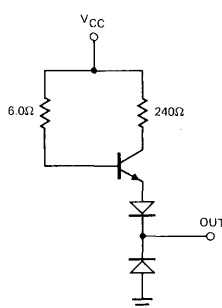

OUTPUT LOW

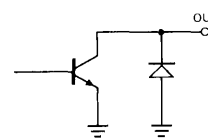

ABSOLUTE MAXIMUM RATINGS (above which the useful life may be impaired)

Storage Temperature	-65°C to +150°C
Temperature (Ambient) Under Bias	-55°C to +125°C
V _{CC} Pin Potential to Ground Pin	-0.5 V to +7.0 V
*Input Voltage (dc)	-0.5 V to +5.5 V
*Input Current (dc)	-30 mA to +5.0 mA
Voltage Applied to Outputs (Output HIGH)	-0.5 V to +V _{CC} value
Output Current (dc) (Output LOW)	+30 mA

*Either Input Voltage limit or Input Current limit is sufficient to protect the inputs.

GUARANTEED OPERATING RANGES

PART NUMBER	SUPPLY VOLTAGE (V _{CC})			TEMPERATURE
	MIN.	TYP.	MAX.	
93L24XM	4.5 V	5.0 V	5.5 V	-55°C to 125°C
93L24XC	4.75 V	5.0 V	5.25 V	0°C to 75°C

X = package type; F for Flatpak, D for Ceramic Dip, P for Plastic Dip. See Packaging Information Section for packages available on this product.

FAIRCHILD LPTTL/MSI • 93L24

ELECTRICAL CHARACTERISTICS OVER OPERATING TEMPERATURE RANGE (unless otherwise noted)

SYMBOL	PARAMETER	LIMITS			UNITS	CONDITIONS
		MIN.	TYP. (Note 4)	MAX.		
V _{OH}	Output HIGH Voltage	2.4	3.6		Volts	V _{CC} =MIN., I _{OH} = -0.4mA (Pin 14), I _{OH} = -0.36mA (Pin 2&15), V _{IN} =V _{IH} or V _{IL} per Truth Table
V _{OL}	Output LOW Voltage		0.15	0.3	Volts	V _{CC} = MIN., I _{OL} = 4.0 mA (Pin 14) I _{OL} = 3.6 mA (Pins 2 & 15) V _{IN} = V _{IH} or V _{IL} per Truth Table
V _{IH}	Input HIGH Voltage	2.0			Volts	Guaranteed Input HIGH Threshold Voltage for All Inputs
V _{IL}	Input LOW Voltage			0.7	Volts	Guaranteed Input LOW Threshold Voltage for All Inputs
I _{IL}	Input LOW Current		-0.5	-0.8	mA	V _{CC} = MAX., V _{IN} = 0.3 V
I _{IH}	Input HIGH Current		4.0	40	μA	V _{CC} = MAX., V _{IN} = 2.4 V
				1.0	mA	V _{CC} = MAX., V _{IN} = 5.5 V
I _{SC}	Output Short Circuit Current (Note 5)	-10	-22	-40	mA	V _{CC} = MAX., V _{OUT} = 0 V
I _{CC}	Power Supply Current		10.4	21	mA	V _{CC} = MAX.

NOTES:

1. The actual testing procedures used to guarantee the Electrical Characteristics are contained in a detailed Customer Sample Specification. A copy of this specification can be obtained from Fairchild Digital Product Marketing, Mountain View, California.
2. Conditions for testing, not shown in the table, are chosen to guarantee operation under "worst case" conditions.
3. The specified LIMITS represent the "worst case" value for the parameter. Since these "worst case" values normally occur at the temperature and supply voltage extremes, additional noise immunity and guard banding can be achieved by decreasing the allowable system operating ranges.
4. Typical limits are at V_{CC} = 5.0 V, 25°C, and maximum loading.
5. Not more than one output should be shorted at a time.

SWITCHING CHARACTERISTICS (T_A = 25°C)

SYMBOL	PARAMETER	LIMITS			UNITS	CONDITIONS
		MIN.	TYP.	MAX.		
t _{PLH}	Enable to Output (\bar{E} to A = B)		21	32	ns	C _L = 15 pF V _{CC} = 5.0 V
t _{PHL}	(\bar{E} to A = B)		22	35	ns	
t _{PLH}	Data to Output (A ₂ to A > B)		35	54	ns	
t _{PHL}	(A ₂ to A > B)		50	75	ns	
t _{PLH}	Data to Output (A ₂ to A < B)		46	70	ns	
t _{PHL}	(A ₂ to A < B)		51	77	ns	
t _{PLH}	Data to Output (A ₂ to A = B)		65	100	ns	
t _{PHL}	(A ₂ to A = B)		68	102	ns	

SERIAL EXPANSION OF 93L24 FOR LONGER WORD LENGTHS

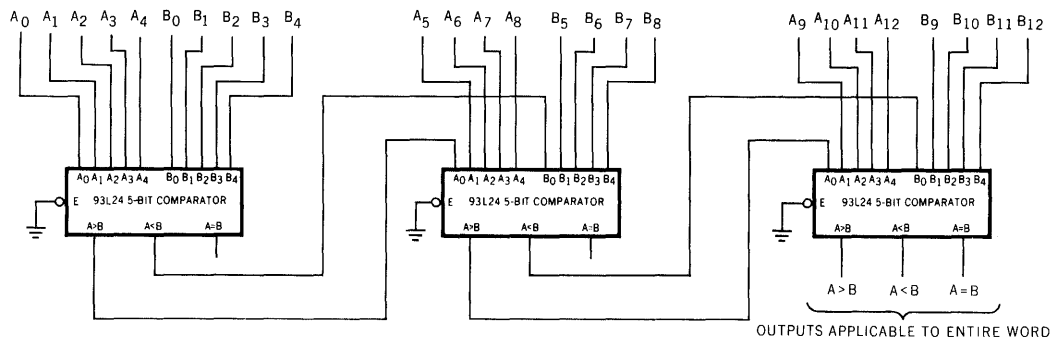

For each additional 93L24 added four extra bits can be accommodated.

Fig. 1.

TTL/MSI 9328

DUAL 8-BIT SHIFT REGISTER

DESCRIPTION — The 9328 is a high speed serial storage element providing 16 bits of storage in the form of two 8-bit registers that will shift at greater than 20 MHz rates. The multi-functional capability of this device is provided by several features: 1) Additional gating is provided at the input to both shift registers so that the input is easily multiplexed between two sources. 2) The clock of each register may be provided separately or together. 3) Both the true and complementary outputs are provided from each 8-bit register, and both registers may be master cleared from a common input.

- 20 MHz SHIFT FREQUENCY
- TWO INPUT MULTIPLEXER PROVIDED AT DATA INPUT OF EACH REGISTER
- GATED CLOCK INPUT CIRCUITRY
- BOTH TRUE AND COMPLEMENTARY OUTPUTS PROVIDED FROM LAST BIT OF EACH REGISTER
- ASYNCHRONOUS MASTER RESET COMMON TO BOTH REGISTERS
- TYPICAL POWER DISSIPATION OF 300 mW
- TTL COMPATIBLE
- INPUT DIODE CLAMPING

PIN NAMES

D _S	Data Select Input
D ₀ , D ₁	Data Inputs
CP	Clock (Active HIGH) Going Edge Input
	Common (Pin 9)
	Separate (Pins 7 and 10)
\overline{MR}	Master Reset (Active LOW) Input
Q ₇	Last Stage Output (Note b)
$\overline{Q_7}$	Complementary Output (Note b)

LOADING
(Note a)

2 U.L.
1 U.L.
3 U.L.
1.5 U.L.
1 U.L.
10 U.L.
10 U.L.

NOTES

- a. 1 Unit Load (U.L.) = 40 μ A HIGH/1.6 mA LOW
 b. 10 U.L. is the output LOW drive factor and 20 U.L. is the output HIGH drive factor

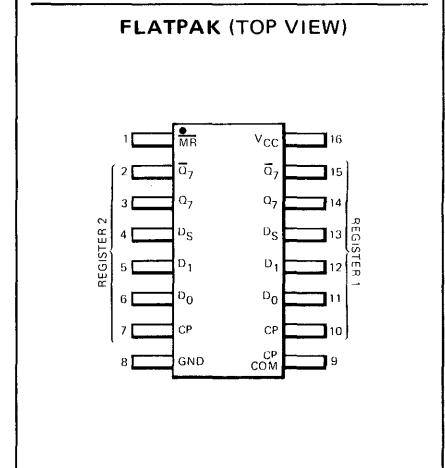
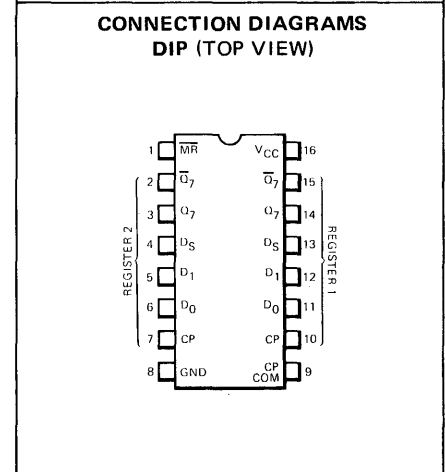
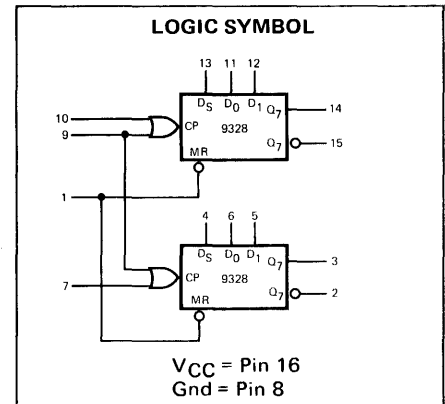
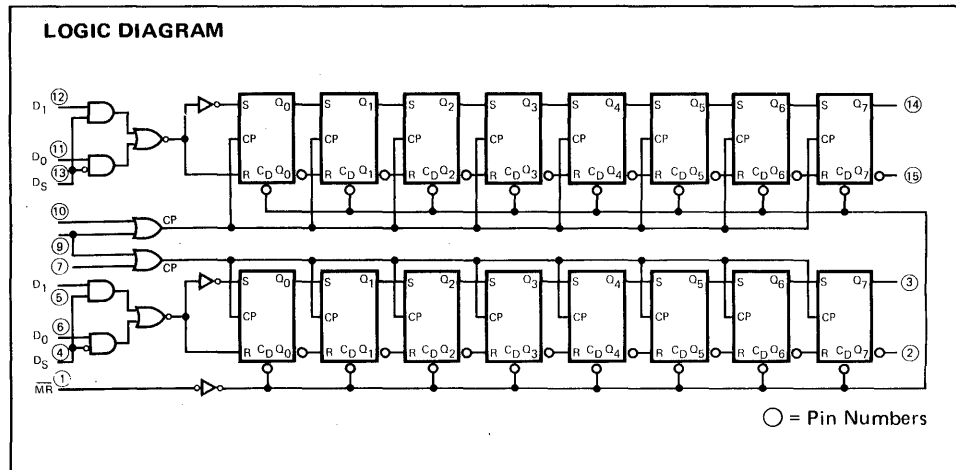

FUNCTIONAL DESCRIPTION — The two 8-bit shift registers have a common clock input (pin 9) and separate clock inputs (pins 10 and 7). The clocking of each register is controlled by the OR function of the separate and the common clock input. Each register is composed of eight clocked RS master/slave flip-flops and a number of gates. The clock OR gate drives the eight clock inputs of the flip-flops in parallel. When the two clock inputs (the separate and the common) to the OR gate are LOW, the slave latches are steady, but data can enter the master latches via the R and S input. During the first LOW to HIGH transition of either, or both simultaneously, of the two clock inputs, the data inputs (R and S) are inhibited so that a later change in input data will not affect the master; then the now trapped information in the master is transferred to the slave. When the transfer is complete, both the master and the slave are steady as long as either or both clock inputs remain HIGH. During the HIGH to LOW transition of the last remaining HIGH clock input, the transfer path from master to slave is inhibited first, leaving the slave steady in its present state. The data inputs (R and S) are enabled so that new data can enter the master. Either of the clock inputs can be used as clock inhibit inputs by applying a logic HIGH signal. Each 8-bit shift register has a two input multiplexer in front of the serial data input. The two data inputs D_0 and D_1 are controlled by the data select input (D_S) following the Boolean expression:

$$\text{Serial data in: } S_D = \bar{D}_S D_0 + D_S D_1$$

An asynchronous master reset is provided which, when activated by a LOW logic level, will clear all sixteen stages independently of any other input signal.

TRUTH TABLE

SHIFT SELECTION

D_S	D_0	D_1	$Q_7 (t_{n+8})$
L	L	X	L
L	H	X	H
H	X	L	L
H	X	H	H

n+8 = Indicates state after eight clock pulse
 L = LOW voltage level
 H = HIGH voltage level
 X = Either HIGH or LOW voltage level

ABSOLUTE MAXIMUM RATINGS (above which the useful life may be impaired)

Storage Temperature	-65°C to +150°C
Temperature (Ambient) Under Bias	-55°C to +125°C
V_{CC} Pin Potential to Ground Pin	-0.5 V to +7.0 V
*Input Voltage (dc)	-0.5 V to +5.5 V
*Input Current (dc)	-30 mA to +5.0 mA
Voltage Applied to Outputs (Output HIGH)	-0.5 V to + V_{CC} value
Output Current (dc) (Output LOW)	+30 mA

*Either Input Voltage limit or Input Current limit is sufficient to protect the inputs.

GUARANTEED OPERATING RANGES

PART NUMBER	SUPPLY VOLTAGE (V_{CC})			TEMPERATURE
	MIN.	TYP.	MAX.	
9328XM	4.5 V	5.0 V	5.5 V	-55°C to 125°C
9328XC	4.75 V	5.0 V	5.25 V	0°C to 75°C

X = package type; F for Flatpak, D for Ceramic Dip, P for Plastic Dip. See Packaging Information Section for packages available on this product.

ELECTRICAL CHARACTERISTICS OVER OPERATING TEMPERATURE RANGE (Unless otherwise noted)

SYMBOL	PARAMETER	LIMITS			UNITS	CONDITIONS
		MIN.	TYP. (Note 4)	MAX.		
V _{IH}	Input HIGH Voltage	2.0			Volts	Guaranteed Input HIGH Threshold Voltage for All Inputs
V _{IL}	Input LOW Voltage			0.8	Volts	Guaranteed Input LOW Threshold Voltage for All Inputs
V _{CD}	Input Clamp Diode Voltage			-1.5	Volts	V _{CC} = MIN., I _{IN} = -12 mA, T _A = 25°C
V _{OH}	Output HIGH Voltage	2.4	3.6		Volts	V _{CC} = MIN., I _{OH} = -800 μA V _{IN} = V _{IH} or V _{IL} per Truth Table
V _{OL}	Output LOW Voltage		0.2	0.4	Volts	V _{CC} = MIN., I _{OL} = 16 mA V _{IN} = V _{IH} or V _{IL} per Truth Table
I _{IH}	Input HIGH Current MR, D ₀ , D ₁ CP (Pins 7 & 10)		10 15	40 60	μA	V _{CC} = MAX., V _{IN} = 2.4 V
	D _S CP (Pin 9)		20 30	80 120		
	Input HIGH Current all inputs			1.0	mA	V _{CC} = MAX., V _{IN} = 5.0 V
I _{IL}	Input LOW Current MR, D ₀ , D ₁ CP (Pins 7 & 10)		-0.96 -1.44	-1.6 -2.4	mA	V _{CC} = MAX., V _{IN} = 0.4 V
	D _S CP (Pin 9)		-1.92 -2.88	-3.2 -4.8		
I _{SC} (I _{OS})	Output Short Circuit Current (Note 5)	-20	-50	-70	mA	V _{CC} = MAX., V _{OUT} = 0.0 V
I _{CC}	Power Supply Current		60	77	mA	V _{CC} = MAX.

NOTES:

1. The actual testing procedures used to guarantee the Electrical Characteristics are contained in a detailed Customer Sample Specification. A copy of this specification can be obtained from Fairchild Digital Product Marketing, Mountain View, California.
2. Conditions for testing, not shown in the table, are chosen to guarantee operation under "worst case" conditions.
3. The specified LIMITS represent the "worst case" value for the parameter. Since these "worst case" values normally occur at the temperature and supply voltage extremes, additional noise immunity and guard banding can be achieved by decreasing the allowable system operating ranges.
4. Typical limits are at V_{CC} = 5.0 V, 25°C, and maximum loading.
5. Not more than one output should be shorted at a time.

SWITCHING CHARACTERISTICS (T_A = 25°C)

SYMBOL	PARAMETER	LIMITS			UNITS	TEST CONDITIONS	
		MIN.	TYP.	MAX.			
t _{PLH}	Turn Off Delay Clock to Output		13	20	ns	Fig. 1	V _{CC} = 5.0 V C _L = 15 pF
t _{PHL}	Turn On Delay Clock to Output		22	35	ns		
t _{PHL}	Turn On Delay Master Reset to Q Output		35	50	ns		
f _{sr}	Shift Right Frequency	20	30		MHz	Fig. 1	

SWITCHING SET-UP REQUIREMENTS (T_A = 25°C)

SYMBOL	PARAMETER	LIMITS			UNITS	TEST CONDITIONS	
		MIN.	TYP.	MAX.			
t _{pw} (CP)	Clock Pulse Width	25	17		ns	Fig. 1	V _{CC} = 5.0 V
t _{pw} (MR) (CPH)	Master Reset Pulse Width with Clock HIGH	30	20		ns	Fig. 2	
t _{pw} (MR) (CPL)	Master Reset Pulse Width with Clock LOW	40	24		ns		
t _s (Data)	Set-up Time Data to Clock	20	10		ns	Fig. 3	
t _h (Data)	Hold Time Data to Clock	0			ns		
t _{rec} (MR)	Recovery Time Master Reset to Clock	33	19		ns	Fig. 2	

SET-UP TIME (t_s) is defined as the minimum time required for the correct logic level to be present at the logic input prior to the clock transition from LOW to HIGH in order to be recognized and transferred to the outputs.

HOLD TIME (t_h) is defined as the minimum time following the clock transition from LOW to HIGH that the logic level must be maintained at the input in order to insure continued recognition. A negative Hold Time indicates that the correct logic level may be released prior to the clock transition from LOW to HIGH and still be recognized.

RECOVERY TIME (t_{rec}) is defined as the minimum time required between the end of the reset pulse and the clock transition from LOW to HIGH in order to recognize and transfer HIGH Data to the Q outputs.

SWITCHING WAVEFORMS

CLOCK TO OUTPUT DELAYS AND MINIMUM CLOCK PULSE WIDTH

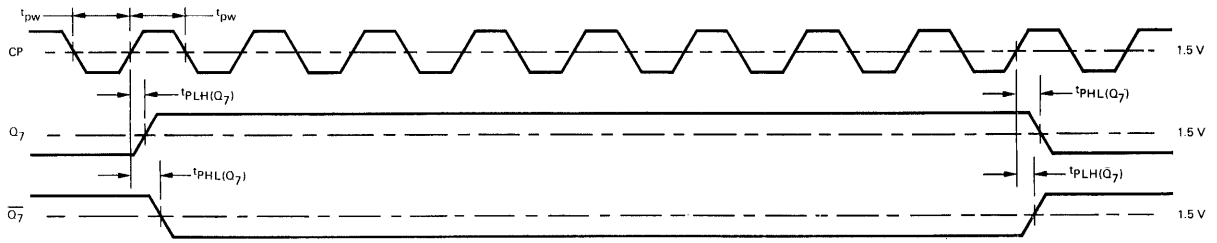

OTHER CONDITIONS: \bar{Q}_7 is connected to D_1 . Other clock is LOW.

Fig. 1

MASTER RESET TO OUTPUT TURN ON DELAY AND MINIMUM MASTER RESET PULSE WIDTHS

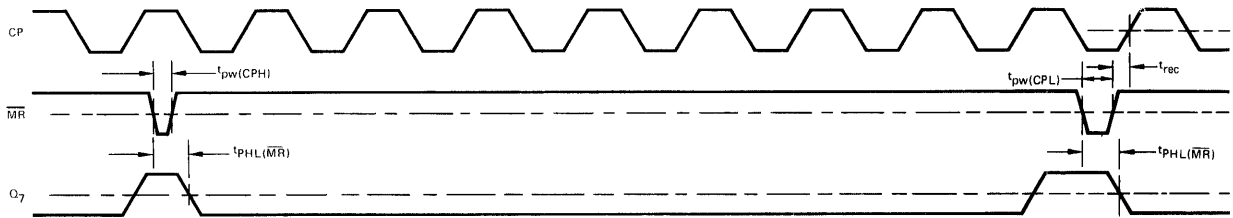

OTHER CONDITIONS: D_S, D_1, D_0 are HIGH. Other clock input is LOW.

Fig. 2

SET-UP TIME (t_s) AND HOLD TIME (t_h) FOR DATA INPUTS

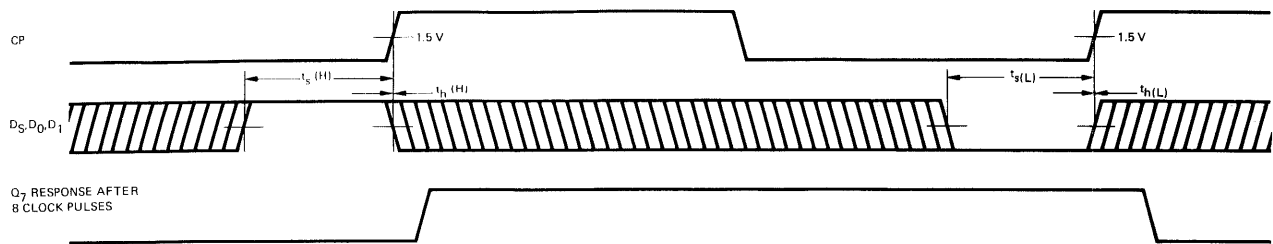

NOTE: The shaded areas indicate when the input is permitted to change for predictable output performance.

OTHER CONDITIONS: \bar{MR} = HIGH, other clock input is LOW.

Fig. 3

LPTTL/MSI 93L28

LOW POWER DUAL 8-BIT SHIFT REGISTER

DESCRIPTION — The LPTTL/MSI 93L28 is a medium speed Serial Storage Element providing sixteen bits of storage in the form of two 8-bit registers that will shift at greater than 5 MHz rates. The multi-functional capability of this device is provided by several features: 1) Additional gating is at the input to both shift registers so that the input is easily multiplexed between two sources. 2) The clock of each register may be provided separately or together. 3) Both the true and complementary outputs are provided from each 8-bit register, and both registers may be master reset from a common input.

- 10 MHz TYPICAL SHIFT FREQUENCY
- TWO-INPUT MULTIPLEXER PROVIDED AT DATA INPUT OF EACH REGISTER
- GATED CLOCK INPUT CIRCUITRY
- BOTH TRUE AND COMPLEMENTARY OUTPUTS PROVIDED FROM LAST BIT OF EACH REGISTER
- ASYNCHRONOUS MASTER RESET COMMON TO BOTH REGISTERS
- TYPICAL POWER DISSIPATION OF 80 mW
- INPUT CLAMP DIODES LIMIT HIGH SPEED TERMINATION EFFECTS
- ALL CERAMIC "HERMETIC" 16-LEAD DUAL IN-LINE AND FLAT PACKAGES
- TTL COMPATIBLE

PIN NAMES

D_S	Data Select Input
D_0, D_1	Data Inputs
CP	Clock (Active HIGH Going Edge) Input
	Common
	Separate
\overline{MR}	Master Reset (Active LOW) Input
Q_7	Last Stage Output
\overline{Q}_7	Complementary Output

1 Unit Load (U.L.) = 40 μ A HIGH/1.6 mA LOW.

LOADING

	HIGH	LOW
D_S	1.0 U.L.	0.5 U.L.
D_0, D_1	0.5 U.L.	0.25 U.L.
CP	1.5 U.L.	0.75 U.L.
\overline{MR}	0.75 U.L.	0.375 U.L.
Q_7	8.0 U.L.	2.0 U.L.
\overline{Q}_7	8.0 U.L.	2.0 U.L.

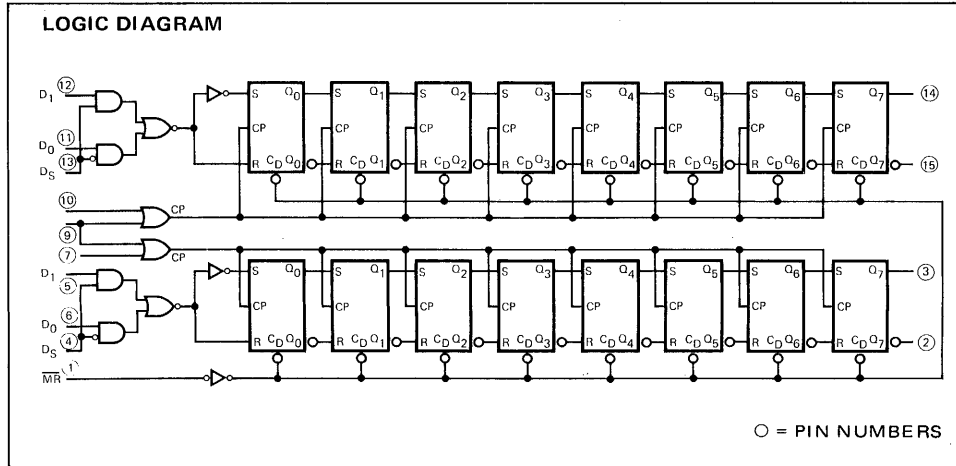
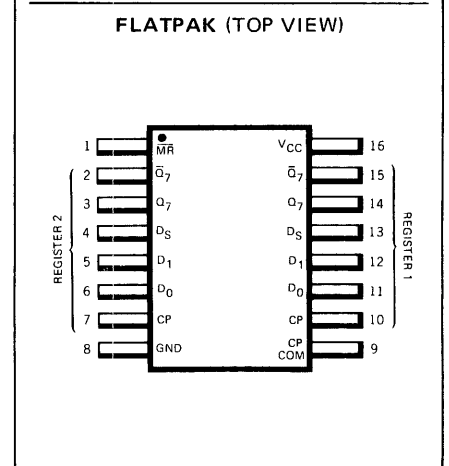
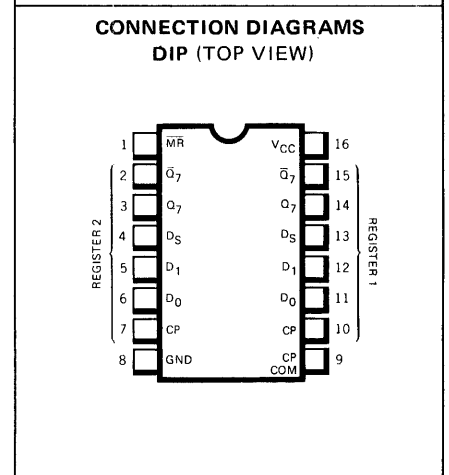
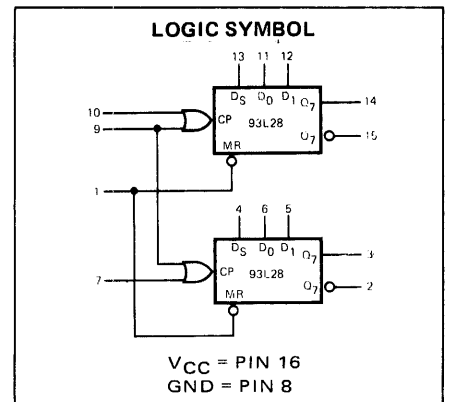

FAIRCHILD LPTTL/MSI • 93L28

FUNCTIONAL DESCRIPTION — The two 8-bit shift registers have a common clock input (pin 9) and separate clock inputs (pins 10 & 7). The clocking of each register is controlled by the OR function of the separate and the common clock input. Each register is composed of eight clocked RS master/slave flip-flops and a number of gates. The clock OR gate drives the eight clock inputs of the flip-flops in parallel. When the two clock inputs (the separate and the common) to the OR gate are LOW, the slave latches are steady, but data can enter the master latches via the R and S input. During the first LOW to HIGH transition of either or both of the two clock inputs, the data inputs (R and S) are inhibited so that a later change in input data will not affect the master. The now trapped information in the master is transferred to the slave. When the transfer is complete, both the master and the slave are steady as long as either or both clock inputs remain HIGH. During the HIGH to LOW transition of the last remaining high clock input, the transfer path from master to slave is inhibited first, leaving the slave steady in its present state. The data inputs (R and S) are enabled so that new data can enter the master. Either of the clock inputs can be used as clock inhibit inputs by applying a logic HIGH signal. Each 8-bit shift register has a two-input multiplexer in front of the serial data input. The two data inputs D_0 and D_1 are controlled by the data select input D_S following the Boolean expression:

$$\text{Serial data in: } S_D = \bar{D}_S D_0 + D_S D_1.$$

An asynchronous master reset is provided which, when activated by a LOW logic level, will clear all sixteen stages independently of any other input signal.

TRUTH TABLE

SHIFT SELECTION

D_S	D_0	D_1	$Q_7(t_{n+8})$
L	L	X	L
L	H	X	H
H	X	L	L
H	X	H	H

$n+8$ = indicates state after eight clock pulse
 L = LOW voltage level
 H = HIGH voltage level
 X = Either HIGH or LOW voltage level

ABSOLUTE MAXIMUM RATINGS (above which the useful life may be impaired)

Storage Temperature	-65°C to +150°C
Temperature (Ambient) Under Bias	-55°C to +125°C
V_{CC} Pin Potential to Ground Pin	-0.5 V to +7.0 V
*Input Voltage (dc)	-0.5 V to +5.5 V
*Input Current (dc)	-30 mA to +5.0 mA
Voltage Applied to Outputs (Output HIGH)	-0.5 V to + V_{CC} value
Output Current (dc) (Output LOW)	+30 mA

*Either Input Voltage limit or Input Current limit is sufficient to protect the inputs.

GUARANTEED OPERATING RANGES

PART NUMBER	SUPPLY VOLTAGE (V_{CC})			TEMPERATURE
	MIN.	TYP.	MAX.	
93L28XM	4.5V	5.0V	5.5V	-55°C to 125°C
93L28XC	4.75V	5.0V	5.25V	0°C to 75°C

X = package type; F for Flatpak, D for Ceramic Dip, P for Plastic Dip. See Packaging Information Section for packages available on this product.

FAIRCHILD LPTTL/MSI • 93L28

ELECTRICAL CHARACTERISTICS OVER OPERATING TEMPERATURE RANGE (Unless Otherwise Noted)

SYMBOL	PARAMETER	LIMITS			UNITS	CONDITIONS
		MIN.	TYP. (Note 4)	MAX.		
V _{OH}	Output HIGH Voltage	2.4	3.6		Volts	V _{CC} = MIN., I _{OH} = -0.32 mA V _{IN} = V _{IH} or V _{IL} per Truth Table
V _{OL}	Output LOW Voltage		0.15	0.3	Volts	V _{CC} = MIN., I _{OL} = 3.2 mA V _{IN} = V _{IH} or V _{IL} per Truth Table
V _{IH}	Input HIGH Voltage	2.0			Volts	Guaranteed Input HIGH Voltage For All Inputs
V _{IL}	Input LOW Voltage			0.7	Volts	Guaranteed Input LOW Voltage For All Inputs
I _{IL}	Input LOW Current				mA	V _{CC} = MAX., V _{IN} = 0.3 V
	\overline{MR} , D ₀ & D ₁		-0.25	-0.4		
	CP (Pins 7 & 10)		-0.38	-0.6		
	D _S CP (Pin 9)		-0.50 -0.75	-0.8 -1.2		
I _{IH}	Input HIGH Current				μ A	V _{CC} = MAX., V _{IN} = 2.4 V
	\overline{MR} , D ₀ & D ₁		2.0	20		
	CP (Pins 7 & 10)		3.0	30		
	D _S CP (Pin 9)		4.0 6.0	40 60		
	Input HIGH Current			1.0		
ISC (Note 5)	Output Short Circuit Current	-2.5	-16	-25	mA	V _{CC} = MAX., V _{OUT} = 0.0 V
I _{CC}	Power Supply Current		16	25.3	mA	V _{CC} = MAX.

NOTES:

1. The actual testing procedures used to guarantee the Electrical Characteristics are contained in a detailed Customer Sample Specification. A copy of this specification can be obtained from Fairchild Digital Product Marketing, Mountain View, California.
2. Conditions for testing, not shown in the table, are chosen to guarantee operation under "worst case" conditions.
3. The specified LIMITS represent the "worst case" value for the parameter. Since these "worst case" values normally occur at the temperature and supply voltage extremes, additional noise immunity and guard banding can be achieved by decreasing the allowable system operating ranges.
4. Typical limits are at V_{CC} = 5.0 V, 25°C, and maximum loading.
5. Not more than one output should be shorted at a time.

SWITCHING CHARACTERISTICS (T_A = 25°C)

SYMBOL	PARAMETER	MIN	TYP	MAX	UNITS	CONDITIONS
t _{PLH} (Q ₇ & \overline{Q} ₇)	Turn-Off Delay (clock to output)		30	45	ns	V _{CC} = 5.0V, C _L = 15pF Fig. 1
t _{PHL} (Q ₇ & \overline{Q} ₇)	Turn-On Delay (clock to output)		55	80	ns	
t _{PHL} (\overline{MR})	Turn-On Delay (Master reset to output)		72	110	ns	V _{CC} = 5.0V, C _L = 15pF,

SWITCHING SET-UP REQUIREMENTS (T_A = 25°C)

SYMBOL	PARAMETER	MIN	TYP	MAX	UNITS	CONDITIONS
t _{PW} CP	Min. Clock Pulse Width	55	30		ns	V _{CC} = 5.0V, C _L = 15pF Fig. 1
t _{PW} \overline{MR} (CPH)	Min. Master Reset Pulse Width with Clock HIGH	60	28		ns	V _{CC} = 5.0V, C _L = 15pF
t _{PW} \overline{MR} (CPL)	Min. Master Reset Pulse Width with Clock LOW	70	38		ns	V _{CC} = 5.0V, C _L = 15pF

SWITCHING WAVEFORMS

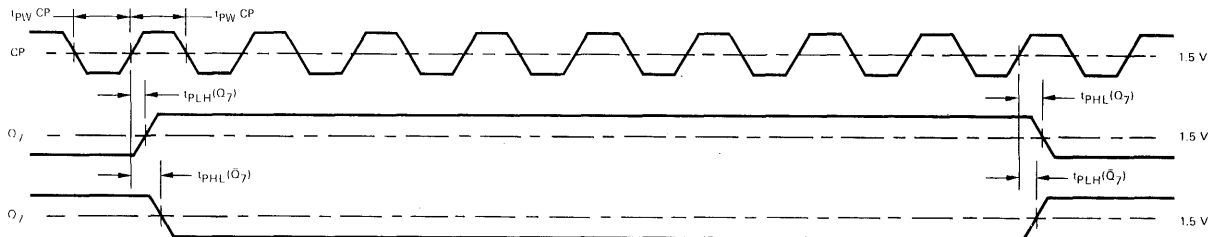

NOTE: \overline{Q} ₇ is connected to D₁. Other clock is grounded.

Fig. 1

TTL/MSI 9334

8-BIT ADDRESSABLE LATCH

DESCRIPTION — The TTL/MSI 9334 is a high speed 8-Bit Addressable Latch designed for general purpose storage applications in digital systems. It is a multifunctional device capable of storing single line data in eight addressable latches, and being a one-of-eight decoder and demultiplexer with active level HIGH outputs. The device also incorporates an active level LOW common clear for resetting all latches, as well as, an active level LOW enable. The 9334 is compatible with all members of Fairchild's TTL family.

- SERIAL TO PARALLEL CAPABILITY
- 8-BITS OF STORAGE WITH OUTPUT OF EACH BIT AVAILABLE
- RANDOM (ADDRESSABLE) DATA ENTRY
- ACTIVE HIGH DEMULTIPLEXING OR DECODING CAPABILITY
- EASILY EXPANDABLE
- COMMON CLEAR
- INPUT CLAMP DIODES LIMIT HIGH SPEED TERMINATION EFFECTS
- TTL COMPATIBLE

PIN NAMES

A_0, A_1, A_2	Address Inputs
D	Data Input
\bar{E}	Enable (Active LOW) Input
\bar{C}	Clear (Active LOW) Input
Q_0 to Q_7	Parallel Latch Outputs (Note b)

LOADING (Note a)
1 U.L.
1 U.L.
†1.5 U.L.
1 U.L.
6 U.L.

NOTES:

- 1 Unit Load (U.L.) = 40 μ A HIGH/1.6 mA LOW[†]
- 6 U.L. is the output LOW drive factor and 18 U.L. is the output HIGH drive factor.

LOGIC DIAGRAM

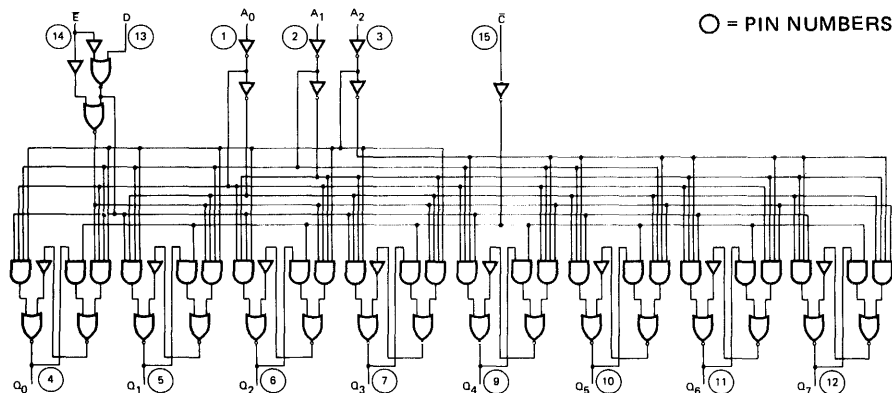

LOGIC SYMBOL

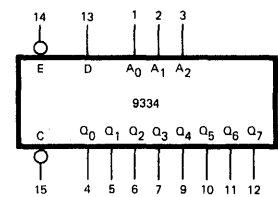

V_{CC} = Pin 16
GND = Pin 8

CONNECTION DIAGRAMS DIP (TOP VIEW)

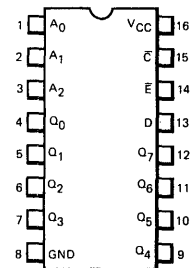

FLATPAK (TOP VIEW)

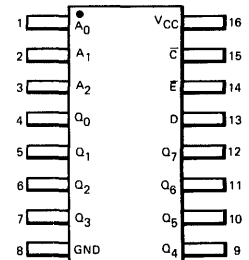

FAIRCHILD TTL/MSI • 9334

FUNCTIONAL DESCRIPTION — The TTL/MSI 9334 has four modes of operation which are shown in the mode selection table. In the addressable latch mode, data on the data line (D) is written into the addressed latch. The addressed latch will follow the data input with all non-addressed latches remaining in their previous states. In the memory mode, all latches remain in their previous state and are unaffected by the data or address inputs.

In the one-of-eight decoding or demultiplexing mode, the addressed output will follow the state of the D input with all other outputs in the LOW state. In the clear mode all outputs are LOW and unaffected by the address and data inputs.

When operating the 9334 as an addressable latch, changing more than one bit of the address could impose a transient wrong address. Therefore, this should only be done while in the memory mode.

The truth table below summarizes the operations of the 9334.

MODE SELECTION

\bar{E}	\bar{C}	MODE
L	H	Addressable Latch
H	H	Memory
L	L	Active HIGH Eight-Channel Demultiplexer
H	L	Clear

TRUTH TABLE

\bar{C}	\bar{E}	D	A ₀	A ₁	A ₂	PRESENT OUTPUT STATES								MODE	
						Q ₀	Q ₁	Q ₂	Q ₃	Q ₄	Q ₅	Q ₆	Q ₇		
L	H	X	X	X	X	L	L	L	L	L	L	L	L	L	CLEAR DEMULTIPLEX
L	L	L	L	L	L	L	L	L	L	L	L	L	L	L	
L	L	H	L	L	L	H	L	L	L	L	L	L	L	L	
L	L	L	H	L	L	L	L	L	L	L	L	L	L	L	
L	L	H	H	L	L	L	H	L	L	L	L	L	L	L	
L	L	H	H	H	L	L	L	H	L	L	L	L	L	L	
L	L	H	H	H	H	L	L	L	L	L	L	L	L	L	
L	L	H	H	H	H	L	L	L	L	L	L	L	L	L	
H	H	X	X	X	X	Q _{N-1} →								MEMORY	
H	L	L	L	L	L	L	Q _{N-1}	Q _{N-1}	Q _{N-1}	Q _{N-1}	Q _{N-1}	Q _{N-1}	Q _{N-1}	Q _{N-1}	ADDRESSABLE LATCH
H	L	H	L	L	L	H	Q _{N-1}	Q _{N-1}	Q _{N-1}	Q _{N-1}	Q _{N-1}	Q _{N-1}	Q _{N-1}	Q _{N-1}	
H	L	L	H	L	L	Q _{N-1}	L	Q _{N-1}	Q _{N-1}	Q _{N-1}	Q _{N-1}	Q _{N-1}	Q _{N-1}	Q _{N-1}	
H	L	H	H	L	L	Q _{N-1}	H	Q _{N-1}	Q _{N-1}	Q _{N-1}	Q _{N-1}	Q _{N-1}	Q _{N-1}	Q _{N-1}	
H	L	L	H	H	L	Q _{N-1}	Q _{N-1}	Q _{N-1}	Q _{N-1}	Q _{N-1}	Q _{N-1}	Q _{N-1}	Q _{N-1}	Q _{N-1}	
H	L	L	H	H	H	Q _{N-1}	Q _{N-1}	Q _{N-1}	Q _{N-1}	Q _{N-1}	Q _{N-1}	Q _{N-1}	Q _{N-1}	Q _{N-1}	
H	L	H	H	H	L	Q _{N-1}	Q _{N-1}	Q _{N-1}	Q _{N-1}	Q _{N-1}	Q _{N-1}	Q _{N-1}	Q _{N-1}	Q _{N-1}	
H	L	H	H	H	H	Q _{N-1}	Q _{N-1}	Q _{N-1}	Q _{N-1}	Q _{N-1}	Q _{N-1}	Q _{N-1}	Q _{N-1}	Q _{N-1}	

X = Don't Care Condition
 L = LOW Voltage Level
 H = HIGH Voltage Level
 Q_{n-1} = Previous Output State

TYPICAL INPUT AND OUTPUT CIRCUITS

INPUTS EQUIVALENT CIRCUIT

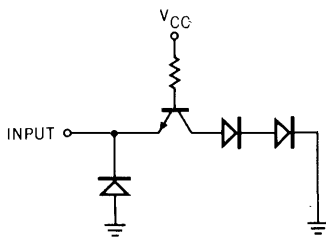

OUTPUTS EQUIVALENT CIRCUIT

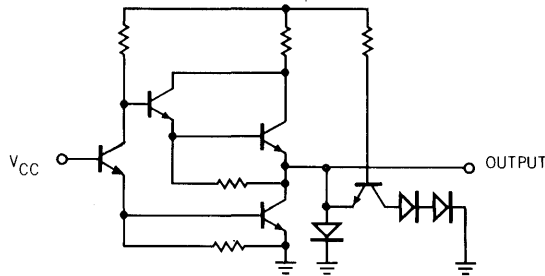

INPUT CURRENT VERSUS INPUT VOLTAGE

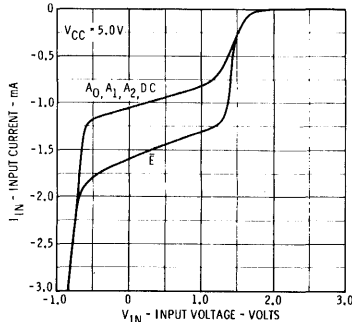

OUTPUT CURRENT VERSUS OUTPUT VOLTAGE (OUTPUT HIGH)

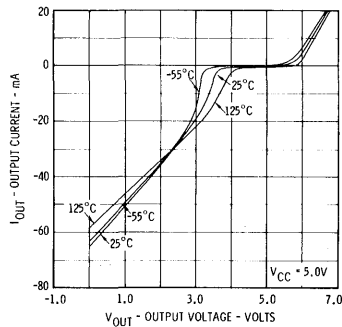

OUTPUT CURRENT VERSUS OUTPUT VOLTAGE (OUTPUT LOW)

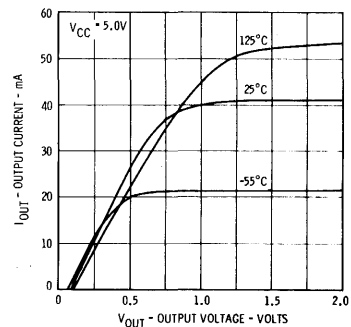

FAIRCHILD TTL/MSI • 9334

ABSOLUTE MAXIMUM RATINGS (above which the useful life may be impaired)

Storage Temperature	-65° C to + 150° C
Temperature (Ambient) Under Bias	-55° C to + 125° C
V _{CC} Pin Potential to Ground Pin	-0.5 V to + 7.0 V
*Input Voltage (dc)	-0.5 V to + 5.5 V
*Input Current (dc)	-30 mA to + 5.0 mA
Voltage Applied to Outputs (Output HIGH)	-0.5 V to + V _{CC} value
Output Current (dc) (Output LOW)	+ 30 mA

*Either Input Voltage limit or Input Current limit is sufficient to protect the inputs.

GUARANTEED OPERATING RANGES

PART NUMBER	SUPPLY VOLTAGE (V _{CC})			TEMPERATURE
	MIN.	TYP.	MAX.	
9334XM	4.5 V	5.0 V	5.5 V	-55° C to 125° C
9334XC	4.75 V	5.0 V	5.25 V	0° C to 75° C

X = package type; F for Flatpak, D for Ceramic Dip, P for Plastic Dip. See Packaging Information Section for packages available on this product.

ELECTRICAL CHARACTERISTICS OVER OPERATING TEMPERATURE RANGE (Unless Otherwise Noted)

SYMBOL	PARAMETER	LIMITS			UNITS	CONDITIONS
		MIN.	TYP. (Note 4)	MAX.		
V _{OH}	Output HIGH Voltage	2.4	3.6		Volts	V _{CC} = MIN., I _{OH} = -720 μA V _{IN} = V _{IH} or V _{IL} per Truth Table
V _{OL}	Output LOW Voltage		0.2	0.4	Volts	V _{CC} = MIN., I _{OL} = 9.6 mA V _{IN} = V _{IH} or V _{IL} per Truth Table
V _{IH}	Input HIGH Level	2.0			Volts	Guaranteed Input Logical HIGH Voltage for all Inputs
V _{IL}	Input LOW Level			0.8	Volts	Guaranteed Input Logical LOW Voltage for all Inputs
V _{CD}	Input Clamp Diode Voltage			-1.5	Volts	V _{CC} = MIN., I _{IN} = -12 mA, T _A = 25° C
I _{IL}	Input LOW Current A ₀ , A ₁ , A ₂ , D, \bar{C} \bar{E}		-0.96 -1.44	-1.6 -2.4	mA	V _{CC} = MAX., V _{IN} = 0.4 V
I _{IH}	Input HIGH Current A ₀ , A ₁ , A ₂ , D, \bar{C} \bar{E}		10 15	40 60	μA	V _{CC} = MAX., V _{IN} = 2.4 V
	Input HIGH Current			1.0	mA	V _{CC} = MAX., V _{IN} = 5.5 V
I _{SC}	Output Short Circuit Current (Note 5)	-30	-65	-100	mA	V _{CC} = MAX., V _{OUT} = 0.0 V
I _{CC}	Power Supply Current		56	86	mA	V _{CC} = MAX.

NOTES:

- (1) The actual testing procedures used to guarantee the Electrical Characteristics are contained in a detailed Customer Sample Specification. A copy of this specification can be obtained from Fairchild Digital Product Marketing, Mountain View, California.
- (2) Conditions for testing, not shown in the Table, are chosen to guarantee operation under "worst case" conditions.
- (3) The specified LIMITS represent the "worst case" value for the parameter. Since these "worst case" values normally occur at the temperature and supply voltage extremes, additional noise immunity and guard banding can be achieved by decreasing the allowable system operating ranges.
- (4) Typical limits are at V_{CC} = 5.0 V, 25° C, and max. loading.
- (5) Not more than one output should be shorted at a time.

SWITCHING CHARACTERISTICS ($T_A = 25^\circ\text{C}$)

SYMBOL	PARAMETER	LIMITS			UNITS	CONDITIONS
		MIN.	TYP.	MAX.		
t_{PLH}	Turn-Off Delay Enable to Output		19	23	ns	$V_{CC} = 5.0\text{ V}$, $C_L = 15\text{ pF}$ Fig. 1
t_{PHL}	Turn-On Delay Enable to Output		16	24	ns	
t_{PLH}	Turn-Off Delay Data to Output		28	35	ns	$V_{CC} = 5.0\text{ V}$, $C_L = 15\text{ pF}$ Fig. 2
t_{PHL}	Turn-On Delay Data to Output		16	24	ns	
t_{PLH}	Turn-Off Delay Address to Output			35	ns	$V_{CC} = 5.0\text{ V}$, $C_L = 15\text{ pF}$ Fig. 3
t_{PHL}	Turn-On Delay Address to Output			35	ns	
t_{PHL}	Turn-On Delay Clear to Output		21	25	ns	$V_{CC} = 5.0\text{ V}$, $C_L = 15\text{ pF}$ Fig. 5

SWITCHING SET-UP REQUIREMENTS ($T_A = 25^\circ\text{C}$)

SYMBOL	PARAMETER	LIMITS			UNITS	CONDITIONS
		MIN.	TYP.	MAX.		
$t_s(H)$	Set-up Time HIGH Data to Enable	20	13		ns	$V_{CC} = 5.0\text{ V}$ Fig. 4
$t_h(H)$	Hold Time HIGH Data to Enable	0	-10		ns	
$t_s(L)$	Set-up Time LOW Data to Enable	17	10		ns	$V_{CC} = 5.0\text{ V}$ Fig. 4
$t_h(L)$	Hold Time LOW Data to Enable	0	-13		ns	
$t_s(A-\bar{E})$	Set-up Time Address to Enable (See Note 6)	5	0		ns	$V_{CC} = 5.0\text{ V}$ Fig. 6
$t_{pw}(\bar{E})$	Enable Pulse Width	17	11		ns	$V_{CC} = 5.0\text{ V}$ Fig. 1

NOTES:

- (6) The Address to Enable Set-up Time is the time before the HIGH to LOW Enable transition that the Address must be stable so that the correct latch is addressed and the other latches are not affected.
- (7) The shaded areas indicate when the inputs are permitted to change for predictable output performance.

Fig. 1 TURN-ON & TURN-OFF DELAYS ENABLE TO OUTPUT AND ENABLE PULSE WIDTH

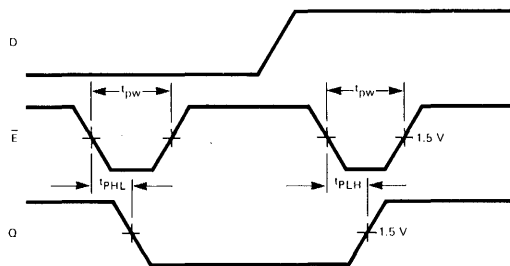

OTHER CONDITIONS: $\bar{C} = H$, $A = \text{STABLE}$

Fig. 2 TURN-ON & TURN-OFF DELAYS DATA TO OUTPUT

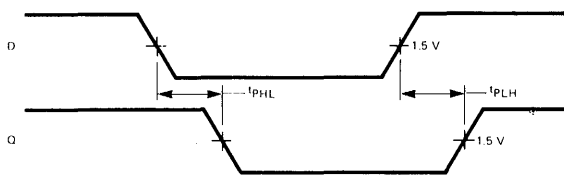

OTHER CONDITIONS: $\bar{E} = L$, $\bar{C} = H$, $A = \text{STABLE}$

Fig. 3 TURN-ON & TURN-OFF DELAYS ADDRESS TO OUTPUT

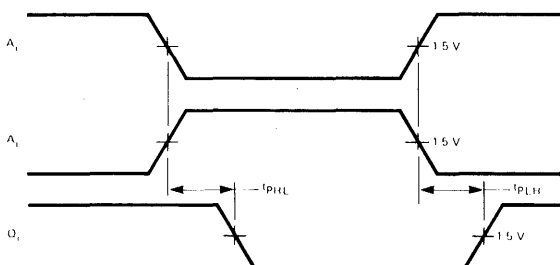

OTHER CONDITIONS: $\bar{E} = L$, $\bar{C} = L$, $D = H$

Fig. 4 SET-UP AND HOLD TIME DATA TO ENABLE

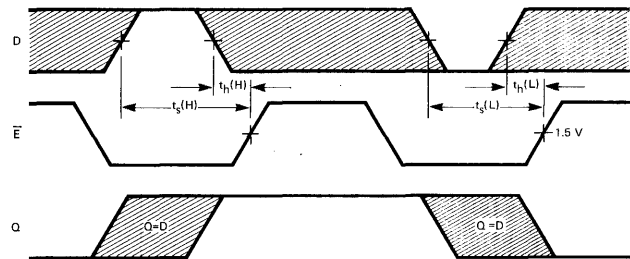

OTHER CONDITIONS: $\bar{C} = H$, $A = \text{STABLE}$

Fig. 5 TURN-ON DELAY CLEAR TO OUTPUT

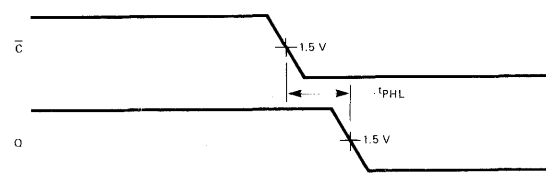

OTHER CONDITIONS: $\bar{E} = H$

Fig. 6 SET-UP TIME ADDRESS TO ENABLE (SEE NOTES 6 & 7)

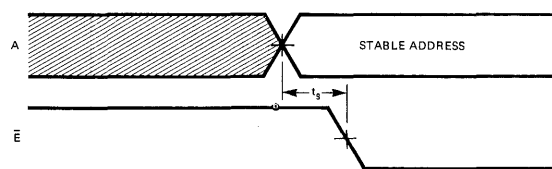

OTHER CONDITIONS: $\bar{C} = H$

TTL/MSI 9338

8-BIT MULTIPLE PORT REGISTER

DESCRIPTION — The TTL/MSI 9338 is an 8-Bit Multiple Port Register designed for high speed random access memory applications where the ability to simultaneously read and write is desirable. A common use would be as a register bank in a three address computer. Data can be written into any one of the eight bits and read from any two of the eight bits simultaneously. The circuit uses TTL technology and is compatible with all members of Fairchild's TTL family.

- MASTER/SLAVE OPERATION PERMITTING SIMULTANEOUS WRITE/READ WITHOUT RACE PROBLEMS
- SIMULTANEOUSLY READ TWO BITS AND WRITE ONE BIT IN ANY ONE OF EIGHT BIT POSITIONS
- READILY EXPANDABLE TO ALLOW FOR LARGER WORD SIZES
- INPUT CLAMP DIODES LIMIT HIGH SPEED TERMINATION EFFECTS
- ALL CERAMIC "HERMETIC" 16 LEAD DUAL IN-LINE AND FLATPAKS
- TTL COMPATIBLE

PIN NAMES

A ₀ , A ₁ , A ₂	Write Address Inputs
D _A	Data Input
B ₀ , B ₁ , B ₂	B Read Address Inputs
Z _B	B Output (Note b)
C ₀ , C ₁ , C ₂	C Read Address Inputs
Z _C	C Output (Note b)
CP	Clock Pulse Input
$\overline{\text{SLE}}$	Slave Enable (Active LOW) Input

LOADING

(Note a)
2/3 U.L.
2/3 U.L.
2/3 U.L.
10 U.L.
2/3 U.L.
10 U.L.
2/3 U.L.
2/3 U.L.

NOTES:

- 1 Unit Load (U.L.) = 40 μ A HIGH/1.6 mA LOW.
- 10 U.L. is the output LOW drive factor and 20 U.L. is the output HIGH drive factor.

LOGIC DIAGRAM

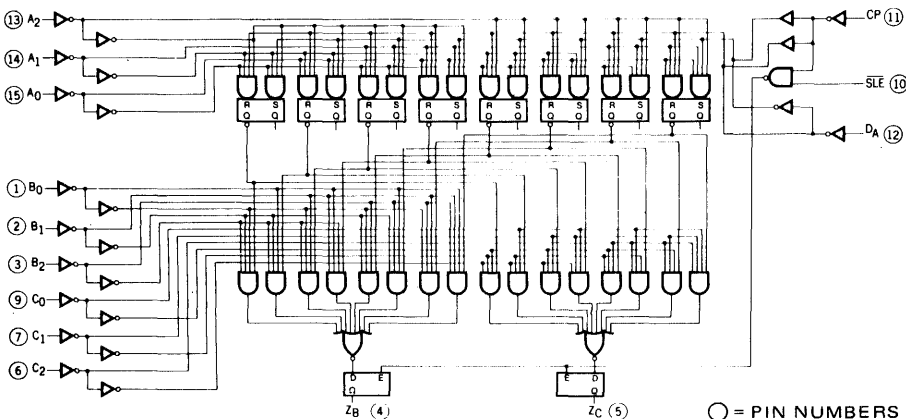

LOGIC SYMBOL

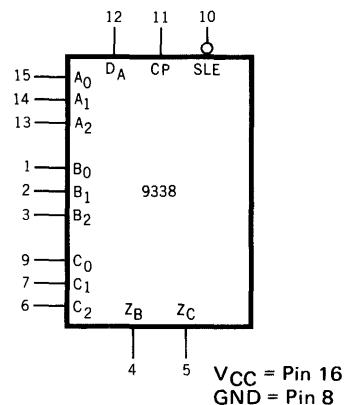

CONNECTION DIAGRAMS DIP (TOP VIEW)

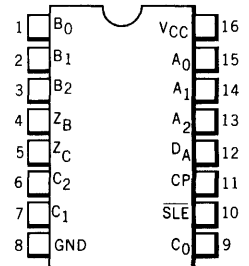

FLATPAK (TOP VIEW)

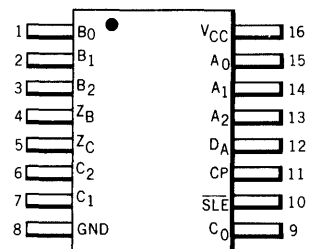

FUNCTIONAL DESCRIPTION — The 9338 8-bit multiple port register may be considered as a 1-bit slice of eight high speed working registers. Data may be written into any one of eight storage locations and read out from any two of the eight storage locations simultaneously. Master/slave operation eliminates all race problems associated with simultaneous writing in and reading from the same location.

The timing of this data transfer is similar to that of a standard master/slave flip-flop. While the clock is LOW the slaves are held steady, but the information on the D (data) input is permitted to enter the selected master. The next clock transition from LOW to HIGH locks the masters in their present states making them insensitive to the D input and write address inputs. This rising clock edge also connects each of the two slaves to the selected masters causing their contents to be reflected on the outputs. Outputs change, therefore, following the LOW to HIGH transition of the clock as on almost all Fairchild TTL/MSI devices and TTL flip-flops.

The Slave Enable (\overline{SLE}) input may be used to defeat the master/slave operation. If the Slave Enable (\overline{SLE}) line is held LOW, the slaves are continuously enabled allowing immediate transfer of information from the selected masters to the outputs.

TYPICAL INPUT AND OUTPUT CIRCUITS

INPUT EQUIVALENT CIRCUIT

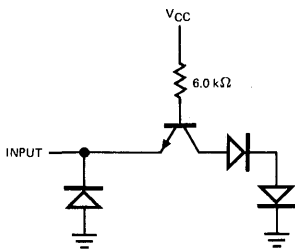

OUTPUT EQUIVALENT CIRCUIT

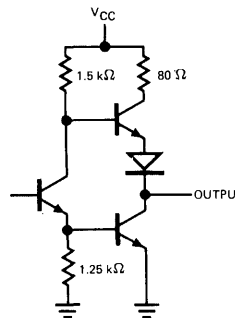

TYPICAL INPUT AND OUTPUT CHARACTERISTICS

INPUT CURRENT VERSUS INPUT VOLTAGE
 DA A2 A1 A0 C2 C1 C0 B2 B1 B0 CP

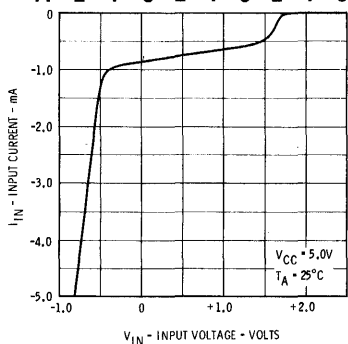

Fig. 1

INPUT CURRENT VERSUS INPUT VOLTAGE
 \overline{SLE}

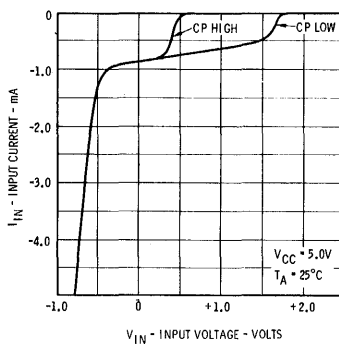

Fig. 2

OUTPUT CURRENT VERSUS OUTPUT VOLTAGE Z_B AND Z_C (LOW STATE)

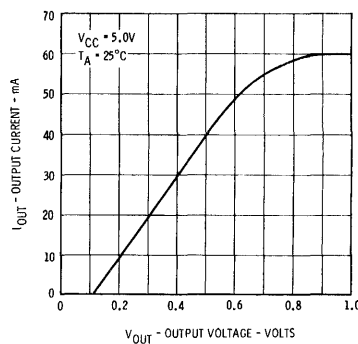

Fig. 3

ABSOLUTE MAXIMUM RATINGS (above which the useful life may be impaired)

- Storage Temperature -65°C to +150°C
- Temperature (Ambient) Under Bias -55°C to +125°C
- V_{CC} Pin Potential to Ground Pin -0.5 V to +7.0 V
- *Input Voltage (dc) -0.5 V to +5.5 V
- *Input Current (dc) -30 mA to +5.0 mA
- Voltage Applied to Outputs (Output HIGH) -0.5 V to +V_{CC}
- Output Current (dc) (Output LOW) +30 mA

*Either Input Voltage limit or Input Current limit is sufficient to protect the inputs.

FAIRCHILD TTL/MSI • 9338

GUARANTEED OPERATING RANGES

PART NUMBER	SUPPLY VOLTAGE (V _{CC})			TEMPERATURE
	MIN.	TYP.	MAX.	
9338XM	4.50 V	5.0 V	5.50 V	-55°C to +125°C
9338XC	4.75 V	5.0 V	5.25 V	0°C to 75°C

X=package type; F for Flatpak, D for Ceramic Dip, P for Plastic Dip. See Packaging Information Section for packages available on this product.

ELECTRICAL CHARACTERISTICS OVER OPERATING TEMPERATURE RANGE (Unless Otherwise Noted)

SYMBOL	PARAMETER	LIMITS			UNITS	CONDITIONS
		MIN.	TYP. (Note 4)	MAX.		
V _{IH}	Input HIGH Voltage	2.0			Volts	Guaranteed Input HIGH Voltage for all Inputs
V _{IL}	Input LOW Voltage			0.8	Volts	Guaranteed Input LOW Voltage for all Inputs
V _{CD}	Input Clamp Diode Voltage			-1.5	Volts	V _{CC} = MIN., I _{IN} = -12mA, T _A = 25°C
V _{OH}	Output HIGH Voltage	2.4	3.6		Volts	V _{CC} = MIN., I _{OH} = -0.8mA V _{IN} = V _{IH}
V _{OL}	Output LOW Voltage		0.2	0.4	Volts	V _{CC} = MIN., I _{OL} = 16mA V _{IN} = V _{IL}
I _{IH}	Input HIGH Current			27	μA	V _{CC} = MAX., V _{IN} = 2.4 V
				1.0	mA	V _{CC} = MAX., V _{IN} = 5.5 V
I _{IL}	Input LOW Current		-0.64	-1.1	mA	V _{CC} = MAX., V _{IN} = 0.4 V
I _{SC}	Output Short Circuit Current (Note 5)	-10	-50	-70	mA	V _{CC} = MAX., V _{OUT} = 0 V
I _{CC}	Power Supply Current		85	135	mA	V _{CC} = MAX.

NOTES:

- (1) The actual testing procedures used to guarantee the Electrical Characteristics are contained in a detailed Customer Sample Specification. A copy of this specification can be obtained from Fairchild Digital Product Marketing, Mountain View, California.
- (2) Conditions for testing, not shown in the Table, are chosen to guarantee operation under "worst case" conditions.
- (3) The specified LIMITS represent the "worst case" value for the parameter. Since these "worst case" values normally occur at the temperature and supply voltage extremes, additional noise immunity and guard banding can be achieved by decreasing the allowable system operating ranges.
- (4) Typical limits are at V_{CC} = 5.0 V, 25°C, and maximum loading.
- (5) Not more than one output should be shorted at a time.

SWITCHING CHARACTERISTICS (T_A = 25°C)

SYMBOL	PARAMETER	LIMITS			UNITS	CONDITIONS
		MIN.	TYP.	MAX.		
t _{PLH}	Turn-Off Delay Address to Output	13	25	40	ns	V _{CC} = 5.0 V C _L = 15 pF
t _{PHL}	Turn-On Delay Address to Output	18	27	35	ns	
t _{PLH}	Turn-Off Delay Data to Output	25	33	45	ns	
t _{PHL}	Turn-On Delay Data to Output	25	37	50	ns	
t _{PLH}	Turn-Off Delay Clock to Output	18	26	35	ns	
t _{PHL}	Turn-On Delay Clock to Output	13	21	30	ns	

SWITCHING SET-UP REQUIREMENTS (T_A = 25°C)

SYMBOL	PARAMETER	LIMITS			UNITS	CONDITIONS	
		MIN.	TYP.	MAX.			
t _s "H"	Set-up Time HIGH Data to Clock	20	14		ns	V _{CC} = 5.0 V	
t _h "H"	Hold Time HIGH Data to Clock	0	-7		ns		
t _s "L"	Set-up Time LOW Data to Clock	12	7		ns		
t _h "L"	Hold Time LOW Data to Clock	-8	-14		ns		
t _s (A)	Set-up Time (A) Address to Clock	10	5		ns		
t _h (A)	Hold Time (A) Address to Clock	0			ns		
t _{CP} "L"	Clock LOW Time Required to Write	13	7.0		ns		
t _{CP} "H"	Clock HIGH Time Required to Read	23	15		ns		
							See Fig. 4
							See Fig. 7
						See Fig. 8	

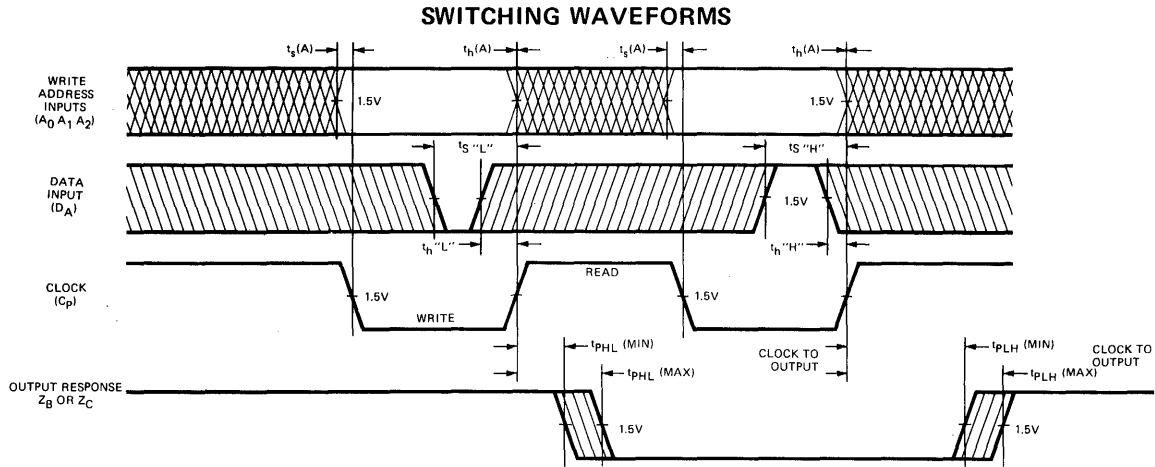

The crosshatched areas of the input waveforms indicate when inputs are permitted to change. The crosshatched areas on the output response waveforms indicate minimum and maximum propagation delays.

Fig. 4 DATA AND WRITE ADDRESS SETUP TIMES; READ TIME (CLOCK PULSE TO OUTPUT)

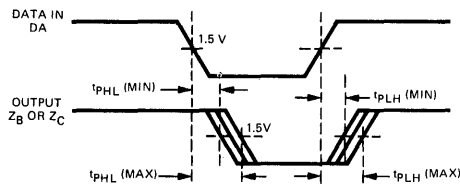

OTHER CONDITIONS

1. CP = LOW
2. SLE = LOW
3. A₂, A₁, A₀ = B₂, B₁, B₀ = C₂, C₁, C₀

Fig. 5 tpLH/tpHL (DATA INPUT TO OUTPUT)

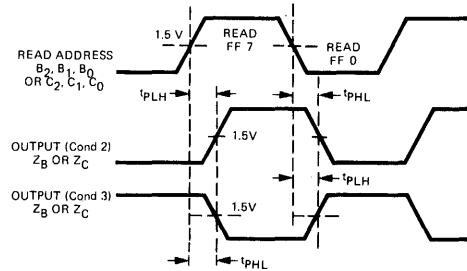

OTHER CONDITIONS

1. CP = HIGH
2. Master FF 7 = H
3. Master FF 0 = L
- Master FF 0 = H

Fig. 6 tpLH/tpHL (READ ADDRESS TO OUTPUT)

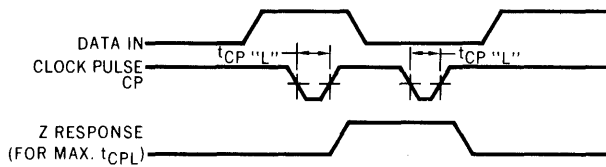

OTHER CONDITIONS

1. SLE = LOW
2. A₂, A₁, A₀ = B₂, B₁, B₀ = C₂, C₁, C₀

Fig. 7 t_{CP}"L" (CLOCK LOW TIME REQUIRED TO WRITE)

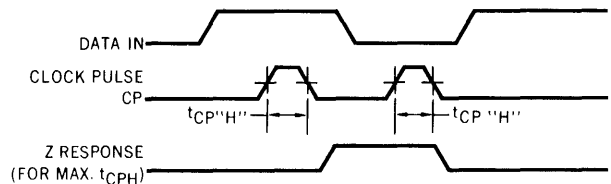

OTHER CONDITIONS

1. SLE = HIGH
2. A₂, A₁, A₀ = B₂, B₁, B₀ = C₀, C₁, C₂

Fig. 8 t_{CP}"H" (CLOCK HIGH TIME REQUIRED TO READ)

DEFINITION OF TERMS

DATA SET UP TIME (t_s) — Is defined as the time required for a HIGH (t_s "H") or a LOW (t_s "L") logic level to be present at the data input prior to the clock transition from LOW to HIGH, in order for the master to recognize and store the new data.

t_{CP} "L" (CLOCK LOW TIME REQUIRED TO WRITE) — This parameter is defined as the minimum LOW clock pulse width required to write information into the master.

t_{CP} "H" (CLOCK HIGH TIME REQUIRED TO READ) — This parameter is defined as the minimum HIGH clock pulse width required to store information in the slaves.

WRITE ADDRESS SET-UP TIME t_s(A) — Is the time required for the write address to be present before the HIGH to LOW clock transition so that the correct master is addressed and other masters are not disturbed. When writing data into the 9338, the write address inputs should be stable at t_s(A) before the HIGH to LOW transition of the clock and while the clock is LOW but they may change simultaneously with the LOW to HIGH clock transition.

HOLD TIME (t_h) is defined as the minimum time following the clock transition from LOW to HIGH that the logic level must be maintained at the input in order to insure continued recognition. A negative HOLD TIME indicates that the correct logic level may be released prior to the clock transition from LOW to HIGH and still be recognized.

TYPICAL SWITCHING CHARACTERISTICS

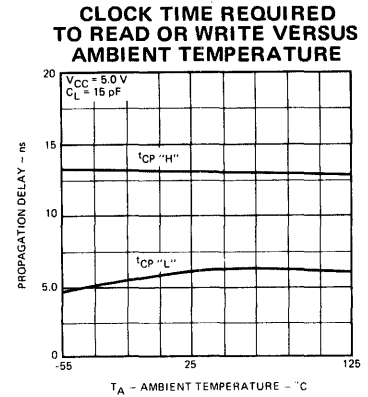
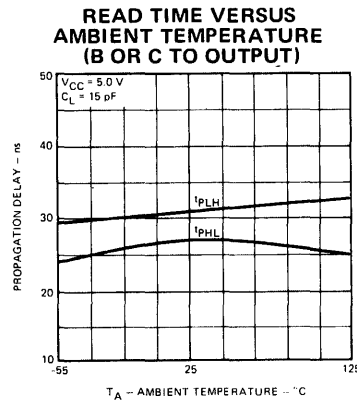
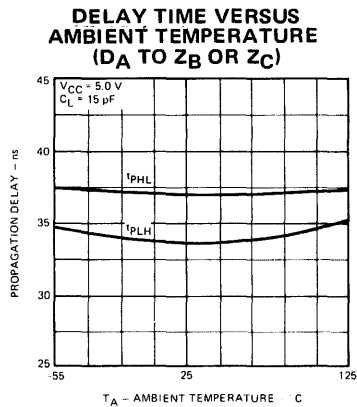
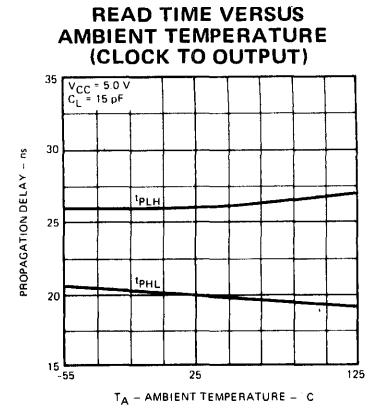
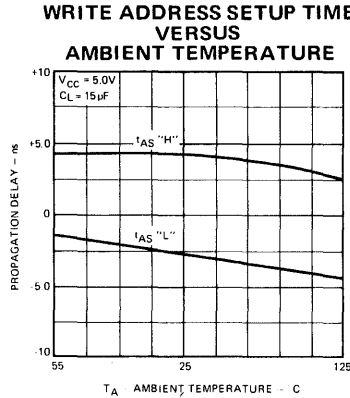
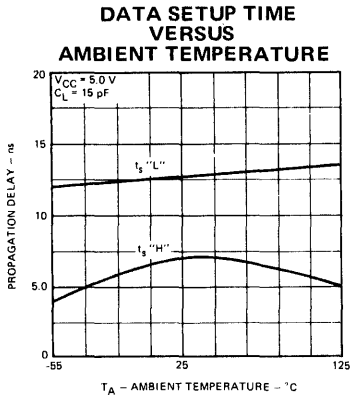

APPLICATIONS

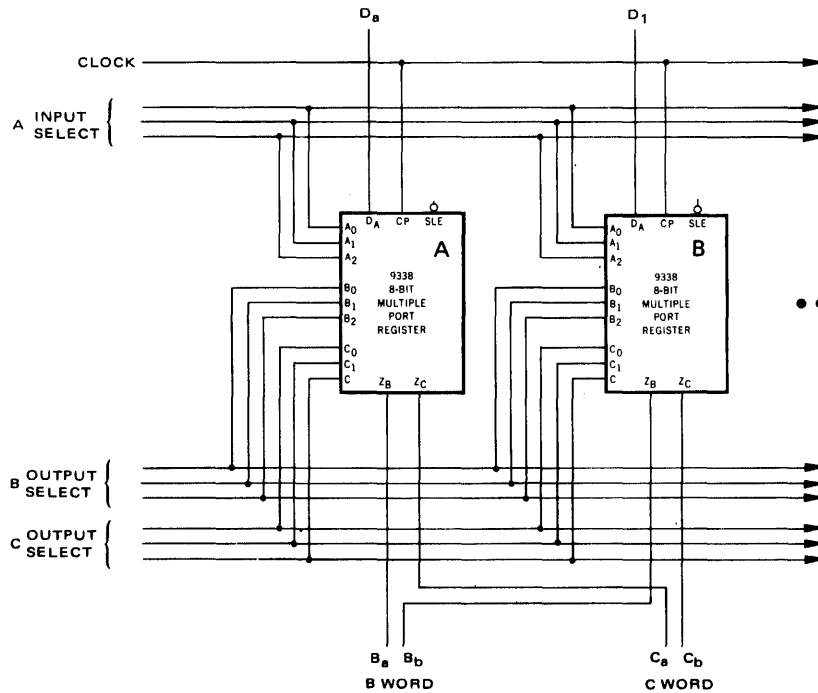

Fig. 9 PARALLEL EXPANSION

One 9338 is needed for each bit of the required word length. The read and write input lines should be connected in common on all of the devices. This register configuration provides two words of n-bits each at one time as is illustrated above, where n devices are connected in parallel.

TTL/MSI 93S39

8-BIT EDGE TRIGGERED MULTIPLE PORT REGISTER

TO BE ANNOUNCED

DESCRIPTION — The TTL/MSI 93S39 is an 8-bit, edge triggered, multiple port register designed with the super high speed Schottky-barrier diode clamp circuit. It is organized as a 1-bit slice of eight storage registers for use as accumulators, data registers, or scratch pad memory. It is primarily intended to be used with an arithmetic logic unit (ALU) such as the 93S41/74S181 to provide very high speed arithmetic operations.

The 93S39 is essentially an 8-bit register having one input data line and three output ports. Data can be written into any one of eight locations, selected by address lines A_0 thru A_2 . Because of the master/slave design, the previous data can be read out of that same location simultaneously on output Z_A . In addition data can be read out from any other location on output Z_B , under control of the second output multiplexer, addressed by B_0 thru B_2 . Individual multiplexer enable controls to the Z_A and Z_B outputs allow for easy expansion to more than eight registers. A separate Z_0 output is provided which continuously displays the contents of location 0, which can be used as a P register.

The 93S39 features edge triggered inputs on the write enable, data, and write address lines, which respond only to the LOW to HIGH transition of the clock. This insures the longest possible time for propagation of signals through external combinatorial logic, as the stability of the input address, the new data, and the write enable must be controlled only within the set-up time requirements of the rising edge of the clock. The outputs Z_A and Z_B are asynchronous, depending only on the delay of the multiplexer address and enable controls. The output enables are designed to permit OR-tying the outputs for easy expansion to more than eight registers.

- THE WRITE CONTROLS (WRITE ENABLE, WRITE ADDRESS, AND DATA) ARE EDGE TRIGGERED—RESPONDING ONLY TO THE POSITIVE TRANSITION OF THE CLOCK PULSE
- SCHOTTKY-BARRIER DIODE DESIGN FOR SUPER HIGH SPEED OPERATION
- ASYNCHRONOUS CONTROL OF OUTPUT DATA MULTIPLEXERS
- OUTPUT MULTIPLEXER DESIGN PROVIDES FOR EASY REGISTER EXPANSION
- CONTINUOUS OUTPUT FROM BIT LOCATION "000" FOR MEMORY ADDRESS REGISTER APPLICATIONS

PIN NAMES

A_0, A_1, A_2	Write Address and "A" Multiplexer Address Inputs	WE	Write Enable Input
\bar{E}_A	"A" Multiplexer Enable (Active LOW) Input	CP	Clock Pulse (Active HIGH going edge) Input
B_0, B_1, B_2	"B" Multiplexer Address Inputs	Z_0	Output from Bit Location "000"
\bar{E}_B	"B" Multiplexer Enable (Active LOW) Input	Z_A	Output from "A" Multiplexer
D	Data Input	Z_B	Output from "B" Multiplexer

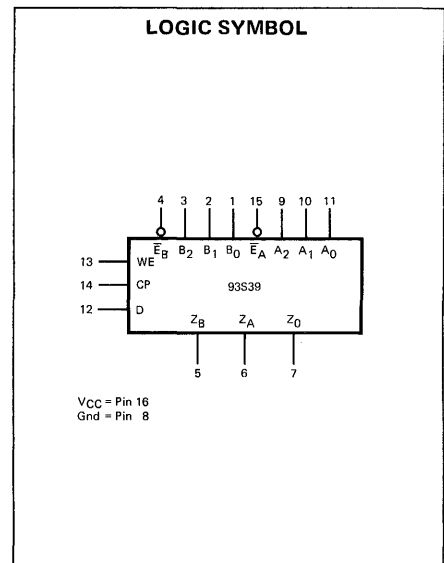
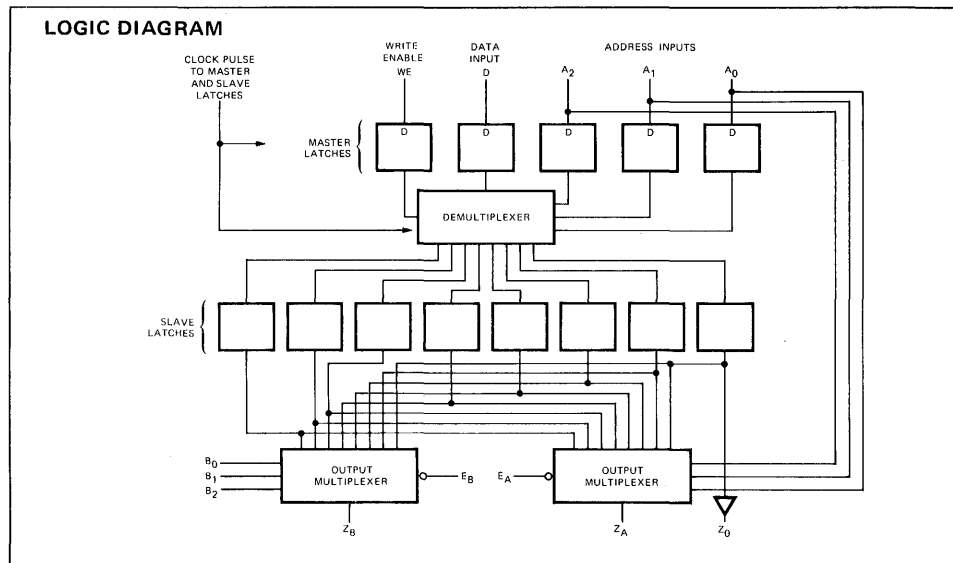

TTL/MSI 9340

4-BIT ARITHMETIC LOGIC UNIT WITH CARRY LOOKAHEAD

DESCRIPTION – The 9340 is a TTL/MSI high speed Arithmetic Logic Unit with full on chip carry lookahead circuitry. It can perform the arithmetic operations add or subtract in parallel, or either of six logic functions on two 4-bit binary words. The internal carry lookahead provides either a ripple carry output or carry lookahead outputs. An internal carry input network accepts carry lookahead outputs from up to three other packages producing a 16-bit full carry lookahead ALU without additional gates. Ripple carries can be used between additional blocks of 12 bits to further expand the word length. A low power version of the 9340 is available as the 93L40, dissipating only 110 mW.

MULTIFUNCTION CAPABILITY

Two Arithmetic Operations – Add, Subtract
Six Logic Functions – A Ex or B, A and B, Plus Four Others

- ADD TWO 4-BIT WORDS IN 23 ns TYPICAL
- SUBTRACT TWO 4-BIT WORDS IN 28 ns
- LOOKAHEAD CARRY INPUT AND OUTPUT NETWORKS ON CHIP
- EASILY EXPANDABLE TO LONGER WORD LENGTHS
- TYPICAL POWER DISSIPATION OF 425 mW
- INPUT CLAMP DIODES LIMIT HIGH SPEED TERMINATION EFFECTS
- TTL COMPATIBLE

PIN NAMES

\overline{A}_0 to \overline{A}_3 , \overline{B}_0 to \overline{B}_3	Operand Active LOW Inputs	3 U.L.
S_0 , S_1	Mode Select Inputs	1 U.L.
\overline{CG}_1	Active LOW Carry Generate Input from immediately preceding stage	3 U.L.
\overline{CP}_1	Active LOW Carry Propagate Input from immediately preceding stage	1 U.L.
\overline{CG}_2	Active LOW Carry Generate Input from second preceding stage	2 U.L.
\overline{CP}_2	Active LOW Carry Propagate Input from second preceding stage	1 U.L.
\overline{CG}_3	Active LOW Carry Generate Input from third preceding stage	1 U.L.
COE	Carry Out Enable Input	1.5 U.L.
\overline{F}_0 , \overline{F}_1 , \overline{F}_2 , \overline{F}_3	Function (Active LOW) Outputs (Note b)	10 U.L.
$\overline{CO/CG}$	Carry Out/Carry Generate (Active LOW) Output (Note b)	10 U.L.
\overline{CP}	Carry Propagate (Active LOW) Output (Note b)	10 U.L.

Notes: a. 1 Unit Load (U.L.) = 40μA HIGH/1.6mA LOW
b. 10 U.L. is the output LOW drive factor and 20 U.L. is the output HIGH drive factor.

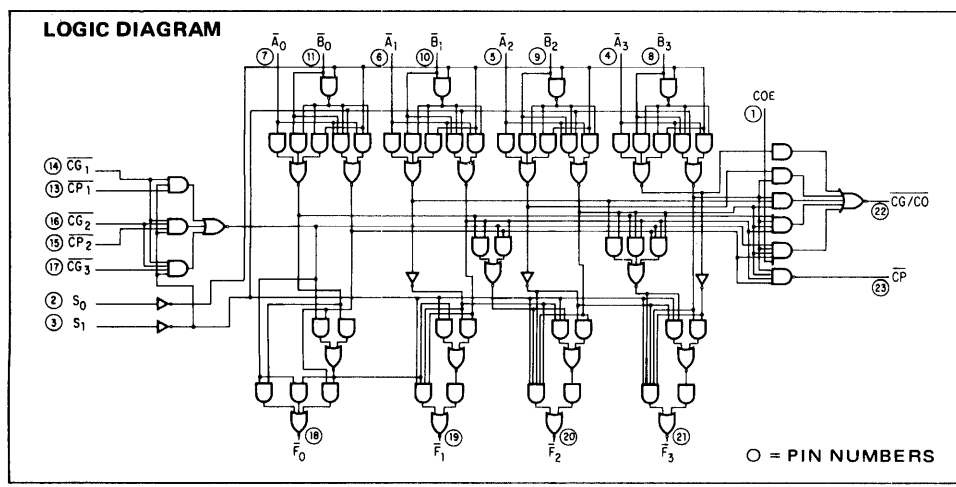
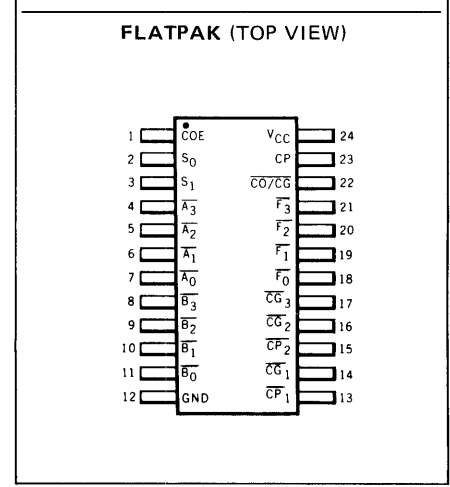
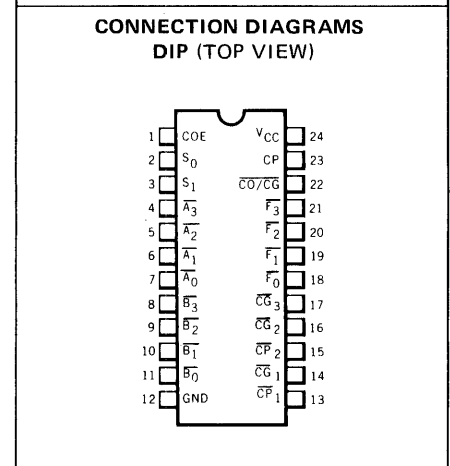
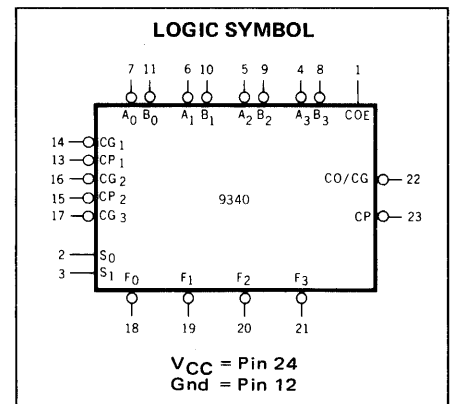

FAIRCHILD TTL/MSI • 9340

FUNCTIONAL DESCRIPTION – The 9340 accepts two 4-bit words, A_0, A_1, A_2, A_3 (A_{0-3}) and B_0, B_1, B_2, B_3 (B_{0-3}), and produces a 4-bit output, F_0, F_1, F_2, F_3 (F_{0-3}). The output function is determined by the states on the control lines S_0 and S_1 . The inputs and outputs of the 9340 may be considered to be active level LOW or active level HIGH. Logic equivalents for four representations of the 9340 are shown in Figure 1a, b, c, and d.

The add and subtract operations are performed on the entire word, with carries or borrows propagated between bits of different weight. The arithmetic may be performed in 1's complement, 2's complement, or sign-magnitude notation. In the logic modes, carries are inhibited and the device acts like four gates of the type shown in Figure 1.

To achieve high speed operation, the 9340 is designed to be used in a carry lookahead system. Full carry lookahead is used inside the device to propagate carries between bits. Carry lookahead functions over the 4-bit block are available as outputs. These outputs are labeled $\overline{CO}/\overline{CG}$ (Carry Out/Carry Generate) and \overline{CP} (Carry Propagate) on the logic symbol. The carry in to the device is formed from a set of Carry Generate and Carry Propagate inputs (equation 1) so that three 9340's can be interconnected without any additional gates to form a 12-bit full carry lookahead ALU with a carry in. The pin labeled COE (Carry Out Enable) controls the $\overline{CO}/\overline{CG}$ output according to equation 2. When COE is HIGH, $\overline{CO}/\overline{CG}$ becomes a Carry Out which can be used to ripple carries between blocks of 12 bits. The \overline{CG}_1 input can be used for a ripple carry input, since this signal is sufficient to produce a carry in.

EQUATION:

- (1) $(\overline{CG}_1) + (\overline{CP}_1) (\overline{CG}_2) + (\overline{CP}_1) (\overline{CP}_2) (\overline{CG}_3) = C_{in}$ (internal)
- (2) $\overline{CO}/\overline{CG} = (\overline{CG}) + (\overline{CP}) (C_{in}) (COE)$

Fig. 1—FUNCTION TABLES FOR LOGIC EQUIVALENTS OF THE 9340

Note that when the input operands are defined as active HIGH, the carry lookahead inputs and outputs are not formally carry generate and carry propagate. Consequently, these pins have been relabeled CX and CY in the active HIGH cases. However, the signals are connected in the same manner as \overline{CG} and \overline{CP} .

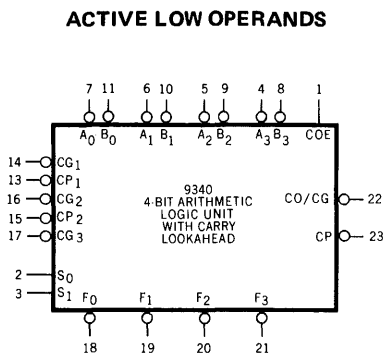

V_{CC} = Pin 24
Gnd = Pin 12

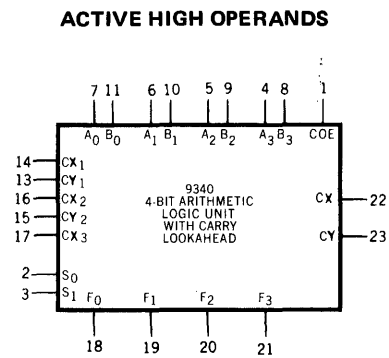

V_{CC} = Pin 24
Gnd = Pin 12

CONTROL INPUTS	OPERATION	EQUIVALENT LOGIC
S_0 S_1		
L L	A SUBTRACT B	
H L	A ADD B	
L H	A EX OR B	
H H	A AND B	

Fig. 1a

CONTROL INPUTS	OPERATION	EQUIVALENT LOGIC
S_0 S_1		
L L	A SUBTRACT B	
H L	A ADD B	
L H	A EQUIV B	
H H	A OR B	

Fig. 1b

ACTIVE LOW OPERANDS WITH INVERTED B

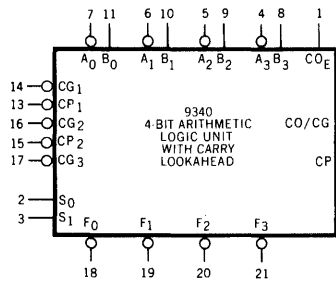

V_{CC} = Pin 24
Gnd = Pin 12

ACTIVE HIGH OPERANDS WITH INVERTED B

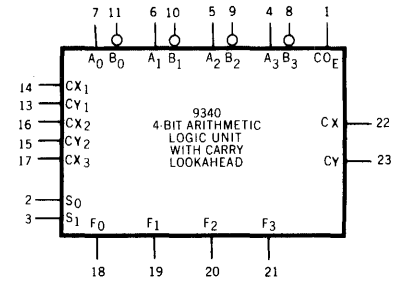

V_{CC} = Pin 24
Gnd = Pin 12

CONTROL INPUTS	OPERATION	EQUIVALENT LOGIC
S_0 S_1		
L L	A ADD B	
H L	A SUBTRACT B	
L H	A EQUIV B	
H H	A AND \bar{B}	

Fig.1c

CONTROL INPUTS	OPERATION	EQUIVALENT LOGIC
S_0 S_1		
L L	A ADD B	
H L	A SUBTRACT B	
L H	A EX OR B	
H H	A OR \bar{B}	

Fig.1d

TYPICAL INPUT AND OUTPUT CIRCUITS

INPUTS EQUIVALENT CIRCUIT

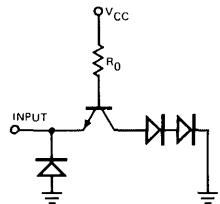

OUTPUTS EQUIVALENT CIRCUITS

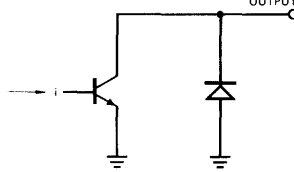

LOW

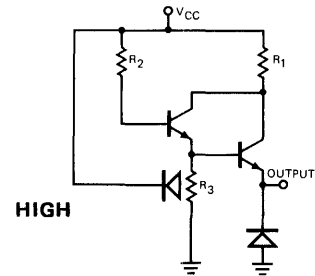

HIGH

INPUT CURRENT VERSUS INPUT VOLTAGE

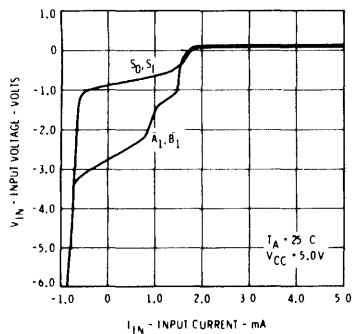

OUTPUT CURRENT VERSUS OUTPUT VOLTAGE LOW STATE

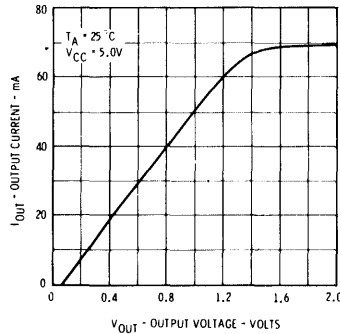

OUTPUT CURRENT VERSUS OUTPUT VOLTAGE HIGH STATE

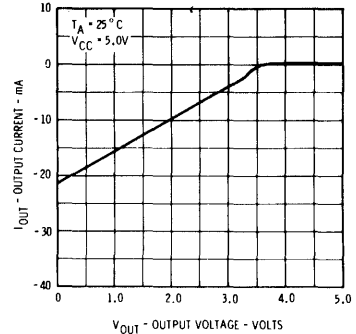

FAIRCHILD TTL/MSI • 9340

ABSOLUTE MAXIMUM RATINGS (above which the useful life may be impaired)

Storage Temperature	-65°C to +150°C
Temperature (Ambient) Under Bias	-55°C to +125°C
V _{CC} Pin Potential to Ground Pin	-0.5 V to +7.0 V
*Input Voltage (dc)	-0.5 V to +5.5 V
*Input Current (dc)	-30 mA to +5.0 mA
Voltage Applied to Outputs (Output HIGH)	-0.5 V to +V _{CC} value
Output Current (dc) (Output LOW)	+30 mA

*Either Input Voltage Limit or Input Current is sufficient to protect the inputs.

GUARANTEED OPERATING RANGES

PART NUMBER	SUPPLY VOLTAGE (V _{CC})			TEMPERATURE
	MIN.	TYP.	MAX.	
9340XM	4.5 V	5.0 V	5.5 V	-55°C to 125°C
9340XC	4.75 V	5.0 V	5.25 V	0°C to 75°C

X = package type; F for Flatpak, D for Ceramic Dip, P for Plastic Dip. See Packaging Information Section for packages available on this product.

ELECTRICAL CHARACTERISTICS OVER OPERATING TEMPERATURE RANGE (unless otherwise noted)

SYMBOL	PARAMETER	LIMITS			UNITS	CONDITIONS
		MIN.	TYP. (Note 4)	MAX.		
V _{IH}	Input HIGH Voltage	2.0			Volts	Guaranteed Input HIGH Threshold Voltage for All Inputs
V _{IL}	Input LOW Voltage			0.8	Volts	Guaranteed Input LOW Threshold Voltage for All Inputs
V _{CD}	Input Clamp Diode Voltage			-1.5	Volts	V _{CC} = MIN., I _{IN} = -12 mA, T _A = 25°C
V _{OH}	Output HIGH Voltage	2.4	3.6		Volts	V _{CC} = MIN., I _{OH} = -800 μA V _{IN} = V _{IH} or V _{IL} per Truth Table
V _{OL}	Output LOW Voltage		0.2	0.4	Volts	V _{CC} = MIN., I _{OL} = 16 mA V _{IN} = V _{IH} or V _{IL} per Truth Table
I _{IH}	Input HIGH Current S ₀ , S ₁ , \overline{CP}_1 , \overline{CP}_2 , \overline{CG}_3 COE \overline{CG}_2 \overline{A}_0 to \overline{A}_3 , \overline{B}_0 to \overline{B}_3 , \overline{CG}_1		10 15 20 30	40 60 80 120	μA	V _{CC} = MAX., V _{IN} = 2.4 V
	Input HIGH Current All Inputs			1.0	mA	V _{CC} = MAX., V _{IN} = 5.5 V
I _{IL}	Input LOW Current S ₀ , S ₁ , \overline{CP}_1 , \overline{CP}_2 , \overline{CG}_3 COE \overline{CG}_2 \overline{A}_0 to \overline{A}_3 , \overline{B}_0 to \overline{B}_3 , \overline{CG}_1		-0.96 -1.44 -1.92 -2.88	-1.6 -2.4 -3.2 -4.8	mA	V _{CC} = MAX., V _{IN} = 0.4 V
	Output Short Circuit Current (Note 5)	-30	-65	-100	mA	V _{CC} = MAX. V _{OUT} = 0.0 V
I _{CC}	Power Supply Current		85	135	mA	V _{CC} = MAX.
			85	146	mA	

NOTES:

- (1) The actual testing procedures used to guarantee the Electrical Characteristics are contained in a detailed Customer Sample Specification. A copy of this specification can be obtained from Fairchild Digital Product Marketing, Mountain View, California.
- (2) Conditions for testing, not shown in the Table, are chosen to guarantee operation under "worst case" conditions.
- (3) The specified LIMITS represent the "worst case" value for the parameter. Since these "worst case" values normally occur at the temperature and supply voltage extremes, additional noise immunity and guard banding can be achieved by decreasing the allowable system operating ranges.
- (4) Typical limits are at V_{CC} = 5.0 V, 25°C, and maximum loading.
- (5) Not more than one output should be shorted at a time.

FAIRCHILD TTL/MSI • 9340

SWITCHING CHARACTERISTICS (T_A = 25°C)

SYMBOL	PARAMETER	LIMITS (Add Mode)			LIMITS (Subtract Mode)			UNITS	TEST CONDITIONS	
		MIN.	TYP.	MAX.	MIN.	TYP.	MAX.			
t _{PLH}	Turn off delay } Data Input to Data		23	30		28	37	ns	See Table 1 and Fig. 3	V _{CC} = 5.0V C _L = 15pF
t _{PHL}		Turn on delay } Output (\overline{B}_0 to \overline{F}_3)		23	30		25			
t _{PLH}	Turn off delay } Data Input to Carry		15	20		18	25	ns	See Table 1 and Fig. 3	
t _{PHL}		Turn on delay } Output (\overline{B}_0 to $\overline{CO/CG}$)		16	20		17			
t _{PLH}	Turn off delay } Carry Input to Carry		15	19		15	19	ns	See Table 1 and Fig. 4	
t _{PHL}		Turn on delay } Output (\overline{CG}_3 to $\overline{CO/CG}$)		15	19		15			
t _{PLH}	Turn off delay } Carry Input to Data		23	31		23	31	ns	See Table 1 and Fig. 4	
t _{PHL}		Turn on delay } Output (\overline{CG}_3 to \overline{F}_3)		22	29		22			29

TABLE I SWITCHING TEST CONDITIONS

PARAMETER	OPERATION	INPUTS AT 4.5V	INPUTS AT GND	WAVEFORM
t _{PLH} (\overline{B}_0 \overline{F}_3) t _{PHL} (\overline{B}_0 \overline{F}_3)	Add	S ₀ , \overline{CG}_1 , \overline{CP}_1 , \overline{B}_1 , \overline{B}_2	S ₁ , \overline{A}_0 , \overline{A}_1 , \overline{A}_2 , \overline{A}_3 , \overline{B}_3	1
t _{PLH} (\overline{B}_0 \overline{F}_3) t _{PHL} (\overline{B}_0 \overline{F}_3)	Subtract	\overline{CG}_1 , \overline{CP}_1 , \overline{B}_3	S ₀ , S ₁ , \overline{A}_0 , \overline{A}_1 , \overline{A}_2 , A ₃ \overline{B}_1 , \overline{B}_2	2
t _{PLH} (\overline{B}_0 $\overline{CO/CG}$) t _{PHL} (\overline{B}_0 $\overline{CO/CG}$)	Add	S ₀ , \overline{CG}_1 , \overline{CP}_1 , \overline{B}_1 , \overline{B}_2 , \overline{B}_3	S ₁ , COE, \overline{A}_0 , \overline{A}_1 , \overline{A}_2 , \overline{A}_3	1
t _{PLH} (\overline{B}_0 $\overline{CO/CG}$) t _{PHL} (\overline{B}_0 $\overline{CO/CG}$)	Subtract	\overline{CG}_1 , \overline{CP}_1	S ₀ , S ₁ , COE, \overline{A}_0 , \overline{A}_1 , \overline{A}_2 , \overline{A}_3 \overline{B}_1 , \overline{B}_2 , \overline{B}_3	2
t _{PLH} (\overline{CG}_3 $\overline{CO/CG}$) t _{PHL} (\overline{CG}_3 $\overline{CO/CG}$)	Add	S ₀ , \overline{CG}_1 , \overline{CG}_2 , COE, \overline{A}_0 , \overline{A}_1 , \overline{A}_2 , \overline{A}_3	S ₁ , \overline{B}_0 , \overline{B}_1 , \overline{B}_2 , \overline{B}_3 \overline{CP}_1 , \overline{CP}_2	1
t _{PLH} (\overline{CG}_3 \overline{F}_3) t _{PHL} (\overline{CG}_3 \overline{F}_3)	Add	S ₀ , \overline{CG}_1 , \overline{CG}_2 , \overline{B}_3 \overline{A}_0 , \overline{A}_1 , \overline{A}_2 , \overline{A}_3	S ₁ , \overline{B}_0 , \overline{B}_1 , \overline{B}_2 \overline{CP}_1 , \overline{CP}_2	1

SWITCHING WAVEFORMS

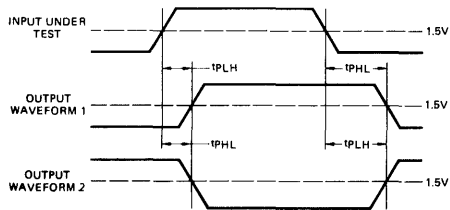

Fig. 2

TYPICAL PROPAGATION DELAYS
DATA INPUT TO DATA OUTPUT
AND
DATA INPUT TO CARRY OUTPUT
(ADD MODE)

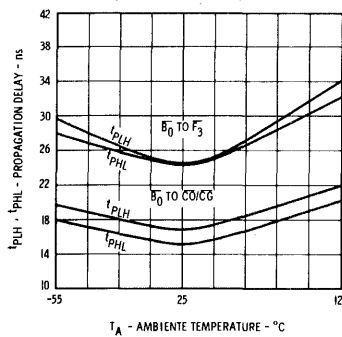

Fig. 3

TYPICAL PROPAGATION DELAYS
CARRY INPUT TO CARRY OUTPUT
AND
CARRY INPUT TO DATA OUTPUT
(ADD MODE)

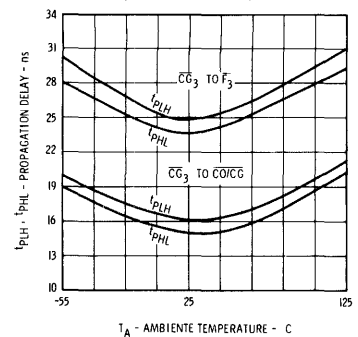

Fig. 4

TTL/MSI 9341/54181, 74181

4-BIT ARITHMETIC LOGIC UNIT

DESCRIPTION — The TTL/MSI 9341/54181, 74181 is a 4-bit high speed Arithmetic Logic Unit (ALU) which can perform all the possible 16 logic operations on two variables and a variety of arithmetic operations; the Add and Subtract modes are the most important. The ALU is fully compatible with all members of the Fairchild TTL family.

- PROVIDES 16 ARITHMETIC OPERATIONS
ADD, SUBTRACT, COMPARE, DOUBLE,
PLUS TWELVE OTHER ARITHMETIC OPERATIONS
- PROVIDES ALL 16 LOGIC OPERATIONS OF TWO VARIABLES
EXCLUSIVE-OR, COMPARE, AND, NAND, OR, NOR, PLUS
TEN OTHER LOGIC OPERATIONS
- FULL LOOKAHEAD FOR HIGH SPEED ARITHMETIC OPERATION ON LONG WORDS
- INPUT CLAMP DIODES
- TTL COMPATIBLE

PIN NAMES

\bar{A}_0 to \bar{A}_3 , \bar{B}_0 to \bar{B}_3	Operand (Active LOW) Inputs
S_0, S_1, S_2, S_3	Function - Select Inputs
M	Mode Control Input
C_n	Carry Input
$\bar{F}_0, \bar{F}_1, \bar{F}_2, \bar{F}_3$	Function (Active LOW) Outputs (Note b)
A = B	Comparator Output
\bar{G}	Carry Generate (Active LOW) Output (Note b)
P	Carry Propagate (Active LOW) Output (Note b)
C_{n+4}	Carry Output (Note b)

NOTES:

- 1 Unit Load (U.L.) = 40 μ A HIGH/1.6 mA LOW.
- 10 U.L. is the output LOW drive factor and 20 U.L. is the output HIGH drive factor.

LOADING (Note a)

	3 U.L.
	4 U.L.
	1 U.L.
	5 U.L.
	10 U.L.
Open Collector	10 U.L.
	10 U.L.
	10 U.L.

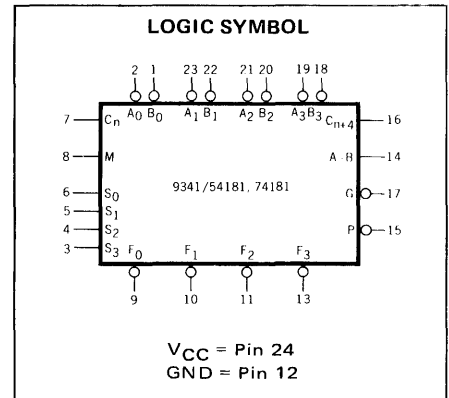

CONNECTION DIAGRAMS DIP (TOP VIEW)

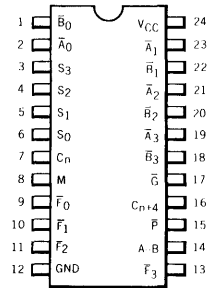

FLATPAK (TOP VIEW)

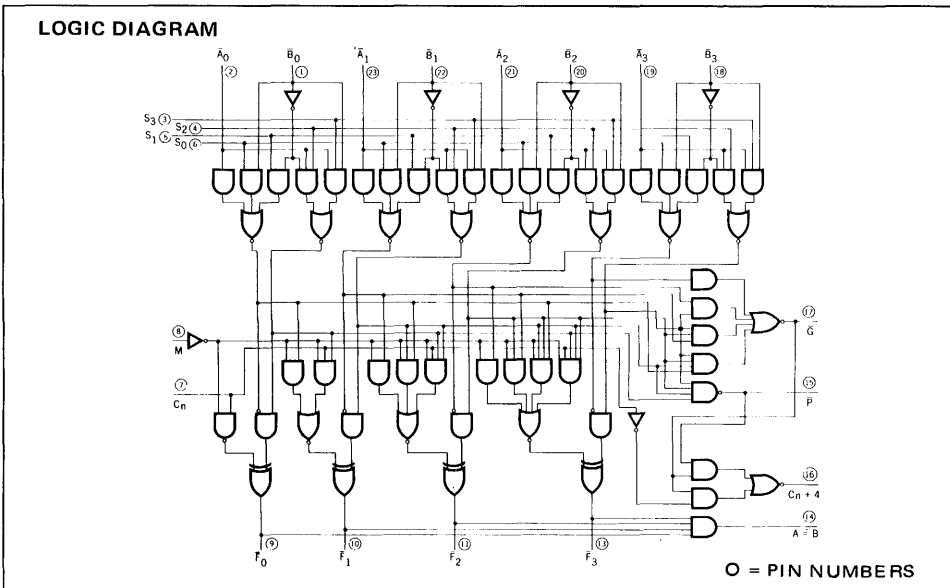
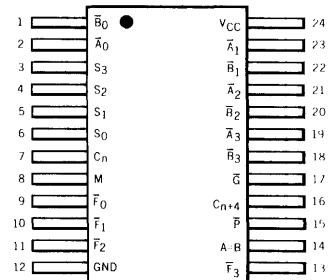

FUNCTIONAL DESCRIPTION – The TTL/MSI 9341/54181, 74181 is a 4-bit, high speed parallel Arithmetic Logic Unit (ALU). Controlled by the four Function Select Inputs ($S_0 \dots S_3$) and the Mode Control Input (M), it can perform all the 16 possible logic operations or 16 different arithmetic operations on active HIGH or active LOW operands. The Function Table below lists these operations.

When the Mode Control Input (M) is HIGH, all internal carries are inhibited and the device performs Logic operations on the individual bits as listed. When the Mode Control Input is LOW, the carries are enabled and the device performs Arithmetic operations on the two, 4-bit words. The device incorporates full internal look-ahead carry and provides for either ripple carry between devices using the C_{n+4} output, or for carry look-ahead between packages using the signals P (carry propagate) and G (carry generate). P and G are not affected by carry in. When speed requirements are not stringent, the 9341/54181, 74181 can be used in a simple ripple carry mode by connecting the carry out (C_{n+4}) signal to the carry in (C_n) of the next unit. For high speed operation the 9341/54181, 74181 is used in conjunction with the 9342/54182, 74182 carry look-ahead circuit. One carry look-ahead package is required for each group of four 9341/54181, 74181 devices. Carry look-ahead can be provided at various levels and offers high speed capability over extremely long word lengths.

The A = B output from the 9341/54181, 74181 goes HIGH when all four F outputs are HIGH and can be used to indicate logic equivalence over 4-bits when the unit is in the subtract mode. The A = B output is open collector and can be wire ANDed with other A = B outputs to give a comparison for more than 4-bits. The A = B signal can also be used with the carry out signal to indicate $A > B$ and $A < B$.

The Function Table lists the Arithmetic operations that are performed without a carry in. An incoming carry adds a one to each operation. Thus Select Code LHHH generates A minus B minus 1 (2's complement notation) without a carry in and generates A minus B when a carry is applied. Because subtraction is actually performed by complementary addition (1's complement), a CARRY OUT means BORROW; thus a carry is generated when there is no underflow and no carry is generated when there is underflow.

As indicated the 9341/54181, 74181 can be used with either active LOW inputs producing active LOW outputs or with active HIGH inputs producing active HIGH outputs. For either case the table lists the operations that are performed to the operands labeled inside the logic symbol.

FUNCTION TABLE

MODE SELECT INPUTS				ACTIVE LOW INPUTS & OUTPUTS		ACTIVE HIGH INPUTS & OUTPUTS	
S_3	S_2	S_1	S_0	LOGIC (M = H)	ARITHMETIC** (M = L) ($C_n = L$)	LOGIC (M = H)	ARITHMETIC** (M = L) ($C_n = H$)
L	L	L	L	\bar{A}	A minus 1	\bar{A}	A
L	L	L	H	$\bar{A}\bar{B}$	AB minus 1	$\bar{A} + \bar{B}$	A + B
L	L	H	L	$\bar{A} + \bar{B}$	AB plus 1	$\bar{A}\bar{B}$	A + \bar{B}
L	L	H	H	Logical 1	minus 1	Logical 0	minus 1
L	H	L	L	$\bar{A} + B$	A plus ($A + \bar{B}$)	$\bar{A}\bar{B}$	A plus $\bar{A}\bar{B}$
L	H	L	H	\bar{B}	AB plus ($A + \bar{B}$)	\bar{B}	(A + B) plus $\bar{A}\bar{B}$
L	H	H	L	$A \oplus \bar{B}$	A minus B minus 1	$A \oplus \bar{B}$	A minus B minus 1
L	H	H	H	$A + \bar{B}$	A + B	$\bar{A}\bar{B}$	$\bar{A}\bar{B}$ minus 1
H	L	L	L	$\bar{A}\bar{B}$	A plus ($A + B$)	$\bar{A} + \bar{B}$	A plus AB
H	L	L	H	$A \oplus B$	A plus B	$\bar{A} \oplus \bar{B}$	A plus B
H	L	H	L	B	$\bar{A}\bar{B}$ plus ($A + B$)	B	(A + B) plus AB
H	L	H	H	$A + B$	A + B	AB	AB minus 1
H	H	L	L	Logical 0	A plus A*	Logical 1	A plus A*
H	H	L	H	$\bar{A}\bar{B}$	$\bar{A}\bar{B}$ plus A	$A + \bar{B}$	(A + B) plus A
H	H	H	L	AB	$\bar{A}\bar{B}$ plus A	$A + B$	(A + B) plus A
H	H	H	H	A	A	A	A minus 1

LOGIC SYMBOLS

ACTIVE LOW OPERANDS

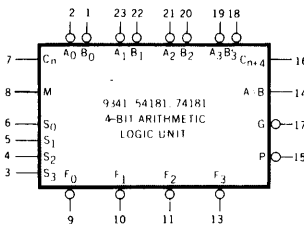

ACTIVE HIGH OPERANDS

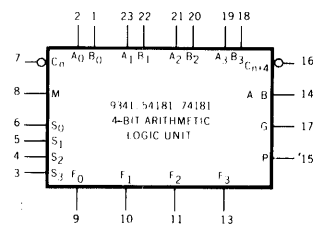

H = High Voltage Level
L = Low Voltage Level

V_{CC} = Pin 24
GND = Pin 12

*Each bit is shifted to the next more significant position
**Arithmetic operations expressed in 2's complement notation

TYPICAL INPUT AND OUTPUT CIRCUITS

INPUTS EQUIVALENT CIRCUIT

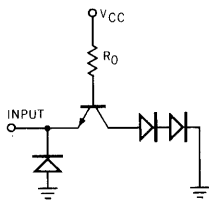

OUTPUTS EQUIVALENT CIRCUITS

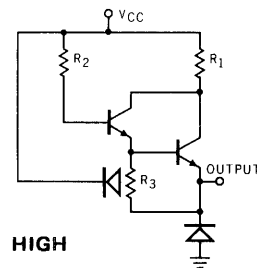
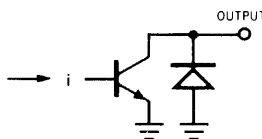

INPUT CURRENT VERSUS INPUT VOLTAGE

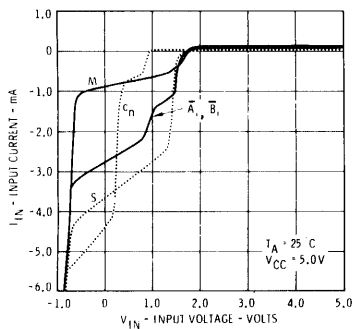

Fig. 1

OUTPUT CURRENT VERSUS OUTPUT VOLTAGE LOW STATE

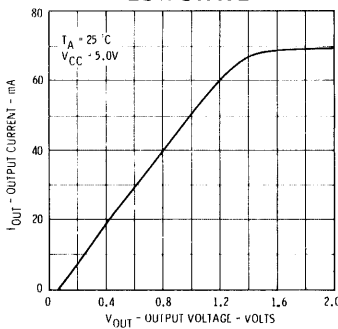

Fig. 2

OUTPUT CURRENT VERSUS OUTPUT VOLTAGE HIGH STATE

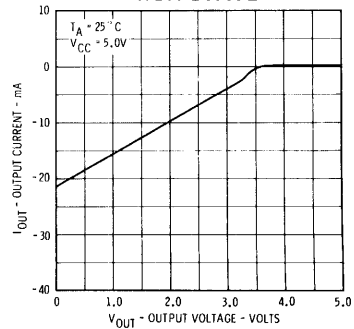

Fig. 3

FAIRCHILD TTL/MSI • 9341/54181, 74181

ABSOLUTE MAXIMUM RATINGS (above which the useful life may be impaired)

Storage Temperature	-65°C to +150°C
Temperature (Ambient) Under Bias	-55°C to +125°C
V _{CC} Pin Potential to Ground Pin	-0.5 V to +7.0 V
*Input Voltage (dc)	-0.5 V to +5.5 V
*Input Current (dc)	-30 mA to +5.0 mA
Voltage Applied to Outputs (Output HIGH)	-0.5 V to +V _{CC} value
Output Current (dc) (Output LOW)	+30 mA

*Either Input Voltage Limit or Input Current is sufficient to protect the inputs.

GUARANTEED OPERATING RANGES

PART NUMBER	SUPPLY VOLTAGE (V _{CC})			TEMPERATURE
	MIN.	TYP.	MAX.	
9341XM/54181XM	4.5 V	5.0 V	5.5 V	-55°C to 125°C
9341XC/74181XC	4.75 V	5.0 V	5.25 V	0°C to 75°C

X = package type; F for Flatpak, D for Ceramic Dip, P for Plastic Dip. See Packaging Information Section for packages available on this product.

ELECTRICAL CHARACTERISTICS OVER OPERATING TEMPERATURE RANGE (unless otherwise noted)

SYMBOL	PARAMETER	LIMITS		UNITS	CONDITIONS
		MIN.	MAX.		
V _{IH}	Input HIGH Voltage	2.0		V	Guaranteed Input HIGH Voltage for all Inputs
V _{IL}	Input LOW Voltage		0.8	V	Guaranteed Input LOW Voltage for all Inputs
V _{CD}	Input Clamp Diode Voltage		-1.5	V	V _{CC} = MIN., I _{IN} = -12 mA, T _A = 25°C
I _{CEX}	A = B Output Leakage Current (Open Collector)		250	μA	V _{CC} = MIN., V _{OUT} = 5.5 V
V _{OH}	Output HIGH Voltage	2.4		V	V _{CC} = MIN., I _{OH} = -800 μA V _{IN} = V _{IH} or V _{IL} per Truth Table
V _{OL}	Output LOW Voltage		0.4	V	V _{CC} = MIN., I _{OL} = 16 mA V _{IN} = V _{IH} or V _{IL} per Truth Table
I _{IH}	Input HIGH Current			μA	V _{CC} = MAX., V _{IN} = 2.4 V
	M		40		
	$\bar{A}_0 \bar{A}_1 \bar{A}_2 \bar{A}_3 \bar{B}_0 \bar{B}_1 \bar{B}_2 \bar{B}_3$		120		
	S ₀ S ₁ S ₂ S ₃		160		
	C _n		200		
	Input HIGH Current All Inputs		1.0	mA	V _{CC} = MAX., V _{IN} = 5.5 V
I _{IL}	Input LOW Current			mA	V _{CC} = MAX., V _{IN} = 0.4 V
	M		-1.6		
	$\bar{A}_0 \bar{A}_1 \bar{A}_2 \bar{A}_3 \bar{B}_0 \bar{B}_1 \bar{B}_2 \bar{B}_3$		-4.8		
	S ₀ S ₁ S ₂ S ₃		-6.4		
	C _n		-8.0		
I _{SC} (I _{OS})	Output Short Circuit Current (Note 4)	-20	-55	mA	V _{CC} = MAX., V _{OUT} = 0.0 V
		-18	-57	mA	
I _{CC}	Power Supply Current		127	mA	V _{CC} = MAX. C _n = B ₀ = B ₁ = B ₂ = B ₃ = GND All Other Inputs = 4.5 V
			140	mA	
			135	mA	V _{CC} = MAX. M = S ₀ = S ₁ = S ₂ = S ₃ = 4.5 V All Other Inputs = GND
			150	mA	

8

SWITCHING CHARACTERISTICS ($T_A = 25^\circ\text{C}$, $V_{CC} = 5.0\text{ V}$, Pin 12 = GND)

SYMBOL	PARAMETER	LIMITS		UNITS	CONDITIONS
		TYP.	MAX.		
t_{PLH} t_{PHL}	(C_n to $C_n + 4$)	12 13	16 17	ns	$M = 0\text{ V}$, (Sum or Diff Mode) See Fig. 4 and Tables I & II
t_{PLH} t_{PHL}	(C_n to \bar{F} outputs)	15 14	17 17	ns	$M = 0\text{ V}$, (Sum Mode) See Fig. 4 and Table I
t_{PLH} t_{PHL}	(\bar{A} or \bar{B} inputs to \bar{G} output)	16 9	19 12	ns	$M = S_1 = S_2 = 0\text{ V}$, $S_0 = S_3 = 4.5\text{ V}$ (Sum Mode) See Fig. 4 and Table I
t_{PLH} t_{PHL}	(\bar{A} or \bar{B} inputs to \bar{G} output)	18 13	22 17	ns	$M = S_0 = S_3 = 0\text{ V}$, $S_1 = S_2 = 4.5\text{ V}$ (Diff Mode) See Fig. 5 and Table II
t_{PLH} t_{PHL}	(\bar{A} or \bar{B} inputs to \bar{P} output)	16 11	19 15	ns	$M = S_1 = S_2 = 0\text{ V}$, $S_0 = S_3 = 4.5\text{ V}$ (Sum Mode) See Fig. 4 and Table I
t_{PLH} t_{PHL}	(\bar{A} or \bar{B} inputs to \bar{P} output)	17 14	21 21	ns	$M = S_0 = S_3 = 0\text{ V}$, $S_1 = S_2 = 4.5\text{ V}$ (Diff Mode) See Fig. 5 and Table II
t_{PLH} t_{PHL}	(\bar{A}_i or \bar{B}_i inputs to \bar{F}_i outputs)	19 19	26 26	ns	$M = S_1 = S_2 = 0\text{ V}$, $S_0 = S_3 = 4.5\text{ V}$ (Sum Mode) See Fig. 4 and Table I
t_{PLH} t_{PHL}	(\bar{A}_i or \bar{B}_i inputs to \bar{F}_i outputs)	20 26	26 32	ns	$M = S_0 = S_3 = 0\text{ V}$, $S_1 = S_2 = 4.5\text{ V}$ (Diff Mode) See Fig. 5 and Table II
t_{PLH} t_{PHL}	(\bar{A}_i or \bar{B}_i inputs to $\bar{F}_i + 1$ outputs)	23 19	29 25	ns	$M = 0\text{ V}$, $S_0 = S_3 = 4.5\text{ V}$, $S_1 = S_2 = 0\text{ V}$ (Sum Mode) See Fig. 4 and Table I
t_{PLH} t_{PHL}	(\bar{A}_i or \bar{B}_i inputs to $\bar{F}_i + 1$ outputs)	23 24	29 30	ns	$M = 0\text{ V}$, $S_0 = S_3 = 0\text{ V}$, $S_1 = S_2 = 4.5\text{ V}$ (Diff Mode) See Fig. 5 and Table II
t_{PLH} t_{PHL}	(\bar{A} or \bar{B} inputs to \bar{F} outputs)	18 19	24 24	ns	$M = 4.5\text{ V}$ (Logic Mode) See Fig. 4 and Table III
t_{PLH} t_{PHL}	(\bar{A} or \bar{B} inputs to $C_n + 4$ output)	16 26	21 30	ns	$M = 0\text{ V}$, $S_0 = S_3 = 4.5\text{ V}$, $S_1 = S_2 = 0\text{ V}$ (Sum Mode) See Fig. 6 and Table I
t_{PLH} t_{PHL}	(\bar{A} or \bar{B} inputs to $C_n + 4$ output)	19 26	25 30	ns	$M = 0\text{ V}$, $S_0 = S_3 = 0\text{ V}$, $S_1 = S_2 = 4.5\text{ V}$ (Diff Mode)
t_{PLH} t_{PHL}	(\bar{A} or \bar{B} inputs to $A = B$ output)	33 34	40 42	ns	$M = S_0 = S_3 = 0\text{ V}$, $S_1 = S_2 = 4.5\text{ V}$, $R_o = 400\ \Omega$ to 5.0 V (Diff Mode) See Fig. 5 and Table II

NOTES:

- (1) The actual testing procedures used to guarantee the Electrical Characteristics are contained in a detailed Customer Sample Specification. A copy of this specification can be obtained from Fairchild Digital Product Marketing, Mountain View, California.
- (2) Conditions for testing, not shown in the Table, are chosen to guarantee operation under "worst case" conditions.
- (3) The specified LIMITS represent the "worst case" value for the parameter. Since these "worst case" values normally occur at the temperature and supply voltage extremes, additional noise immunity and guard banding can be achieved by decreasing the allowable system operating ranges.
- (4) Note more than one output should be shorted at a time.

SWITCHING TIME WAVEFORMS

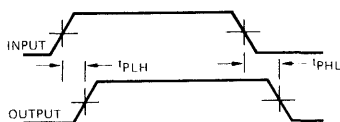

Fig. 4

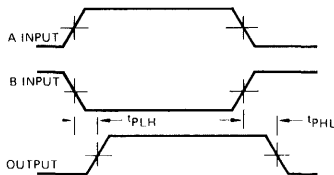

Fig. 5

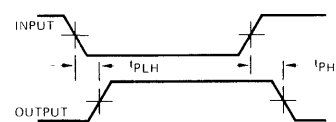

Fig. 6

SUM MODE TEST TABLE I

FUNCTION INPUTS: $S_0 = S_3 = 4.5\text{ V}$, $S_1 = S_2 = M = 0\text{ V}$

PARAMETER	INPUT UNDER TEST	OTHER INPUT SAME BIT		OTHER DATA INPUTS		OUTPUT UNDER TEST
		APPLY 4.5 V	APPLY GND	APPLY 4.5 V	APPLY GND	
t_{PLH} t_{PHL}	\bar{A}_i	\bar{B}_i	None	Remaining \bar{A} and \bar{B}	C_n	\bar{F}_i
t_{PLH} t_{PHL}	\bar{B}_i	\bar{A}_i	None	Remaining \bar{A} and \bar{B}	C_n	\bar{F}_i
t_{PLH} t_{PHL}	\bar{A}_i	\bar{B}_i	None	C_n	Remaining \bar{A} and \bar{B}	\bar{F}_{i+1}
t_{PLH} t_{PHL}	\bar{B}_i	\bar{A}_i	None	C_n	Remaining \bar{A} and \bar{B}	\bar{F}_{i+1}
t_{PLH} t_{PHL}	\bar{A}	\bar{B}	None	None	Remaining \bar{A} and \bar{B} , C_n	\bar{P}
t_{PLH} t_{PHL}	\bar{B}	\bar{A}	None	None	Remaining \bar{A} and \bar{B} , C_n	\bar{P}
t_{PLH} t_{PHL}	\bar{A}	None	\bar{B}	Remaining \bar{B}	Remaining \bar{A} , C_n	\bar{G}
t_{PLH} t_{PHL}	\bar{B}	None	\bar{A}	Remaining \bar{B}	Remaining \bar{A} , C_n	\bar{G}
t_{PLH} t_{PHL}	\bar{A}	None	\bar{B}	Remaining \bar{B}	Remaining \bar{A} , C_n	$C_n + 4$
t_{PLH} t_{PHL}	\bar{B}	None	\bar{A}	Remaining \bar{B}	Remaining \bar{A} , C_n	$C_n + 4$
t_{PLH} t_{PHL}	C_n	None	None	All \bar{A}	All \bar{B}	Any \bar{F} or $C_n + 4$

DIFF MODE TEST TABLE II

FUNCTION INPUTS: $S_1 = S_2 = 4.5\text{ V}$, $S_0 = S_3 = M = 0\text{ V}$

PARAMETER	INPUT UNDER TEST	OTHER INPUT SAME BIT		OTHER DATA INPUTS		OUTPUT UNDER TEST
		APPLY 4.5 V	APPLY GND	APPLY 4.5 V	APPLY GND	
t_{PLH} t_{PHL}	\bar{A}	None	\bar{B}	Remaining \bar{A}	Remaining \bar{B} , C_n	\bar{F}_i
t_{PLH} t_{PHL}	\bar{B}	\bar{A}	None	Remaining \bar{A}	Remaining \bar{B} , C_n	\bar{F}_i
t_{PLH} t_{PHL}	\bar{A}_i	None	\bar{B}_i	Remaining \bar{B} , C_n	Remaining \bar{A}	\bar{F}_{i+1}
t_{PLH} t_{PHL}	\bar{B}_i	\bar{A}_i	None	Remaining \bar{B} , C_n	Remaining \bar{A}	\bar{F}_{i+1}
t_{PLH} t_{PHL}	\bar{A}	None	\bar{B}	None	Remaining \bar{A} and \bar{B} , C_n	\bar{P}
t_{PLH} t_{PHL}	\bar{B}	\bar{A}	None	None	Remaining \bar{A} and \bar{B} , C_n	\bar{P}
t_{PLH} t_{PHL}	\bar{A}	\bar{B}	None	None	Remaining \bar{A} and \bar{B} , C_n	\bar{G}
t_{PLH} t_{PHL}	\bar{B}	None	\bar{A}	None	Remaining \bar{A} and \bar{B} , C_n	\bar{G}
t_{PLH} t_{PHL}	\bar{A}	None	\bar{B}	Remaining \bar{A}	Remaining \bar{B} , C_n	$A = B$
t_{PLH} t_{PHL}	\bar{B}	\bar{A}	None	Remaining \bar{A}	Remaining \bar{B} , C_n	$A = B$
t_{PLH} t_{PHL}	\bar{A}	\bar{B}	None	None	Remaining \bar{A} and \bar{B} , C_n	$C_n + 4$
t_{PLH} t_{PHL}	\bar{B}	None	\bar{A}	None	Remaining \bar{A} and \bar{B} , C_n	$C_n + 4$
t_{PLH} t_{PHL}	C_n	None	None	All \bar{A} and \bar{B}	None	$C_n + 4$

LOGIC MODE TEST TABLE III

PARAMETER	INPUT UNDER TEST	OTHER INPUT SAME BIT		OTHER DATA INPUTS		OUTPUT UNDER TEST	FUNCTION INPUTS
		APPLY 4.5 V	APPLY GND	APPLY 4.5 V	APPLY GND		
t_{PLH} t_{PHL}	\bar{A}	None	\bar{B}	None	Remaining \bar{A} and \bar{B} , C_n	Any \bar{F}	$S_1 = S_3 = M = 4.5\text{ V}$ $S_0 = S_2 = 0\text{ V}$
t_{PLH} t_{PHL}	\bar{B}	None	\bar{A}	None	Remaining \bar{A} and \bar{B} , C_n	Any \bar{F}	$S_1 = S_3 = M = 4.5\text{ V}$ $S_0 = S_2 = 0\text{ V}$

TTL/MSI 93S41

4-BIT ARITHMETIC LOGIC UNIT

DESCRIPTION — The TTL/MSI 93S41 is a 4-bit high speed Arithmetic Logic Unit (ALU) which can perform all the possible 16 logic operations on two variables and a variety of arithmetic operations; the Add and Subtract modes are the most important. The ALU is fully compatible with all members of the Fairchild TTL family and incorporates the Schottky TTL process to achieve super high speeds.

- PROVIDES 16 ARITHMETIC OPERATIONS
ADD, SUBTRACT, COMPARE, DOUBLE, PLUS
TWELVE OTHER ARITHMETIC OPERATIONS
- PROVIDES ALL 16 LOGIC OPERATIONS OF TWO VARIABLES
EXCLUSIVE-OR, COMPARE, AND, NAND, OR, NOR, PLUS
TEN OTHER LOGIC OPERATIONS
- FULL LOOKAHEAD FOR HIGH SPEED ARITHMETIC OPERATION ON LONG WORDS
- INPUT CLAMP DIODES
- TYPICAL ADD TIME FOR 16-BITS IS 19ns
- TYPICAL POWER DISSIPATION OF 500mW

PIN NAMES

\bar{A}_0 to \bar{A}_3 , \bar{B}_0 to \bar{B}_3	Operand (Active LOW) Inputs
S_0, S_1, S_2, S_3	Function — Select Inputs
M	Mode Control Input
C_n	Carry Input
$\bar{F}_0, \bar{F}_1, \bar{F}_2, \bar{F}_3$	Function (Active LOW) Outputs
A = B	Comparator Output
\bar{G}	Carry Generate (Active LOW) Output
\bar{P}	Carry Propagate (Active LOW) Output
C_{n+4}	Carry Output

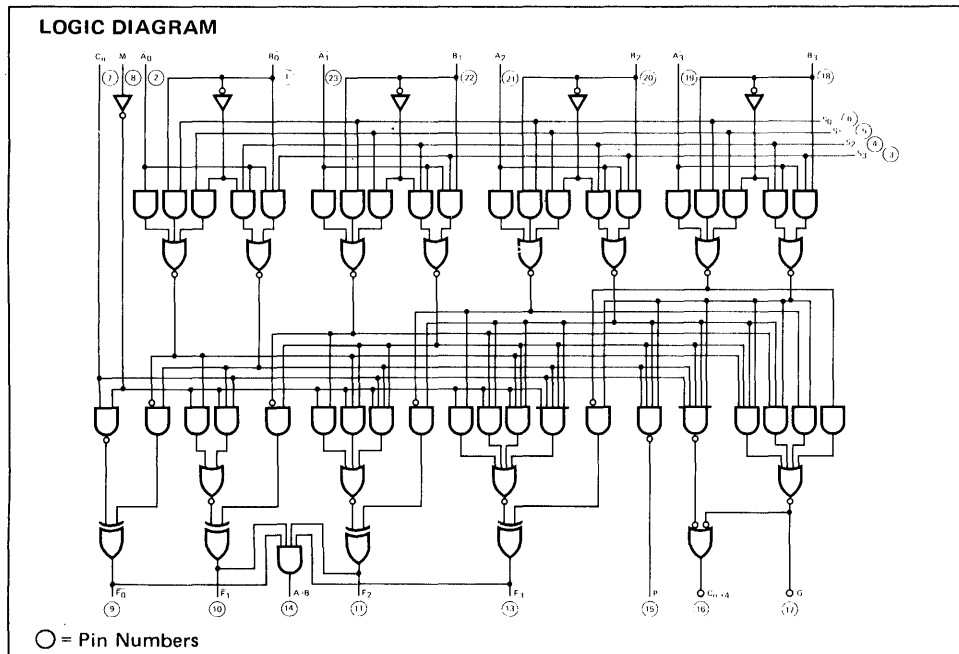

LOGIC SYMBOL

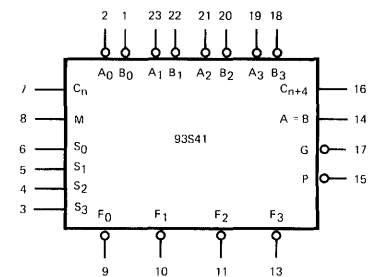

V_{CC} = PIN 24
GND = PIN 12

CONNECTION DIAGRAMS DIP (TOP VIEW)

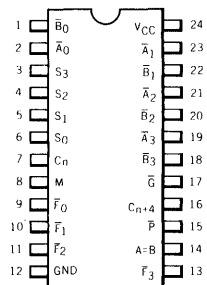

FLATPAK (TOP VIEW)

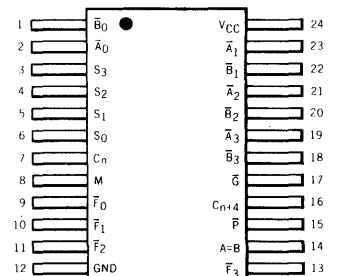

FUNCTIONAL DESCRIPTION – The TTL/MSI 93S41 is a 4-bit super high speed parallel Arithmetic Logic Unit (ALU). Controlled by the four Function Select Inputs ($S_0 \dots S_3$) and the Mode Control Input (M), it can perform all the 16 possible logic operations or 16 different arithmetic operations on active HIGH or active LOW operands. The Function Table below lists these operations.

When the Mode Control Input (M) is HIGH, all internal carries are inhibited and the device performs Logic operations on the individual bits as listed. When the Mode Control Input is LOW, the carries are enabled and the device performs Arithmetic operations on the two, 4-bit words. The device incorporates full internal look-ahead carry and provides for either ripple carry between devices using the C_{n+4} output, or for carry look-ahead between packages using the signals P (carry propagate) and G (carry generate). P and G are not affected by carry in. When speed requirements are not stringent, the 93S41 can be used in a simple ripple carry mode by connecting the carry out (C_{n+4}) signal to the carry input (C_n) of the next unit. For high speed operation the 93S41 is used in conjunction with the 93S42 carry look-ahead circuit. One carry look-ahead package is required for each group of four 93S41 devices. Carry look-ahead can be provided at various levels and offers high speed capability over extremely long word lengths.

The A = B output from the 93S41 goes HIGH when all four F outputs are HIGH and can be used to indicate logic equivalence over 4-bits when the unit is in the subtract mode. The A = B output is open collector and can be wire ANDed with other A = B outputs to give a comparison for more than 4-bits. The A = B signal can also be used with the carry out signal to indicate $A > B$ and $A < B$.

The Function Table lists the Arithmetic operations that are performed without a carry in. An incoming carry adds a one to each operation. Thus Select Code LHHH generates A minus B minus 1 (2's complement notation) without a carry in and generates A minus B when a carry is applied. Because subtraction is actually performed by complementary addition (1's complement), a CARRY OUT means BORROW; thus a carry is generated when there is no underflow and no carry is generated when there is underflow.

As indicated the 93S41 can be used with either active LOW inputs producing active LOW outputs or with active HIGH inputs producing active HIGH outputs. For either case the table lists the operations that are performed to the operands labeled inside the logic symbol.

FUNCTION TABLE

MODE SELECT INPUTS $S_3 S_2 S_1 S_0$	ACTIVE LOW INPUTS & OUTPUTS		ACTIVE HIGH INPUTS & OUTPUTS	
	LOGIC (M = H)	ARITHMETIC** (M = L) ($C_n = L$)	LOGIC (M = H)	ARITHMETIC** (M = L) ($C_n = H$)
L L L L	\bar{A}	A minus 1	\bar{A}	A
L L L H	$\bar{A}\bar{B}$	AB minus 1	$\bar{A} + \bar{B}$	A + B
L L H L	$\bar{A} + \bar{B}$	$\bar{A}\bar{B}$ minus 1	$\bar{A}\bar{B}$	A + \bar{B}
L L H H	\bar{B}	Logical 1 minus 1	Logical 0	minus 1
L H L L	$\bar{A} + \bar{B}$	A plus ($A + \bar{B}$)	$\bar{A}\bar{B}$	A plus $\bar{A}\bar{B}$
L H L H	\bar{B}	AB plus ($A + \bar{B}$)	\bar{B}	(A + B) plus $\bar{A}\bar{B}$
L H H L	$\bar{A} \odot \bar{B}$	A minus B minus 1	$\bar{A} \odot B$	A minus B minus 1
L H H H	$\bar{A} + \bar{B}$	A + B	$\bar{A}\bar{B}$	AB minus 1
H L L L	$\bar{A}\bar{B}$	A plus ($A + B$)	$\bar{A} + \bar{B}$	A plus AB
H L L H	$\bar{A} \odot B$	A plus B	$\bar{A} \odot \bar{B}$	A plus B
H L H L	B	$\bar{A}\bar{B}$ plus ($A + B$)	B	(A + \bar{B}) plus AB
H L H H	A + B	A + B	AB	AB minus 1
H H L L	Logical 0	A plus A*	Logical 1	A plus A*
H H L H	$\bar{A}\bar{B}$	AB plus A	$\bar{A} + \bar{B}$	(A + \bar{B}) plus A
H H H L	AB	$\bar{A}\bar{B}$ plus A	A + B	(A + \bar{B}) plus A
H H H H	A	A	A	A minus 1

LOGIC SYMBOLS

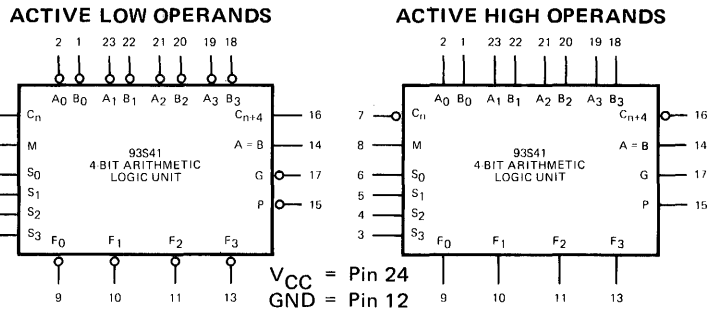

L = LOW Voltage Level
H = HIGH Voltage Level
*Each bit is shifted to the next more significant position
**Arithmetic operations expressed in 2's complement notation

TYPICAL INPUT AND OUTPUT CIRCUITS

INPUTS EQUIVALENT CIRCUIT

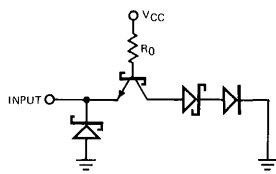

OUTPUTS EQUIVALENT CIRCUIT

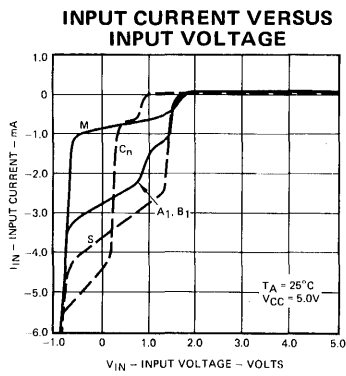
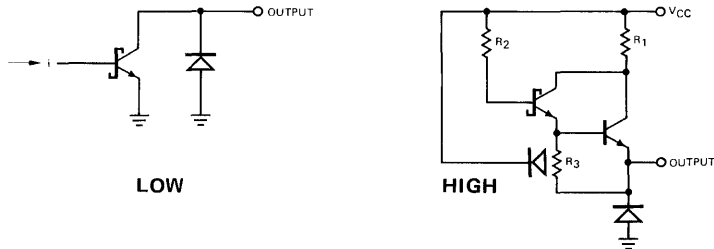

Fig. 1

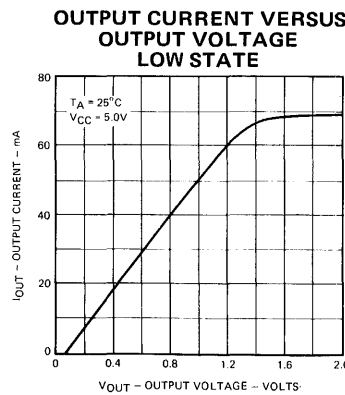

Fig. 2

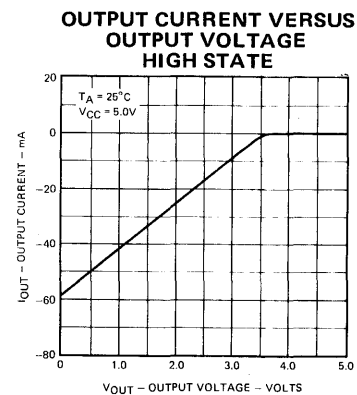

Fig. 3

FAIRCHILD TTL/MSI • 93S41

ABSOLUTE MAXIMUM RATINGS (above which the useful life may be impaired)

Storage Temperature	-65°C to +150°C
Temperature (Ambient) Under Bias	-55°C to +125°C
V _{CC} Pin Potential to Ground Pin	-0.5 V to +7.0 V
*Input Voltage (dc)	-0.5 V to +5.5 V
*Input Current (dc)	-30 mA to +5.0 mA
Voltage Applied to Outputs (Output HIGH)	-0.5 V to +V _{CC} value
Output Current (dc) (Output LOW)	+30 mA

*Either Input Voltage Limit or Input Current is sufficient to protect the inputs.

GUARANTEED OPERATING RANGES

PART NUMBER	SUPPLY VOLTAGE (V _{CC})			TEMPERATURE
	MIN.	TYP.	MAX.	
93S41XM	4.5 V	5.0 V	5.5 V	-55°C to 125°C
93S41XC	4.75 V	5.0 V	5.25 V	0°C to 75°C

X = package type; F for Flatpak, D for Ceramic Dip, P for Plastic Dip. See Packaging Information Section for packages available on this product.

ELECTRICAL CHARACTERISTICS OVER OPERATING TEMPERATURE RANGE (unless otherwise noted)

SYMBOL	PARAMETER	LIMITS			UNITS	CONDITIONS	
		MIN.	TYP.	MAX.			
V _{IH}	Input HIGH Voltage	2.0			Volts	Guaranteed Input HIGH Voltage for all Inputs	
V _{IL}	Input LOW Voltage			0.8	Volts	Guaranteed Input LOW Voltage for all Inputs	
V _{CD}	Input Clamp Diode Voltage			-1.2	Volts	V _{CC} = MIN., I _{IN} = -18 mA, T _A = 25°C	
I _{CEX}	A = B Output Leakage Current (Open Collector)			250	μA	V _{CC} = MIN., V _{OUT} = 5.5 V	
V _{OH}	Output HIGH Voltage	2.5			Volts	V _{CC} = MIN., I _{OH} = -1.0 mA V _{IN} = V _{IH} or V _{IL} per Truth Table	
		2.7					
V _{OL}	Output LOW Voltage			0.5	Volts	V _{CC} = MIN., I _{OL} = 20 mA V _{IN} = V _{IH} or V _{IL} per Truth Table	
I _{IH}	Input HIGH Current				μA	V _{CC} = MAX., V _{IN} = 2.7 V	
	M			50			
	$\bar{A}_0 \bar{A}_1 \bar{A}_2 \bar{A}_3 \bar{B}_0 \bar{B}_1 \bar{B}_2 \bar{B}_3$			150			
	S ₀ S ₁ S ₂ S ₃			200			
	C _n			300			
	Input HIGH Current All Inputs			1.0	mA	V _{CC} = MAX., V _{IN} = 5.5 V	
I _{IL}	Input LOW Current				mA	V _{CC} = MAX., V _{IN} = 0.4 V	
	M			-1.6			
	$\bar{A}_0 \bar{A}_1 \bar{A}_2 \bar{A}_3 \bar{B}_0 \bar{B}_1 \bar{B}_2 \bar{B}_3$			-4.8			
	S ₀ S ₁ S ₂ S ₃			-6.4			
	C _n			-9.6			
I _{SC} (I _{OS})	Output Short Circuit Current (Note 4)	-40		-100	mA	V _{CC} = MAX., V _{OUT} = 0 V	
I _{CC}	Power Supply Current		95	125	mA	V _{CC} = MAX., C _n = B ₀ =B ₁ =B ₂ =B ₃ =GND All Other Inputs = 4.5 V	
			95	140	mA		XC
			105	135	mA		XM
			105	150	mA		XC

FAIRCHILD TTL/MSI • 93S41

SWITCHING CHARACTERISTICS ($T_A = 25^\circ\text{C}$, $V_{CC} = 5.0\text{ V}$, Pin 12 = GND)

SYMBOL	PARAMETER	LIMITS		UNITS	CONDITIONS
		TYP.	MAX.		
t _{PLH} t _{PHL}	(C_n to C_{n+4})	7.0 7.0	12 12	ns	$M = 0\text{ V}$, (Sum or Diff Mode) See Fig. 4 and Tables I & II
t _{PLH} t _{PHL}	(C_n to \bar{F} outputs)	7.0 7.0	12 12	ns	$M = 0\text{ V}$, (Sum Mode) See Fig. 4 and Table I
t _{PLH} t _{PHL}	(\bar{A} or \bar{B} inputs to \bar{G} output)	9.5 7.0	14 14	ns	$M = S_1 = S_2 = 0\text{ V}$, $S_0 = S_3 = 4.5\text{ V}$ (Sum Mode) See Fig. 4 and Table I
t _{PLH} t _{PHL}	(\bar{A} or \bar{B} inputs to \bar{G} output)	9.5 9.0	15 15	ns	$M = S_0 = S_3 = 0\text{ V}$, $S_1 = S_2 = 4.5\text{ V}$ (Diff Mode) See Fig. 5 and Table II
t _{PLH} t _{PHL}	(\bar{A} or \bar{B} inputs to \bar{P} output)	8.5 8.0	14 14	ns	$M = S_1 = S_2 = 0\text{ V}$, $S_0 = S_3 = 4.5\text{ V}$ (Sum Mode) See Fig. 4 and Table I
t _{PLH} t _{PHL}	(\bar{A} or \bar{B} inputs to \bar{P} output)	8.5 10	15 15	ns	$M = S_0 = S_3 = 0\text{ V}$, $S_1 = S_2 = 4.5\text{ V}$ (Diff Mode) See Fig. 5 and Table II
t _{PLH} t _{PHL}	(\bar{A} or \bar{B} inputs to any \bar{F} output)	15 9.0	20 20	ns	$M = S_1 = S_2 = 0\text{ V}$, $S_0 = S_3 = 4.5\text{ V}$ (Sum Mode) See Fig. 4 and Table I
t _{PLH} t _{PHL}	(\bar{A} or \bar{B} inputs to any \bar{F} output)	14 11	21 21	ns	$M = S_0 = S_3 = 0\text{ V}$, $S_1 = S_2 = 4.5\text{ V}$ (Diff Mode) See Fig. 5 and Table II
t _{PLH} t _{PHL}	(\bar{A} or \bar{B} inputs to \bar{F} outputs)	10 10	20 20	ns	$M = 4.5\text{ V}$ (Logic Mode) See Fig. 4 and Table III
t _{PLH} t _{PHL}	(\bar{A} or \bar{B} inputs to C_{n+4} output)	10 13	18.5 18.5	ns	$M = 0\text{ V}$, $S_0 = S_3 = 4.5\text{ V}$, $S_1 = S_2 = 0\text{ V}$ (Sum Mode) See Fig. 6 and Table I
t _{PLH} t _{PHL}	(\bar{A} or \bar{B} inputs to C_{n+4} output)	12 13	23 23	ns	$M = 0\text{ V}$, $S_0 = S_3 = 0\text{ V}$, $S_1 = S_2 = 4.5\text{ V}$ (Diff Mode)
t _{PLH}	(\bar{A} or \bar{B} inputs to $A = B$ output)	13	23	ns	$M = S_0 = S_3 = 0\text{ V}$, $S_1 = S_2 = 4.5\text{ V}$, $R_O = 400\ \Omega$ to 5.0 V
t _{PHL}		13	23		(Diff Mode) See Fig. 5 and Table II

NOTES:

1. The actual testing procedures used to guarantee the Electrical Characteristics are contained in a detailed Customer Sample Specification. A copy of this specification can be obtained from Fairchild Digital Product Marketing, Mountain View, California.
2. Conditions for testing, not shown in the Table, are chosen to guarantee operation under "worst case" conditions.
3. The specified LIMITS represent the "worst case" value for the parameter. Since these "worst case" values normally occur at the temperature and supply voltage extremes, additional noise immunity and guard banding can be achieved by decreasing the allowable system operating ranges.
4. Not more than one output should be shorted at a time.

SWITCHING TIME WAVEFORMS

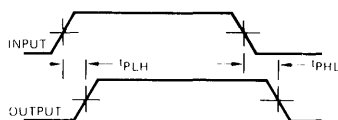

Fig. 4

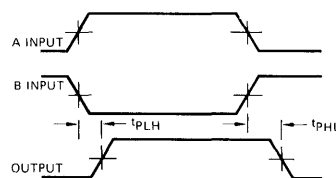

Fig. 5

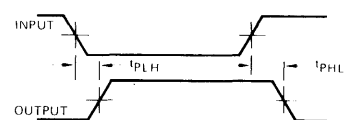

Fig. 6

FAIRCHILD TTL/MSI • 93S41

SUM MODE TEST TABLE I

FUNCTION INPUTS: $S_0 = S_3 = 4.5\text{ V}$, $S_1 = S_2 = M = 0\text{ V}$

PARAMETER	INPUT UNDER TEST	OTHER INPUT SAME BIT		OTHER DATA INPUTS		OUTPUT UNDER TEST
		APPLY 4.5 V	APPLY GND	APPLY 4.5 V	APPLY GND	
t_{PLH} t_{PHL}	\bar{A}_i	\bar{B}_i	None	Remaining \bar{A} and \bar{B}	C_n	\bar{F}_i
t_{PLH} t_{PHL}	\bar{B}_i	\bar{A}_i	None	Remaining \bar{A} and \bar{B}	C_n	\bar{F}_i
t_{PLH} t_{PHL}	\bar{A}_i	\bar{B}_i	None	C_n	Remaining \bar{A} and \bar{B}	\bar{F}_{i+1}
t_{PLH} t_{PHL}	\bar{B}_i	\bar{A}_i	None	C_n	Remaining \bar{A} and \bar{B}	\bar{F}_{i+1}
t_{PLH} t_{PHL}	\bar{A}	\bar{B}	None	None	Remaining \bar{A} and \bar{B} , C_n	\bar{P}
t_{PLH} t_{PHL}	\bar{B}	\bar{A}	None	None	Remaining \bar{A} and \bar{B} , C_n	\bar{P}
t_{PLH} t_{PHL}	\bar{A}	None	\bar{B}	Remaining \bar{B}	Remaining \bar{A} , C_n	\bar{G}
t_{PLH} t_{PHL}	\bar{B}	None	\bar{A}	Remaining \bar{B}	Remaining \bar{A} , C_n	\bar{G}
t_{PLH} t_{PHL}	\bar{A}	None	\bar{B}	Remaining \bar{B}	Remaining \bar{A} , C_n	$C_n + 4$
t_{PLH} t_{PHL}	\bar{B}	None	\bar{A}	Remaining \bar{B}	Remaining \bar{A} , C_n	$C_n + 4$
t_{PLH} t_{PHL}	C_n	None	None	All \bar{A}	All \bar{B}	Any \bar{F} or $C_n + 4$

DIFF MODE TEST TABLE II

FUNCTION INPUTS: $S_1 = S_2 = 4.5\text{ V}$, $S_0 = S_3 = M = 0\text{ V}$

PARAMETER	INPUT UNDER TEST	OTHER INPUT SAME BIT		OTHER DATA INPUTS		OUTPUT UNDER TEST
		APPLY 4.5 V	APPLY GND	APPLY 4.5 V	APPLY GND	
t_{PLH} t_{PHL}	\bar{A}	None	\bar{B}	Remaining \bar{A}	Remaining \bar{B} , C_n	\bar{F}_i
t_{PLH} t_{PHL}	\bar{B}	\bar{A}	None	Remaining \bar{A}	Remaining \bar{B} , C_n	\bar{F}_i
t_{PLH} t_{PHL}	\bar{A}_i	None	\bar{B}_i	Remaining \bar{B} , C_n	Remaining \bar{A}	\bar{F}_{i+1}
t_{PLH} t_{PHL}	\bar{B}_i	\bar{A}_i	None	Remaining \bar{B} , C_n	Remaining \bar{A}	\bar{F}_{i+1}
t_{PLH} t_{PHL}	\bar{A}	None	\bar{B}	None	Remaining \bar{A} and \bar{B} , C_n	\bar{P}
t_{PLH} t_{PHL}	\bar{B}	\bar{A}	None	None	Remaining \bar{A} and \bar{B} , C_n	\bar{P}
t_{PLH} t_{PHL}	\bar{A}	\bar{B}	None	None	Remaining \bar{A} and \bar{B} , C_n	\bar{G}
t_{PLH} t_{PHL}	\bar{B}	None	\bar{A}	None	Remaining \bar{A} and \bar{B} , C_n	\bar{G}
t_{PLH} t_{PHL}	\bar{A}	None	\bar{B}	Remaining \bar{A}	Remaining \bar{B} , C_n	$A = B$
t_{PLH} t_{PHL}	\bar{B}	\bar{A}	None	Remaining \bar{A}	Remaining \bar{B} , C_n	$A = B$
t_{PLH} t_{PHL}	\bar{A}	\bar{B}	None	None	Remaining \bar{A} and \bar{B} , C_n	$C_n + 4$
t_{PLH} t_{PHL}	\bar{B}	None	\bar{A}	None	Remaining \bar{A} and \bar{B} , C_n	$C_n + 4$
t_{PLH} t_{PHL}	C_n	None	None	All \bar{A} and \bar{B}	None	$C_n + 4$

LOGIC MODE TEST TABLE III

PARAMETER	INPUT UNDER TEST	OTHER INPUT SAME BIT		OTHER DATA INPUTS		OUTPUT UNDER TEST	FUNCTION INPUTS
		APPLY 4.5 V	APPLY GND	APPLY 4.5 V	APPLY GND		
t_{PLH} t_{PHL}	\bar{A}	None	\bar{B}	None	Remaining \bar{A} and \bar{B} , C_n	Any \bar{F}	$S_1 = S_3 = M = 4.5\text{ V}$ $S_0 = S_2 = 0\text{ V}$
t_{PLH} t_{PHL}	\bar{B}	None	\bar{A}	None	Remaining \bar{A} and \bar{B} , C_n	Any \bar{F}	$S_1 = S_3 = M = 4.5\text{ V}$ $S_0 = S_2 = 0\text{ V}$

TTL/MSI 9342/54182, 74182

LOOKAHEAD CARRY GENERATOR

DESCRIPTION — The TTL/MSI 9342/54182, 74182 is a high speed Lookahead Carry Generator. It is generally used with the 9341/54181, 74181 4-Bit Arithmetic Logic Unit to provide high speed lookahead over word lengths of more than four bits. The lookahead carry generator is fully compatible with all members of the Fairchild TTL Family.

- PROVIDES LOOKAHEAD CARRIES ACROSS A GROUP OF FOUR ALU'S
- MULTI-LEVEL LOOKAHEAD FOR HIGH SPEED ARITHMETIC OPERATION OVER LONG WORD LENGTHS
- INPUT CLAMP DIODES
- TTL COMPATIBLE

PIN NAMES

C_n
 $\overline{G}_0, \overline{G}_2$
 \overline{G}_1
 \overline{G}_3
 $\overline{P}_0, \overline{P}_1$
 \overline{P}_2
 \overline{P}_3
 $C_{n+x}, C_{n+y}, C_{n+z}$
 \overline{G}
 \overline{P}

Carry Input
 Carry Generate (Active LOW) Inputs
 Carry Generate (Active LOW) Input
 Carry Generate (Active LOW) Input
 Carry Propagate (Active LOW) Inputs
 Carry Propagate (Active LOW) Input
 Carry Propagate (Active LOW) Input
 Carry Outputs (Note b)
 Carry Generate (Active LOW) Output (Note b)
 Carry Propagate (Active LOW) Output (Note b)

LOADING

(Note a)
 1 U.L.
 7 U.L.
 8 U.L.
 4 U.L.
 4 U.L.
 3 U.L.
 2 U.L.
 10 U.L.
 10 U.L.
 10 U.L.

Notes:

- (a) 1 Unit Load (U.L.) = 40 μ A HIGH/1.6 mA LOW
 (b) 10 U.L. is the output LOW drive factor and 20 U.L. is the output HIGH drive factor.

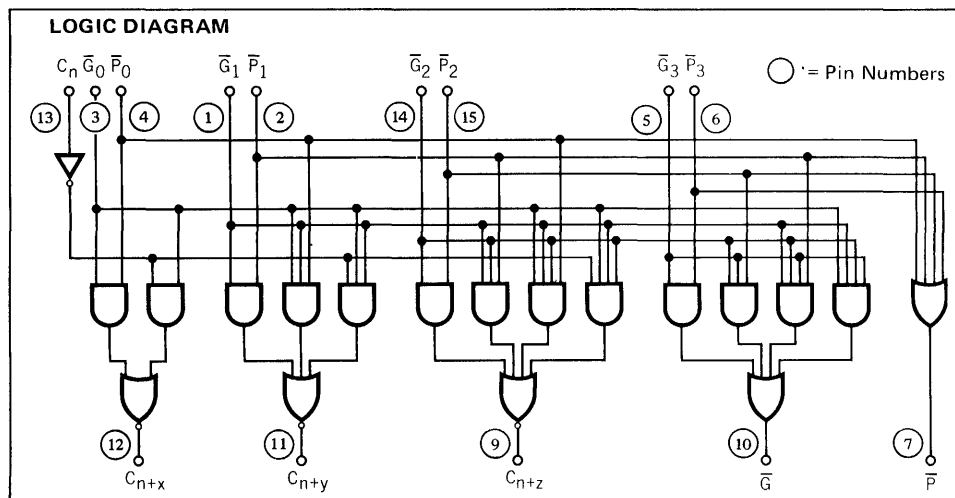

LOGIC SYMBOL

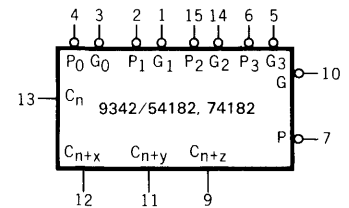

V_{CC} = Pin 16
 GND = Pin 8

CONNECTION DIAGRAMS DIP (TOP VIEW)

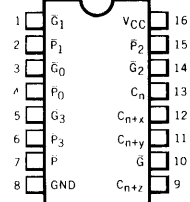

FLATPAK (TOP VIEW)

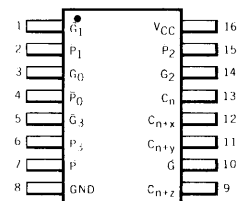

FUNCTIONAL DESCRIPTION – The TTL/MSI 9342/54182, lookahead carry generator accepts up to four pairs of active LOW Carry Propagate ($\overline{P}_0, \overline{P}_1, \overline{P}_2, \overline{P}_3$) and Carry Generate ($\overline{G}_0, \overline{G}_1, \overline{G}_2, \overline{G}_3$) signals and an active HIGH Carry Input (C_n) and provides anticipated active HIGH carries ($C_{n+x}, C_{n+y}, C_{n+z}$) across four groups of binary adders. The 9342/54182, 74182 also has active LOW Carry Propagate (\overline{P}) and Carry Generate (\overline{G}) outputs which may be used for further levels of lookahead.

The logic equations provided at the outputs are:

$$C_{n+x} = G_0 + P_0 C_n$$

$$C_{n+y} = G_1 + P_1 G_0 + P_1 P_0 C_n$$

$$C_{n+z} = G_2 + P_2 G_1 + P_2 P_1 G_0 + P_2 P_1 P_0 C_n$$

$$\overline{G} = \overline{G_3} + P_3 \overline{G_2} + P_3 P_2 \overline{G_1} + P_3 P_2 P_1 \overline{G_0}$$

$$\overline{P} = \overline{P_3 P_2 P_1 P_0}$$

Also, the 9342/54182, 74182 can be used with binary ALU's in an active LOW or active HIGH input operand mode. The connections to and from the ALU to the lookahead carry generator are identical in both cases.

TRUTH TABLE

INPUTS							OUTPUTS						
C_n	\overline{G}_0	\overline{P}_0	\overline{G}_1	\overline{P}_1	\overline{G}_2	\overline{P}_2	\overline{G}_3	\overline{P}_3	C_{n+x}	C_{n+y}	C_{n+z}	\overline{G}	\overline{P}
X	H	H							L	L	L	L	L
L	H	X							L	L	L	L	L
X	L	X							H	H	H	H	H
H	X	L							H	H	H	H	H
X	X	X	H	H					L	L	L	L	L
X	H	H	H	X					L	L	L	L	L
L	H	X	H	X					L	L	L	L	L
X	X	X	L	X					H	H	H	H	H
X	L	X	L	X					H	H	H	H	H
H	X	L	X	L					H	H	H	H	H
X	X	X	X	H	H				L	L	L	L	L
X	X	H	H	H	X				L	L	L	L	L
X	H	H	H	X	H	X			L	L	L	L	L
L	H	X	H	X	H	X			L	L	L	L	L
X	X	X	X	L	X	L			H	H	H	H	H
X	X	L	X	L	X	L			H	H	H	H	H
X	L	X	L	X	L	X			H	H	H	H	H
H	X	L	X	L	X	L			H	H	H	H	H
X	X	X	X	X	H	H			H	H	H	H	H
X	X	X	H	H	H	X			H	H	H	H	H
X	H	H	H	X	H	X			H	H	H	H	H
X	X	X	X	X	L	X			L	L	L	L	L
X	X	X	L	X	X	L			L	L	L	L	L
X	L	X	L	X	L	X			L	L	L	L	L
L	X	L	X	L	X	L			L	L	L	L	L
H	X	X	X	X					H	H	H	H	H
X	H	X	X	X					H	H	H	H	H
X	X	H	X	X					H	H	H	H	H
X	X	X	H	X					H	H	H	H	H
X	X	X	X	H					H	H	H	H	H
L	L	L	L	L					L	L	L	L	L

H = HIGH Voltage Level
L = LOW Voltage Level
X = Don't Care

TYPICAL INPUT AND OUTPUT CHARACTERISTICS

EQUIVALENT INPUT CIRCUIT

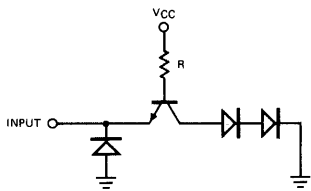

INPUT CURRENT VERSUS INPUT VOLTAGE

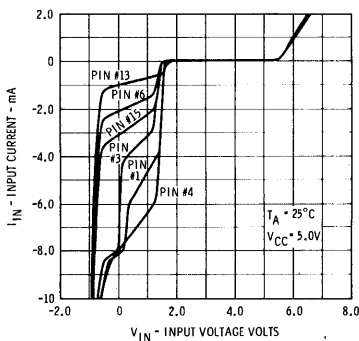

OUTPUT HIGH EQUIVALENT CIRCUIT

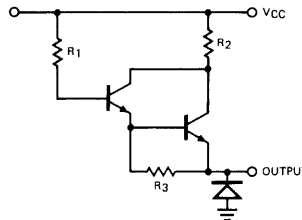

OUTPUT CURRENT VERSUS OUTPUT VOLTAGE (OUTPUT HIGH)

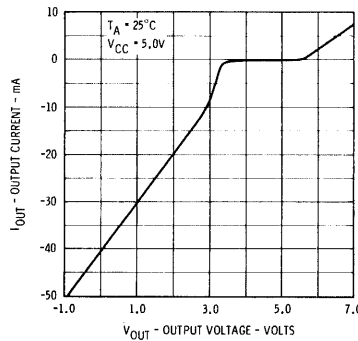

OUTPUT LOW EQUIVALENT CIRCUIT

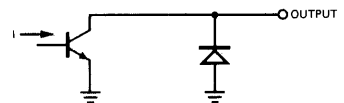

OUTPUT CURRENT VERSUS OUTPUT VOLTAGE (OUTPUT LOW)

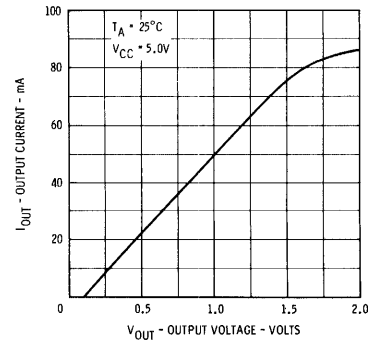

TTL/MSI • 9342/54182, 74182

ABSOLUTE MAXIMUM RATINGS (above which the useful life may be impaired)

Storage Temperature	-65°C to +150°C
Temperature (Ambient) Under Bias	-55°C to +125°C
V _{CC} Pin Potential to Ground Pin	-0.5 V to +7.0 V
*Input Voltage (dc)	-0.5 V to +5.5 V
*Input Current (dc)	-30 mA to +5.0 mA
Voltage Applied to Outputs (Output HIGH)	-0.5 V to +V _{CC} value
Output Current (dc) (Output LOW)	+30 mA

*Either Input Voltage limit or Input Current limit is sufficient to protect the inputs.

GUARANTEED OPERATING RANGES

PART NUMBER	SUPPLY VOLTAGE (V _{CC})			TEMPERATURE
	MIN.	TYP.	MAX.	
9342XM/54182XM	4.5 V	5.0 V	5.5 V	-55°C to 125°C
9342XC/74182XC	4.75 V	5.0 V	5.25 V	0°C to 75°C

X = package type; F for Flatpak, D for Ceramic Dip, P for Plastic Dip. See Packaging Information Section for packages available on this product.

ELECTRICAL CHARACTERISTICS OVER OPERATING TEMPERATURE RANGE (unless otherwise noted)

SYMBOL	PARAMETER	LIMITS		UNITS	CONDITIONS
		MIN.	MAX.		
V _{OH}	Output HIGH Voltage	2.4		Volts	V _{CC} = MIN., I _{OH} = -800 μA V _{IN} = V _{IH} or V _{IL} per Truth Table
V _{OL}	Output LOW Voltage		0.4	Volts	V _{CC} = MIN., I _{OL} = 16 mA V _{IN} = V _{IH} or V _{IL} per Truth Table
V _{IH}	Input HIGH Voltage	2.0		Volts	Guaranteed Input HIGH Threshold Voltage for All Inputs
V _{IL}	Input LOW Voltage		0.8	Volts	Guaranteed Input LOW Threshold Voltage for All Inputs
V _{CD}	Input Clamp Diode Voltage		-1.5	Volts	V _{CC} = MIN., I _{IN} = -12 mA, T _A = 25°C
I _{IL}	Input LOW Current C _n P ₃ P ₂ P ₀ , P ₁ or G ₃ G ₀ or G ₂ G ₁		-1.6	mA	V _{CC} = MAX., V _{IN} = 0.4 V
			-3.2		
			-4.8		
			-6.4		
			-11.2		
			-12.8		
I _{IH}	Input HIGH Current C _n P ₃ P ₂ P ₀ , P ₁ or G ₃ G ₀ or G ₂ G ₁		40	μA	V _{CC} = MAX., V _{IN} = 2.4 V
			80		
			120		
			160		
			280		
			320		
	Input HIGH Current all inputs		1.0	mA	V _{CC} = MAX., V _{IN} = 5.5 V
I _{SC}	Output Short Circuit Current (Note 4)	-40	-100	mA	V _{CC} = MAX., V _{OUT} = 0.0 V
I _{CCH}	Power Supply Current 9342XM/54182XM 9342XC/74182XC		35	mA	V _{CC} = MAX. All outputs HIGH
			39	mA	
I _{CCL}	Power Supply Current 9342XM/54182XM 9342XC/74182XC		65	mA	V _{CC} = MAX. All Outputs LOW
			72	mA	

NOTES:

- The actual testing procedures used to guarantee the Electrical Characteristics are contained in a detailed Customer Sample Specification. A copy of this specification can be obtained from Fairchild Digital Product Marketing, Mountain View, California.
- Conditions for testing, not shown in the table, are chosen to guarantee operation under "worst case" conditions.
- The specified LIMITS represent the "worst case" value for the parameter. Since these "worst case" values normally occur at the temperature and supply voltage extremes, additional noise immunity and guard banding can be achieved by decreasing the allowable system operating ranges.
- Typical limits are at V_{CC} = 5.0 V, 25°C, and maximum loading.

SWITCHING CHARACTERISTICS ($T_A = 25^\circ\text{C}$, $V_{CC} = 5.0\text{V}$, Pin 8 = Gnd)

SYMBOL	PARAMETER	LIMITS		UNITS	CONDITIONS
		TYP.	MAX.		
t_{PLH} t_{PHL}	$(C_n \text{ to } C_{n+x}, C_{n+y}, C_{n+z})$	12 15	16 19	ns	$\bar{P}_0 = \bar{P}_1 = \bar{P}_2 = \text{Gnd}$, $\bar{G}_0 = \bar{G}_1 = \bar{G}_2 = 4.5\text{V}$ Fig.1
t_{PLH} t_{PHL}	$(\bar{P}_0, \bar{P}_1, \text{ or } \bar{P}_2 \text{ to } C_{n+x}, C_{n+y}, \text{ or } C_{n+z})$	8 9	10 11	ns	$\bar{P}_x = \text{Gnd}$ (If not under test), $C_n = \bar{G}_0 = \bar{G}_1 = \bar{G}_2 = 4.5\text{V}$, Fig.2
t_{PLH} t_{PHL}	$(\bar{G}_0, \bar{G}_1 \text{ or } \bar{G}_2 \text{ to } C_{n+x}, C_{n+y}, \text{ or } C_{n+z})$	8 9	10 11	ns	$\bar{G}_x = 4.5\text{V}$ (If not under test), $C_n = \bar{P}_0 = \bar{P}_1 = \bar{P}_2 = \text{Gnd}$, Fig.2
t_{PLH} t_{PHL}	$(\bar{P}_1, \bar{P}_2 \text{ or } \bar{P}_3 \text{ to } \bar{G} \text{ or } \bar{P})$	12 15	16 19	ns	$\bar{P}_x = \text{Gnd}$ (If not under test), $\bar{G}_0 = \bar{G}_1 = \bar{G}_2 = \bar{G}_3 = C_n = 4.5\text{V}$ Fig.1
t_{PLH} t_{PHL}	$(\bar{G}_0, \bar{G}_1, \bar{G}_2 \text{ or } \bar{G}_3 \text{ to } \bar{G})$	12 15	16 19	ns	$\bar{G}_x = 4.5\text{V}$ (If not under test), $\bar{P}_1 = \bar{P}_2 = \bar{P}_3 = \text{Gnd}$, Fig. 1
t_{PLH} t_{PHL}	$(\bar{P}_0, \bar{P}_1, \bar{P}_2 \text{ or } \bar{P}_3 \text{ to } \bar{P})$	12 15	16 19	ns	$\bar{P}_x = \text{Gnd}$ (If not under test), Fig. 1

SWITCHING TIME WAVEFORMS

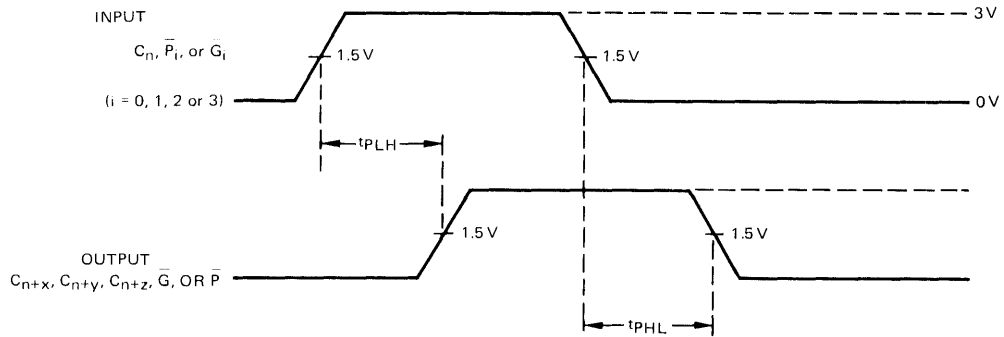

Fig. 1

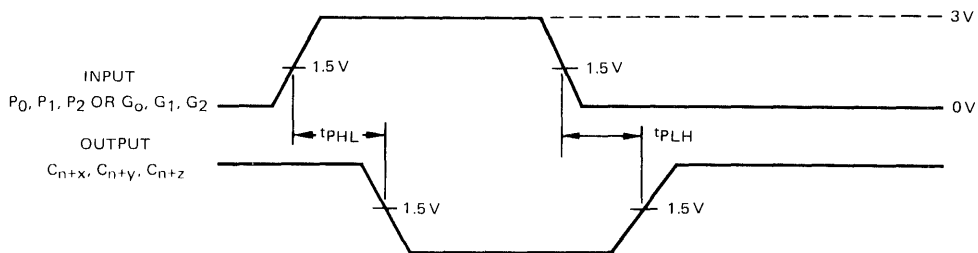

Fig. 2

TTL/MSI 93S42

LOOKAHEAD CARRY GENERATOR

DESCRIPTION — The TTL/MSI 93S42 is a high speed Lookahead Carry Generator. It is generally used with the 93S41 4-Bit Arithmetic Logic Unit to provide super high speed lookahead over word lengths of more than four bits. The lookahead carry generator is fully compatible with all members of the Fairchild TTL Family.

- **TYPICALLY 4 ns DELAY FOR EACH LEVEL OF LOOKAHEAD**
- **PROVIDES LOOKAHEAD CARRIES ACROSS A GROUP OF FOUR ALU'S**
- **MULTI-LEVEL LOOKAHEAD FOR HIGH SPEED ARITHMETIC OPERATION OVER LONG WORD LENGTHS**
- **INPUT CLAMP DIODES**
- **TTL COMPATIBLE**

PIN NAMES

C_n	Carry Input
\bar{G}_0, \bar{G}_2	Carry Generate (Active Low) Inputs
\bar{G}_1	Carry Generate (Active Low) Input
\bar{G}_3	Carry Generate (Active Low) Input
\bar{P}_0, \bar{P}_1	Carry Propagate (Active Low) Inputs
\bar{P}_2	Carry Propagate (Active Low) Input
\bar{P}_3	Carry Propagate (Active Low) Input
$C_{n+x}, C_{n+y}, C_{n+z}$	Carry Outputs
\bar{G}	Carry Generate (Active Low) Output
\bar{P}	Carry Propagate (Active Low) Output

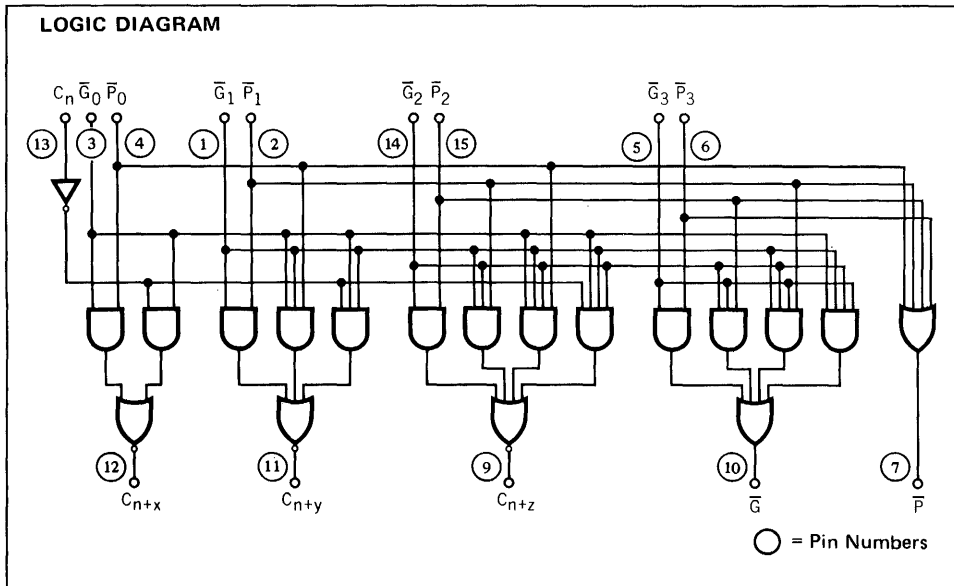

LOGIC SYMBOL

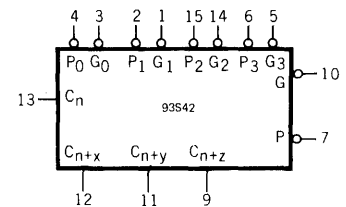

V_{CC} = Pin 16
GND = Pin 8

CONNECTION DIAGRAMS DIP (TOP VIEW)

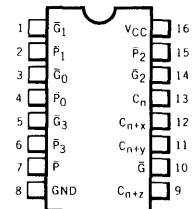

FLATPAK (TOP VIEW)

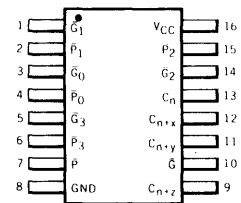

TTL/MSI 9344

BINARY (4-BIT BY 2-BIT) FULL MULTIPLIER

DESCRIPTION — The TTL/MSI 9344 is a 4-bit by 2-bit Full Multiplier building block. It multiplies two binary numbers and simultaneously adds two other binary numbers to the product. 9344's can be interconnected to form a high speed multiplier array of any size. The device is constructed with TTL compatible inputs and outputs. Inputs are buffered to reduce loading. The device is fully compatible with all members of the Fairchild TTL family.

- PERFORMS DIRECT MULTIPLICATION
- EXPANDS TO ANY SIZE ARRAY WITHOUT ADDITIONAL COMPONENTS
- MULTIPLIES AND ADDS SIMULTANEOUSLY
- TTL COMPATIBLE

PIN NAMES

$\overline{X}_0, \overline{X}_1, \overline{X}_2, \overline{X}_3$	Multiplicand Inputs (Active LOW)
$\overline{Y}_0, \overline{Y}_1$	Multiplier Inputs (Active LOW)
\overline{M}_1	Additive
$\overline{K}_0, \overline{M}_0$	Carry Inputs
$\overline{K}_1, \overline{K}_2, \overline{K}_3$	(Active LOW)
$\overline{S}_0, \overline{S}_1, \overline{S}_2, \overline{S}_3, \overline{S}_4, \overline{S}_5$	Outputs

LOADING

$\overline{X}_0, \overline{X}_1, \overline{X}_2, \overline{X}_3$	2/3 U.L.
$\overline{Y}_0, \overline{Y}_1$	2/3 U.L.
\overline{M}_1	1.0 U.L.
$\overline{K}_0, \overline{M}_0$	4.0 U.L.
$\overline{K}_1, \overline{K}_2, \overline{K}_3$	2.0 U.L.
$\overline{S}_0, \overline{S}_1, \overline{S}_2, \overline{S}_3, \overline{S}_4, \overline{S}_5$	10 U.L.

1 Unit Load (U.L.) = 40 μ A HIGH/1.6 mA LOW.

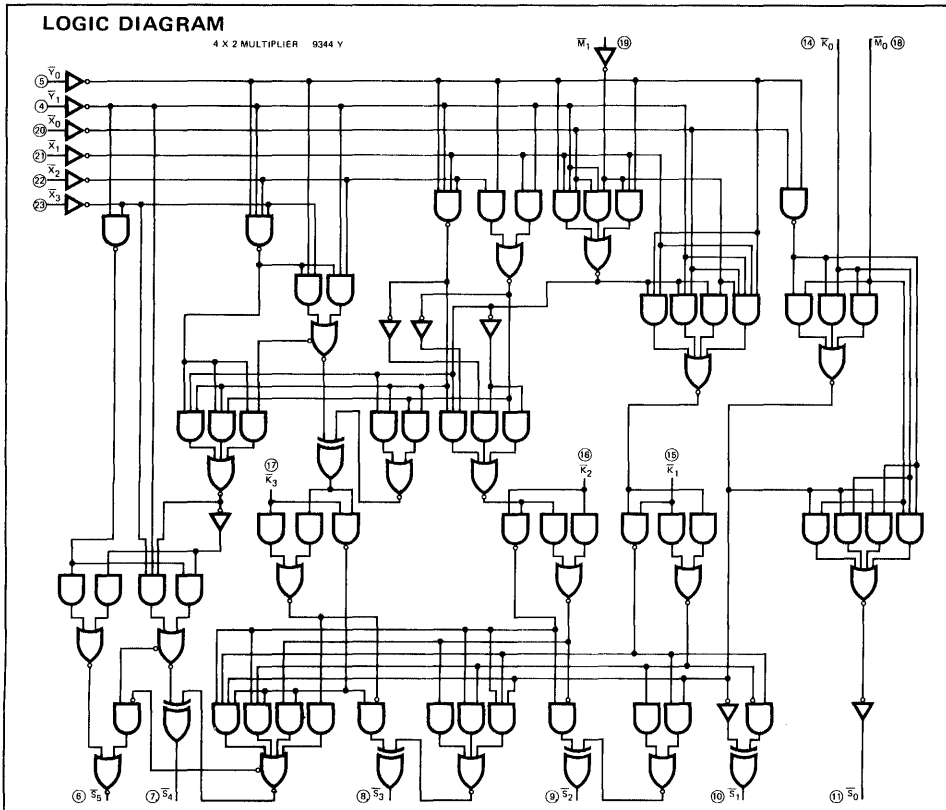

LOGIC SYMBOL

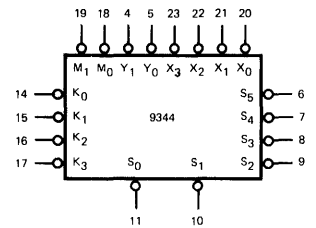

VCC = PIN 24
GND = PIN 12
NC = PIN 1, 2, 3, 13

**CONNECTION DIAGRAMS
DIP (TOP VIEW)**

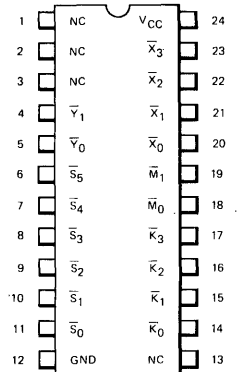

FLATPAK (TOP VIEW)

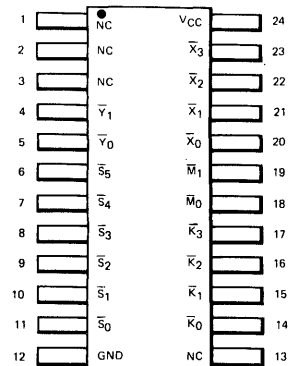

FUNCTIONAL DESCRIPTION — The 9344 is a binary full multiplier for 4-bit by 2-bit words. It is easily expandable in an array to form a high speed parallel multiplier of any length.

The functional equation is illustrated below:

$$S(6\text{-bits}) = \bar{X}(4\text{-bits}) \text{ times } \bar{Y}(2\text{-bits}) \text{ plus } \bar{M}(2\text{-bits}) \text{ plus } \bar{K}(4\text{-bits})$$

Functionally the 9344 multiplies a 4-bit word ($\bar{X}_0 - \bar{X}_3$) by a two bit word ($\bar{Y}_0 - \bar{Y}_1$), generating eight partial products. Two other words, $\bar{K}_0 - \bar{K}_3$ and $\bar{M}_0 - \bar{M}_1$, are added to these partial products through a lookahead carry adder, generating a 6-bit product/sum.

The function can be described by the following equation (note that "+" means arithmetic addition) :

$$S = 2^0 (\bar{X}_0 \bar{Y}_0 + \bar{M}_0 + \bar{K}_0) + 2^1 (\bar{X}_1 \bar{Y}_0 + \bar{X}_0 \bar{Y}_1 + \bar{M}_1 + \bar{K}_1) + 2^2 (\bar{X}_2 \bar{Y}_0 + \bar{X}_1 \bar{Y}_1 + \bar{K}_2) + 2^3 (\bar{X}_3 \bar{Y}_0 + \bar{X}_2 \bar{Y}_1 + \bar{K}_3) + 2^4 (\bar{X}_3 \bar{Y}_1)$$

All inputs and outputs are active LOW; X and Y inputs are buffered to present only one TTL unit load.

The device operates only on positive numbers. If two's complement multiplication is required, then the numbers must be changed to sign-magnitude before multiplication, or else the product must be corrected following multiplication of the two's complement numbers. The correction algorithm depends on whether X or Y or both are negative.

- If X is negative:
Subtract Y from most significant half of product.
- If Y is negative:
Subtract X from most significant half of product.
- If both X and Y are negative:
Add X plus Y to most significant half of product.

The result will be the correct two's complement product.

MULTIPLICATION TIME

NUMBER OF BITS	PACKAGES	TIME (ns)
8 x 8	8	150
12 x 12	18	260
16 x 16	32	350
24 x 24	72	550

Fig. 1

WEIGHTING FACTORS OF THE BASIC MULTIPLIER

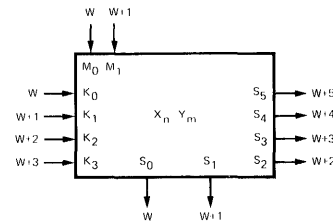

This block represents the basic 4 by 2-bit multiplier, and indicates the weighting factors (power of two) attached to each of the inputs and outputs.

Fig. 2

SWITCHING CHARACTERISTICS

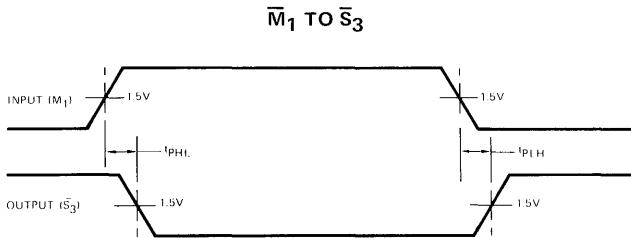

Fig. 3

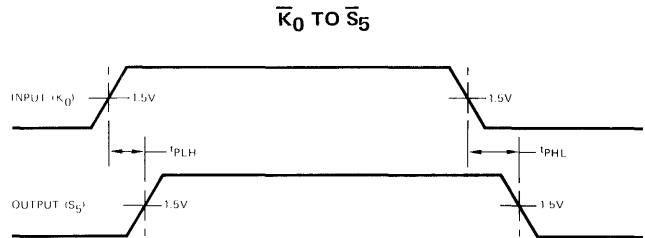

Fig. 4

ABSOLUTE MAXIMUM RATINGS (above which the useful life may be impaired)

Storage Temperature	-65°C to +150°C
Temperature (Ambient) Under Bias	-55°C to +125°C
V _{CC} Pin Potential to Ground Pin	-0.5 V to +7.0 V
*Input Voltage (dc)	-0.5 V to +5.5 V
*Input Current (dc)	-30 mA to +5.0 mA
Voltage Applied to Outputs (Output HIGH)	-0.5 V to +V _{CC} value
Output Current (dc) (Output LOW)	+30 mA

*Either Input Voltage limit or Input Current limit is sufficient to protect the inputs.

GUARANTEED OPERATING RANGES

PART NUMBER	SUPPLY VOLTAGE (V _{CC})			TEMPERATURE
	MIN.	TYP.	MAX.	
9344 XM	4.5 V	5.0 V	5.5 V	-55°C to 125°C
9344 XC	4.75 V	5.0 V	5.25 V	0°C to 75°C

X = package type; F for Flatpak, D for Ceramic Dip, P for Plastic Dip. See Packaging Information Section for packages available on this product.

ELECTRICAL CHARACTERISTICS OVER OPERATING TEMPERATURE RANGE (unless otherwise noted)

SYMBOL	PARAMETER	LIMITS			UNITS	CONDITIONS
		MIN.	TYP. (Note 4)	MAX.		
V _{IH}	Input HIGH Voltage	2.0			Volts	Guaranteed Input HIGH Threshold Voltage for All Inputs
V _{IL}	Input LOW Voltage			0.8	Volts	Guaranteed Input LOW Threshold Voltage for All Inputs
V _{OH}	Output HIGH Voltage	2.4			Volts	V _{CC} = MIN., I _{OH} = -800 μA, V _{IN} = V _{IH} or V _{IL}
V _{OL}	Output LOW Voltage			0.4	Volts	V _{CC} = MIN., I _{OL} = 16 mA, V _{IN} = V _{IH} or V _{IL}
I _{IH}	Input HIGH Current Y _{0,1} ; X _{0,1,2,3} M ₁ K _{1,2,3} K ₀ , M ₀			27 40 80 160	μA	V _{CC} = MAX., V _{IN} = 2.4 V
I _{IL}	Input LOW Current Y _{0,1} ; X _{0,1,2,3} M ₁ K _{1,2,3} K ₀ , M ₀			-1.07 -1.6 -3.2 -6.4	mA	V _{CC} = MAX., V _{IN} = 0.4 V
I _{SC}	Output Short Circuit Current (Note 5)	-20		-70	mA	V _{CC} = MAX., V _{OUT} = 0.0 V
I _{CC}	Power Supply Current		110	150	mA	V _{CC} = MAX.
V _{CD}	Input Clamp Diode Voltage			-1.5	Volts	V _{CC} = MIN., I _{IN} = -12 mA, T _A = 25°C

NOTES:

1. The actual testing procedures used to guarantee the Electrical Characteristics are contained in a detailed Customer Sample Specification. A copy of this specification can be obtained from Fairchild Digital Product Marketing, Mountain View, California.
2. Conditions for testing, not shown in the table, are chosen to guarantee operation under "worst case" conditions.
3. The specified LIMITS represent the "worst case" value for the parameter. Since these "worst case" values normally occur at the temperature and supply voltage extremes, additional noise immunity and guard banding can be achieved by decreasing the allowable system operating ranges.
4. Typical limits are at V_{CC} = 5.0 V, 25°C, and maximum loading.
5. Not more than one output should be shorted at a time.

SWITCHING CHARACTERISTICS (T_A = 25°C)

SYMBOL	PARAMETER	LIMITS			UNITS	CONDITIONS
		MIN.	TYP.	MAX.		
t _{PLH}	Turn Off Delay Input to Output (M ₁ to S ₃)		40	51	ns	V _{CC} = 5.0 V C _L = 15 pF
t _{PHL}	Turn On Delay Input to Output (M ₁ to S ₃)		40	52	ns	
t _{PLH}	Turn Off Delay Input to Output (K ₀ to S ₅)		16	22	ns	
t _{PHL}	Turn On Delay Input to Output (K ₀ to S ₅)		30	39	ns	

TYPICAL MULTIPLICATION ARRAYS

The 9344 can be assembled in an iterative structure to perform multi-bit multiplication. The blocks are interconnected so that partial product sums generated in a particular 9344 are applied, if necessary, to equal weight carry inputs ($\overline{K}_{0,1,2,3}$ or $\overline{M}_{0,1}$) of succeeding stages.

In the iterative multiplication arrays shown, weighting factors of the carry and sums between 9344's are indicated (i.e., $0 = 2^0$, $1 = 2^1$, $2 = 2^2$, etc.). Labels inside the blocks identify bits multiplied in that block. For instance 0-0 refers to multiplicand bits $B_0, 1, 2, 3$ and multiplier bits $A_0, 1$, while 4-2 would represent multiplicand bits $B_4, 5, 6, 7$ and multiplier bits $A_2, 3$.

8-BIT BY 5-BIT MULTIPLICATION ARRAY

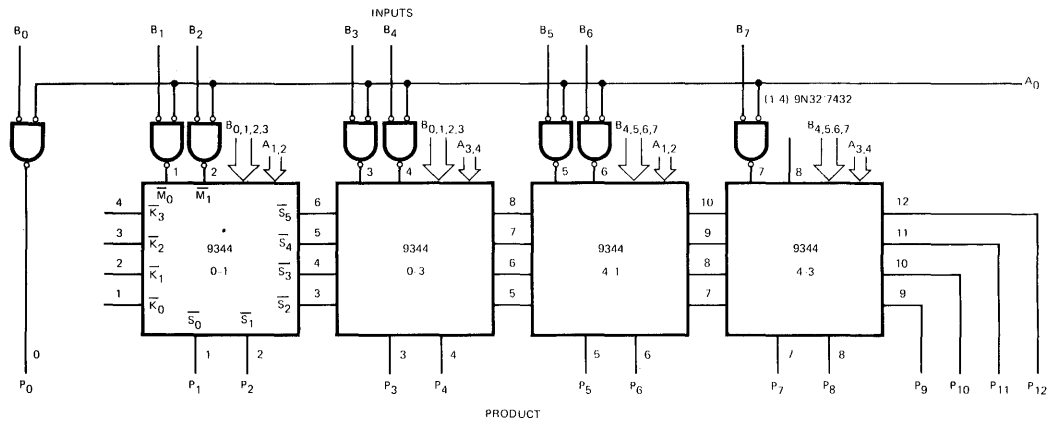

Fig. 5

8-BIT BY 8-BIT MULTIPLICATION ARRAY

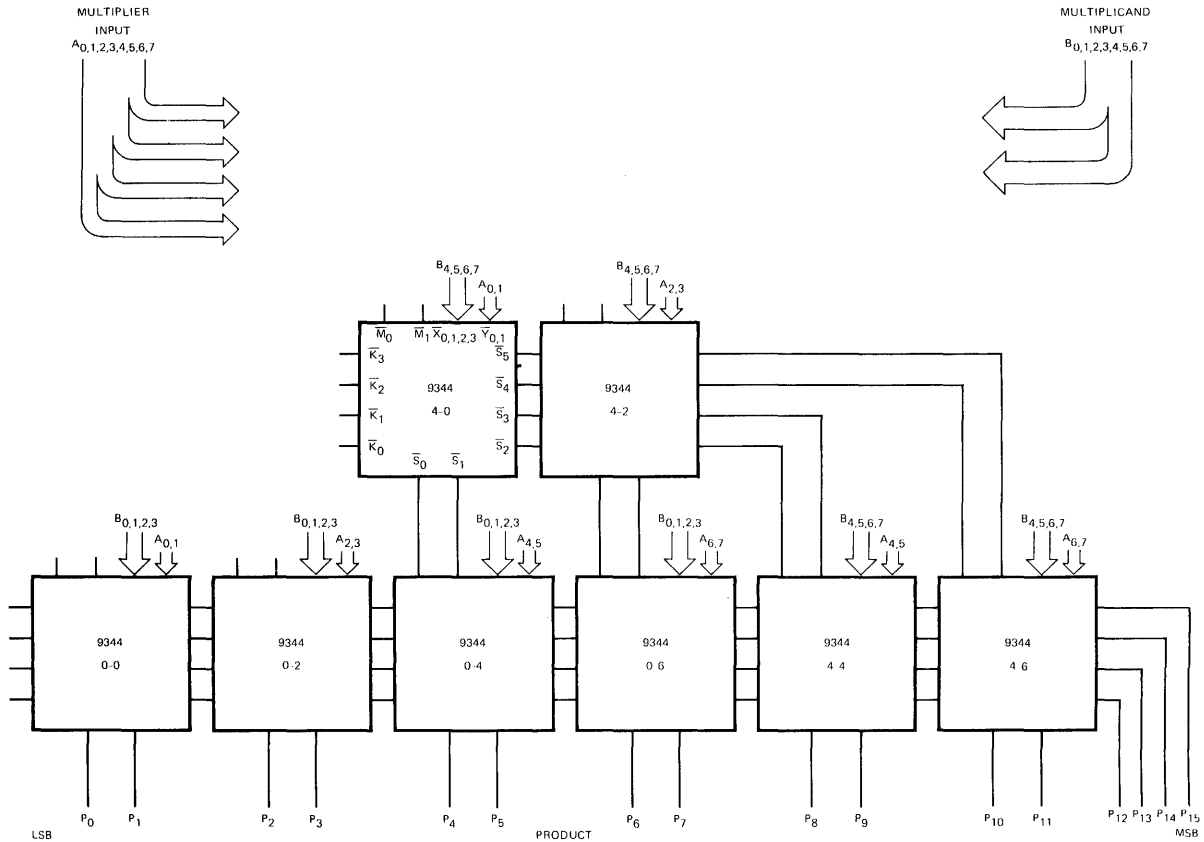
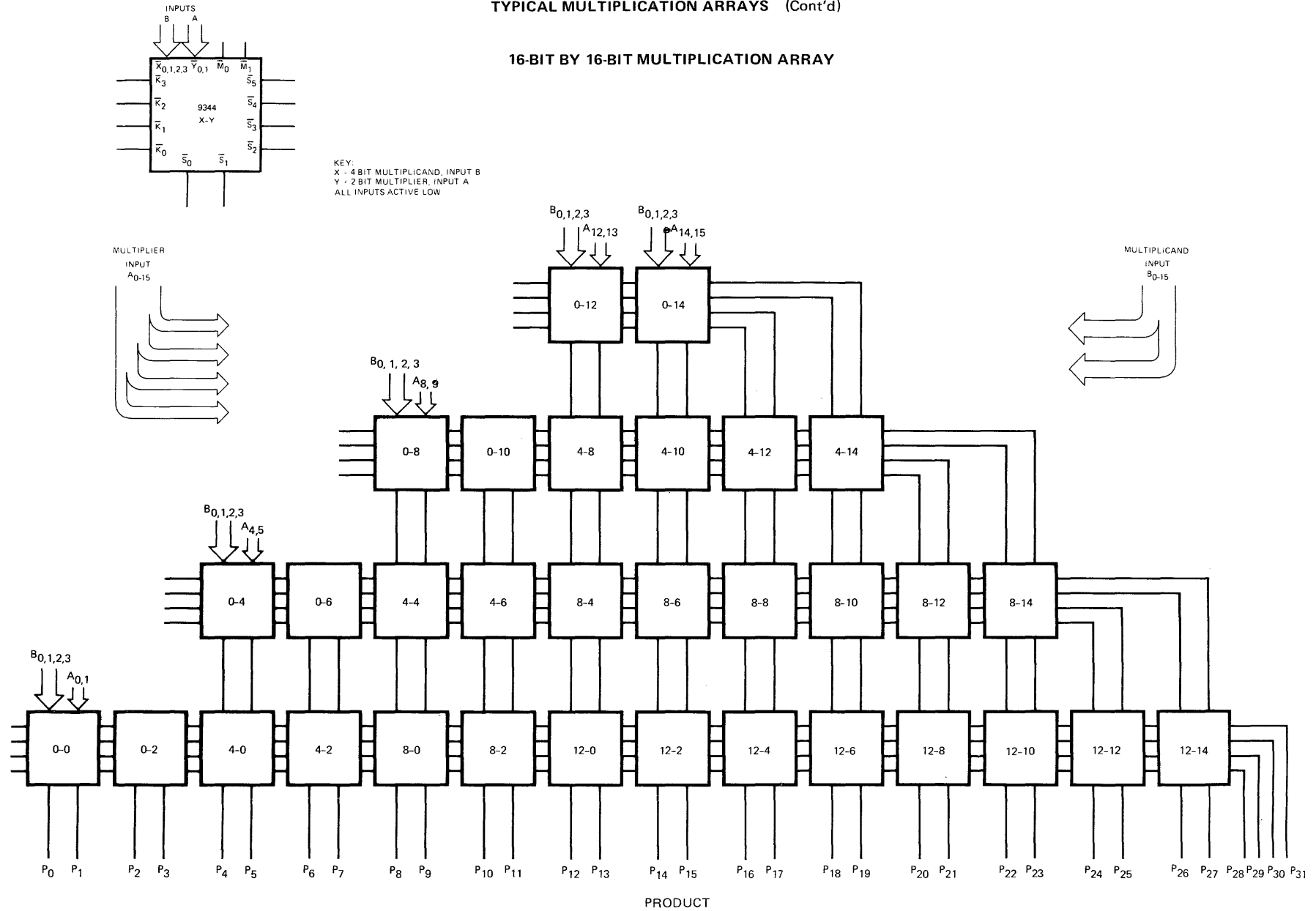

Fig. 6

TYPICAL MULTIPLICATION ARRAYS (Cont'd)

16-BIT BY 16-BIT MULTIPLICATION ARRAY



Note: Each block represents one 9344. Labels inside the blocks identify bits multiplied in that block. The first number is the 4-bit B input, and the second number is the 2-bit A input. For instance, 12-0 refers to multiplicand bits B₁₂, 13, 14, 15 and multiplier bits A₀, 1.

Fig. 7

TTL/MSI 9345/5445, 7445 93145/54145, 74145 1-OF-10 DECODER/DRIVER

DESCRIPTION — The 9345/5445, 7445 and 93145/54145, 74145 1-of-10 Decoder/Drivers are designed to accept BCD inputs and provide appropriate outputs to drive 10 digit incandescent displays. All outputs remain off for all invalid binary input conditions. These devices are designed for use as indicator/relay drivers or as open-collector logic circuit drivers. Each of the high breakdown output transistors (9345/5445, 7445 = 30 V and 93145/54145, 74145 = 15 V) will sink up to 80 mA of current. Typical power dissipation is 215 mW.

PIN NAMES

P_A, P_B, P_C, P_D
 \bar{Q}_0 to \bar{Q}_9

BCD Inputs
Outputs

LOADING
(Note a)
1 U.L.
(Note b)

NOTES:

- a. 1 U.L. = 40 μ A HIGH/1.6 mA LOW.
- b. **Output Characteristics.**
MAX. Sinking current in LOW state 80 mA.
MIN. HIGH Voltage breakdown:
9345/5445, 7445 30 V
93145/54145, 74145 15 V

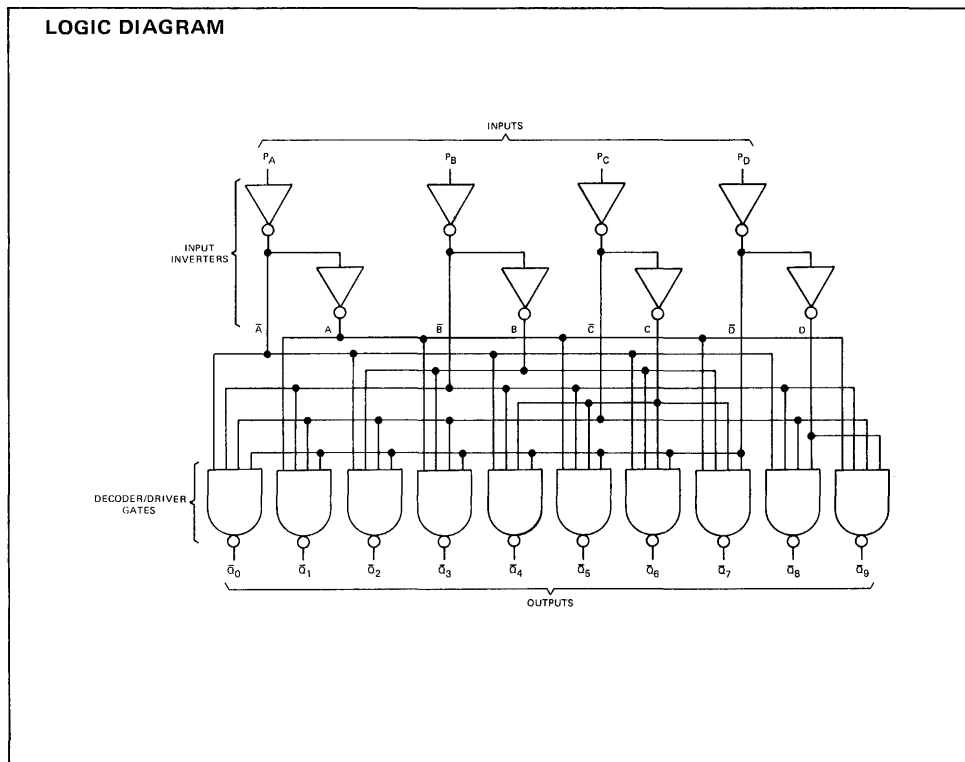
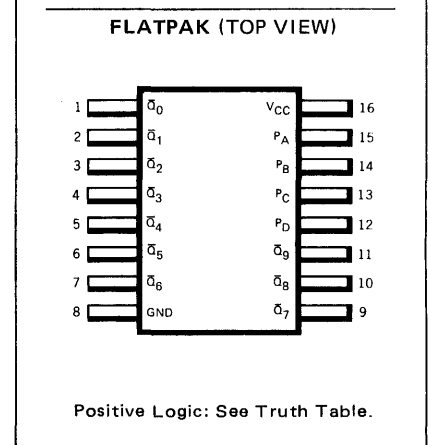
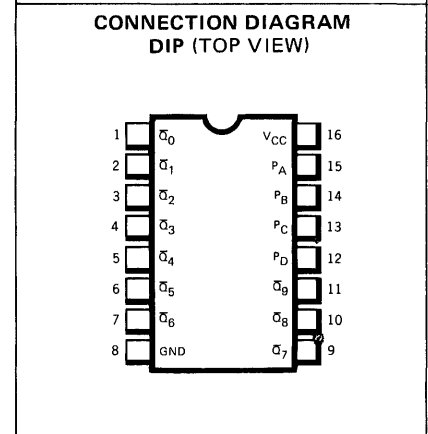
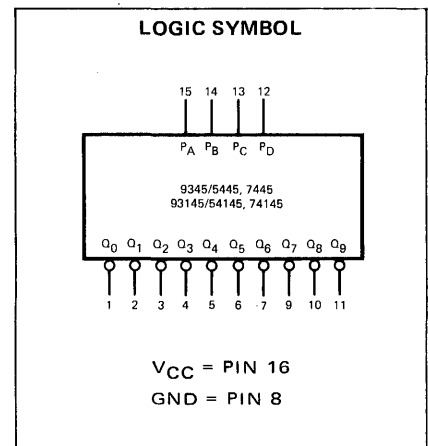

8

TTL/MSI • 9345/5445, 7445 • 93145/54145, 74145

ABSOLUTE MAXIMUM RATINGS (above which the useful life may be impaired)

Storage Temperature	-65°C to +150°C
Temperature (Ambient) Under Bias	-55°C to +125°C
V _{CC} Pin Potential to Ground Pin	-0.5 V to +7.0 V
*Input Voltage (dc)	-0.5 V to +5.5 V
*Input Current (dc)	-30 mA to +5.0 mA
Voltage Applied to Outputs (Output HIGH)	-0.5V to +30V
Output Current (dc) (Output LOW)	+80 mA

*Either Input Voltage limit or Input Current limit is sufficient to protect the inputs.

RECOMMENDED OPERATING CONDITIONS

PARAMETER	9345XM/5445XM 93145XM/54145XM			9345XC/7445XC 93145XC/74145XC			UNITS
	MIN.	TYP.	MAX.	MIN.	TYP.	MAX.	
Supply Voltage V _{CC} (See Note 3)	4.5	5.0	5.5	4.75	5.0	5.25	Volts
Operating Free-Air Temperature Range	-55	25	125	0	25	70	°C
PARAMETER	9345/5445, 7445			93145/54145, 74145			UNITS
	MIN.	TYP.	MAX.	MIN.	TYP.	MAX.	
Voltage on Any Output (See Note 4)			30			15	Volts

X = package type; F for Flatpak, D for Ceramic Dip, P for Plastic Dip. See Packaging Information Section for packages available on this product.

ELECTRICAL CHARACTERISTICS OVER OPERATING TEMPERATURE RANGE (Unless Otherwise Noted)

SYMBOL	PARAMETER	LIMITS			UNITS	TEST CONDITIONS (Note 1)	TEST FIGURE
		MIN.	TYP. (Note 2)	MAX.			
V _{IH}	Input HIGH Voltage	2.0			Volts	Guaranteed Input HIGH Threshold Voltage	1 & 2
V _{IL}	Input LOW Voltage			0.8	Volts	Guaranteed Input LOW Threshold Voltage	1 & 2
V _{OL}	Output LOW Voltage		0.5	0.9	Volts	I _{OL} = 80 mA I _{OL} = 20 mA	V _{CC} = MIN.
				0.4	Volts		
V _{OH}	Output HIGH Voltage	30			Volts	9345/5445, 7445	V _{CC} = MAX. I _{OH} = 250 μA
		15			Volts	93145/54145, 74145	
I _{IH}	Input HIGH Current (Each Input)			40	μA	V _{CC} = MAX., V _{IN} = 2.4 V	3
				1.0	mA	V _{CC} = MAX., V _{IN} = 5.5 V	
I _{IL}	Input LOW Current (Each Input)			-1.6	mA	V _{CC} = MAX., V _{IN} = 0.4 V	4
I _{CC}	Supply Current		43	62	mA	9345/5445, 93145/54145	V _{CC} = MAX.
			43	70	mA	9345/7445, 93145/74145	

SWITCHING CHARACTERISTICS (T_A = 25°C)

SYMBOL	PARAMETER	LIMITS			UNITS	TEST CONDITIONS	TEST FIGURE
		MIN.	TYP.	MAX.			
t _{PLH}	Turn Off Delay Input to Output			50	ns	V _{CC} = 5.0 V C _L = 5 pF R _L = 100Ω	A
t _{PHL}	Turn On Delay Input to Output			50	ns		

NOTES:

- For conditions shown as MIN. or MAX., use the appropriate value specified under recommended operating conditions for the applicable device type.
- Typical limits are at V_{CC} = 5.0 V, 25°C.
- These voltage values are with respect to network ground terminal
- This rating applies when the output is off.

TRUTH TABLE

INPUTS				OUTPUTS									
P _D	P _C	P _B	P _A	\bar{Q}_0	\bar{Q}_1	\bar{Q}_2	\bar{Q}_3	\bar{Q}_4	\bar{Q}_5	\bar{Q}_6	\bar{Q}_7	\bar{Q}_8	\bar{Q}_9
L	L	L	L	L	H	H	H	H	H	H	H	H	H
L	L	L	H	H	L	H	H	H	H	H	H	H	H
L	L	H	L	H	H	L	H	H	H	H	H	H	H
L	L	H	H	H	H	H	L	H	H	H	H	H	H
L	H	L	L	H	H	H	H	H	L	H	H	H	H
L	H	L	H	H	H	H	H	H	H	L	H	H	H
L	H	H	L	H	H	H	H	H	H	H	L	H	H
L	H	H	H	H	H	H	H	H	H	H	H	L	H
H	L	L	L	H	H	H	H	H	H	H	H	L	H
H	L	L	H	H	H	H	H	H	H	H	H	H	L
H	L	H	L	H	H	H	H	H	H	H	H	H	H
H	L	H	H	H	H	H	H	H	H	H	H	H	H
H	H	L	L	H	H	H	H	H	H	H	H	H	H
H	H	L	H	H	H	H	H	H	H	H	H	H	H
H	H	H	L	H	H	H	H	H	H	H	H	H	H
H	H	H	H	H	H	H	H	H	H	H	H	H	H

H = HIGH Voltage Level
L = LOW Voltage Level

SCHEMATIC DIAGRAMS

EACH PAIR OF INPUT INVERTERS

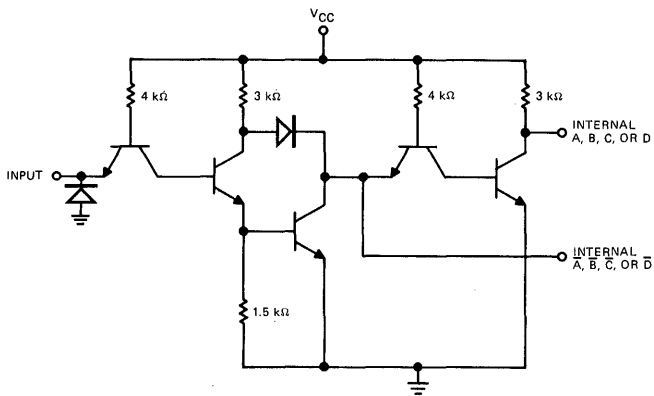

EACH DECODER/DRIVER GATE

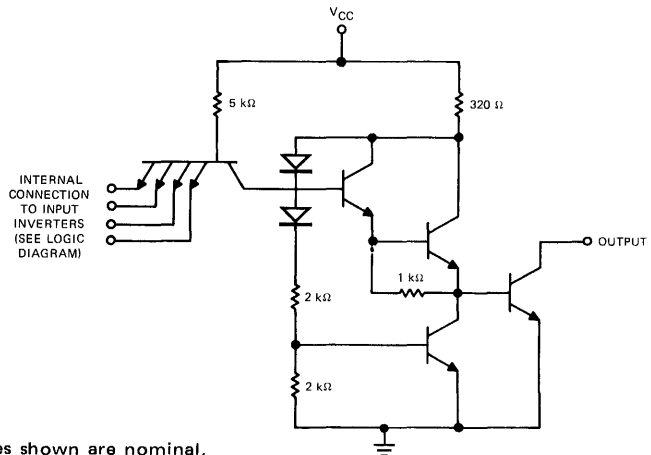

NOTE: Component values shown are nominal.

PARAMETER MEASUREMENT INFORMATION

DC TEST CIRCUITS*

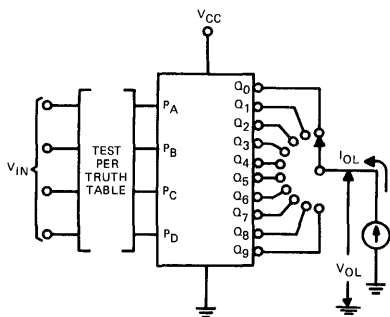

1. Each output is tested separately in the ON state.

Fig. 1

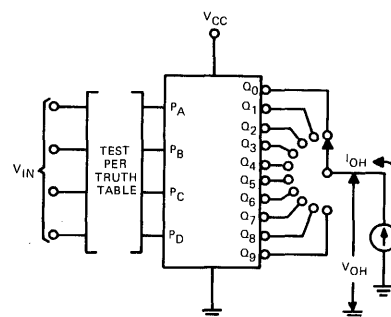

1. Each output is tested separately in the OFF state.

Fig. 2

*Arrows indicate actual direction of current flow.

PARAMETER MEASUREMENT INFORMATION

D.C. TEST CIRCUITS* (Continued)

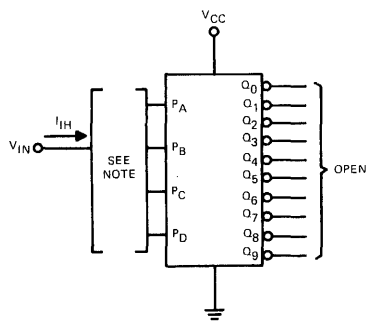

1. Each input is tested separately.

Fig. 3

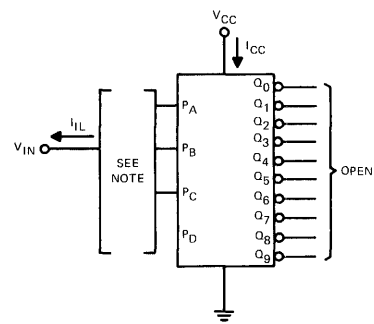

1. When testing I_{IL} each input is tested separately.
2. When testing I_{CC} all inputs are grounded and outputs are open.

Fig. 4

* Arrows indicate actual direction of current flow.

PARAMETER MEASUREMENT INFORMATION

SWITCHING CHARACTERISTICS

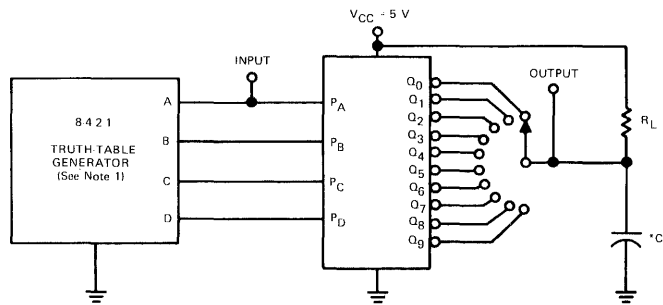

* Includes probe and jig capacitance.

TEST CIRCUIT

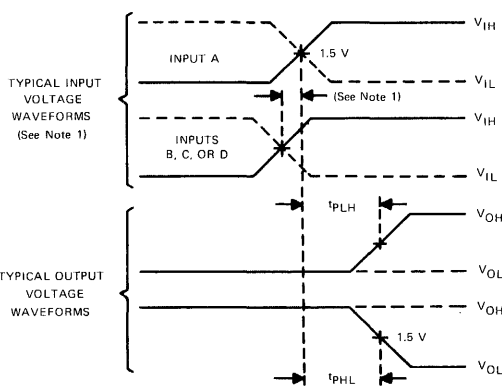

VOLTAGE WAVEFORMS

NOTE:

1. The truth-table generator has the following characteristics:
 $V_{OH} \geq 2.4 V$, $V_{OL} \leq 0.4 V$, t_r and $t_f < 10 ns$, and $PRR = 1 MHz$. Inputs B, C, and D transitions occur simultaneously with or prior to input A transitions.

Fig. A SWITCHING TIMES

TTL/MSI 9348

12-INPUT PARITY CHECKER/GENERATOR

DESCRIPTION — The TTL/MSI 9348 is a 12-Input Parity Checker/Generator generating odd and even parity outputs. It can be used in high speed error detection applications. The 9348 uses TTL technology for high capacitive drive capability, and provides low impedance in both logic states for good ac noise immunity. All inputs feature diode clamping to reduce negative line transients. This device is compatible with all members of the TTL family of digital integrated circuits.

- BOTH ODD AND EVEN PARITY OUTPUTS PROVIDED
- GENERATES A PARITY BIT FOR UP TO 12 BITS
- CHECKS FOR PARITY ON UP TO 12 BITS
- EASILY EXPANDABLE
- HIGH DRIVE OUTPUT CIRCUITRY
- INPUT CLAMP DIODE LIMITS HIGH SPEED TERMINATION EFFECTS
- TTL COMPATIBLE

PIN NAMES

I_0 to I_{11}	Parity Inputs
PO	Odd Parity Output (Note b)
PE	Even Parity Output (Note b)

LOADING

(Note a)
 2 U.L.
 10 U.L.
 10 U.L.

NOTES:

- (a) 1 Unit Load (U.L.) = 40 μ A HIGH/1.6 mA LOW.
 (b) 10 U.L. is the output LOW drive factor and 20 U.L. is the output HIGH drive factor.

LOGIC DIAGRAM

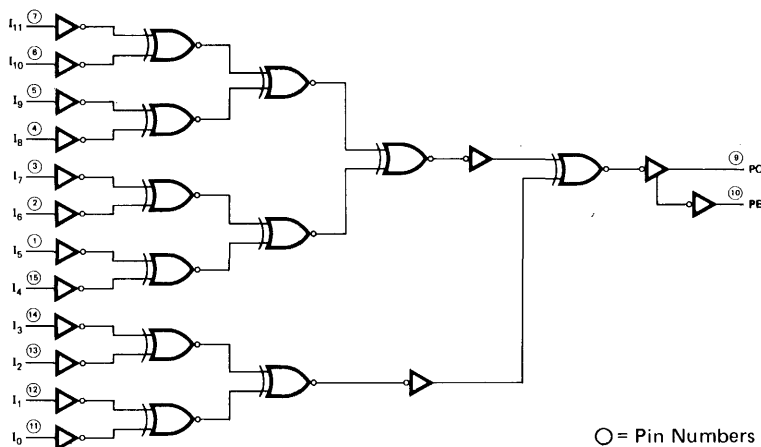

LOGIC SYMBOL

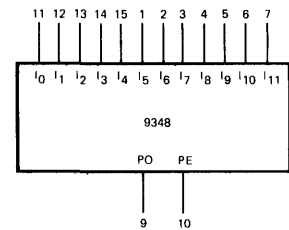

V_{CC} = Pin 16
 Gnd = Pin 8

CONNECTION DIAGRAMS

DIP (TOP VIEW)

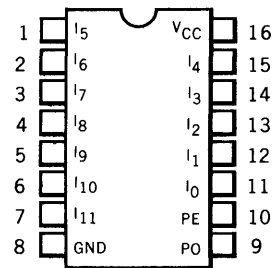

FLATPAK (TOP VIEW)

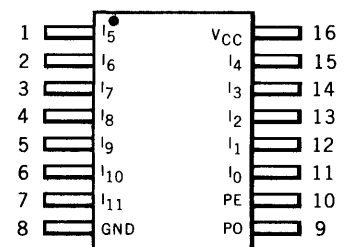

FUNCTIONAL DESCRIPTION – The MSI 9348 is a 12-input parity generator. It provides odd and even parity for up to 12 data bits. The Even Parity output (PE) will be HIGH if an even number of logic ones are present on the inputs. The Odd Parity output (PO) will be HIGH if an odd number of logic ones are present on the inputs. The logic equations for the outputs are shown below.

$$PO = I_0 \oplus I_1 \oplus I_2 \oplus I_3 \oplus I_4 \oplus I_5 \oplus I_6 \oplus I_7 \oplus I_8 \oplus I_9 \oplus I_{10} \oplus I_{11}$$

$$PE = I_0 \oplus I_1 \oplus I_2 \oplus I_3 \oplus I_4 \oplus I_5 \oplus I_6 \oplus I_7 \oplus I_8 \oplus I_9 \oplus I_{10} \oplus I_{11}$$

NOTE: Less through delay is encountered from the I₀, I₁, I₂, and I₃ inputs than I₄ thru I₁₁ inputs. Therefore, if some signals are slower than others, the slower signals should be applied to these four inputs for maximum speed.

TRUTH TABLE

INPUTS		OUTPUTS	
I ₀ , I ₁ , I ₂ , I ₃ , I ₄ , I ₅ , I ₆ , I ₇ , I ₈ , I ₉ , I ₁₀ , I ₁₁		P _O	P _E
All Twelve	Inputs LOW	0	1
Any One	Input HIGH	1	0
Any Two	Inputs HIGH	0	1
Any Three	Inputs HIGH	1	0
Any Four	Inputs HIGH	0	1
Any Five	Inputs HIGH	1	0
Any Six	Inputs HIGH	0	1
Any Seven	Inputs HIGH	1	0
Any Eight	Inputs HIGH	0	1
Any Nine	Inputs HIGH	1	0
Any Ten	Inputs HIGH	0	1
Any Eleven	Inputs HIGH	1	0
All Twelve	Inputs HIGH	0	1

TYPICAL INPUT AND OUTPUT CHARACTERISTICS

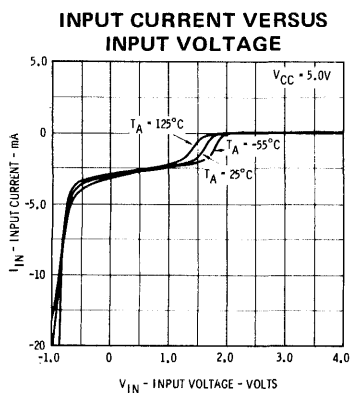
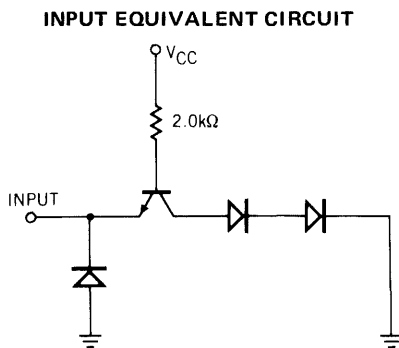

Fig. 1

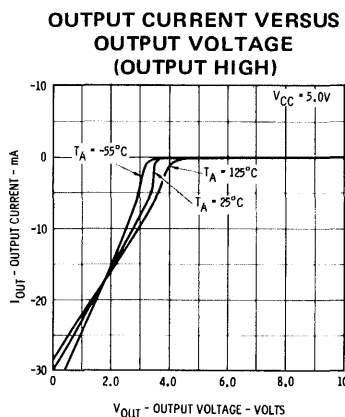
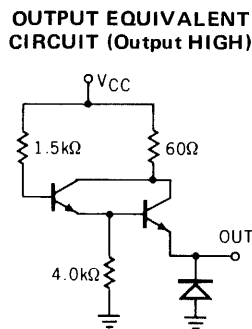

Fig. 2

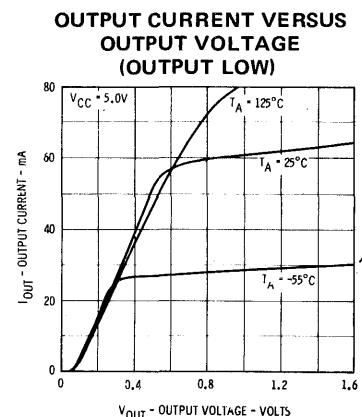
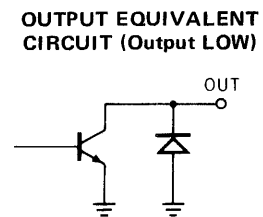

Fig. 3

ABSOLUTE MAXIMUM RATINGS (above which the useful life may be impaired)

- Storage Temperature -65°C to +150°C
- Temperature (Ambient) Under Bias -55°C to +125°C
- V_{CC} Pin Potential to Ground Pin -0.5 V to +7.0 V
- *Input Voltage (dc) -0.5 V to +5.5 V
- *Input Current (dc) -30 mA to +5.0 mA
- Voltage Applied to Outputs (Output HIGH) -0.5 V to +V_{CC} value
- Output Current (dc) (Output LOW) +30 mA

*Either Input Voltage Limit or Input Current is sufficient to protect the inputs.

FAIRCHILD TTL/MSI • 9348

GUARANTEED OPERATING RANGES

PART NUMBER	SUPPLY VOLTAGE (V _{CC})			TEMPERATURE
	MIN.	TYP.	MAX.	
9348XM	4.5 V	5.0 V	5.5 V	-55°C to 125°C
9348XC	4.75 V	5.0 V	5.25 V	0°C to 75°C

X = package type; F for Flatpak, D for Ceramic Dip, P for Plastic Dip. See Packaging Information Section for packages available on this product.

ELECTRICAL CHARACTERISTICS OVER OPERATING TEMPERATURE RANGE (unless otherwise noted)

SYMBOL	PARAMETER	LIMITS			UNITS	CONDITIONS
		MIN.	TYP. (Note 4)	MAX.		
V _{IH}	Input HIGH Voltage	2.0			Volts	Guaranteed Input HIGH Threshold Voltage for All Inputs
V _{IL}	Input LOW Voltage			0.8	Volts	Guaranteed Input LOW Threshold Voltage for All Inputs
V _{OH}	Output HIGH Voltage	2.4			Volts	V _{CC} = MIN., I _{OH} = -800 μA V _{IN} = V _{IH} or V _{IL} per Truth Table
V _{OL}	Output LOW Voltage			0.4	Volts	V _{CC} = MIN., I _{OL} = 16 mA V _{IN} = V _{IH} or V _{IL} per Truth Table
I _{IH}	Input HIGH Current		20	80	μA	V _{CC} = MAX., V _{IN} = 2.4 V
I _{IL}	Input LOW Current		-1.92	-3.2	mA	V _{CC} = MAX., V _{IN} = 5.0 V
I _{SC} (I _{OS})	Output Short Circuit Current (Note 5)	-20	-50	-70	mA	V _{CC} = MAX., V _{OUT} = 0.0 V
I _{CC}	Power Supply Current		47	82	mA	V _{CC} = MAX.
V _{CD}	Input Clamp Diode Voltage			-1.5	Volts	V _{CC} = MIN., I _{IN} = -12 mA, T _A = 25°C

NOTES:

- (1) The actual testing procedures used to guarantee the Electrical Characteristics are contained in a detailed Customer Sample Specification. A copy of this specification can be obtained from Fairchild Digital Product Marketing, Mountain View, California.
- (2) Conditions for testing, not shown in the Table, are chosen to guarantee operation under "worst case" conditions.
- (3) The specified LIMITS represent the "worst case" value for the parameter. Since these "worst case" values normally occur at the temperature and supply voltage extremes, additional noise immunity and guard banding can be achieved by decreasing the allowable system operating ranges.
- (4) Typical limits are at V_{CC} = 5.0 V, 25°C, and maximum loading.
- (5) Not more than one output should be shorted at a time.

SWITCHING CHARACTERISTICS (T_A = 25°C)

SYMBOL	PARAMETER	MIL LIMITS			IND LIMITS			UNITS	TEST CONDITIONS
		MIN.	TYP.	MAX.	MIN.	TYP.	MAX.		
t _{PLH}	Turn Off Delay Input to Output (I ₄ to PO, Pin 15 to Pin 9)		40	46		40	48	ns	V _{CC} = 5.0 V, C _L = 15 pF Pins 3, 4, 13 & 14 = Gnd Others HIGH
t _{PHL}	Turn On Delay Input to Output (I ₄ to PO, Pin 15 to Pin 9)		36	46		36	48	ns	
t _{PLH}	Turn Off Delay Input to Output (I ₄ to PE, Pin 15 to Pin 10)		47	53		47	55	ns	
t _{PHL}	Turn On Delay Input to Output (I ₄ to PE, Pin 15 to Pin 10)		41	48		41	50	ns	
t _{PLH}	Turn Off Delay Input to Output (I ₃ to PO, Pin 14 to Pin 9)		20	27		20	29	ns	V _{CC} = 5.0 V, C _L = 15 pF Pins 1, 2, 4, 5, 6, 7, 11, 12, 13 & 15 = Gnd Pin 3 HIGH
t _{PHL}	Turn On Delay Input to Output (I ₄ to PO, Pin 15 to Pin 9)		19	25		19	27	ns	V _{CC} = 5.0 V, C _L = 15 pF Pins 1, 2, 3, 4, 5, 6, 7, 11, 12, 13, 14 = Gnd

TTL/MSI 9350

DECADE COUNTER

DESCRIPTION – The TTL/MSI 9350 is a Monolithic Decade Counter. This multifunctional MSI building block is capable of being used as a divide-by-two, divide-by-five or divide-by-ten counter. It is useful in a large number of counting applications in digital computer systems, data handling systems and control systems.

- FUNCTIONALLY EQUIVALENT TO THE 7490
- STANDARD CORNER POWER PINS FOR EASY USE
- HIGH SPEED, 18 MHz TYPICAL
- TYPICAL POWER DISSIPATION OF 160 mW
- TTL COMPATIBLE
- ALL CERAMIC, HERMETIC 14-LEAD DUAL IN-LINE PACKAGE
- INPUT DIODE CLAMPING

PIN NAMES

\overline{CP}_0	Clock First Stage Negative Edge Input
\overline{CP}_1	Clock Second, Third, and Fourth Stage Negative Edge Input
MR	"AND" Master Reset to Binary Zero (Asynchronous) Input
MS	"AND" Master Set to Binary Nine (Asynchronous) Input
Q_0, Q_1, Q_2, Q_3	Counter Outputs (Note b)

LOADING

(Note a)
2 U.L.
4 U.L.
1 U.L.
1 U.L.
10 U.L.

LOGIC SYMBOL

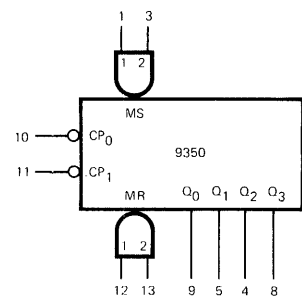

V_{CC} = Pin 14
 GND = Pin 7
 NC = Pins 2, 6

CONNECTION DIAGRAM DIP (TOP VIEW)

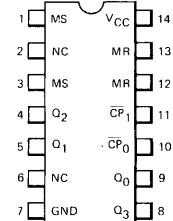

NC – No internal connection

NOTES:

- (a) 1 Unit Load (U.L.) = 40 μ A HIGH/1.6 mA LOW.
 (b) 10 U.L. is the output LOW drive factor and 20 U.L. is the output HIGH drive factor.

LOGIC DIAGRAM

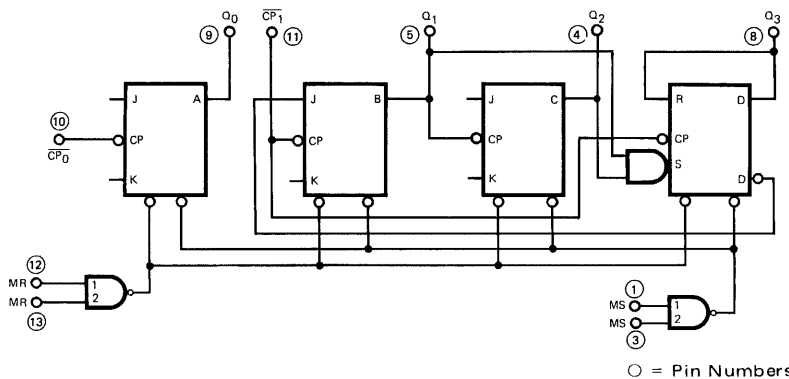

FAIRCHILD TTL/MSI • 9350

FUNCTIONAL DESCRIPTION

The 9350 is an up decade counter. It consists of four dual-rank, master-slave flip-flops internally interconnected to provide a divide-by-two counter and a divide-by-five counter. A gated "AND" Master Reset is provided to inhibit counting and return all outputs to a LOW state. A gated "AND" Master Set is provided which will set the counter to a binary coded decimal count of nine (9), overriding all other count or reset conditions. Since the output from the first flip-flop is not internally connected to the succeeding stages, the device may be operated in three independent count modes:

- A. BCD Decade Counter — The \overline{CP}_1 input must be externally connected to the Q_0 output. The \overline{CP}_0 input receives the incoming count and a BCD count sequence is produced.
- B. Symmetrical Divide-By-Ten Counter — The Q_3 output must be externally connected to the \overline{CP}_0 input. The input count is then applied to the \overline{CP}_1 input and a divide-by-ten square wave is obtained at output Q_0 .
- C. Divide-By-Two & Divide-By-Five Counter — No external interconnections are required. The first flip-flop is used as a binary element for the divide-by-two function. (CP_0 as the input and Q_0 as the output.) The CP_1 input is used to obtain binary divide-by-five operation at the Q_1 , Q_2 , and Q_3 outputs.

NOTE: The 9350 flip-flops change state after the HIGH to LOW transition of the clock.

MODE SELECTION

RESET/SET INPUTS				OUTPUTS			
MR ₁	MR ₂	MS ₁	MS ₂	Q ₀	Q ₁	Q ₂	Q ₃
H	H	L	X	L	L	L	L
H	H	X	L	L	L	L	L
X	X	H	H	H	L	L	H
L	X	L	X		COUNT		
X	L	X	L		COUNT		
L	X	X	L		COUNT		
X	L	L	X		COUNT		

H = HIGH Voltage Level
 L = LOW Voltage Level
 X = Don't Care Condition

BCD COUNT SEQUENCE

COUNT	OUTPUT			
	Q ₀	Q ₁	Q ₂	Q ₃
0	L	L	L	L
1	H	L	L	L
2	L	H	L	L
3	H	H	L	L
4	L	L	H	L
5	H	L	H	L
6	L	H	H	L
7	H	H	H	L
8	L	L	L	H
9	H	L	L	H

NOTE: Output Q_0 is connected to Input CP_1 for BCD count.

ABSOLUTE MAXIMUM RATINGS (above which the useful life may be impaired)

Storage Temperature	-65°C to +150°C
Temperature (Ambient) Under Bias	0°C to +75°C
V _{CC} Pin Potential to Ground Pin	-0.5 V to +7.0 V
*Input Voltage (dc)	-0.5 V to +5.5 V
*Input Current (dc)	-30 mA to +5.0 mA
Voltage Applied to Outputs (Output HIGH)	-0.5 V to +V _{CC} value
Output Current (dc) (Output LOW)	+30 mA

* Either Input Voltage limit or Input Current limit is sufficient to protect the inputs.

RECOMMENDED OPERATING CONDITIONS

PARAMETER	9350XC (IND)			UNITS
	MIN.	TYP.	MAX.	
Supply Voltage V _{CC}	4.75	5.0	5.25	Volts
Operating Free Air Temperature Range	0	25	75	°C
Normalized Fan Out from Each Output, N			10	U.L.
Width of Input Count Pulse, t _{p(in)}	50			ns
Width of Reset Pulse, t _{p(reset)}	50			ns

FAIRCHILD TTL/MSI • 9350

ELECTRICAL CHARACTERISTICS ($T_A = 0^\circ\text{C}$ to $+75^\circ\text{C}$, $V_{CC} = 5.0\text{ V} \pm 5\%$) (Part No. 9350XC*)

SYMBOL	PARAMETER	LIMITS			UNITS	CONDITIONS & COMMENTS
		MIN.	TYP. (Note 4)	MAX.		
V_{IH}	Input HIGH Voltage	2.0			Volts	Guaranteed Input HIGH Threshold Voltage for All Inputs
V_{IL}	Input LOW Voltage			0.8	Volts	Guaranteed Input LOW Threshold Voltage for All Inputs
V_{OH}	Output HIGH Voltage	2.4	3.0		Volts	$V_{CC} = 4.75\text{ V}$, $I_{OH} = -800\ \mu\text{A}$
V_{OL}	Output LOW Voltage		0.2	0.4	Volts	$V_{CC} = 4.75\text{ V}$, $I_{OL} = 16\text{ mA}$
I_{IH}	Input HIGH Current, MS, MR \overline{CP}_0 \overline{CP}_1		10 20 40	40 80 160	μA	$V_{CC} = 5.25\text{ V}$ $V_{IN} = 2.4\text{ V}$
	Input HIGH Current All Inputs			1.0	mA	$V_{CC} = 5.25\text{ V}$, $V_{IN} = 5.5\text{ V}$
I_{IL}	Input LOW Current, MS, MR \overline{CP}_0 \overline{CP}_1		-1.0 -2.0 -4.0	-1.6 -3.2 -6.4	mA	$V_{CC} = 5.25\text{ V}$, $V_{IN} = 0.4\text{ V}$
	Output Short Circuit Current (Note 5)	-18		-57	mA	$V_{CC} = 5.25\text{ V}$, $V_{OUT} = 0\text{ V}$
	Power Supply Current		30	53	mA	$V_{CC} = 5.25\text{ V}$

*X = package type; F for Flatpak, D for Ceramic Dip, P for Plastic Dip. See Packaging Information Section for packages available on this product.

NOTES:

- (1) The actual testing procedures used to guarantee the Electrical Characteristics are contained in a detailed Customer Sample Specification. A copy of this specification can be obtained from Fairchild Digital Product Marketing, Mountain View, California.
- (2) Conditions for testing, not shown in the Table, are chosen to guarantee operation under "worst case" conditions.
- (3) The specified LIMITS represent the "worst case" value for the parameter. Since these "worst case" values normally occur at the temperature and supply voltage extremes, additional noise immunity and guard banding can be achieved by decreasing the allowable system operating ranges.
- (4) Typical limits are at $V_{CC} = 5.0\text{ V}$, 25°C , and max. loading.
- (5) Not more than one output should be shorted at a time.

SWITCHING CHARACTERISTICS ($T_A = 25^\circ\text{C}$)

SYMBOL	PARAMETER	MIN.	TYP.	MAX.	UNITS	CONDITIONS & COMMENTS
t_{PLH}	Turn-Off Delay \overline{CP}_0 to Output Q_2		60	100	ns	$V_{CC} = 5.0\text{ V}$, $C_L = 15\text{ pF}$ Q_0 Output Connected to \overline{CP}_1 Input
t_{PHL}	Turn-On Delay \overline{CP}_0 to Output Q_2		60	100	ns	
f_{max}	Maximum Frequency of Input Count Pulses	10	18		MHz	

SWITCHING TIME WAVEFORMS

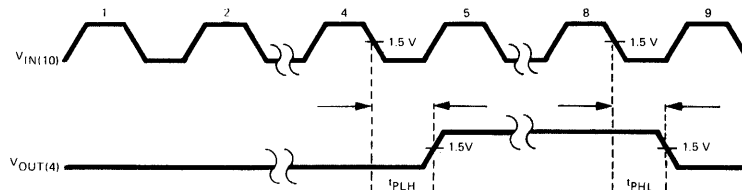

TTL/MSI 9352/5442, 7442 9353/5443, 7443 • 9354/5444, 7444

FOUR LINE TO TEN LINE DECODER (1-OF-10)

DESCRIPTION — These monolithic Decimal Decoders consist of eight inverters and ten 4-input NAND gates. The inverters are connected in pairs to make BCD input data available for decoding by the NAND gates. Full decoding of valid input logic insures that all outputs remain off for all invalid input conditions.

The TTL/MSI 9352/5442, 7442 BCD-to-decimal; TTL/MSI 9353/5443, 7443 excess 3-to-decimal; and TTL/MSI 9354/5444, 7444 excess 3 gray-to-decimal decoders feature familiar transistor-transistor logic (TTL) circuits with inputs and outputs compatible for use with other TTL and DTL circuits. The dc noise margins are typically 1.0V and power dissipation is typically 140 mW. Full fan out of 10 is available at all outputs.

PIN NAMES

A, B, C, D	BCD Inputs (9352)	1 U.L.
A, B, C, D	Excess 3 Inputs (9353)	1 U.L.
A, B, C, D	Excess 3 Gray Inputs (9354)	1 U.L.
0 to 9	Decimal Output	10 U.L.

LOADING

1 Unit Load (U.L.) = 40 μ A HIGH/1.6 mA LOW

LOGIC SYMBOL

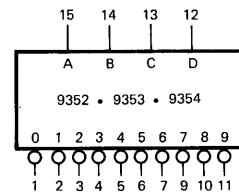

V_{CC} = Pin 16
GND = Pin 8

9352/5442, 7442
9353/5443, 7443
9354/5444, 7444

CONNECTION DIAGRAM DIP (TOP VIEW)

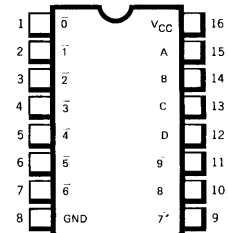

FLATPAK (TOP VIEW)

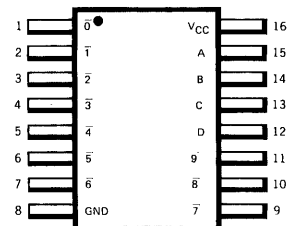

Positive logic: See truth table.

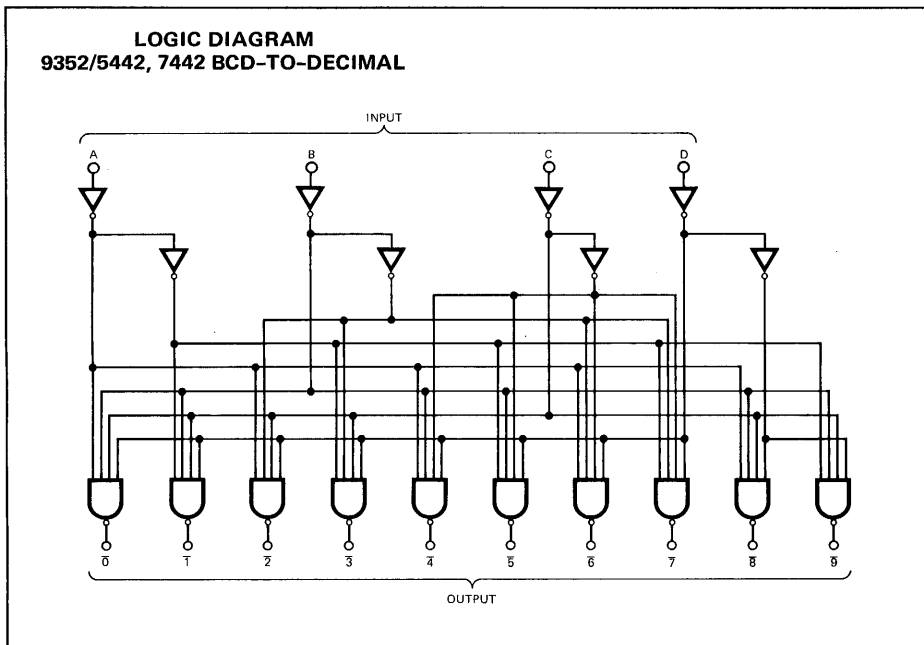

TRUTH TABLES

9352/5442, 7442 BCD INPUT				9353/5443, 7443 EXCESS 3 INPUT				9354/5444, 7444 EXCESS 3 GRAY INPUT				ALL TYPES DECIMAL OUTPUT									
D	C	B	A	D	C	B	A	D	C	B	A	$\bar{0}$	$\bar{1}$	$\bar{2}$	$\bar{3}$	$\bar{4}$	$\bar{5}$	$\bar{6}$	$\bar{7}$	$\bar{8}$	$\bar{9}$
L	L	L	L	L	L	H	H	L	L	H	L	L	H	H	H	H	H	H	H	H	H
L	L	L	H	L	H	L	L	L	H	H	L	H	L	H	H	H	H	H	H	H	H
L	L	H	L	L	H	L	H	L	H	H	H	L	H	H	H	H	H	H	H	H	H
L	L	H	H	L	H	H	L	L	H	L	L	H	L	H	H	H	H	H	H	H	H
L	H	L	L	H	L	L	L	L	H	H	L	L	L	H	L	H	H	H	H	H	H
L	H	L	H	L	H	L	L	L	H	H	L	L	L	H	L	H	H	H	H	H	H
L	H	H	L	L	H	L	L	H	L	H	H	L	L	H	L	H	H	H	H	H	H
L	H	H	H	L	H	L	L	L	H	H	L	L	L	H	L	H	H	H	H	H	H
H	L	L	L	L	H	L	L	L	H	H	L	L	L	H	L	H	H	H	H	H	H
H	L	L	H	L	L	L	L	L	H	H	L	L	L	H	L	H	H	H	H	H	H
H	L	L	H	L	L	L	L	L	H	H	L	L	L	H	L	H	H	H	H	H	H
H	L	H	L	L	L	L	L	L	H	H	L	L	L	H	L	H	H	H	H	H	H
H	L	H	H	L	L	L	L	L	H	H	L	L	L	H	L	H	H	H	H	H	H
H	H	L	L	L	L	L	L	L	H	H	L	L	L	H	L	H	H	H	H	H	H
H	H	L	H	L	L	L	L	L	H	H	L	L	L	H	L	H	H	H	H	H	H
H	H	H	L	L	L	L	L	L	H	H	L	L	L	H	L	H	H	H	H	H	H
H	H	H	L	L	L	L	L	L	H	H	L	L	L	H	L	H	H	H	H	H	H
H	H	H	H	L	L	L	L	L	H	H	L	L	L	H	L	H	H	H	H	H	H
H	H	H	H	L	L	L	L	L	H	H	L	L	L	H	L	H	H	H	H	H	H
H	H	H	H	L	L	L	L	L	H	H	L	L	L	H	L	H	H	H	H	H	H
H	H	H	H	L	L	L	L	L	H	H	L	L	L	H	L	H	H	H	H	H	H
H	H	H	H	L	L	L	L	L	H	H	L	L	L	H	L	H	H	H	H	H	H
H	H	H	H	L	L	L	L	L	H	H	L	L	L	H	L	H	H	H	H	H	H
H	H	H	H	L	L	L	L	L	H	H	L	L	L	H	L	H	H	H	H	H	H
H	H	H	H	L	L	L	L	L	H	H	L	L	L	H	L	H	H	H	H	H	H
H	H	H	H	L	L	L	L	L	H	H	L	L	L	H	L	H	H	H	H	H	H

LOGIC DIAGRAM
9353/5443, 7443 EXCESS 3-TO-DECIMAL

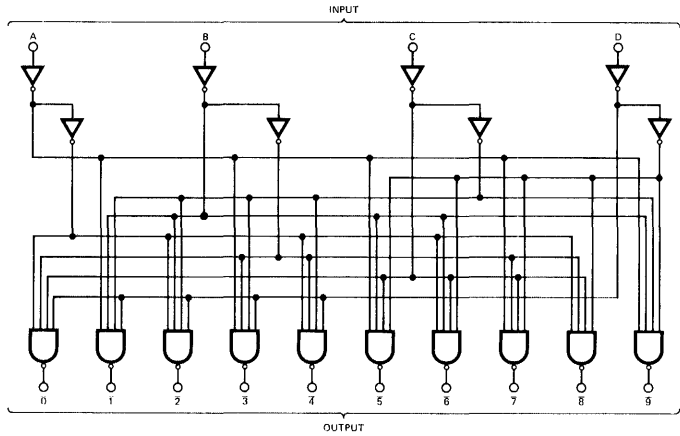

LOGIC DIAGRAM
9354/5444, 7444 EXCESS 3 GRAY-TO-DECIMAL

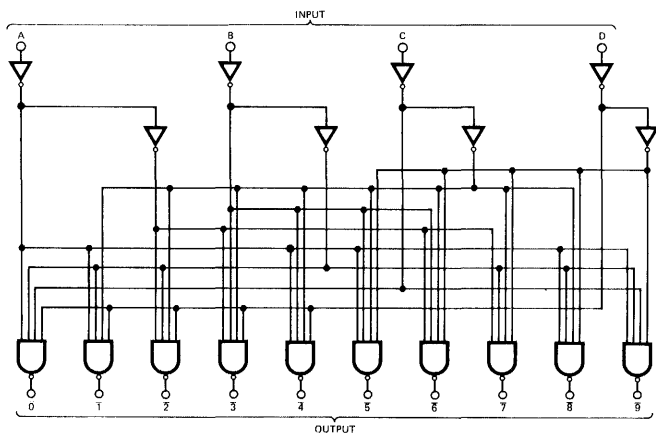

ABSOLUTE MAXIMUM RATINGS (above which the useful life may be impaired)

Storage Temperature	-65°C to +150°C
Temperature (Ambient) Under Bias	-55°C to +125°C
V _{CC} Pin Potential to Ground Pin	-0.5 V to +7.0 V
*Input Voltage (dc)	-0.5 V to +5.5 V
*Input Current (dc)	-30 mA to +5.0 mA
Voltage Applied to Outputs (Output HIGH)	-0.5 V to +V _{CC} value
Output Current (dc) (Output LOW)	+30 mA

*Either Input Voltage limit or Input Current limit is sufficient to protect the inputs.

RECOMMENDED OPERATING CONDITIONS

PARAMETER	9352XM/5442XM			9352XC/7442XC			UNITS
	9353XM/5443XM, 9354XM/5444XM			9353XC/7443XC, 9354XC/7444XC			
	MIN.	TYP.	MAX.	MIN.	TYP.	MAX.	
Supply Voltage V _{CC}	4.5	5.0	5.5	4.75	5.0	5.25	Volts
Operating Free-Air Temperature Range	-55	25	125	0	25	70	°C
Normalized Fan Out from Each Output, N			10			10	U.L.

X = package type; F for Flatpak, D for Ceramic Dip, P for Plastic Dip. See Packaging Information Section for packages available on this product.

ELECTRICAL CHARACTERISTICS OVER OPERATING TEMPERATURE RANGE (Unless Otherwise Noted)

SYMBOL	PARAMETER	LIMITS			UNITS	TEST CONDITIONS (Note 1)	TEST FIGURE
		MIN.	TYP. (Note 2)	MAX.			
V _{IH}	Input HIGH Voltage	2.0			Volts	Guaranteed Input HIGH Voltage	1 & 2
V _{IL}	Input LOW Voltage			0.8	Volts	Guaranteed Input LOW Voltage	1 & 2
V _{OH}	Output HIGH Voltage	2.4			Volts	V _{CC} = MIN., I _{OH} = -0.4 mA, V _{IH} = 2.0 V V _{IL} = 0.8 V	2
V _{OL}	Output LOW Voltage			0.4	Volts	V _{CC} = MIN., I _{OL} = 16 mA, V _{IH} = 2.0 V V _{IL} = 0.8 V	1
I _{IH}	Input HIGH Current			40	μA	V _{CC} = MAX., V _{IN} = 2.4 V	Each Input
				1.0	mA	V _{CC} = MAX., V _{IN} = 5.5 V	
I _{IL}	Input LOW Current			-1.6	mA	V _{CC} = MAX., V _{IN} = 0.4 V	Each Input
I _{OS}	Output Short Circuit Current (Note 3)	-20		-55	mA	9352/5442, 9353/5443, 9354/5444	V _{CC} = MAX.
		-18		-55	mA	9352/7442, 9353/7443, 9354/7444	
I _{CC}	Supply Current		28	41	mA	9352/5442, 9353/5443, 9354/5444	V _{CC} = MAX.
			28	56	mA	9352/7442, 9353/7443, 9354/7444	

SWITCHING CHARACTERISTICS (T_A = 25°C)

SYMBOL	PARAMETER	LIMITS			UNITS	TEST CONDITIONS	TEST FIGURE
		MIN.	TYP.	MAX.			
t _{PHL}	Turn On Delay Input to Output (Through Two Logic Levels)	10	22	30	ns	V _{CC} = 5.0 V C _L = 15 pF R _L = 400Ω	A
t _{PHL}	Turn On Delay Input to Output (Through Three Logic Levels)		23	35			
t _{PLH}	Turn Off Delay Input to Output (Through Two Logic Levels)	10	17	25	ns		A
t _{PLH}	Turn Off Delay Input to Output (Through Three Logic Levels)		26	35			

NOTES:

- (1) For conditions shown as MIN. or MAX., use the appropriate value specified under recommended operating conditions for the applicable device type.
- (2) Typical limits are at V_{CC} = 5.0 V, 25°C.
- (3) Not more than one output should be shorted at a time.

DC TEST CIRCUITS*

PARAMETER MEASUREMENT INFORMATION

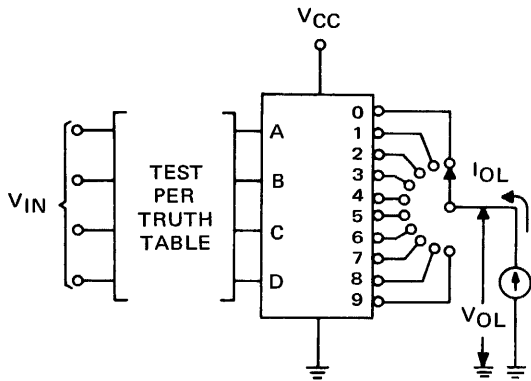

1. Each input is tested separately.

Fig. 1

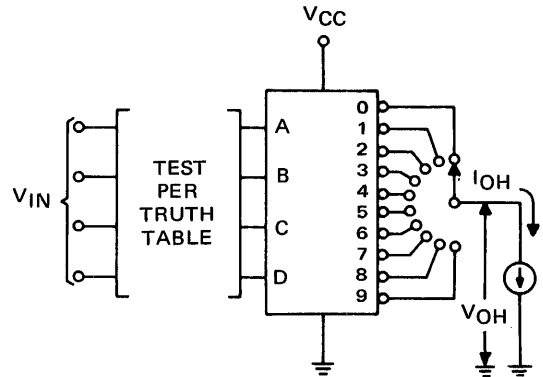

1. Each output is tested separately.

Fig. 2

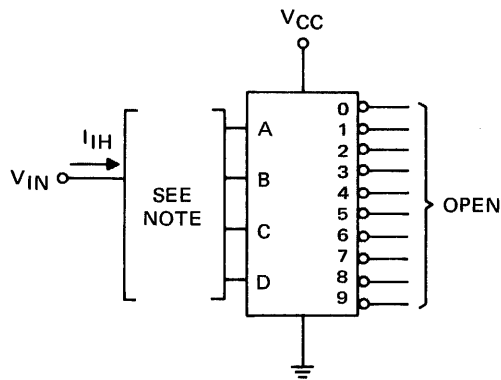

1. Each output is tested separately.

Fig. 3

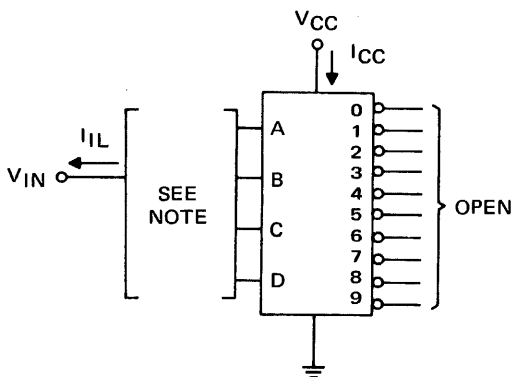

1. When testing I_{IL} each input is tested separately.
2. When testing I_{CC} all inputs are grounded and outputs are open.

Fig. 4

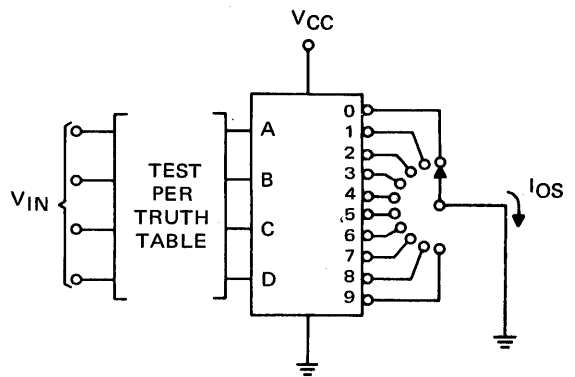

1. Each output is tested separately.

Fig. 5

*Arrows indicate actual direction of current flow.

PARAMETER MEASUREMENT INFORMATION (Con't.)

SWITCHING CHARACTERISTICS

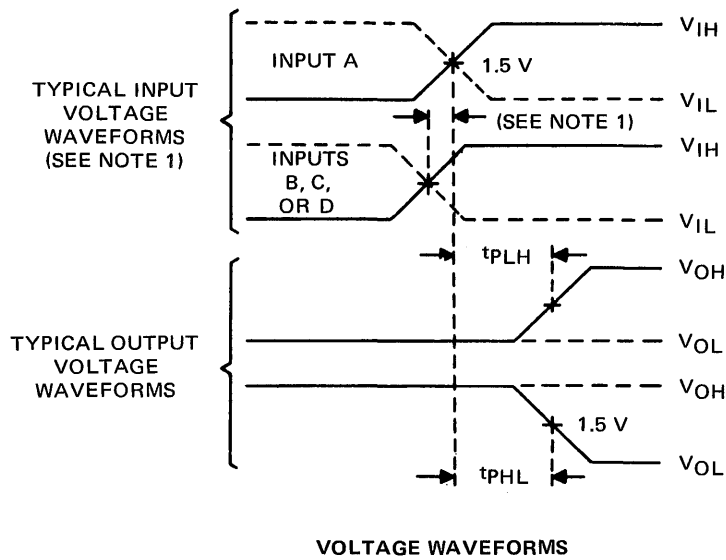
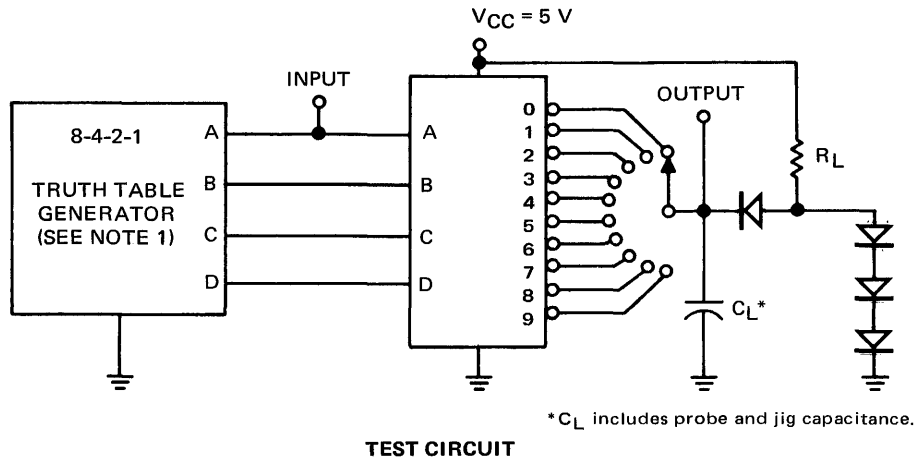

NOTE:

1. The truth table generator has the following characteristics: $V_{OH} \geq 2.4\text{ V}$, $V_{OL} \leq 0.4\text{ V}$, t_r and $t_f < 10\text{ ns}$, and $PRR = 1\text{ MHz}$. Input B, C, and D transitions occur simultaneously with or prior to input A transitions.

Fig. A SWITCHING TIMES

TTL/MSI 9356

4-BIT BINARY COUNTER

DESCRIPTION – The TTL/MSI 9356 is a monolithic 4-Bit Binary Counter. This device is capable of being used as a divided-by-two, divided-by-eight or a divided-by-sixteen counter. It is useful in a large number of counting applications in digital computer systems, data handling systems and control systems.

- FUNCTIONALLY EQUIVALENT TO THE 7493
- STANDARD CORNER POWER PINS FOR EASY USE
- HIGH SPEED, 18 MHz TYPICAL
- TYPICAL POWER DISSIPATION OF 160 mW
- INPUT CLAMP DIODES LIMIT HIGH SPEED TERMINATION EFFECTS
- TTL COMPATIBLE
- ALL CERAMIC, HERMETIC 14-LEAD DUAL IN-LINE PACKAGE

PIN NAMES

\overline{CP}_0	Clock First Stage Negative Edge Input
\overline{CP}_1	Clock Second, Third, and Fourth Stage Negative Edge Input
MR	"AND" Master Reset to Binary Zero (Asynchronous) Input
Q_0, Q_1, Q_2, Q_3	Counter Outputs (Note b)

LOADING

(Note a)

2 U.L.
2 U.L.
1 U.L.
10 U.L.

LOGIC SYMBOL

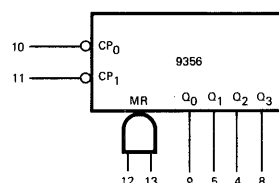

V_{CC} = Pin 14
 Gnd = Pin 7
 NC = Pins 1, 2, 3, 6

CONNECTION DIAGRAM DIP (TOP VIEW)

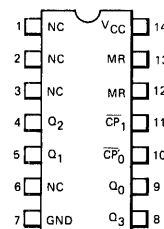

NC – No Internal Connection

NOTES:

- (a) 1 Unit Load (U.L.) = 40 μ A HIGH/1.6 mA LOW.
 (b) 10 U.L. is the output LOW drive factor and 20 U.L. is the output HIGH drive factor.

LOGIC DIAGRAM

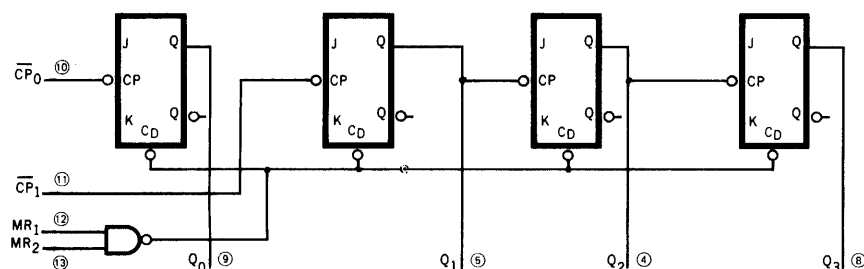

○ = Pin Numbers

FUNCTIONAL DESCRIPTION – The MSI 9356 is an 4-bit up binary counter. It consists of four master-slave flip-flops which are internally interconnected to provide a divide-by-two counter and a divide-by-eight counter. A gated "AND" master reset is provided to inhibit the counting and return all outputs to a LOW state.* Since the output from the first flip-flop is not internally connected to the succeeding flip-flops, the device may be operated in two independent modes:

- A. 4-Bit Ripple Counter – The output Q_0 must be externally connected to input \overline{CP}_1 . The input count pulses are applied to input \overline{CP}_0 . Simultaneous divisions of 2, 4, 8, and 16 are performed at the $Q_0, Q_1, Q_2,$ and Q_3 outputs as shown in the truth table.
- B. 3-Bit Ripple Counter – The input count pulses are applied to input \overline{CP}_1 . Simultaneous frequency divisions of 2, 4 and 8 are available at the Q_1, Q_2 and Q_3 outputs. Independent use of the first flip-flop is available if the reset function coincides with reset of the 3-bit ripple-through counter.

*(i.e., When both inputs of the "AND" master reset are HIGH outputs Q_{0-3} will be forced LOW, resetting the flip-flops, regardless of all other input conditions.)

NOTE: The 9356 flip-flops change state after the HIGH to LOW transition of the clock.

TRUTH TABLE

COUNT	OUTPUT			
	Q_0	Q_1	Q_2	Q_3
0	L	L	L	L
1	H	L	L	L
2	L	H	L	L
3	H	H	L	L
4	L	L	H	L
5	H	L	H	L
6	L	H	H	L
7	H	H	H	L
8	L	L	L	H
9	H	L	L	H
10	L	H	L	H
11	H	H	L	H
12	L	L	H	H
13	H	L	H	H
14	L	H	H	H
15	H	H	H	H

Note: Output Q_0 connected to input \overline{CP}_1 .

MODE SELECTION

RESET INPUTS		OUTPUTS			
MR_1	MR_2	Q_0	Q_1	Q_2	Q_3
H	H	L	L	L	L
L	H		Count		
H	L		Count		
L	L		Count		

H = HIGH Voltage Level
 L = LOW Voltage Level
 X = Don't Care Condition

ABSOLUTE MAXIMUM RATINGS (above which the useful life may be impaired)

Storage Temperature	-65°C to +150°C
Temperature (Ambient) Under Bias	0°C to +75°C
V_{CC} Pin Potential to Ground Pin	-0.5 V to +7.0 V
*Input Voltage (dc)	-0.5 V to +5.5 V
*Input Current (dc)	-30 mA to +5.0 mA
Voltage Applied to Outputs (Output HIGH)	-0.5 V to + V_{CC} value
Output Current (dc) (Output LOW)	+30 mA

*Either Input Voltage limit or Input Current limit is sufficient to protect the inputs.

RECOMMENDED OPERATING CONDITIONS

PARAMETER	LIMITS			UNITS
	MIN.	TYP.	MAX.	
Supply Voltage V_{CC}	4.75	5.0	5.25	Volts
Operating Free-Air Temperature Range	0	25	75	°C
Normalized Fan Out from Each Output, N			10	U.L.
Width of Input Count Pulse, $t_p(in)$	50			ns
Width of Reset Pulse, $t_p(reset)$	50			ns

FAIRCHILD TTL/MSI • 9356

ELECTRICAL CHARACTERISTICS ($T_A = 0^\circ\text{C}$ to $+75^\circ\text{C}$, $V_{CC} = 5.0\text{ V} \pm 5\%$) (Part No. 9356XC*)

SYMBOL	PARAMETER	LIMITS			UNITS	CONDITIONS & COMMENTS
		MIN.	TYP. Note 4	MAX.		
V_{IH}	Input HIGH Voltage	2.0			Volts	Guaranteed Input HIGH Threshold for All Inputs
V_{IL}	Input LOW Voltage			0.8	Volts	Guaranteed Input LOW Threshold for All Inputs
V_{OH}	Output HIGH Voltage	2.4	3.0		Volts	$V_{CC} = 4.75\text{ V}$, $I_{OH} = -800\ \mu\text{A}$
V_{OL}	Output LOW Voltage		0.2	0.4	Volts	$V_{CC} = 4.75\text{ V}$, $I_{OL} = 16\text{ mA}$
I_{IH}	Input HIGH Current, MR $\overline{CP}_0, \overline{CP}_1$		10 20	40 80	μA	$V_{CC} = 5.25\text{ V}$, $V_{IN} = 2.4\text{ V}$
	Input HIGH Current All Inputs			1.0	mA	$V_{CC} = 5.25\text{ V}$, $V_{IN} = 5.5\text{ V}$
I_{IL}	Input LOW Current, MR $\overline{CP}_0, \overline{CP}_1$		-1.0 -2.0	-1.6 -3.2	mA	$V_{CC} = 5.25\text{ V}$, $V_{IN} = 0.4\text{ V}$
	Output Short Circuit Current (Note 5)	-18		-57	mA	$V_{CC} = 5.25\text{ V}$, $V_{OUT} = 0\text{ V}$
I_{CC}	Power Supply Current		30	53	mA	$V_{CC} = 5.25\text{ V}$

* X = package type; F for Flatpak, D for Ceramic Dip, P for Plastic Dip. See Packaging Information Section for packages available on this product.

NOTES:

- (1) The actual testing procedures used to guarantee the Electrical Characteristics are contained in a detailed Customer Sample Specification. A copy of this specification can be obtained from Fairchild Digital Product Marketing, Mountain View, California.
- (2) Conditions for testing, not shown in the Table, are chosen to guarantee operation under "worst case" conditions.
- (3) The specified LIMITS represent the "worst case" value for the parameter. Since these "worst case" values normally occur at the temperature and supply voltage extremes, additional noise immunity and guard banding can be achieved by decreasing the allowable system operating range.
- (4) Typical limits are at $V_{CC} = 5.0\text{ V}$, 25°C , and max. loading.
- (5) Not more than one output should be shorted at a time.

SWITCHING CHARACTERISTICS ($T_A = 25^\circ\text{C}$)

SYMBOL	PARAMETER	MIN.	TYP.	MAX.	UNITS	CONDITIONS & COMMENTS
t_{PLH}	Turn-Off Delay \overline{CP}_0 to Output Q_3		75	135	ns	$V_{CC} = 5.0\text{ V}$, $C_L = 15\text{ pF}$ Q_0 Output Connected To \overline{CP}_1 Input
t_{PHL}	Turn-On Delay \overline{CP}_0 to Output Q_3		75	135	ns	
f_{max}	Maximum Frequency of Input Count Pulses	10	18		MHz	

SWITCHING TIME WAVEFORMS

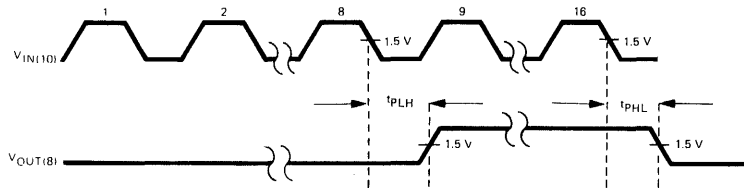

TTL/MSI 9357A/5446, 7446 9357B/5447, 7447 BCD TO 7-SEGMENT DECODER/DRIVER

DESCRIPTION – The 9357A/5446, 7446 and 9357B/5447, 7447 are TTL, BCD to 7-segment Decoder/Drivers consisting of NAND gates, input buffers and seven AND-OR-INVERT gates. They offer active LOW, high sink current outputs for driving indicators directly. Seven NAND gates and one driver are connected in pairs to make BCD data and its complement available to the seven decoding AND-OR-INVERT gates. The remaining NAND gate and three input buffers provide lamp test, blanking input/ripple-blanking output and ripple-blanking input.

The circuits accept 4-bit binary-coded-decimal (BCD) and, depending on the state of the auxiliary inputs, decodes this data to drive a 7-segment display indicator. The relative positive-logic output levels, as well as conditions required at the auxiliary inputs, are shown in the truth tables. Output configurations of the 9357A/5446, 7446; 9357B/5447, 7447 are designed to withstand the relatively high voltages required for 7-segment indicators. The 9357A/5446, 7446 outputs will withstand 30 V and the 9357B/5447, 7447 outputs will withstand 15 V with a maximum reverse current of 250 μ A. Indicator segments requiring up to 20 mA of current may be driven directly from the 9357A/5446, 7446 or 9357B/5447, 7447 high performance output transistors. Display patterns for BCD input counts above nine are unique symbols to authenticate input conditions.

The 9357A/5446, 7446; 9357B/5447, 7447 incorporate automatic leading and/or trailing-edge zero-blanking control (RBI and RBO). Lamp test (LT) of these types may be performed at any time when the BI/RBO node is a HIGH level. Both contain an overriding blanking input (\bar{B}) which can be used to control the lamp intensity or to inhibit the outputs.

PIN NAMES

A, B, C, D	BCD Inputs
\bar{RBI}	Ripple Blanking Input
LT	Lamp Test Input
BI/RBO	Blanking Input or Ripple Blanking Output
\bar{a} , to \bar{g}	Outputs

LOADING

1 U.L.
1 U.L.
1 U.L.
2.6 U.L.
5 U.L.
12.5 U.L.

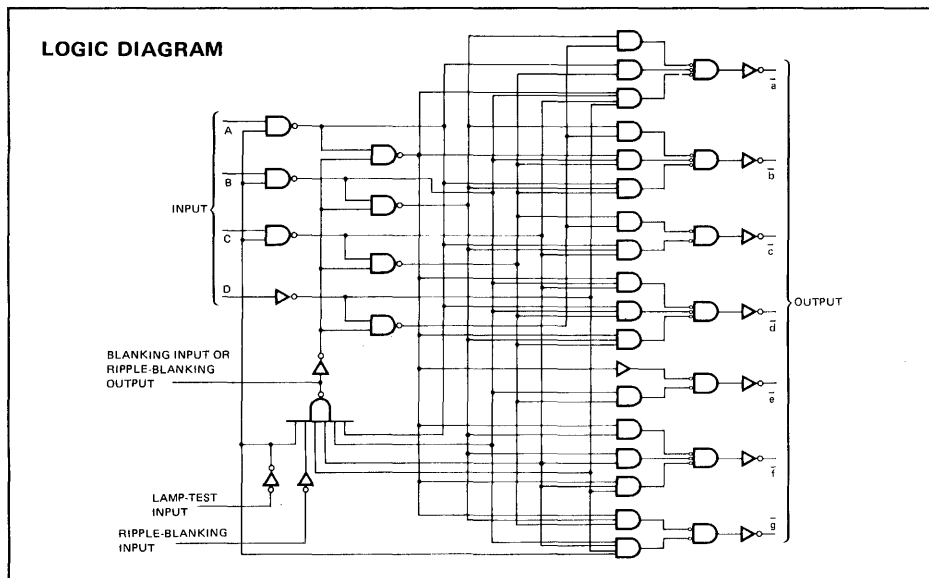

LOGIC SYMBOL

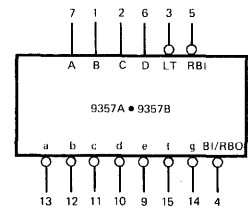

V_{CC} = Pin 16
GND = Pin 8
9357A/5446, 7446
9357B/5447, 7447

**CONNECTION DIAGRAM
DIP (TOP VIEW)**

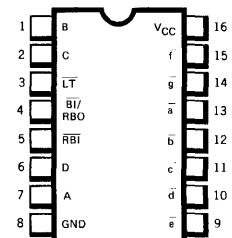

FLATPAK (TOP VIEW)

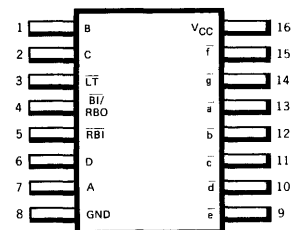

Positive logic: See truth table.

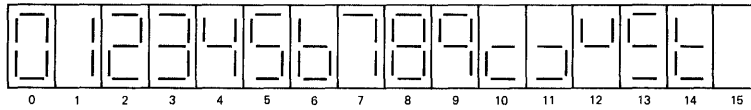

NUMERICAL DESIGNATIONS – RESULTANT DISPLAYS

TRUTH TABLE

DECIMAL OR FUNCTION	INPUTS						OUTPUTS								NOTE
	\overline{LT}	\overline{RBI}	D	C	B	A	$\overline{BI/RBO}$	\overline{a}	\overline{b}	\overline{c}	\overline{d}	\overline{e}	\overline{f}	\overline{g}	
0	H	H	L	L	L	L	H	L	L	L	L	L	L	H	A
1	H	X	L	L	L	H	H	H	L	L	H	H	H	H	A
2	H	X	L	L	H	L	H	L	L	H	L	L	H	L	
3	H	X	L	L	H	H	H	L	L	L	L	H	H	L	
4	H	X	L	H	L	L	H	H	L	L	H	H	L	L	
5	H	X	L	H	L	H	H	L	H	L	L	H	L	L	
6	H	X	L	H	H	L	H	H	H	L	L	L	L	L	
7	H	X	L	H	H	H	H	L	L	L	H	H	H	H	
8	H	X	H	L	L	L	H	L	L	L	L	L	L	L	
9	H	X	H	L	L	H	H	L	L	L	H	H	L	L	
10	H	X	H	L	H	L	H	H	H	H	L	L	H	L	
11	H	X	H	L	H	H	H	H	H	L	L	H	H	L	
12	H	X	H	H	L	L	H	H	L	H	H	H	L	L	
13	H	X	H	H	L	H	H	L	H	H	L	H	L	L	
14	H	X	H	H	H	L	H	H	H	H	L	L	L	L	
15	H	X	H	H	H	H	H	H	H	H	H	H	H	H	
\overline{BI}	X	X	X	X	X	X	L	H	H	H	H	H	H	H	B
\overline{RBI}	H	L	L	L	L	L	L	H	H	H	H	H	H	H	C
\overline{LT}	L	X	X	X	X	X	H	L	L	L	L	L	L	L	D

NOTES:

- (A) $\overline{BI/RBO}$ is wire-AND logic serving as blanking input (\overline{BI}) and/or ripple-blanking output (\overline{RBO}). The blanking out (\overline{BI}) must be open or held at a HIGH level when output functions 0 through 15 are desired, and ripple-blanking input (\overline{RBI}) must be open or at a HIGH level if blanking of a decimal 0 is not desired. X = input may be HIGH or LOW.
- (B) When a LOW level is applied to the blanking input (forced condition) all segment outputs go to a LOW level regardless of the state of any other input condition.
- (C) When ripple-blanking input (\overline{RBI}) and inputs A, B, C, and D are at LOW level, with the lamp test input at HIGH level, all segment outputs go to a HIGH level and the ripple-blanking output (\overline{RBO}) goes to a LOW level (response condition).
- (D) When the blanking input/ripple-blanking output ($\overline{BI/RBO}$) is open or held at a HIGH level, and a LOW level is applied to lamp test input, all segment outputs go to a LOW level.

RECOMMENDED OPERATING CONDITIONS

PARAMETER	9357AXM/5446XM 9357BXM/5447XM			9357AXC/7446XC 9357BXC/7447XC			UNITS
	MIN.	TYP.	MAX.	MIN.	TYP.	MAX.	
Supply Voltage V_{CC} (See Note 3)	4.5	5.0	5.5	4.75	5.0	5.25	Volts
Operating Free-Air Temperature Range	-55	25	125	0	25	70	°C
Normalized Fan Out From Outputs \overline{a} through \overline{g} to Series 54/74 Loads			24			24	
Normalized Fan Out From $\overline{BI/RBO}$ Node to Series 54/74 Loads			5.0			5.0	
Output Sink Current, I_{OL} :	Outputs \overline{a} through \overline{g}		40			40	mA
	$\overline{BI/RBO}$ Node		8.0			8.0	mA

X = package type; F for Flatpak, D for Ceramic Dip, P for Plastic Dip. See Packaging Information Section for packages available on this product.

PARAMETER	9357A/5446, 7446			9357B/5447, 7447			UNITS
	MIN.	TYP.	MAX.	MIN.	TYP.	MAX.	
Continuous Voltage at Outputs \overline{a} through \overline{g}			30			15	Volts

ABSOLUTE MAXIMUM RATINGS (above which the useful life may be impaired)

Storage Temperature	-65°C to +150°C
Temperature (Ambient) Under Bias	-55°C to +125°C
V _{CC} Pin Potential to Ground Pin	-0.5 V to +7.0 V
*Input Voltage (dc)	-0.5 V to +5.5 V
*Input Current (dc)	-30 mA to +5.0 mA
Voltage Applied to Outputs (Output HIGH)	-0.5 V to +V _{CC} value
Output Current (dc) (Output LOW)	+30 mA

*Either Input Voltage limit or Input Current limit is sufficient to protect the inputs.

ELECTRICAL CHARACTERISTICS OVER OPERATING TEMPERATURE RANGE (Unless Otherwise Noted)

SYMBOL	PARAMETER	LIMITS			UNITS	TEST CONDITIONS (Note 1)	TEST FIGURE
		MIN.	TYP. (Note 2)	MAX.			
V _{IH}	Input HIGH Voltage	2.0			Volts	Guaranteed Input HIGH Voltage	1 & 2
V _{IL}	Input LOW Voltage			0.8	Volts	Guaranteed Input LOW Voltage	1 & 2
V _{on}	On-State Output Voltage at Outputs \bar{a} through \bar{g}		0.3	0.4	Volts	V _{CC} = MIN., I _{OL} = 40 mA	1
V _{OL}	Output LOW Voltage at BI/RBO Node		0.3	0.4	Volts	V _{CC} = MIN., I _{OL} = 8.0 mA	1
V _{off}	Off-State Output Voltage at Outputs \bar{a} through \bar{g}	30			Volts	9357A/5446, 7446 V _{CC} = MAX., I _{off} = 250 μ A	2
V _{off}	Off-State Output Voltage at Outputs \bar{a} through \bar{g}	15			Volts	9357B/5447, 7447 V _{CC} = MAX., I _{off} = 250 μ A	2
V _{OH}	Output HIGH Voltage at BI/RBO Node	2.4	3.7		Volts	V _{CC} = MIN., I _{OH} = -0.2 mA	2
I _{IL}	Input LOW Current at Any Input Except BI/RBO Node			-1.6	mA	V _{CC} = MAX., V _{IN} = 0.4 V	3
	Input LOW Current at BI/RBO Node			-4.2	mA	V _{CC} = MAX., V _{IN} = 0.4 V	3
I _{IH}	Input HIGH Current at Any Input Except BI/RBO Node			40	μ A	V _{CC} = MAX., V _{IN} = 2.4 V	4
				1.0	mA	V _{CC} = MAX., V _{IN} = 5.5 V	
I _{OS}	Output Short Circuit Current at BI/RBO Node			-4.0	mA	V _{CC} = MAX.	5
I _{CC}	Supply Current		64	85	mA	9357A/5446, 9357B/5447	4
			64	103	mA	9357A/7446, 9357B/7447	

NOTES:

- (1) For conditions shown as MIN. or MAX., use the appropriate value specified under recommended operating conditions for the applicable device type.
- (2) Typical limits are at V_{CC} = 5.0 V, 25°C.
- (3) These voltage values are with respect to network ground terminal.

SWITCHING CHARACTERISTICS (T_A = 25°C)

SYMBOL	PARAMETER	LIMITS			UNITS	TEST CONDITIONS	TEST FIGURE
		MIN.	TYP.	MAX.			
t _{PLH}	Turn Off Delay Input to Output A Input to Any Output			100	ns	V _{CC} = 5.0 V C _L = 15 pF R _L = 120 Ω	A
t _{PHL}	Turn On Delay Input to Output A Input to Any Output			100	ns		A
t _{PLH}	Turn Off Delay Input to Output \bar{RBI} Input to Any Output			100	ns		A
t _{PHL}	Turn On Delay Input to Output \bar{RBI} Input to Any Output			100	ns		A

PARAMETER MEASUREMENT INFORMATION

DC TEST CIRCUITS*

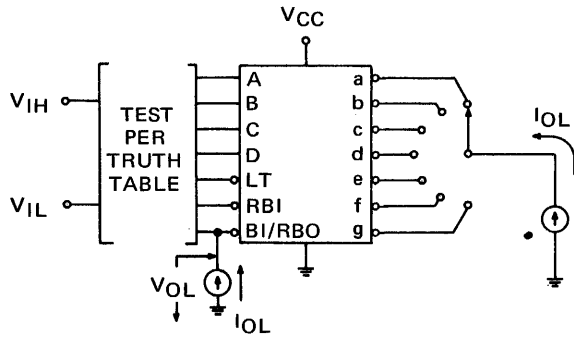

Fig. 1

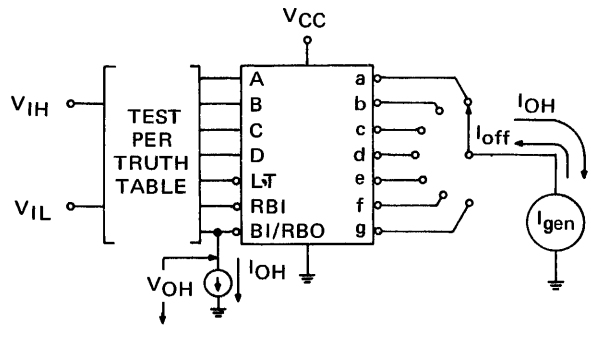
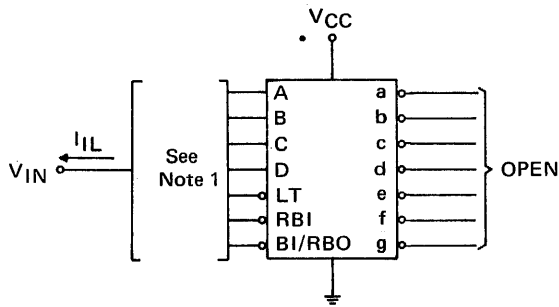
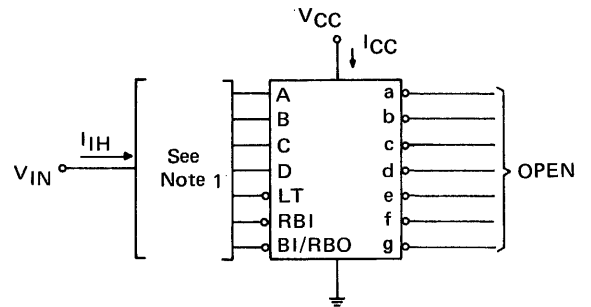

Fig. 2



1. Each input is tested separately.

Fig. 3



1. Each input is tested separately for I_{IH} .

Fig. 4

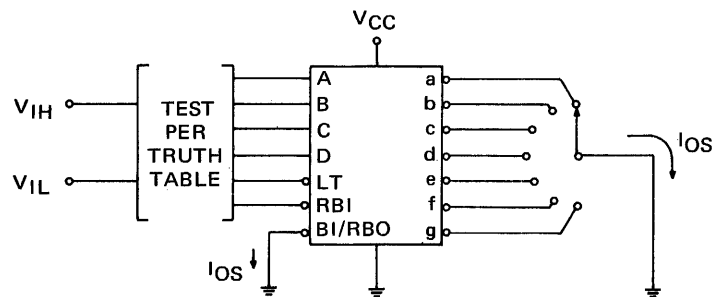

1. Each output is tested separately.

Fig. 5

*Arrows indicate actual direction of current flow. Logic symbol used is representative for all types.

PARAMETER MEASUREMENT INFORMATION (con't.)

SWITCHING CHARACTERISTICS

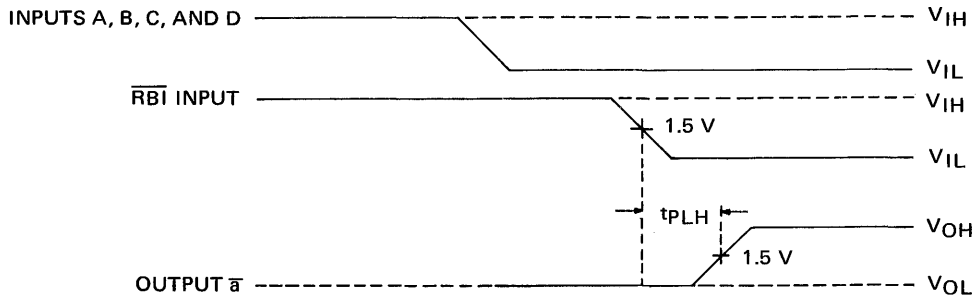
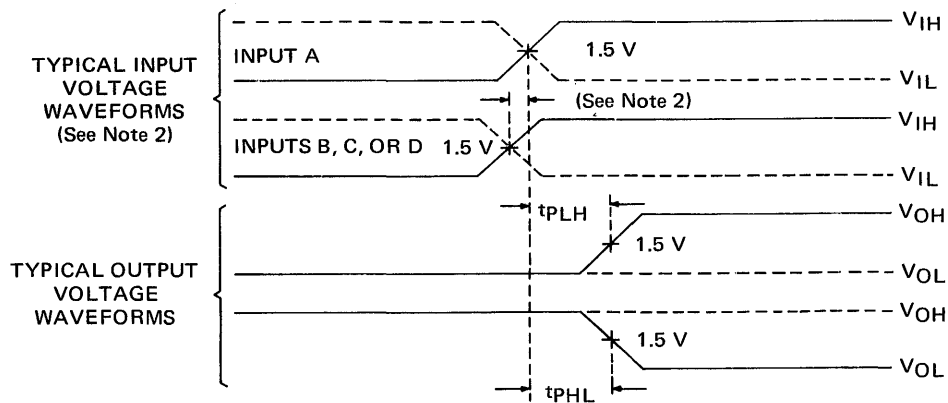
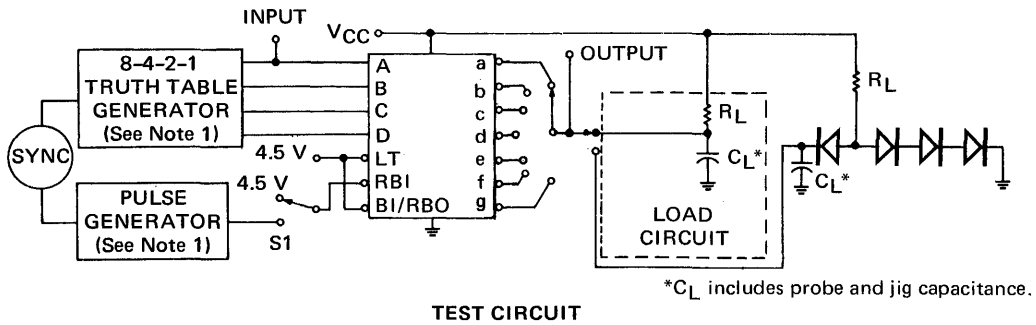

NOTES:

1. The truth table generator and pulse generator have the following characteristics:
 $V_{OH} \geq 2.4 \text{ V}$, $V_{OL} \leq 0.4 \text{ V}$, t_r and $t_f \leq 10 \text{ ns}$, and $PRR = 1 \text{ MHz}$.
2. Inputs B, C, and D transitions occur simultaneously with or prior to input A transitions. $\overline{RBI} = 4.5 \text{ V}$.

Fig. A SWITCHING TIMES

TYPICAL INPUT/OUTPUT VOLTAGE WAVEFORMS

SWITCHING CHARACTERISTICS (Continued)

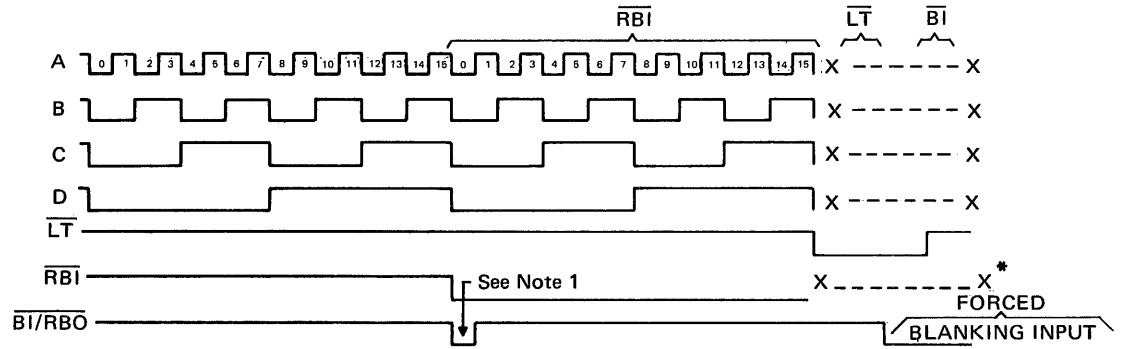

* X - - - - X INPUT MAY BE HIGH OR LOW

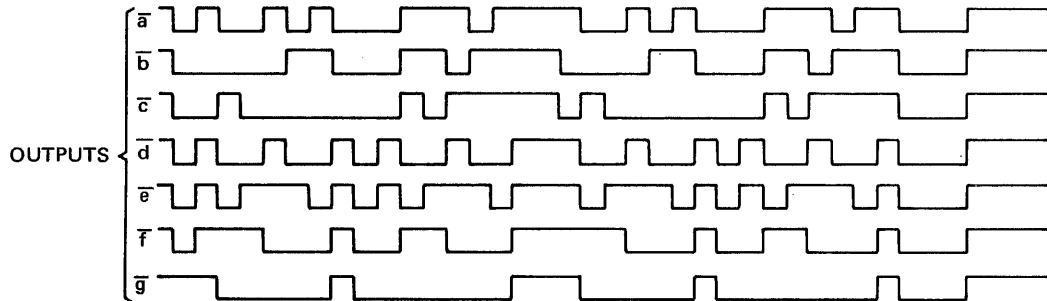

NOTE:

1. This LOW level represents the \overline{RBO} response.

TTL/MSI 9358/5448, 7448

9359/5449, 7449

BCD TO 7-SEGMENT DECODER

DESCRIPTION — The 9358/5448, 7448 and 9359/5449, 7449 are TTL, BCD to 7-Segment Decoders consisting of NAND gates, input buffers and seven AND-OR-INVERT gates. The 9358/5448, 7448 offers active HIGH, open-collector outputs for current-sourcing applications to drive logic circuits or discrete, active components. Seven NAND gates and one driver are connected in pairs to make BCD data and its complement available to the seven decoding AND-OR-INVERT gates. The remaining NAND gate and three input buffers provide lamp test, blanking input/ripple-blanking output and ripple-blanking input for the 9358/5448, 7448. Four NAND gates and four input buffers provide BCD data and its complement and a buffer provides blanking input for the 9359/5449, 7449.

The circuits accept 4-bit binary-coded-decimal (BCD) and, depending on the state of the auxiliary inputs, decodes this data to drive other components. The relative positive-logic output levels, as well as conditions required at the auxiliary inputs are shown in the truth tables.

The 9358/5448, 7448 circuit incorporates automatic leading and/or trailing edge zero-blanking control (RBI and \overline{RBO}). Lamp test (LT) of these types may be performed at any time when the $\overline{BI}/\overline{RBO}$ node is a HIGH level. They contain an overriding blanking input (\overline{BI}) which can be used to control the lamp intensity or to inhibit the outputs.

PIN NAMES

A, B, C, D	BCD Inputs
\overline{RBI}	Ripple Blanking Input
LT	Lamp Test Input
$\overline{BI}/\overline{RBO}$	Blanking Input or Ripple Blanking Output
\overline{BI}	Blanking Input
a to g	Outputs

LOADING

1 U.L.
1 U.L.
1 U.L.
2.6 U.L.
5 U.L.
1 U.L.
6 U.L.

LOGIC DIAGRAM

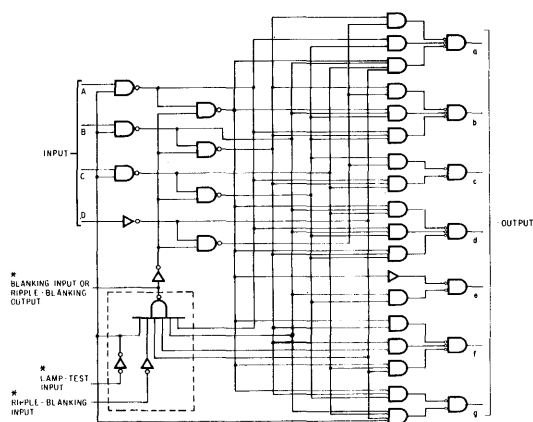

* NOT INCLUDED WITH THE 9359/5449

LOGIC SYMBOL

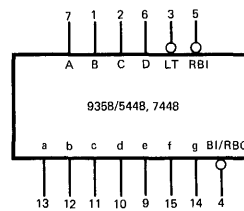

V_{CC} = Pin 16
GND = Pin 8

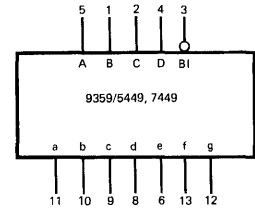

V_{CC} = Pin 14
GND = Pin 7

CONNECTION DIAGRAM FLATPAKS (TOP VIEW)

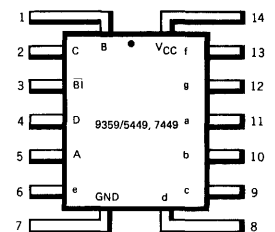
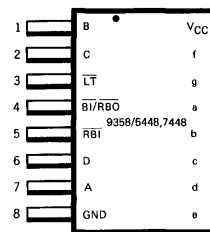

DIP (TOP VIEW)

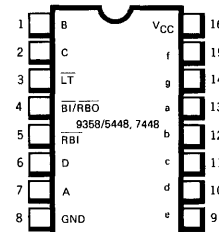

Positive logic: See truth table

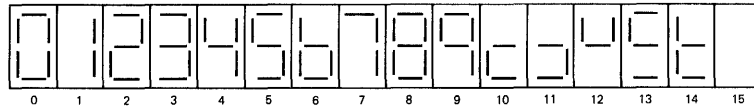

NUMERICAL DESIGNATIONS – RESULTANT DISPLAYS

TRUTH TABLE 9358/5448, 7448

DECIMAL OR FUNCTION	INPUTS					OUTPUTS							NOTE	
	LT	RBI	D	C	B	A	BI/RBO	a	b	c	d	e		f
0	H	H	L	L	L	L	H	H	H	H	H	H	L	1
1	H	X	L	L	L	H	H	L	H	H	L	L	L	1
2	H	X	L	L	H	L	H	H	H	L	H	H	L	H
3	H	X	L	L	H	H	H	H	H	H	L	L	L	H
4	H	X	L	H	L	L	H	L	H	H	L	L	H	H
5	H	X	L	H	L	H	H	H	L	H	H	L	H	H
6	H	X	L	H	H	L	H	L	L	H	H	H	H	H
7	H	X	L	H	H	H	H	H	H	H	L	L	L	L
8	H	X	H	L	L	L	H	H	H	H	H	H	H	H
9	H	X	H	L	L	H	H	H	H	H	L	L	H	H
10	H	X	H	L	H	L	H	L	L	L	H	H	L	H
11	H	X	H	L	H	H	H	L	L	H	H	L	L	H
12	H	X	H	H	L	L	H	L	L	L	L	L	H	H
13	H	X	H	H	L	H	H	H	L	L	H	L	H	H
14	H	X	H	H	H	L	H	L	L	L	H	H	H	H
15	H	X	H	H	H	H	H	L	L	L	L	L	L	L
BI	X	X	X	X	X	X	L	L	L	L	L	L	L	2
RBI	H	L	L	L	L	L	L	L	L	L	L	L	L	3
LT	L	X	X	X	X	X	H	H	H	H	H	H	H	4

NOTES:

- (1) BI/RBO is wired-AND logic serving as blanking input (BI) and/or ripple-blanking output (RBO). The blanking out (BI) must be open or held at a HIGH level when output functions 0 through 15 are desired, and ripple-blanking input (RBI) must be open or at a HIGH level if blanking of a decimal 0 is not desired. X=input may be HIGH or LOW.
- (2) When a LOW level is applied to the blanking input (forced condition) all segment outputs go to a LOW level, regardless of the state of any other input condition.
- (3) When ripple-blanking input (RBI) and inputs A, B, C, and D are at LOW level, with the lamp test input at HIGH level, all segment outputs go to a HIGH level and the ripple-blanking output (RBO) goes to a LOW level (response condition).
- (4) When the blanking input/ripple-blanking output (BI/RBO) is open or held at a HIGH level, and a LOW level is applied to lamp-test input, all segment outputs go to a LOW level.

TRUTH TABLE 9359/5449, 7449

DECIMAL OR FUNCTION	INPUTS					OUTPUTS							NOTE
	D	C	B	A	BI	a	b	c	d	e	f	g	
0	L	L	L	L	H	H	H	H	H	H	L	1	
1	L	L	L	H	H	L	H	H	L	L	L	L	
2	L	L	H	L	H	H	H	L	H	H	L	H	
3	L	L	H	H	H	H	H	H	H	L	L	H	
4	L	H	L	L	H	L	H	H	L	L	H	H	
5	L	H	L	H	H	H	L	H	H	L	H	H	
6	L	H	H	L	H	L	L	H	H	H	H	H	
7	L	H	H	H	H	H	H	L	L	L	L	L	
8	H	L	L	L	H	H	H	H	H	H	H	H	
9	H	L	L	H	H	H	H	H	L	L	H	H	
10	H	L	H	L	H	L	L	L	H	H	L	H	
11	H	L	H	H	H	L	L	H	H	L	L	H	
12	H	H	L	L	H	L	H	L	L	L	H	H	
13	H	H	L	H	H	H	L	L	H	L	H	H	
14	H	H	H	L	H	L	L	L	H	H	H	H	
15	H	H	H	H	H	L	L	L	L	L	L	L	
BI	X	X	X	X	L	L	L	L	L	L	L	2	

NOTES:

- (1) The blanking input must be open or held at a HIGH level when output functions 0 through 15 are desired.
- (2) When a LOW level is applied to the blanking input all segment outputs go to a LOW level regardless of the state of any other input condition. X = input may be HIGH or LOW.

ABSOLUTE MAXIMUM RATINGS (above which the useful life may be impaired)

Storage Temperature	-65°C to +150°C
Temperature (Ambient) Under Bias	-55°C to +125°C
V _{CC} Pin Potential to Ground Pin	-0.5 V to +7.0 V
*Input Voltage (dc)	-0.5 V to +5.5 V
*Input Current (dc)	-30 mA to +5.0 mA
Voltage Applied to Outputs (Output HIGH)	-0.5 V to +V _{CC} value
Output Current (dc) (Output LOW)	+30 mA

*Either Input Voltage limit or Input Current limit is sufficient to protect the inputs.

TTL/MSI • 9358/5448, 7448 • 9359/5449, 7449

RECOMMENDED OPERATING CONDITIONS

PARAMETER	9358XM/5448XM			9358XC/7448XC			UNITS
	9359XM/5449XM			9359XC/7449XC			
	MIN.	TYP.	MAX.	MIN.	TYP.	MAX.	
Supply Voltage V_{CC} (See Note 3)	4.5	5.0	5.5	4.75	5.0	5.25	Volts
Operating Free-Air Temperature Range	-55	25	125	0	25	70	°C

X = package type; F for Flatpak, D for Ceramic Dip, P for Plastic Dip. See Packaging Information Section for packages available on this product.

PARAMETER	9358/5448, 7448			9359/5449, 7449			UNITS
	MIN.	TYP.	MAX.	MIN.	TYP.	MAX.	
Continuous Voltage at Outputs a through g						5.5	Volts
Normalized Fan Out From Outputs a through g to Series 54/74 Loads			4.0			6.0	
Normalized Fan Out From BI/RBO Node to Series 54/74 Loads			5.0				
Output Sink Current, I_{OL} :	Outputs a through g		6.4			10	mA
	BI/RBO Node		8.0				mA

ELECTRICAL CHARACTERISTICS OVER OPERATING TEMPERATURE RANGE (Unless Otherwise Noted)

SYMBOL	PARAMETER	LIMITS			UNITS	TEST CONDITIONS (Note 1)	TEST FIGURE	
		MIN.	TYP. (Note 2)	MAX.				
V_{IH}	Input HIGH Voltage	2.0			Volts		1 & 2	
V_{IL}	Input LOW Voltage			0.6 0.8	Volts	9359/5449 9358/5448, 7448; 9359/7449	1 & 2	
V_{on}	On-State Output Voltage		0.27	0.4	Volts	9359/5449, 7449 $V_{CC} = \text{MIN.}$ $I_{OL} = \text{MAX.}$	1	
V_{OL}	Output LOW Voltage		0.27	0.4	Volts	9358/5448, 7448 $V_{CC} = \text{MIN.}$ $I_{OL} = \text{MAX.}$	1	
V_{off}	Off-State Output Voltage	5.5			Volts	9359/5449, 7449 $V_{CC} = \text{MAX.}$ $I_{off} = 0.25 \text{ mA}$	2	
V_{OH}	Output HIGH Voltage at BI/RBO Node	2.4	3.7		Volts	9358/5448, 7448 $V_{CC} = \text{MIN.}$ $I_{OH} = -0.2 \text{ mA}$	2	
	Output HIGH Voltage at Outputs a through g	2.4	4.2		Volts	9358/5448, 7448 $V_{CC} = \text{MIN.}$ $I_{OH} = -0.4 \text{ mA}$	2	
I_{OH}	Output HIGH Current at Outputs a through g	-1.3	-2.0		mA	9358/5448, 7448 $V_{CC} = \text{MIN.}$ $V_{OUT} = 0.85 \text{ V}$	2	
I_{IL}	Input LOW Current at Any Input Except BI/RBO Node of 9358/5448, 7448			-1.6	mA	$V_{CC} = \text{MAX.}, V_{IN} = 0.4 \text{ V}$	3	
	Input LOW Current at BI/RBO Node			-4.2	mA	9358/5448, 7448 $V_{CC} = \text{MAX.}$ $V_{IN} = 0.4 \text{ V}$	3	
I_{IH}	Input HIGH Current at Any Input Except BI/RBO Node of 9358/5448, 7448			40	μA	$V_{CC} = \text{MAX.}, V_{IN} = 2.4 \text{ V}$	4	
				1.0	mA	$V_{CC} = \text{MAX.}, V_{IN} = 5.5 \text{ V}$		
I_{OS}	Output Short Circuit Current at Any Output Except Outputs a through g 9359/5449, 7449			-4.0	mA	$V_{CC} = \text{MAX.}$	5	
I_{CC}	Supply Current		53	76	mA	9358/5448	$V_{CC} = \text{MAX.}$	4
			53	90	mA	9358/7448		
			33	47	mA	9359/5449		
			33	56	mA	9359/7449		

SWITCHING CHARACTERISTICS ($T_A = 25^\circ\text{C}$)

SYMBOL	PARAMETER	LIMITS			UNITS	TEST CONDITIONS	TEST FIGURE
		MIN.	TYP.	MAX.			
t_{PLH}	Turn Off Delay Input to Output A Input to Any Output			100	ns	$V_{CC} = 5.0 \text{ V}$ $C_L = 15 \text{ pF}$ R_L^*	A
t_{PHL}	Turn On Delay Input to Output A Input to Any Output			100	ns		A
t_{PLH}	Turn Off Delay Input to Output RBI Input to Any Output			100	ns		A
t_{PHL}	Turn On Delay Input to Output RBI Input to Any Output			100	ns		A

* $R_L = 1 \text{ k}\Omega$ for 9358/5448 and 9359/5449; $R_L = 667 \Omega$ for 9358/7448 and 9359/7449.

NOTES:

- (1) For conditions shown as MIN. or MAX., use the appropriate value specified under recommended operating conditions for the applicable device type.
- (2) Typical limits are at $V_{CC} = 5.0 \text{ V}, 25^\circ\text{C}$.
- (3) These voltage values are with respect to network ground terminal.

PARAMETER MEASUREMENT INFORMATION

DC TEST CIRCUITS*

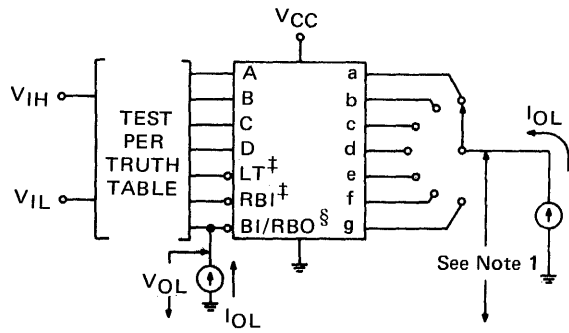

1. Measure V_{OL} for 9359/5449, 7449.
Measure V_{OL} for 9358/5448, 7448.

Fig. 1

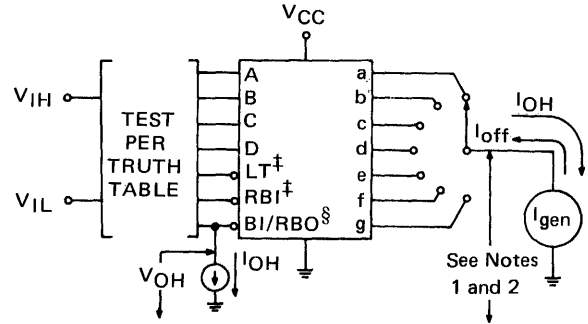

1. Measure V_{off} for 9359/5449, 7449.
2. Measure V_{OH} for 9358/5448, 7448.

Fig. 2

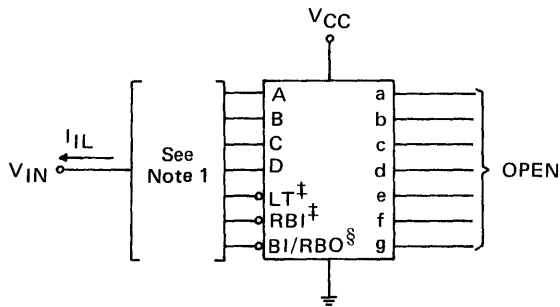

1. Each input is tested separately.

Fig. 3

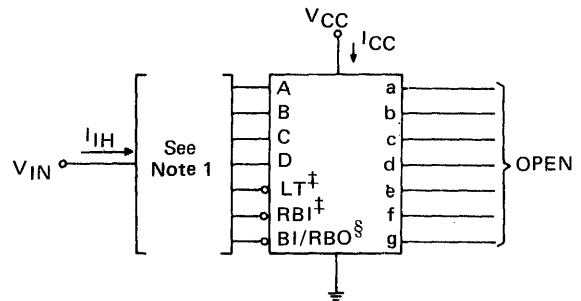

1. Each input is tested separately for I_{IH} .

Fig. 4

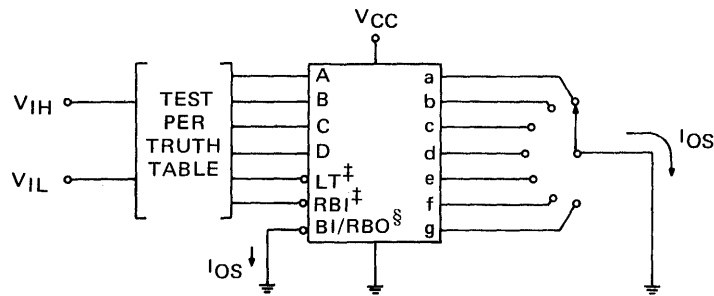

1. Each output is tested separately.

Fig. 5

* Arrows indicate actual direction of current flow. Logic symbol used is representative for all types.

† Available on 9358/5448, 7448 only.

§ BI is available on all types. RBO node is available on 9358/5448, 7448 only.

PARAMETER MEASUREMENT INFORMATION (con't.)

SWITCHING CHARACTERISTICS

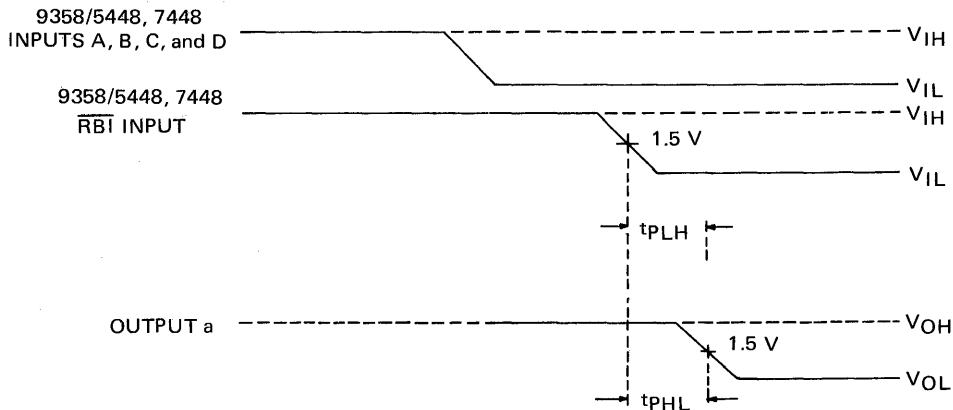
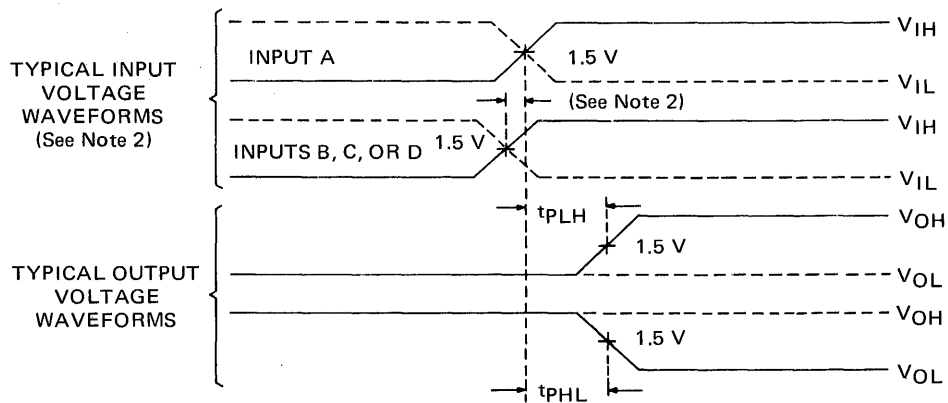
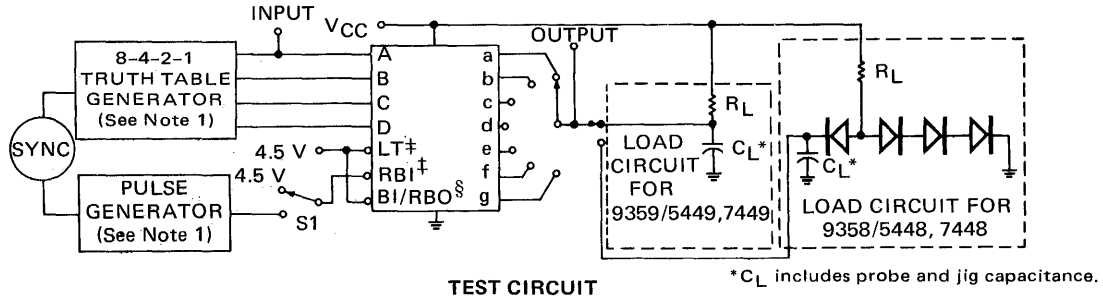

NOTES:

1. The truth table generator and pulse generator have the following characteristics:
 $V_{OH} \geq 2.4 \text{ V}$, $V_{OL} \leq 0.4 \text{ V}$, t_r and $t_f \leq 10 \text{ ns}$, and $PRR = 1 \text{ MHz}$.
2. Inputs B, C, and D transitions occur simultaneously with or prior to input A transitions. $RBI = 4.5 \text{ V}$.

‡ Available on 9358/5448, 7448 only.

§ BI is available on all types. RBO node is available on 9358/5448, 7448 only.

Fig. A SWITCHING TIMES

TYPICAL INPUT/OUTPUT VOLTAGE WAVEFORMS

SWITCHING CHARACTERISTICS (Continued)

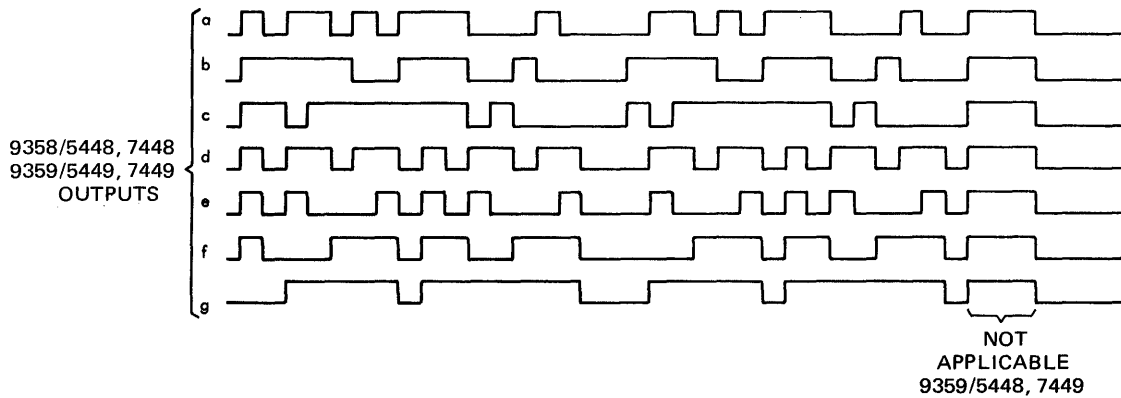
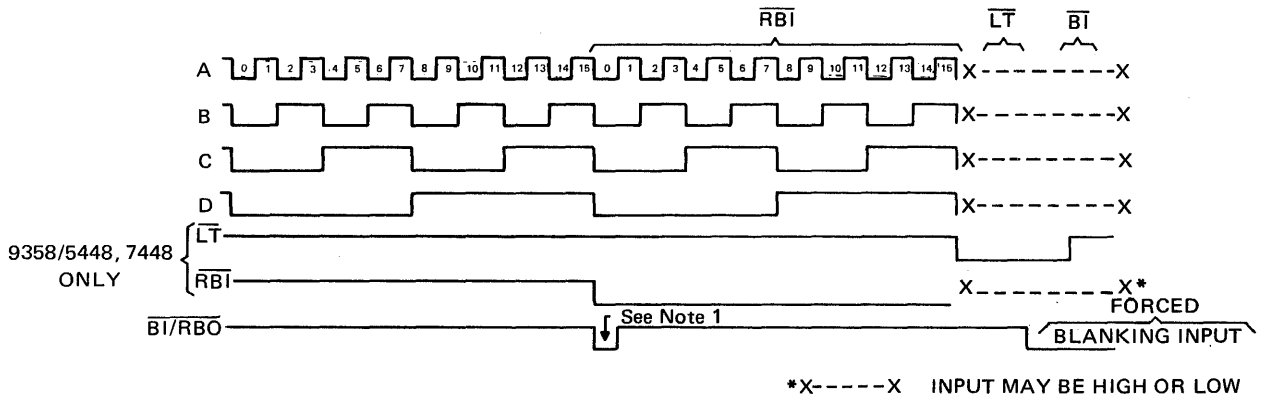

NOTE:

1. For the 9358/5448, 7448 this LOW level represents the \overline{RBO} response.
For the 9359/5449, 7449 a LOW level pulse is applied to the blanking input.

TTL/MSI 9360/54192, 74192

9366/54193, 74193

UP/DOWN DECADE AND BINARY COUNTERS

DESCRIPTION – The TTL/MSI 9360/54192, 74192 is a synchronous Up/Down BCD Decade Counter, and the TTL/MSI 9366/54193, 74193 is a synchronous Up/Down 4-Bit Binary Counter. Both counters have separate up/down clocks, parallel load facility, terminal count outputs for multidecade operation and an asynchronous overriding master reset. The circuits use TTL technology for high speed, and are compatible with the entire Fairchild TTL family.

- SYNCHRONOUS OPERATION
- CASCADING CIRCUITRY INTERNALLY PROVIDED
- PARALLEL LOAD FACILITY
- ASYNCHRONOUS MASTER RESET
- 30MHz TYPICAL COUNT FREQUENCY
- TYPICAL POWER DISSIPATION OF 300mW
- INPUT CLAMP DIODES
- ALL CERAMIC "HERMETIC" 16-LEAD DUAL IN-LINE PACKAGE
- TTL COMPATIBLE

PIN NAMES

\overline{PL}	Parallel Load (Active LOW) Input
P_A, P_B, P_C, P_D	Parallel Data Inputs
CP_U	Count Up Clock Pulse Input
CP_D	Count Down Clock Pulse Input
MR	Master Reset (Clear) Input (Asynchronous)
Q_A, Q_B, Q_C, Q_D	Counter Outputs
TC_U	Terminal Count Up (Carry) Output
TC_D	Terminal Count Down (Borrow) Output

1 Unit Load (U.L.) = 40 μ A HIGH/1.6 mA LOW

LOADING

1 U.L.
1 U.L.
1 U.L.
1 U.L.
1 U.L.
10 U.L.
10 U.L.
10 U.L.

LOGIC SYMBOL

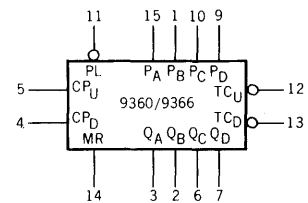

9360/54192, 74192 & 9366/54193, 74193

V_{CC} = Pin 16
GND = Pin 8

CONNECTION DIAGRAMS (TOP VIEWS)

DIP

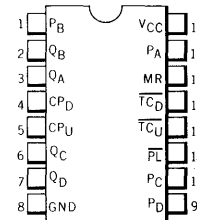

FLATPAK

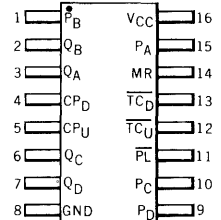

LOGIC DIAGRAMS

9360/54192, 74192

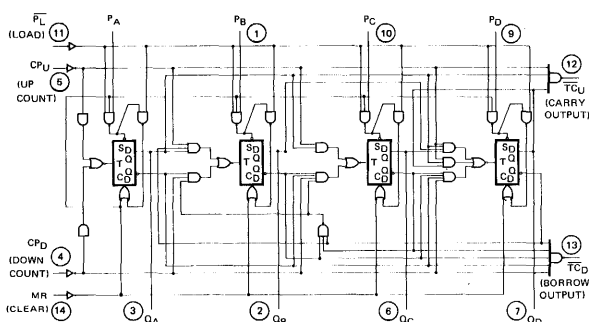

9366/54193, 74193

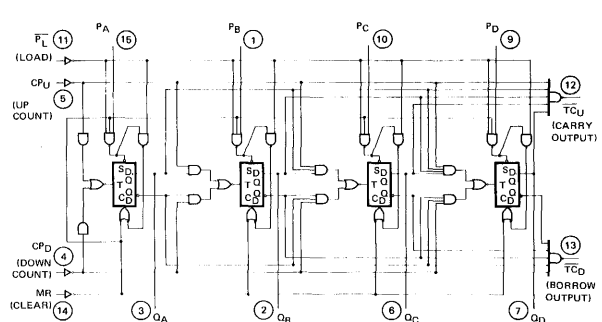

○ = PIN NUMBER

FUNCTIONAL DESCRIPTION — The 9360/54192, 74192 and 9366/54193, 74193 can be reset, preset and count up or down. These operating modes of the 9360/54192, 74192 and 9366/54193, 74193 are tabulated in Mode Selection table. The operating modes of the 9360/54192, 74192 and 9366/54193, 74193 are identical; the only difference between the devices is the count sequences.

Counting is synchronous, with the outputs changing state after the LOW to HIGH transition of either the Count-Up Clock (CP_U) or Count-Down Clock (CP_D). The direction of counting is determined by which clock input is pulsed while the other clock input is HIGH. (Incorrect counting will occur if both the count-up clock and count-down clock inputs are LOW simultaneously.) Both counters will respond to a clock pulse on either input by changing to the next appropriate state of the count sequence. (The state diagram for the 9360/54192, 74192 shows the regular sequence and in addition shows the sequence of states if a code greater than nine is present in the counter.

Both the 9360/54192, 74192 and the 9366/54193, 74193 have a parallel load (asynchronous) facility which permits the counter to be preset. Whenever the parallel load (PL) input is LOW, and Master Reset is LOW, the information present on the Parallel Data inputs (P_A, P_B, P_C, P_D) will be loaded into the counters and appear on the outputs independent of the conditions of the clock inputs. When the Parallel Load Input goes HIGH this information is stored in the counters and when the counters are clocked they change to the next appropriate state in the count sequence. The Parallel Data inputs are inhibited when the Parallel Load is HIGH and have no effect on the counters.

The Terminal Count-Up (\overline{TC}_U) and Terminal Count-Down (\overline{TC}_D) outputs (carry and borrow respectively) allow multidecade counter operations without additional logic. The counters are cascaded by feeding the terminal count-up output to the count-up clock input and terminal count-down clock input of the following counter.

The terminal count-up outputs for the 9360/54192, 74192 and 9366/54193, 74193 are LOW when their count-up clock inputs are LOW and the counters are in state nine and state fifteen respectively. Similarly, the terminal count-down outputs are LOW when their count-down clock inputs are LOW and both counters are in state zero. Thus, when the 9360/54192, 74192 counter is in state nine and the 9366/54193, 74193 counter is in state fifteen and both are counting up, or both counters are in state zero and counting down, a clock pulse will change the counter's state on the rising edge and simultaneously clock the following counter through the appropriate active LOW terminal count output. There are two gate delays per state when these counters are cascaded.

The asynchronous Master Reset input (MR), when HIGH, overrides all input and clears the counters. Master reset overrides parallel load so that when both are activated the counters will be reset. (Obviously, both parallel load and master reset must not be deactivated simultaneously for predictable operation).

9360/54192, 74192 LOGIC EQUATIONS FOR TERMINAL COUNT

$$TC_U = Q_0 \cdot \overline{Q_1} \cdot \overline{Q_2} \cdot Q_3 \cdot \overline{CP_U}$$

$$TC_D = \overline{Q_0} \cdot \overline{Q_1} \cdot \overline{Q_2} \cdot \overline{Q_3} \cdot \overline{CP_D}$$

9366/54193, 74193 LOGIC EQUATIONS FOR TERMINAL COUNT

$$TC_U = Q_0 \cdot Q_1 \cdot Q_2 \cdot Q_3 \cdot \overline{CP_U}$$

$$TC_D = \overline{Q_0} \cdot \overline{Q_1} \cdot \overline{Q_2} \cdot \overline{Q_3} \cdot \overline{CP_D}$$

9360/54192, 74192 STATE DIAGRAM

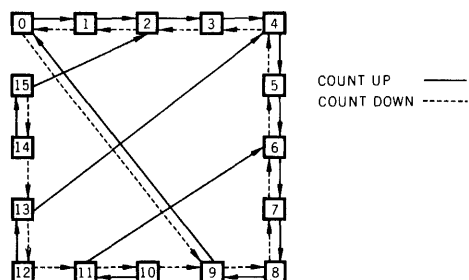

9366/54193, 74193 STATE DIAGRAM

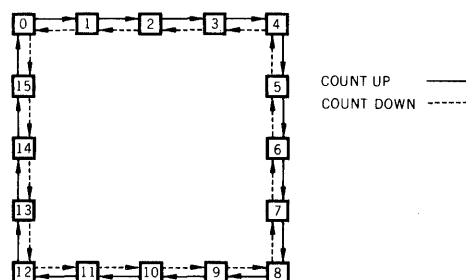

MODE SELECTION (Both Counters)

MR	\overline{PL}	CP _U	CP _D	MODE
H	X	X	X	Preset (Asyn.)
L	L	X	X	Preset (Asyn.)
L	H	H	H	No Change
L	H	CP	H	Count Up
L	H	H	CP	Count Down

H = HIGH Voltage Level X = Don't Care Condition
L = LOW Voltage Level CP = Clock Pulse

ABSOLUTE MAXIMUM RATINGS (above which the useful life may be impaired)

Storage Temperature	-65°C to +150°C
Temperature (Ambient) Under Bias	-55°C to +125°C
V _{CC} Pin Potential to Ground Pin	-0.5 V to +7.0 V
*Input Voltage (dc)	-0.5 V to +5.5 V
*Input Current (dc)	-30 mA to +5.0 mA
Voltage Applied to Outputs (Output HIGH)	-0.5 V to +V _{CC} value
Output Current (dc) (Output LOW)	+30 mA

*Either Input Voltage limit or Input Current limit is sufficient to protect the inputs.

RECOMMENDED OPERATING CONDITIONS

PART NUMBER	SUPPLY VOLTAGE (V _{CC})			TEMPERATURE
	MIN.	TYP.	MAX.	
9360XM/54192XM; 9366XM/54193XM	4.5 V	5.0 V	5.5 V	-55°C to 125°C
9360XC/74192XC; 9366XC/74193XC	4.75 V	5.0 V	5.25 V	0°C to 75°C

X = package type; F for Flatpak, D for Ceramic Dip, P for Plastic Dip. See Packaging Information Section for packages available on this product.

ELECTRICAL CHARACTERISTICS OVER OPERATING TEMPERATURE RANGE (Unless Otherwise Noted)

SYMBOL	PARAMETER	LIMITS			UNITS	TEST CONDITIONS (Note 1)
		MIN.	TYP. (Note 2)	MAX.		
V _{IH}	Input HIGH Voltage	2.0			Volts	Guaranteed input HIGH Threshold voltage for all inputs
V _{IL}	Input LOW Voltage			0.8	Volts	Guaranteed input LOW Threshold voltage for all inputs
V _{OH}	Output HIGH Voltage	2.4			Volts	V _{CC} = MIN., I _{OH} = -400µA, V _{IH} = 2.0 V, V _{IL} = 0.8V
V _{OL}	Output LOW Voltage			0.4	Volts	V _{CC} = MIN., I _{OL} = 16mA, V _{IH} = 2.0V, V _{IL} = 0.8V
I _{IH}	Input HIGH Current			40	µA	V _{CC} = MAX., V _{IN} = 2.4V
				1.0	mA	V _{CC} = MAX., V _{IN} = 5.5V
I _{IL}	Input LOW Current			-1.6	mA	V _{CC} = MAX., V _{IN} = 0.4V
I _{SC} (I _{OS})	Output Short Circuit Current (Note 3)	-18		-65	mA	V _{CC} = MAX.
I _{CC}	Power Supply Current		65	102	mA	V _{CC} = MAX.

NOTES:

- (1) For conditions shown as MIN. or MAX., use the appropriate value specified under recommended operating conditions for the applicable device type.
- (2) Typical limits are at V_{CC} = 5.0V, 25°C.
- (3) Not more than one output should be shorted at a time.

SWITCHING CHARACTERISTICS (T_A = 25°C)

SYMBOL	PARAMETER	LIMITS			UNITS	TEST CONDITIONS
		MIN.	TYP.	MAX.		
f _{max}	Maximum Input Count Frequency		30		MHz	V _{CC} = 5.0V, C _L = 15pF, R _L = 400Ω
t _{PLH}	Turn Off Delay, Count-Up Input (C _{P_U}) to Carry Output (TC _U)		22	26	ns	V _{CC} = 5.0 V C _L = 15 pF R _L = 400 Ω
t _{PHL}	Turn On Delay, Count-Up Input (C _{P_U}) to Carry Output (TC _U)		18	24	ns	
t _{PLH}	Turn Off Delay, Count-Down Input (C _{P_D}) to Borrow Output (TC _D)		22	24	ns	V _{CC} = 5.0 V C _L = 15 pF R _L = 400 Ω
t _{PHL}	Turn On Delay, Count-Down Input (C _{P_D}) to Borrow Output (TC _D)		18	24	ns	
t _{PLH}	Turn Off Delay, Either Count Input to Q Output		27	38	ns	V _{CC} = 5.0 V C _L = 15 pF R _L = 400 Ω
t _{PHL}	Turn On Delay, Either Count Input to Q Output		37	47	ns	

TTL/MSI 93S62

9-INPUT PARITY CHECKER/GENERATOR

TO BE ANNOUNCED

DESCRIPTION — The TTL/MSI 93S62 is a very high speed 9-input parity checker/generator for use in error detection in data transmission applications. The 93S62 is implemented with Schottky barrier diode clamped TTL technology to insure high speed.

The 93S62 provides odd and even parity for up to nine data bits. The even parity output (PE) will be HIGH if an even number of logic ones are present on the inputs. The odd parity output (PO) will be HIGH if an odd number of logic ones are present. An enable input (\bar{E}) is provided which forces both outputs to a LOW level when the input is HIGH.

- INPUT TO OUTPUT DELAY 16 ns
- OUTPUT ENABLE TERMINAL
- BOTH ODD AND EVEN PARITY OUTPUTS PROVIDED
- GENERATES A PARITY BIT FOR UP TO NINE BITS
- CHECKS FOR PARITY ON UP TO NINE BITS
- EASILY EXPANDABLE
- SCHOTTKY-CLAMPED TTL DESIGN

PIN NAMES

I_0 to I_8	Data Inputs
\bar{E}	Output Enable
PO	Odd parity output
PE	Even parity output

LOGIC SYMBOL

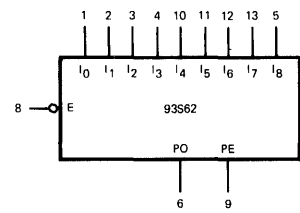

V_{CC} = PIN 14
GND = PIN 7

CONNECTION DIAGRAM DIP (TOP VIEW)

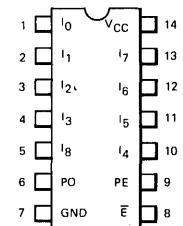

LOGIC DIAGRAM

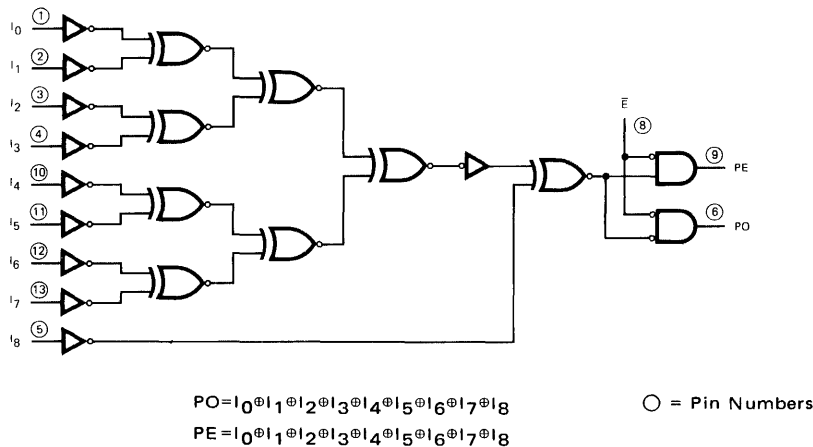

TTL/MSI 93H72

HIGH SPEED 4-BIT SHIFT REGISTER WITH ENABLE

DESCRIPTION — The 93H72 High Speed MSI 4-Bit Shift Register is a multifunctional sequential logic block which is useful in a wide variety of register applications. It may be used in serial-serial, shift left, shift right, serial-parallel, parallel-serial and parallel-parallel data transfers. The circuit is compatible with all Fairchild 9300 MSI/TTL Integrated circuits.

The 93H72 has three synchronous modes of operation: shift, parallel load and hold (do nothing). The hold capability permits information storage in the register independent of the clock.

- 60 MHz TYPICAL SHIFT FREQUENCY
- SYNCHRONOUS PARALLEL ENTRY
- DATA HOLD (DO NOTHING) INDEPENDENT OF CLOCK
- FULLY SYNCHRONOUS WITH EDGE TRIGGERED TYPE CHARACTERISTICS ON INPUTS (EXCEPT MR)
- ASYNCHRONOUS MASTER RESET
- TYPICAL POWER DISSIPATION OF 475 mW
- TTL COMPATIBLE
- ALL CERAMIC "HERMETIC" 16-LEAD DUAL IN-LINE AND FLAT PACKAGES
- INPUT CLAMP DIODES

PIN NAMES

\bar{E}	Active LOW Enable Input
\bar{PE}	Active LOW Parallel Enable Input
P_0, P_1, P_2, P_3	Parallel Data Inputs
CP	Clock Input
\bar{MR}	Active LOW Master Reset Input
Q_0 to Q_3	Parallel Outputs (Note b)
\bar{Q}_3	Last Stage Complementary Output (Note b)
D	Serial Data Input

LOADING

(Note a)
2 U.L.
1 U.L.
1 U.L.
2 U.L.
1 U.L.
10 U.L.
10 U.L.
1 U.L.

NOTES:

- a. 1 Unit Load (U.L.) = 40 μ A HIGH/1.6 mA LOW.
 b. 10 U.L. is the output LOW drive factor and 20 U.L. is the output HIGH drive factor.

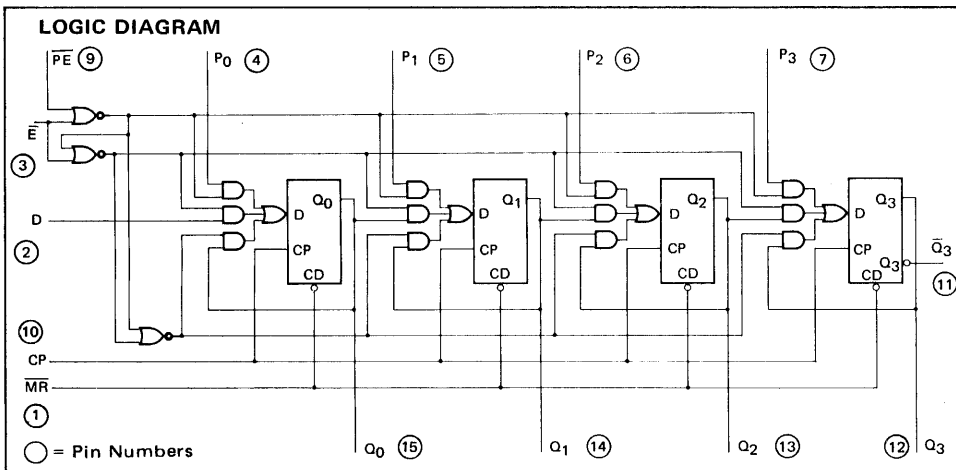

LOGIC SYMBOL

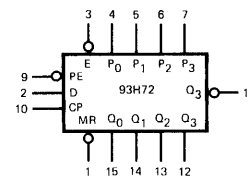

V_{CC} = Pin 16
 GND = Pin 8

CONNECTION DIAGRAMS DIP (TOP VIEW)

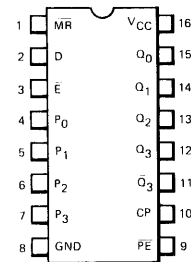

FLATPAK (TOP VIEW)

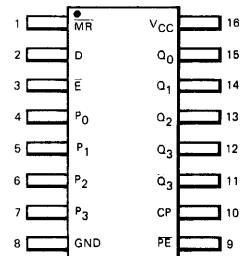

FUNCTIONAL DESCRIPTION – The 93H72 is a 4-bit shift register with three modes of operation: shift, parallel load and hold (do nothing). The register is fully synchronous with any output change occurring after the rising clock edge. The 93H72 features edge triggered type characteristics on all inputs (except \overline{MR}) which means there are no restrictions on the activity of these inputs (\overline{PE} , \overline{E} , P_0 , P_1 , P_2 , P_3 , D) for logic operation except for the set up requirements prior to the LOW to HIGH clock transition.

The mode of operation of the 93H72 is determined by the two inputs, parallel enable (\overline{PE}) and enable (\overline{E}) as shown in Table I. The active LOW enable when HIGH, places the register in the hold mode with the register flip-flops retaining their information. When the enable is activated (LOW) the parallel enable (\overline{PE}) determines whether the register operates in a shift or parallel data entry mode.

When the enable is LOW and the parallel enable input is LOW the parallel inputs are selected and will determine the next condition of the register synchronously with the clock as shown in Table II. In this mode the element appears as four common clocked D flip-flops. With \overline{E} LOW and the \overline{PE} input HIGH the device acts as a 4-bit shift register with serial data entry through the D input shown in Table III. In both cases the next state of the flip-flops occurs after the LOW to HIGH transition of the clock input.

The asynchronous active LOW master reset overrides all inputs and clears the register forcing outputs Q_0 – Q_3 LOW and \overline{Q}_3 HIGH.

To provide for left shift operation, P_3 is used as the serial data input and Q_0 is the serial data output. The other outputs are tied back to the previous parallel inputs, with Q_3 tied to P_2 , Q_2 tied to P_1 and Q_1 tied to P_0 .

TABLE I. MODE SELECTION

MODE	\overline{MR}	\overline{E}	\overline{PE}	P_0	P_1	P_2	P_3	D
Synchronous	Parallel Load	H	L	L	Parallel Data Entry			X
	Serial Shift	H	L	H	X	X	X	Serial Data Entry
	Hold	H	H	L	X	X	X	X
	Hold	H	H	H	X	X	X	X
Asynchronous	Reset	L	X	X	All Outputs Set LOW			

TABLE III. SERIAL DATA ENTRY

D INPUT AT t_n	Q_0 AT t_{n+1}
L	L
H	H

TABLE II. PARALLEL DATA ENTRY

P_0, P_1, P_2 OR P_3 INPUT AT t_n	Q at t_{n+1}
L	L
H	H

L = LOW Voltage Level
 H = HIGH Voltage Level
 X = Don't Care
 t_n = Present State
 t_{n+1} = State After Next Clock

TYPICAL INPUT AND OUTPUT CIRCUITS

INPUTS EQUIVALENT CIRCUIT

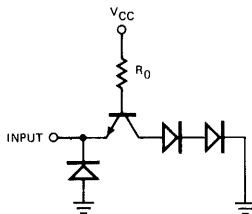

OUTPUTS EQUIVALENT CIRCUITS

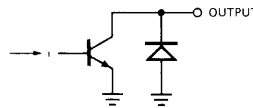

LOW

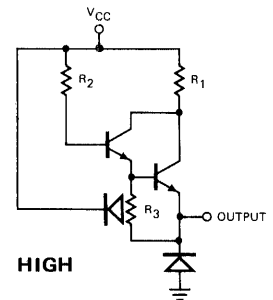

HIGH

INPUT CURRENT VERSUS INPUT VOLTAGE

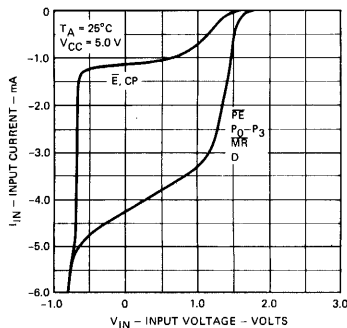

OUTPUT CURRENT VERSUS OUTPUT VOLTAGE LOW STATE

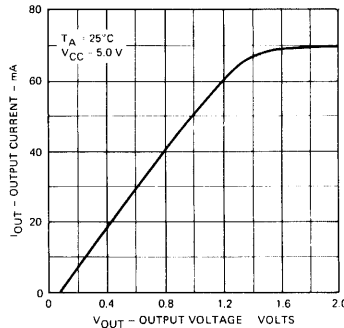

OUTPUT CURRENT VERSUS OUTPUT VOLTAGE HIGH STATE

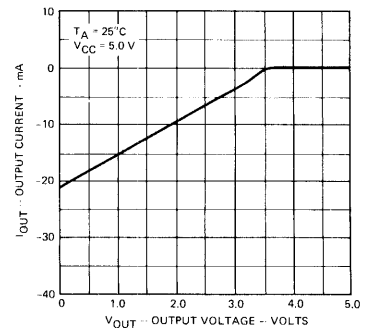

FAIRCHILD TTL/MSI • 93H72

ABSOLUTE MAXIMUM RATINGS (above which the useful life may be impaired)

Storage Temperature	-65°C to +150°C
Temperature (Ambient) Under Bias	-55°C to +125°C
V _{CC} Pin Potential to Ground Pin	-0.5 V to +7.0 V
*Input Voltage (dc)	-0.5 V to +5.5 V
*Input Current (dc)	-30 mA to +5.0 mA
Voltage Applied to Outputs (Output HIGH)	-0.5 V to +V _{CC} value
Output Current (dc) (Output LOW)	+30 mA

*Either Input Voltage Limit or Input Current is sufficient to protect the inputs.

GUARANTEED OPERATING RANGES

PART NUMBER	SUPPLY VOLTAGE (V _{CC})			TEMPERATURE
	MIN.	TYP.	MAX.	
93H72XM	4.5 V	5.0 V	5.5 V	-55°C to 125°C
93H72XC	4.75 V	5.0 V	5.25 V	0°C to 75°C

X = package type; F for Flatpak, D for Ceramic Dip, P for Plastic Dip. See Packaging Information Section for packages available on this product.

ELECTRICAL CHARACTERISTICS (Over operating temperature ranges)

SYMBOL	PARAMETER	LIMITS			UNITS	CONDITIONS
		MIN.	TYP. (Note 4)	MAX.		
V _{IH}	Input HIGH Voltage	2.0			Volts	Guaranteed Input HIGH Threshold Voltage For All Inputs
V _{IL}	Input LOW Voltage			0.8	Volts	Guaranteed Input LOW Threshold For All Inputs
V _{CD}	Input Clamp Diode Voltage			-1.5	Volts	V _{CC} = MIN., I _{IN} = -12mA, T _A = 25°C
V _{OH}	Output HIGH Voltage	2.4	2.7		Volts	V _{CC} = MIN., I _{OH} = -800 μA
V _{OL}	Output LOW Voltage		0.25	0.4	Volts	V _{CC} = MIN., I _{OL} = 16.0 mA
I _{IL}	Input Load Current \overline{MR} , D, P ₀ , P ₁ , P ₂ , P ₃ , \overline{PE}		-1.08	-1.6	mA	V _{CC} = MAX., V _{IN} = 0.4 V
I _{IL}	Input Load Current \overline{E} , CP		-2.16	-3.2	mA	V _{CC} = MAX., V _{IN} = 0.4 V
I _{IH}	Input Leakage Current \overline{MR} , D, P ₀ , P ₁ , P ₂ , P ₃ , \overline{PE}		10	40	μA	V _{CC} = MAX., V _{IN} = 2.4 V
				1.0	mA	V _{CC} = MAX., V _{IN} = 5.5 V
I _{IH}	Input Leakage Current \overline{E} , CP		20	80	μA	V _{CC} = MAX., V _{IN} = 2.4 V
				1.0	mA	V _{CC} = MAX., V _{IN} = 5.5 V
I _{CC}	Supply Current		95	120	mA	V _{CC} = MAX., 93H72XM
			100	135	mA	V _{CC} = MAX., 93H72XC
I _{SC}	Short-Circuit Output Current (Note 5)	30	75	100	mA	V _{CC} = MAX., V _{OUT} = 0.0V

NOTES:

1. The actual testing procedures used to guarantee the Electrical Characteristics are contained in a detailed Customer Sample Specification. A copy of this specification can be obtained from Fairchild Digital Product Marketing, Mountain View, California.
2. Conditions for testing, not shown in the Table, are chosen to guarantee operation under "worst case" conditions.
3. The specified LIMITS represent the "worst case" value for the parameter. Since these "worst case" values normally occur at the temperature and supply voltage extremes, additional noise immunity and guard banding can be achieved by decreasing the allowable system operating ranges.
4. Typical limits are at V_{CC} = 5.0 V, 25°C and max. loading.
5. Not more than one output should be shorted at a time.

FAIRCHILD TTL/MSI • 93H72

SWITCHING CHARACTERISTICS ($T_A = 25^\circ\text{C}$, $V_{CC} = 5.0\text{ V}$, $C_L = 15\text{ pF}$)

SYMBOL	PARAMETER	MIN.	TYP.	MAX.	UNITS	CONDITIONS
f_{sr}	Shift Right Frequency	45	60		MHz	
t_{PHL}	Turn On Delay from Positive Clock Edge to Any Output		14.5	21	ns	Fig. 1
t_{PLH}	Turn Off Delay from Positive Clock Edge to Any Output		10	16	ns	Fig. 1
$t_{PHL}(\overline{MR})$	Delay from Master Reset to Any Output		19	26	ns	Fig. 4
$t_s(\text{Data})$	Setup Time for Data (D, P ₀ , P ₁ , P ₂ , P ₃)	7.0	3.5		ns	Fig. 3
$t_s(\overline{E})$	Setup Time for Enable, \overline{E} (H or L)	17	9.0		ns	Fig. 2
$t_s(\overline{PE})$	Setup Time for Parallel Enable, \overline{PE}	19	10		ns	Fig. 1
$t_{rec}(\overline{MR})$	Recovery Time for \overline{MR}	7.0	3.0		ns	Fig. 4
$t_{pw} \overline{MR}$	Required Pulse Width for \overline{MR}	19	11		ns	Fig. 4
$t_{HOLD}(\text{Data})$ (\overline{E}) or (\overline{PE})	Hold Time for Data, \overline{E} , or \overline{PE}	0			ns	Fig. 1, 2 and 3

NOTES:

6. SET-UP TIME: t_s is defined as the minimum time required for the logic level to be present at the logic input prior to the clock transition from LOW to HIGH in order for the register to respond.
7. HOLD TIME: t_{HOLD} is defined as the minimum time following the clock transition from LOW to HIGH that the logic level must be maintained to insure continued recognition.
8. RECOVERY TIME FOR \overline{MR} : $t_{rec}(\overline{MR})$ is defined as the minimum time required between the end of the reset pulse and the clock transition from LOW to HIGH in order for the flip-flop(s) to respond to the clock.

SWITCHING TIME WAVEFORMS

The shaded areas indicate when the input is permitted to change for predictable output performance.

SET UP TIME (t_s) FOR PARALLEL ENABLE

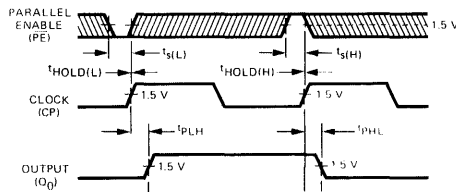

Other Conditions: $P_0 = H$
 $\overline{E} = L$
 $D = L$

Fig. 1

SET UP TIME (t_s) FOR ENABLE (\overline{E})

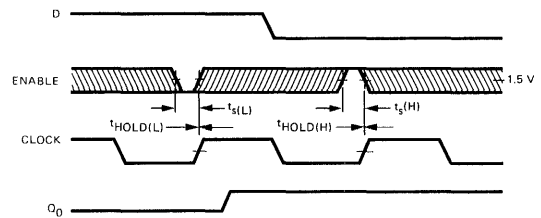

Other Conditions: $\overline{PE} = H$

Fig. 2

SET UP TIME (t_s) FOR DATA (D, P₀, 1, 2, 3)

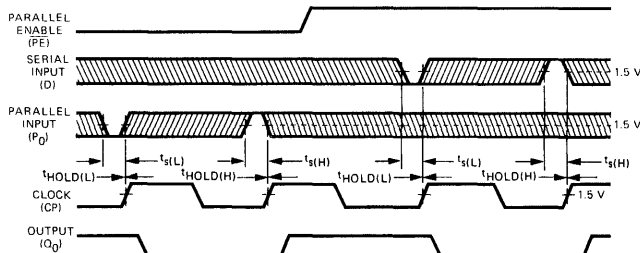

Other Conditions: $\overline{E} = L$

Fig. 3

DELAY FROM \overline{MR} TO OUTPUT t_{PHL}
MASTER RESET RECOVERY TIME (t_{rec})
REQUIRED MASTER RESET PULSE WIDTH

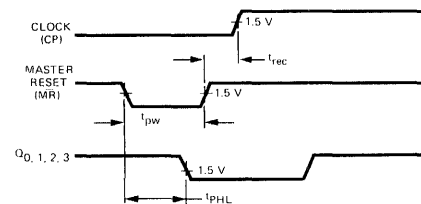

Other Conditions: $\overline{E} = L$, $\overline{PE} = L$, $P_0 = P_1 = P_2 = P_3 = H$

Fig. 4

TTL/MSI 9375/5475, 7475 9377/5477, 7477 4-BIT LATCH

DESCRIPTION — The TTL/MSI 9375/5475, 7475 and 9377/5477, 7477 are latches used as temporary storage for binary information between processing units and input/output or indicator units. Information present at a data (D) input is transferred to the Q output when the clock is HIGH and the Q output will follow the data input as long as the clock remains HIGH. When the clock goes LOW, the information (that was present at the data input at the time the transition occurred) is retained at the Q output until the clock is permitted to go HIGH.

The 9375/5475, 7475 features complementary Q and \bar{Q} output from a 4-bit latch and is available in the 16-lead packages. For higher component density applications the 9377/5477, 7477 4-bit latch is available in the 14-lead package with \bar{Q} outputs omitted.

PIN NAMES

PIN NAMES	LOADING
D ₁ , D ₂ , D ₃ , D ₄	Data Inputs 2 U.L.
\overline{CP} ₁₋₂	Clock Input Latches 1 & 2 4 U.L.
\overline{CP} ₃₋₄	Clock Input Latches 3 & 4 4 U.L.
Q ₁ , Q ₂ , Q ₃ , Q ₄	Latch Outputs 10 U.L.
\bar{Q} ₁ , \bar{Q} ₂ , \bar{Q} ₃ , \bar{Q} ₄	Complementary Latch Outputs 10 U.L.

Note: 1 Unit Load (U.L.) = 40 μ A HIGH/1.6 mA LOW

TRUTH TABLE (Each Latch)

t_n	t_{n+1}
D	Q
H	H
L	L

NOTES:

t_n = bit time before clock negative-going transition.
 t_{n+1} = bit time after clock negative-going transition.

LOGIC DIAGRAM (EACH LATCH)

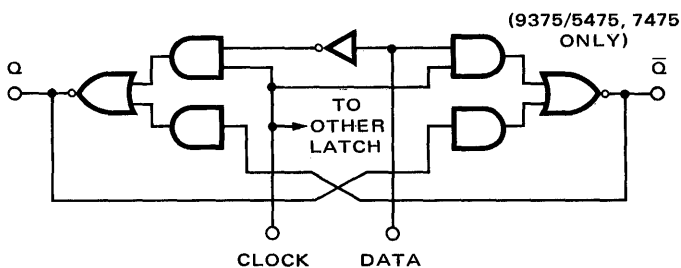

LOGIC SYMBOL

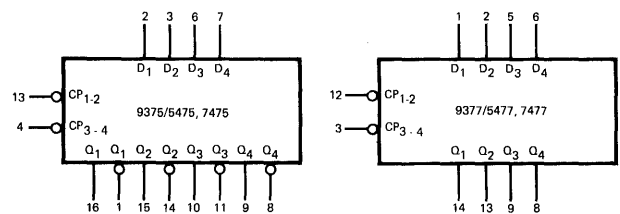

V_{CC} = Pin 5
GND = Pin 12

V_{CC} = Pin 4
GND = Pin 11
NC = Pin 7, 10

CONNECTION DIAGRAM FLATPAKS (TOP VIEW)

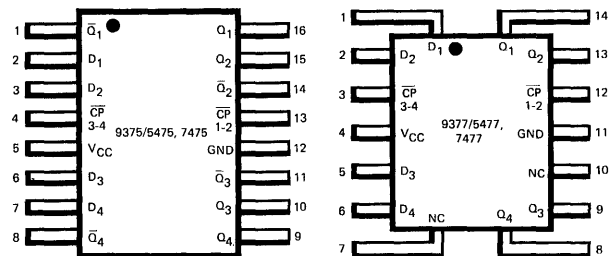

DIP (TOP VIEW)

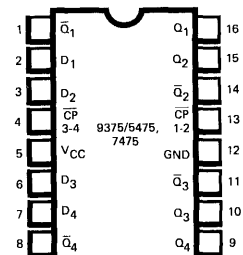

Positive logic: See truth table.
NC — No internal connection.

TTL/MSI • 9375/5475, 7475 • 9377/5477, 7477

ABSOLUTE MAXIMUM RATINGS (above which the useful life may be impaired)

Storage Temperature	-65°C to +150°C
Temperature (Ambient) Under Bias	-55°C to +125°C
V _{CC} Pin Potential to Ground Pin	-0.5V to +7.0 V
*Input Voltage (dc)	-0.5V to +5.5 V
*Input Current (dc)	-30 mA to +5.0 mA
Voltage Applied to Outputs (Output HIGH)	-0.5 V to +V _{CC} value
Output Current (dc) (Output LOW)	+30 mA

*Either Input Voltage limit or Input Current limit is sufficient to protect the inputs.

RECOMMENDED OPERATING CONDITIONS

PARAMETER	9375XM/5475XM 9377XM/5477XM			9375XC/7475XC 9377XC/7477XC			UNITS
	MIN.	TYP.	MAX.	MIN.	TYP.	MAX.	
Supply Voltage V _{CC} (See Note 4)	4.5	5.0	5.5	4.75	5.0	5.25	Volts
Operating Free-Air Temperature Range	-55	25	125	0	25	70	°C
Normalized Fan Out from Outputs			10			10	

X = package type; F for Flatpak, D for Ceramic Dip, P for Plastic Dip. See Packaging Information Section for packages available on this product.

ELECTRICAL CHARACTERISTICS OVER OPERATING TEMPERATURE RANGE (Unless Otherwise Noted)

SYMBOL	PARAMETER	LIMITS			UNITS	TEST CONDITIONS (Note 1)	TEST FIGURE
		MIN.	TYP. (Note 2)	MAX.			
V _{IH}	Input HIGH Voltage	2.0			Volts	Guaranteed Input HIGH Voltage	1
V _{IL}	Input LOW Voltage			0.8	Volts	Guaranteed Input LOW Voltage	2
V _{OH}	Output HIGH Voltage	2.4			Volts	V _{CC} = MIN., I _{OH} = -0.4 mA	1 & 2
V _{OL}	Output LOW Voltage			0.4	Volts	V _{CC} = MIN., I _{OL} = 16 mA	1 & 2
I _{IH}	Input HIGH Current at D			90	μA	V _{CC} = MAX., V _{IN} = 2.4 V	3
				1.0	mA	V _{CC} = MAX., V _{IN} = 5.5 V	
I _{IL}	Input HIGH Current at Clock			160	μA	V _{CC} = MAX., V _{IN} = 2.4 V	3
				1.0	mA	V _{CC} = MAX., V _{IN} = 5.5 V	
I _{IOL}	Input LOW Current at D			-3.2	mA	V _{CC} = MAX., V _{IN} = 0.4 V	3
				-6.4	mA	V _{CC} = MAX.	
I _{OS}	Output Short Circuit Current (Note 3)	-20		-57	mA	9375/5475; 9377/5477	V _{CC} = MAX. 4
		-18		-57	mA	9375/7475; 9377/7477	
I _{CC}	Supply Current		32	46	mA	9375/5475; 9377/5477	V _{CC} = MAX. 5
			32	53	mA	9375/7475; 9377/7477	

SWITCHING CHARACTERISTICS (T_A = 25°C)

SYMBOL	PARAMETER	LIMITS			UNITS	TEST CONDITIONS	TEST FIGURE
		MIN.	TYP.	MAX.			
t _{setupH}	At D Input		7.0	20	ns	V _{CC} = 5.0 V C _L = 15 pF R _L = 400Ω	A
t _{setupL}	At D Input		14	20	ns		A
t _{holdH}	At D Input	0	15*		ns		A
t _{holdL}	At D Input	0	6.0*		ns		A
t _{PLH}	D to Q		16	30	ns	V _{CC} = 5.0 V, C _L = 15 pF	A
t _{PHL}			14	25		R _L = 400Ω	
t _{PLH}	D to Q̄ (9375/5475, 7475)		24	40	ns	V _{CC} = 5.0 V, C _L = 15 pF	A
t _{PHL}			7.0	15		R _L = 400Ω	
t _{PLH}	C̄P to Q̄		16	30	ns	V _{CC} = 5.0 V, C _L = 15 pF	A
t _{PHL}			7.0	15		R _L = 400Ω	
t _{PLH}	C̄P to Q (9375/5475, 7475)		16	30	ns	V _{CC} = 5.0 V, C _L = 15 pF	A
t _{PHL}			7.0	15		R _L = 400Ω	

NOTES:

- (1) For conditions shown as MIN. or MAX., use the appropriate value specified under recommended operating conditions for the applicable device type.
 - (2) Typical limits are at V_{CC} = 5.0 V, 25°C.
 - (3) Not more than one output should be shorted at a time.
 - (4) These voltage values are with respect to network ground terminal.
- * These typical times indicate that period occurring prior to the fall of clock pulse (t_Q) below 1.5 V when data at the D input will still be recognized at stored.

PARAMETER MEASUREMENT INFORMATION

DC TEST CIRCUITS*

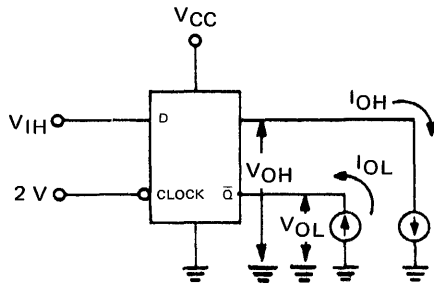

1. Each latch is tested separately.

Fig. 1

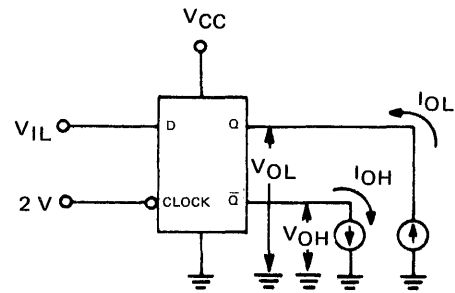

1. Each latch is tested separately.

Fig. 2

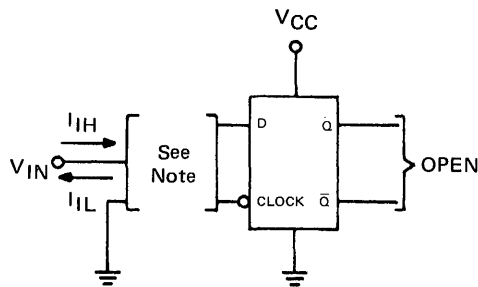

1. Each input is tested separately.
2. When testing I_{IH} at D ground clock.
3. When testing I_{IH} at clock ground all D inputs.

Fig. 3

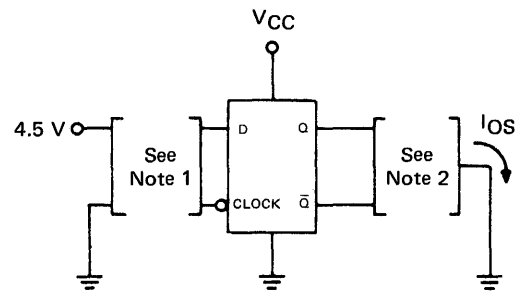

1. Input conditions are in accordance with truth table.
2. Each latch and each output is tested separately.

Fig. 4

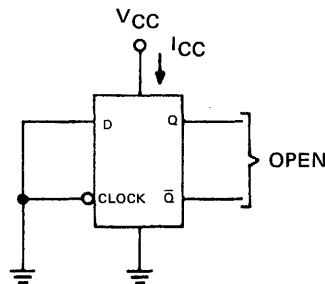

1. All latches are tested simultaneously.

Fig. 5

*Arrows indicate actual direction of current flow. Complementary \bar{Q} outputs are available on the 9375/5475, 7475.

PARAMETER MEASUREMENT INFORMATION (con't)

SWITCHING CHARACTERISTICS*

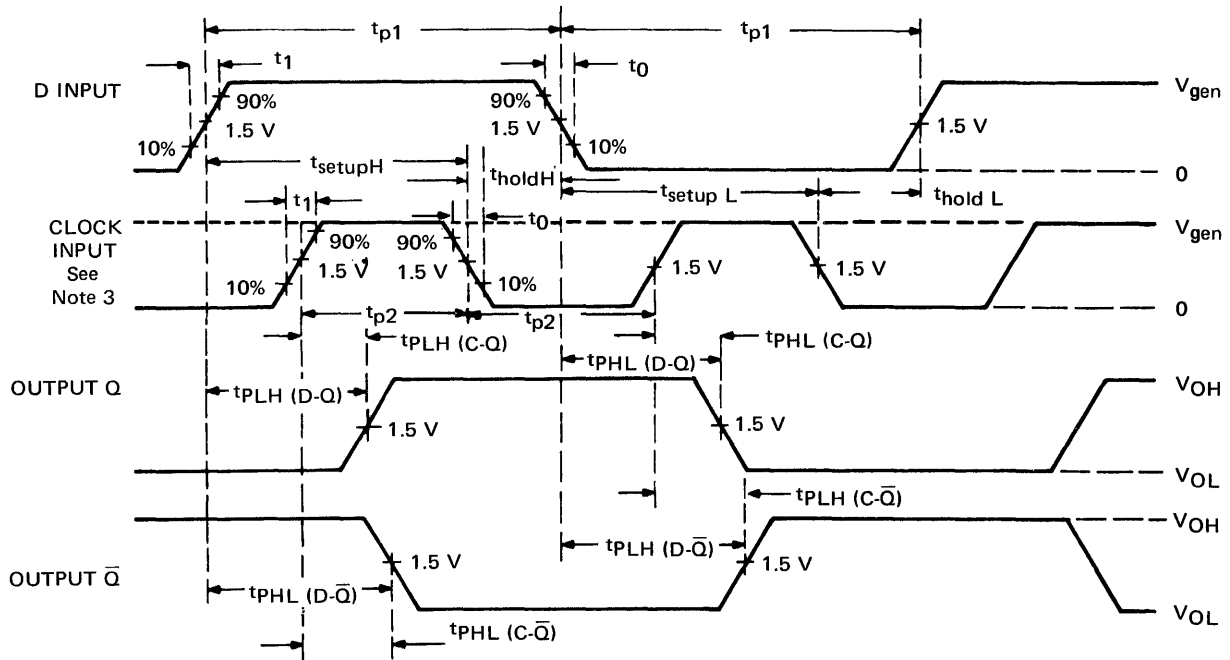
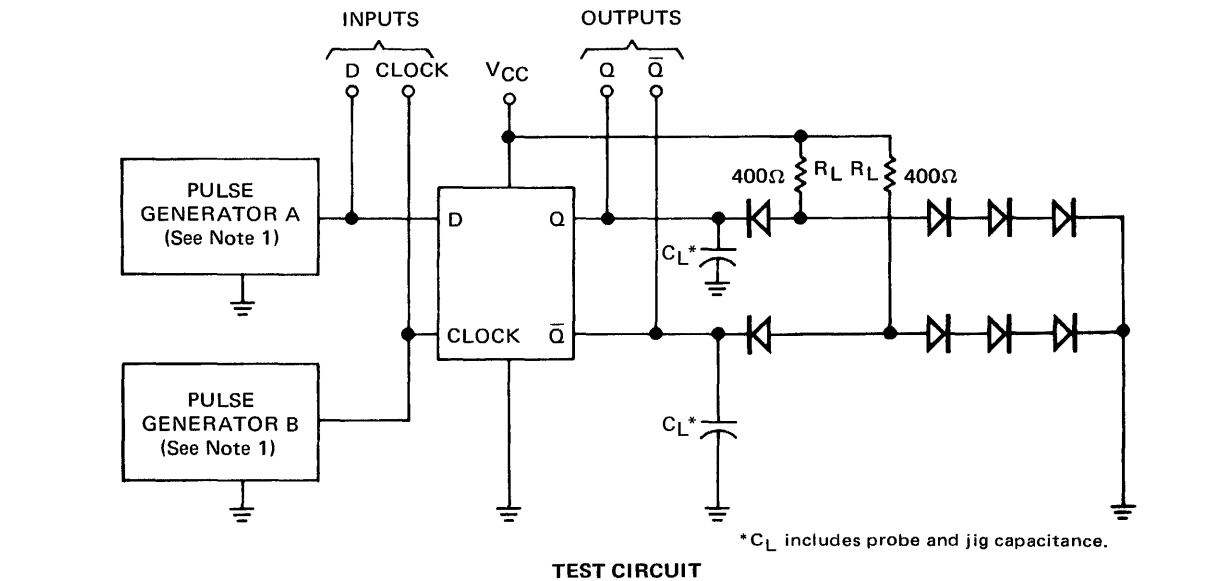

- NOTES:
1. The pulse generators have the following characteristics: $V_{gen} = 3\text{ V}$, $t_1 = t_0 \leq 10\text{ ns}$, and $Z_{out} \approx 50\Omega$. For pulse generator A $t_{p1} = 1\text{ }\mu\text{s}$ and PRR = 500 kHz. For pulse generator B, $t_{p2} = 500\text{ ns}$ and PRR = 1 MHz. Positions of D-input and clock-input pulses are varied with respect to each other to verify setup and hold times.
 2. Each latch is tested separately.
 3. When measuring $t_{PLH} (D-Q)$ and $t_{PHL} (D-Q)$ or $t_{PHL} (D-Q)$ and $t_{PLH} (D-\bar{Q})$ for the 9375/5475, 7475, clock input must be held at high level.

Fig. A SWITCHING TIMES

*Complementary Q outputs are on the 9375/5475, 7475.

TTL/MSI 9380/5480, 7480

GATED FULL ADDER

DESCRIPTION – The TTL/MSI 9380/5480, 7480 is a single-bit, high speed, Binary Full Adder with gated complementary inputs, complementary sum (Σ and $\bar{\Sigma}$) outputs and inverted carry output. It is designed for medium and high speed, multiple-bit, parallel-add/serial-carry applications. The circuit utilizes DTL for the gated inputs and high speed, high fan out TTL for the sum and carry outputs. The circuit is entirely compatible with both DTL and TTL logic families. The implementation of a single-inversion, high speed, Darlington-connected serial-carry circuit minimizes the necessity for extensive "lookahead" and carry-cascading circuits.

PIN NAMES

A_1, A_2, B_1, B_2
 A^*, B^*
 A_C, B_C
 C_n
 C_{n+1}
 $\Sigma, \bar{\Sigma}$
 A^*, B^*

Non Inverting Data Inputs
 Inverting Data Inputs
 Control Inputs
 Carry Input
 Carry Output
 Sum Outputs
 When Used as Outputs

LOADING

1 U.L.
 1.65 U.L.
 1 U.L.
 5 U.L.
 5 U.L.
 10 U.L.
 3 U.L.

1 Unit Load (U.L.) = 40 μ A HIGH/1.6mA LOW.

TRUTH TABLE

C_n	B	A	\bar{C}_{n+1}	$\bar{\Sigma}$	Σ
L	L	L	H	H	L
L	L	H	H	L	H
L	H	L	H	L	H
L	H	H	L	H	L
H	L	L	H	L	H
H	L	H	L	H	L
H	H	L	L	H	L
H	H	H	L	L	H

NOTES:

- $A = \bar{A}^* \cdot A_C, B = \bar{B}^* \cdot B_C$ where $A^* = \bar{A}_1 \cdot \bar{A}_2$
 $B^* = \bar{B}_1 \cdot \bar{B}_2$
- When A^* or B^* are used as inputs, A_1 and A_2 or B_1 and B_2 respectively must be connected to GND.
- When A_1 and A_2 or B_1 and B_2 are used as inputs, A^* or B^* respectively must be open or used to perform Dot-OR logic.

LOGIC SYMBOL

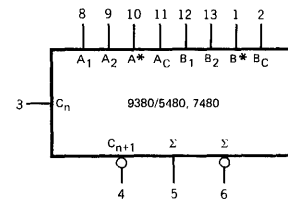

CONNECTION DIAGRAM DIP (TOP VIEW)

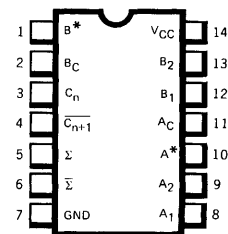

FLATPAK (TOP VIEW)

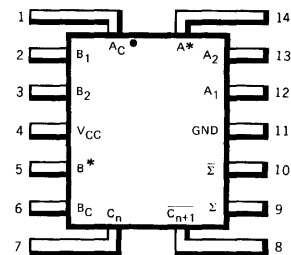

Positive logic: See truth table

LOGIC DIAGRAM

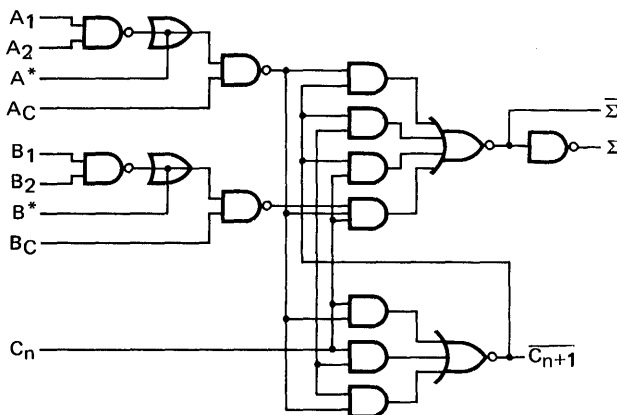

TTL/MSI • 9380/5480, 7480

ABSOLUTE MAXIMUM RATINGS (above which the useful life may be impaired)

Storage Temperature	-65°C to +150°C
Temperature (Ambient) Under Bias	-55°C to +125°C
V _{CC} Pin Potential to Ground Pin	-0.5 V to +7.0 V
*Input Voltage (dc)	-0.5 V to +5.5 V
*Input Current (dc)	-30 mA to +5.0 mA
Voltage Applied to Outputs (Output HIGH)	-0.5 V to +V _{CC} value
Output Current (dc) (Output LOW)	+30 mA

*Either Input Voltage limit or Input Current limit is sufficient to protect the inputs.

RECOMMENDED OPERATING CONDITIONS

PARAMETER	9380XM/5480XM			9380XC/7480XC			UNITS
	MIN.	TYP.	MAX.	MIN.	TYP.	MAX.	
Supply Voltage V _{CC}	4.5	5.0	5.5	4.75	5.0	5.25	Volts
Operating Free-Air Temperature Range	-55	25	125	0	25	70	°C
Normalized Fan Out from Outputs	C _{n+1} , N		5.0			5.0	
	Σ or Σ̄, N		10			10	
	A* or B*, N		3.0			3.0	

X = package type; F for Flatpak, D for Ceramic Dip, P for Plastic Dip. See Packaging Information Section for packages available on this product.

ELECTRICAL CHARACTERISTICS OVER OPERATING TEMPERATURE RANGE (Unless Otherwise Noted)

SYMBOL	PARAMETER	LIMITS			UNITS	TEST CONDITIONS (Note 1)	TEST FIGURE
		MIN.	TYP. (Note 2)	MAX.			
V _{IH}	Input HIGH Voltage	2.0			Volts	Guaranteed V _{IH}	1 & 2
V _{IL}	Input LOW Voltage			0.8	Volts	Guaranteed V _{IL}	1 & 2
V _{OH}	Output HIGH Voltage	2.4	3.5		Volts	V _{CC} = MIN.	2
V _{OL}	Output LOW Voltage		0.22	0.4	Volts	V _{CC} = MIN., I _{OL} = 16 mA	1
I _{IH}	Input HIGH Current at A ₁ , A ₂ , B ₁ , B ₂ , A _C or B _C			15	μA	V _{CC} = MAX., V _{IN} = 2.4 V	5
				1.0	mA	V _{CC} = MAX., V _{IN} = 5.5 V	
	Input HIGH Current at C _n			200	μA	V _{CC} = MAX., V _{IN} = 2.4 V	6
I _{IL}	Input LOW Current at A ₁ , A ₂ , B ₁ , B ₂ , A _C , or B _C			-1.6	mA	V _{CC} = MAX., V _{IN} = 0.4 V	3
				-2.6	mA	V _{CC} = MAX., V _{IN} = 0.4 V	4
	Input LOW Current at C _n			-8.0	mA	V _{CC} = MAX., V _{IN} = 0.4 V	4
I _{OS}	Output Short Circuit Current at Σ or Σ̄ (Note 3)	-20		-57	mA	9380/5480	V _{CC} = MAX. 7
		-18		-57	mA	9380/7480	
	Output Short Circuit Current at C _{n+1} (Note 3)	-20		-70	mA	9380/5480	V _{CC} = MAX. 7
		-18		-70	mA	9380/7480	
I _{CC}	Supply Current		21	31	mA	9380/5480	V _{CC} = MAX. 8
			21	35	mA	9380/7480	

NOTES:

- (1) For conditions shown as MIN. or MAX., use the appropriate value specified under recommended operating conditions for the applicable device type.
- (2) Typical limits are at V_{CC} = 5.0 V, 25°C.
- (3) Not more than one output should be shorted at a time.

SWITCHING CHARACTERISTICS (T_A = 25°C)

SYMBOL	PARAMETER	LIMITS			UNITS	TEST CONDITIONS	FIGURE A TEST NO.
		MIN.	TYP.	MAX.			
t _{PLH}	(C _n to $\overline{C_{n+1}}$)		13	17	ns	V _{CC} = 5.0 V C _L = 15 pF R _L = 780Ω	1
t _{PHL}	(C _n to $\overline{C_{n+1}}$)		8.0	12			2
t _{PLH}	(B _c to $\overline{C_{n+1}}$)		18	25	ns		3
t _{PHL}	(B _c to $\overline{C_{n+1}}$)		38	55			4
t _{PLH}	(A _c to Σ)		52	70	ns	V _{CC} = 5.0 V C _L = 15 pF R _L = 400Ω	5
t _{PHL}	(A _c to Σ)		62	80			6
t _{PLH}	(B _c to Σ)		38	55	ns		7
t _{PHL}	(B _c to Σ)		56	75			8
t _{PLH}	(A ₁ to A*)		48	65	ns	V _{CC} = 5.0 V C _L = 15 pF	9
t _{PHL}	(A ₁ to A*)		17	25			10
t _{PLH}	(B ₁ to B*)		48	65	ns		11
t _{PHL}	(B ₁ to B*)		17	25			12

PARAMETER MEASUREMENT INFORMATION

DC TEST CIRCUITS*

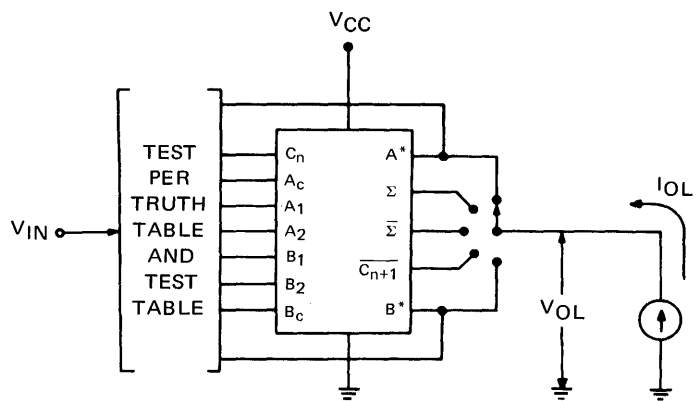

TEST TABLE

Output Under Test	I _{OL} (Min)
Σ or Σ̄	16 mA
$\overline{C_{n+1}}$	8 mA
A* or B*	4.8 mA

1. Each input or output is tested separately.
2. When A* is tested A₁ and A₂ are at GND. When B* is tested B₁ and B₂ are at GND.
3. When A₁ and A₂ or B₁ and B₂ is tested, A* or B* respectively, is open.

Fig. 1

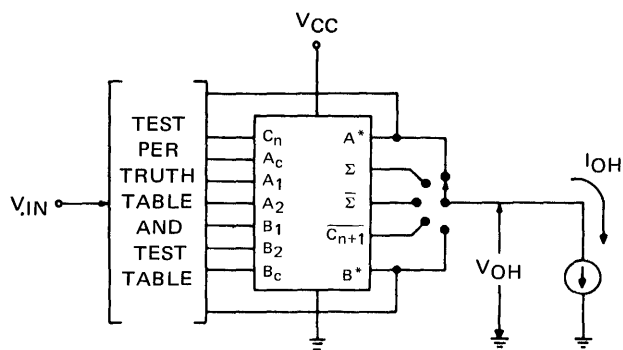

TEST TABLE

Output Under Test	I _{OH} (Min)
Σ or Σ̄	-400 μA
$\overline{C_{n+1}}$	-200 μA
A* or B*	-120 μA

1. Each input or output is tested separately.
2. When A* is tested A₁ and A₂ are at GND. When B* is tested B₁ and B₂ are at GND.
3. When A₁ and A₂ or B₁ and B₂ are tested A or B, respectively, is open.

Fig. 2

* Arrows indicate actual direction of current flow.

PARAMETER MEASUREMENT INFORMATION

DC TEST CIRCUITS* (continued)

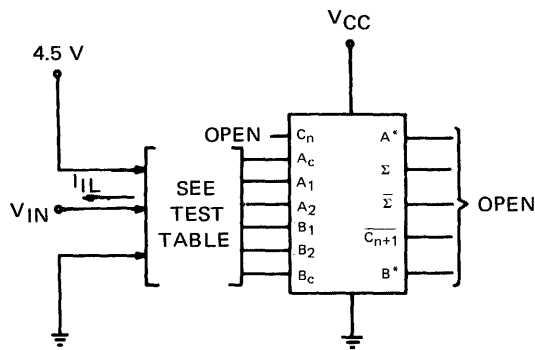

TEST TABLE

Apply V_{IN} (Test I_{IL})	Apply 4.5 V	GND
A_1	A_2	None
A_2	A_1	None
B_1	B_2	None
B_2	B_1	None
A_c	None	A_1 and A_2
B_c	None	B_1 and B_2

1. Each input is tested separately.

Fig. 3

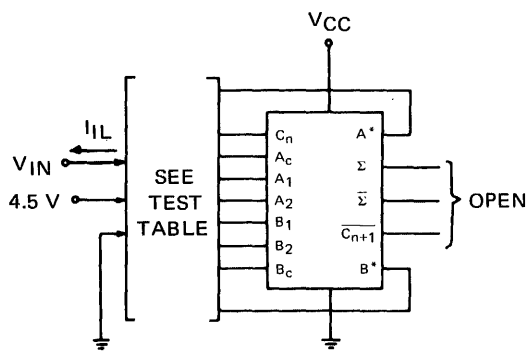

TEST TABLE

Apply V_{IN} (Test I_{IL})	Apply 4.5 V	GND
A^*	A_c	A_1 and A_2
B^*	B_c	B_1 and B_2
C_n	None	None

Unused inputs are open.

1. Each input is tested separately.

Fig. 4

*Arrows indicate actual direction of current flow.

PARAMETER MEASUREMENT INFORMATION

DC TEST CIRCUITS* (continued)

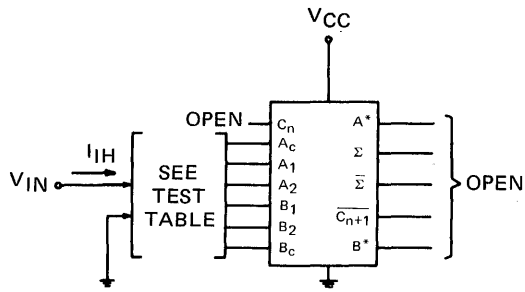

TEST TABLE

Apply V_{IN} (Test I_{IH})	GND
A ₁	A ₂
A ₂	A ₁
B ₁	B ₂
B ₂	B ₁
A _c	A*
B _c	B*

1. Each input is tested separately.

Fig. 5

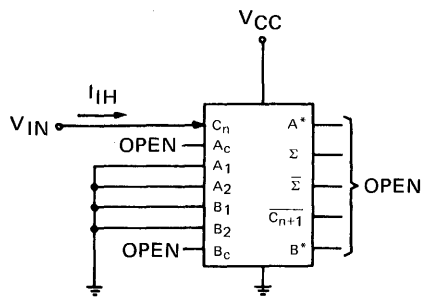
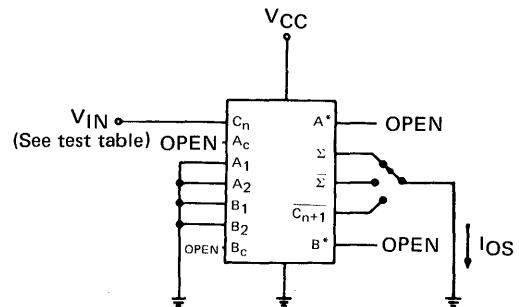

Fig. 6



1. Each output is tested separately.

TEST TABLE

Output Under Test	V_{IN} Value
Σ	V_{CC}
$\bar{\Sigma}$ or $\overline{C_{n+1}}$	GND

Fig. 7

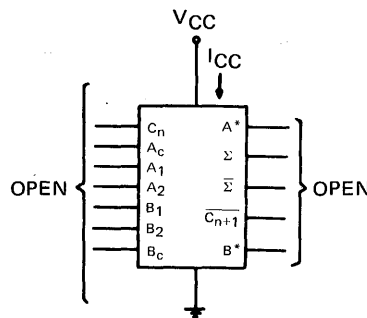
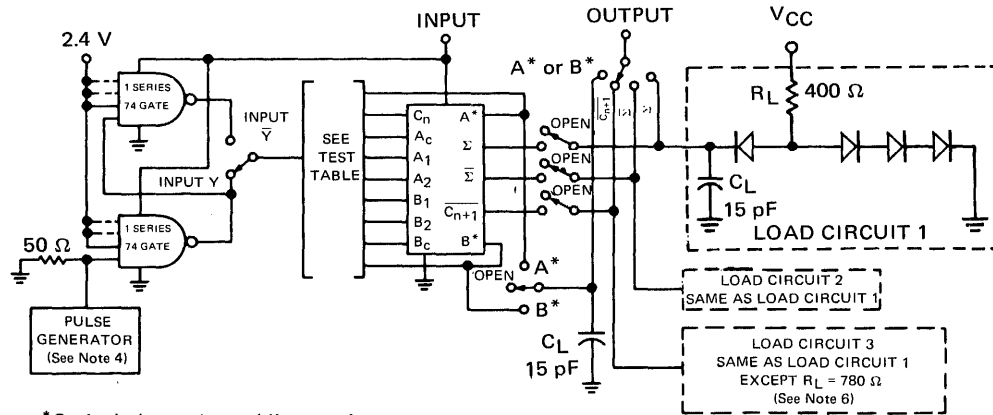

Fig. 8

* Arrows indicate actual direction of current flow.

PARAMETER MEASUREMENT INFORMATION

SWITCHING CHARACTERISTICS



* C_L includes probe and jig capacitance.

NOTES:

1. Perform test in accordance with test table.
2. Each output is tested separately.
3. Voltage values are with respect to network GND terminal.
4. The generator has the following characteristics: $V_{gen} = 3 V, t_1 = t_0 \leq 15 ns, t_p = 0.5 \mu s, PRR = 1 MHz,$ and $Z_{out} \approx 50 \Omega$.
5. Inputs and outputs not otherwise specified are open.
6. Load circuit 2 simulates output load of 5.

TEST CIRCUIT

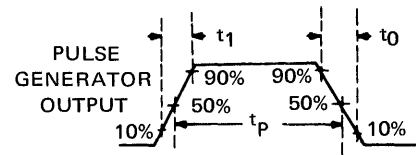

TEST TABLE (SEE NOTE 5)

TEST NO.	OUTPUT UNDER TEST	APPLY INPUT \bar{Y} TO	APPLY INPUT Y TO	APPLY +2.4 V TO	APPLY GND TO	APPLY OUTPUT LOADING TO
1	\bar{C}_{n+1}	None	C_n	None	B_1	\bar{C}_{n+1} (N = 5)
2	\bar{C}_{n+1}	None	C_n	None	B_1	\bar{C}_{n+1} (N = 5)
3	\bar{C}_{n+1}	B_c	None	C_n	A_1, B_1	\bar{C}_{n+1} (N = 5)
4	\bar{C}_{n+1}	B_c	None	C_n	A_1, B_1	\bar{C}_{n+1} (N = 5)
5	Σ	A_c	None	C_n	A_1, B_1	Σ (N = 10)
						Σ (N = 10)
						\bar{C}_{n+1} (N = 5)
6	Σ	A_c	None	C_n	A_1, B_1	Σ (N = 10)
						$\bar{\Sigma}$ (N = 10)
						\bar{C}_{n+1} (N = 5)
7	$\bar{\Sigma}$	B_c	None	C_n	B_1	$\bar{\Sigma}$ (N = 10)
8	$\bar{\Sigma}$	B_c	None	C_n	B_1	$\bar{\Sigma}$ (N = 10)
9	A^*	None	A_1	A_2	None	A^* ($C_L = 15 pF$)
10	A^*	None	A_1	A_2	None	A^* ($C_L = 15 pF$)
11	B^*	None	B_1	B_2	None	B^* ($C_L = 15 pF$)
12	B^*	None	B_1	B_2	None	B^* ($C_L = 15 pF$)

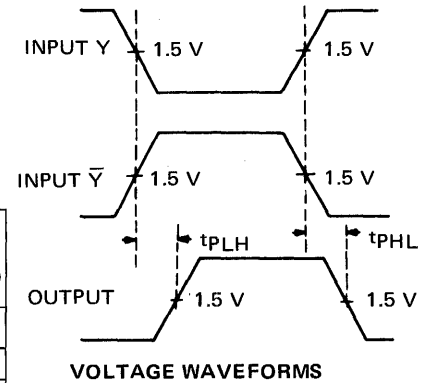

Fig. A – SWITCHING TIMES

TTL/MSI 9382/5482, 7482

2-BIT FULL ADDER

DESCRIPTION – The TTL/MSI 9382/5482,7482 is a Full Adder which performs the addition of two 2-bit binary numbers. The sum (Σ) outputs are provided for each bit and the resultant carry (C_2) is obtained from the second bit. Designed for medium to high speed, multiple-bit, parallel-add/serial-carry applications, the circuit utilized high speed, high fan out TTL. The implementation of a single-inversion, high speed, Darlington-connected serial-carry circuit within each bit minimizes the necessity for extensive "lookahead" and carry-cascading circuits.

PIN NAMES

A_1, B_1	Data Inputs	4 U.L.
A_2, B_2	Data Inputs	1 U.L.
C_{IN}	Carry Input	4 U.L.
Σ_1	Sum Output Bit 1	10 U.L.
Σ_2	Sum Output Bit 2	10 U.L.
C_2	Carry Output Bit 2	5 U.L.

LOADING

4 U.L.
1 U.L.
4 U.L.
10 U.L.
10 U.L.
5 U.L.

1 Unit Load (U.L.) = 40 μ A HIGH/1.6 mA LOW

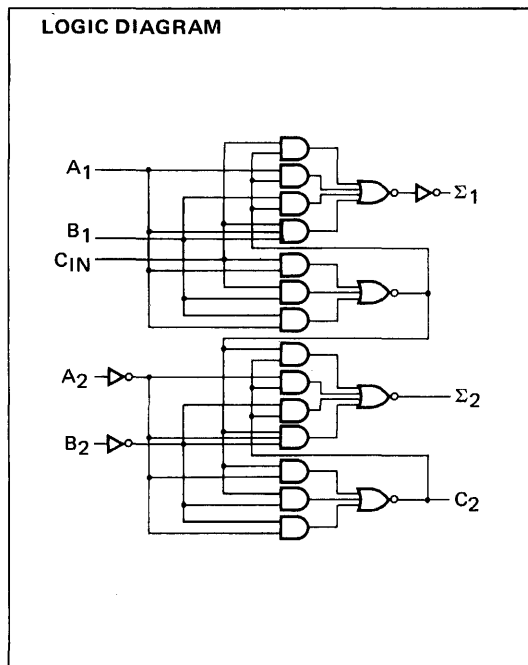

TRUTH TABLE

INPUT				OUTPUT						
A_1	B_1	A_2	B_2	WHEN $C_{IN} = 0$			WHEN $C_{IN} = 1$			
				Σ_1	Σ_2	C_2	Σ_1	Σ_2	C_2	
L	L	L	L	L	L	L	H	L	L	
H	L	L	L	H	L	L	L	H	L	
L	H	L	L	H	L	L	L	H	L	
H	H	L	L	L	H	L	H	H	L	
L	L	H	L	L	H	L	H	H	L	
H	L	H	L	H	H	L	L	L	H	
L	H	H	L	H	H	L	L	L	H	
H	H	H	L	L	L	H	H	L	H	
L	L	L	H	L	H	L	H	H	L	
H	L	L	H	H	H	L	L	L	H	
L	H	L	H	H	H	L	L	L	H	
H	H	L	H	L	L	H	H	L	H	
L	L	H	H	L	L	H	H	L	H	
H	L	H	H	H	L	H	L	H	H	
L	H	H	H	H	L	H	L	H	H	
H	H	H	H	L	H	H	H	H	H	

LOGIC SYMBOL

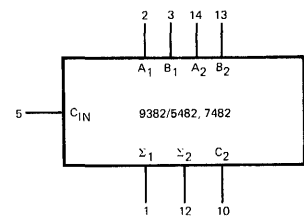

V_{CC} = Pin 4
 GND = Pin 11
 NC = Pin 6, 7, 8, 9

CONNECTION DIAGRAM DIP (TOP VIEW)

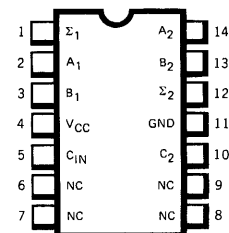

FLATPAK (TOP VIEW)

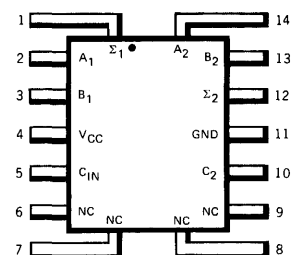

Positive logic: See truth table
 NC – No internal connection

ABSOLUTE MAXIMUM RATINGS (above which the useful life may be impaired)

Storage Temperature	-65°C to +150°C
Temperature (Ambient) Under Bias	-55°C to +125°C
V _{CC} Pin Potential to Ground Pin	-0.5 V to +7.0 V
*Input Voltage (dc)	-0.5 V to +5.5 V
*Input Current (dc)	-30 mA to +5.0 mA
Voltage Applied to Outputs (Output HIGH)	-0.5 V to +V _{CC} value
Output Current (dc) (Output LOW)	+30 mA

*Either Input Voltage limit or Input Current limit is sufficient to protect the inputs.

RECOMMENDED OPERATING CONDITIONS

PARAMETER	9382XM/5482XM			9382XC/7482XC			UNITS
	MIN.	TYP.	MAX.	MIN.	TYP.	MAX.	
Supply Voltage V _{CC} (See Note 4)	4.5	5.0	5.5	4.75	5.0	5.25	Volts
Operating Free-Air Temperature Range	-55	25	125	0	25	70	°C
Normalized Fan Out from Output	C ₂		5.0			5.0	
	Σ ₁ or Σ ₂		10			10	

X = package type; F for Flatpak, D for Ceramic Dip, P for Plastic Dip. See Packaging Information Section for packages available on this product.

ELECTRICAL CHARACTERISTICS OVER OPERATING TEMPERATURE RANGE (Unless Otherwise Noted)

SYMBOL	PARAMETER	LIMITS			UNITS	TEST CONDITIONS (Note 1)	TEST FIGURE
		MIN.	TYP. (Note 2)	MAX.			
V _{IH}	Input HIGH Voltage	2.0			Volts	Guaranteed V _{IH}	1 & 2
V _{IL}	Input LOW Voltage			0.8	Volts	Guaranteed V _{IL}	1 & 2
V _{OH}	Output HIGH Voltage	2.4			Volts	V _{CC} = MIN., I _{OH} = -400 μA	2
V _{OL}	Output LOW Voltage			0.4	Volts	V _{CC} = MIN., I _{OL} = 16 mA	1
I _{IH}	Input HIGH Current at A ₁ , B ₁ or C _{1N}			160	μA	V _{CC} = MAX., V _{IN} = 2.4 V	3
				1.0	mA	V _{CC} = MAX., V _{IN} = 5.5 V	
	Input HIGH Current at A ₂ or B ₂			40	μA	V _{CC} = MAX., V _{IN} = 2.4 V	3
			1.0	mA	V _{CC} = MAX., V _{IN} = 5.5 V		
I _{IL}	Input LOW Current at A ₁ , B ₁ or C _{1N}			-6.4	mA	V _{CC} = MAX., V _{IN} = 0.4 V	3
	Input LOW Current at A ₂ or B ₂			-1.6	mA	V _{CC} = MAX., V _{IN} = 0.4 V	3
I _{OS}	Output Short Circuit Current at Σ ₁ or Σ ₂ (Note 3)	-20		-55	mA	9382/5482	V _{CC} = MAX. 4
		-18		-55	mA	9382/7482	
	Output Short Circuit Current at C ₂ (Note 3)	-20		-70	mA	9382/5482	V _{CC} = MAX. 4
		-18		-70	mA	9382/7482	
I _{CC}	Supply Current		35	50	mA	9382/5482	V _{CC} = MAX. 3
			35	58	mA	9382/7482	

SWITCHING CHARACTERISTICS (T_A = 25°C)

SYMBOL	PARAMETER	LIMITS			UNITS	TEST CONDITIONS	FIGURE A TEST NO.	
		MIN.	TYP.	MAX.				
t _{PLH}	C _{1N} to Σ ₁			34	ns	V _{CC} = 5.0 V C _L = 15 pF R _L = 400Ω	1	
t _{PHL}				40			2	
t _{PLH}	B ₂ to Σ ₂			40	ns		3	
t _{PHL}				35			4	
t _{PLH}	C _{1N} to Σ ₂			38	ns		5	
t _{PHL}				42			6	
t _{PLH}	C _{1N} to C ₂		17	27	ns		V _{CC} = 5.0 V C _L = 15 pF R _L = 780Ω	7
t _{PHL}			12	19			8	

NOTES:

- (1) For conditions shown as MIN. or MAX., use the appropriate value specified under recommended operating conditions for the applicable device type.
- (2) Typical limits are at V_{CC} = 5.0 V, 25°C.
- (3) Not more than one output should be shorted at a time.
- (4) These voltage values are with respect to network ground terminal.

PARAMETER MEASUREMENT INFORMATION

DC TEST CIRCUITS*

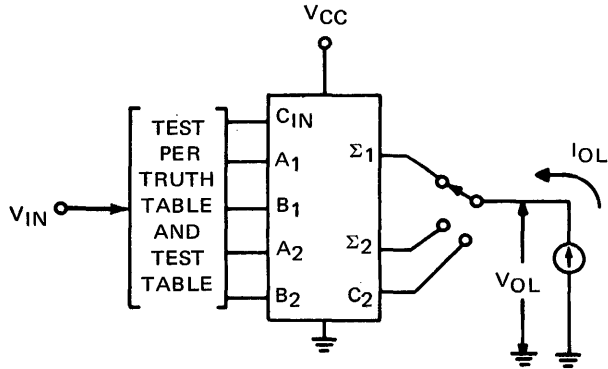

1. Each input or output is tested separately.

TEST TABLE

OUTPUT UNDER TEST	I _{OL}
Σ ₁ or Σ ₂	16 mA
C ₂	8 mA

Fig. 1

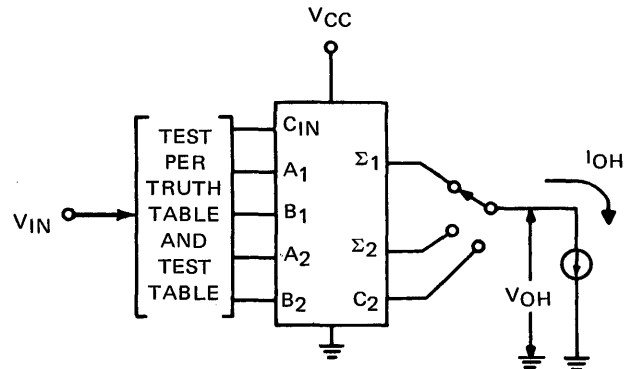

1. Each input or output is tested separately.

TEST TABLE

OUTPUT UNDER TEST	I _{OH}
Σ ₁ or Σ ₂	-400 μA
C ₂	-200 μA

Fig. 2

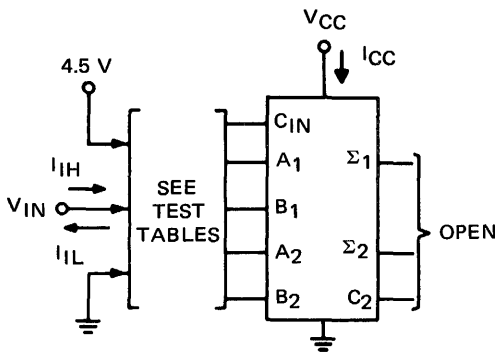

1. Each input is tested separately.
2. When testing I_{CC} apply 4.5 V to A₁, A₂, and C_{1N}; and ground B₁ and B₂.

Fig. 3

I_{IL} TEST TABLE

APPLY V _{IN} TEST I _{IN}	APPLY 4.5 V
C _{1N}	A ₁ and B ₁
A ₁	C _{1N} and B ₁
B ₁	C _{1N} and A ₁
A ₂	None
B ₂	None

I_{IH} TEST TABLE

APPLY V _{IN} TEST I _{IN}	GND
C _{1N}	A ₁ and B ₁
A ₁	C _{1N} and B ₁
B ₁	C _{1N} and A ₁
A ₂	None
B ₂	None

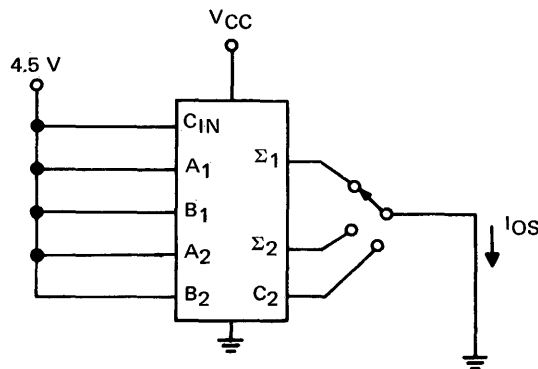

1. Each output is tested separately.

Fig. 4

*Arrows indicate actual direction of current flow.

PARAMETER MEASUREMENT INFORMATION

SWITCHING CHARACTERISTICS

TEST CIRCUIT

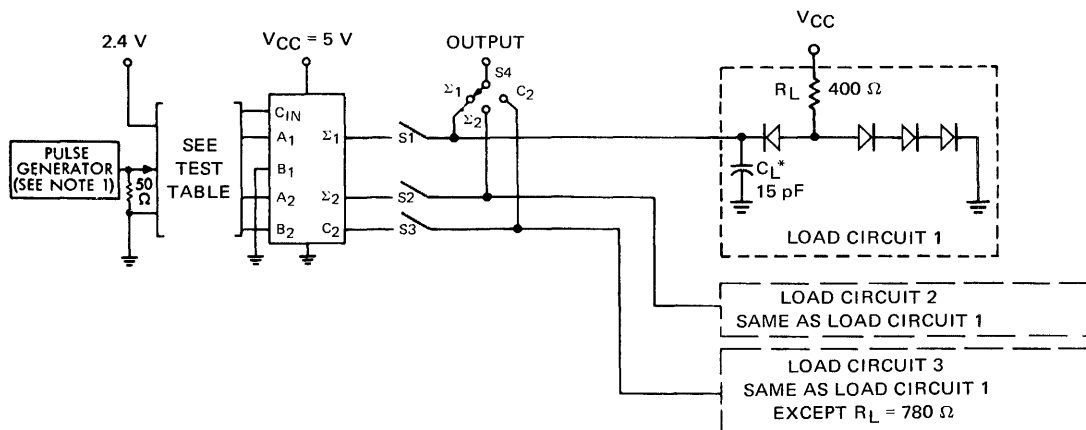

*C_L includes probe and jig capacitance.

VOLTAGE WAVEFORMS

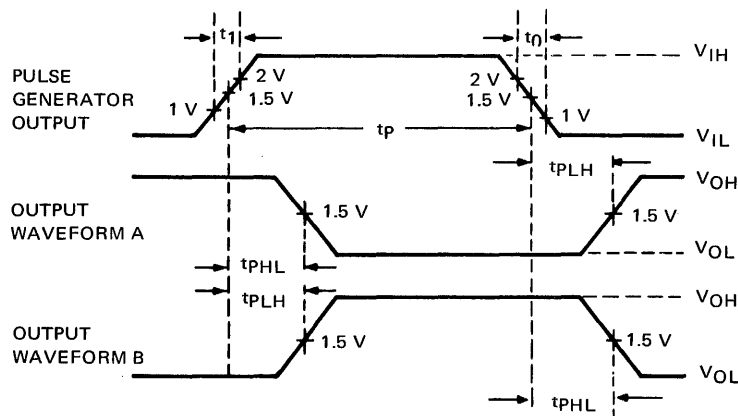

SWITCHING TIMES TEST TABLE (SEE NOTE 5)

TEST NO.	PARAMETER	APPLY PULSE GENERATOR OUTPUT TO	OUTPUT UNDER TEST (S4)	APPLY 2.4 V TO	APPLY GND TO	S1	S2	S3
1	t _{PLH}	C _{IN}	Σ ₁ (WAVEFORM A)	A ₁	A ₂ , B ₁ , B ₂	CLOSED	OPEN	OPEN
2	t _{PHL}							
3	t _{PLH}	B ₂	Σ ₂ (WAVEFORM B)	None	A ₁ , B ₁ , B ₂ and C _{IN}	OPEN	CLOSED	OPEN
4	t _{PHL}							
5	t _{PLH}	C _{IN}	Σ ₂ (WAVEFORM A)	A ₁ , A ₂	B ₁ , B ₂	OPEN	CLOSED	CLOSED
6	t _{PHL}							
7	t _{PLH}	C _{IN}	C ₂ (WAVEFORM B)	A ₁ , A ₂	B ₁ , B ₂	OPEN	OPEN	CLOSED
8	t _{PHL}							

NOTES:

- The generator has the following characteristics: V_{IH} ≥ 2.4 V, V_{IL} ≤ 0.4 V, t₁ = 8 to 15 ns, t₀ = 3 to 5 ns, PRR = 1 MHz, t_p = 200 ns, and Z_{out} ≈ 50 Ω.
- Perform test in accordance with test table.
- Each output is tested separately.
- Voltage values are with respect to network ground terminal.
- Inputs and outputs not otherwise specified are open.

Fig. A – SWITCHING TIMES

TTL/MSI 9383/5483, 7483

4-BIT BINARY FULL ADDER

DESCRIPTION – The TTL/MSI 9383/5483,7483 is a Full Adder which performs the addition of two 4-bit binary numbers. The sum (Σ) outputs are provided for each bit and the resultant carry (C_4) is obtained from the fourth bit. Designed for medium to high speed, multiple-bit, parallel-add/serial-carry applications, the circuit utilized high speed, high fan out TTL. The implementation of a single-inversion, high speed, Darlington-connected serial-carry circuit within each bit minimizes the necessity for extensive "lookahead" and carry-cascading circuits.

ABSOLUTE MAXIMUM RATINGS (above which the useful life may be impaired)

Storage Temperature	-65°C to +150°C
Temperature (Ambient) Under Bias	-55°C to +125°C
V _{CC} Pin Potential to Ground Pin	-0.5 V to +7.0 V
*Input Voltage (dc)	-0.5 V to +5.5 V
*Input Current (dc)	-30 mA to +5.0 mA
Voltage Applied to Outputs (Output HIGH)	-0.5 V to +V _{CC} value
Output Current (dc) (Output LOW)	+30 mA

*Either Input Voltage limit or Input Current limit is sufficient to protect the inputs.

PIN NAMES

A ₁ ,B ₁ ,A ₃ ,B ₃	Data Inputs	4 U.L.
A ₂ ,B ₂ ,A ₄ ,B ₄	Data Inputs	1 U.L.
C _{1N}	Carry Input	4 U.L.
$\Sigma_1, \Sigma_2, \Sigma_3, \Sigma_4$	Sum Outputs	10 U.L.
C ₄	Carry Out Bit 4	5 U.L.

LOADING

1 Unit Load (U.L.) = 40 μ A HIGH/1.6 mA LOW

LOGIC DIAGRAM

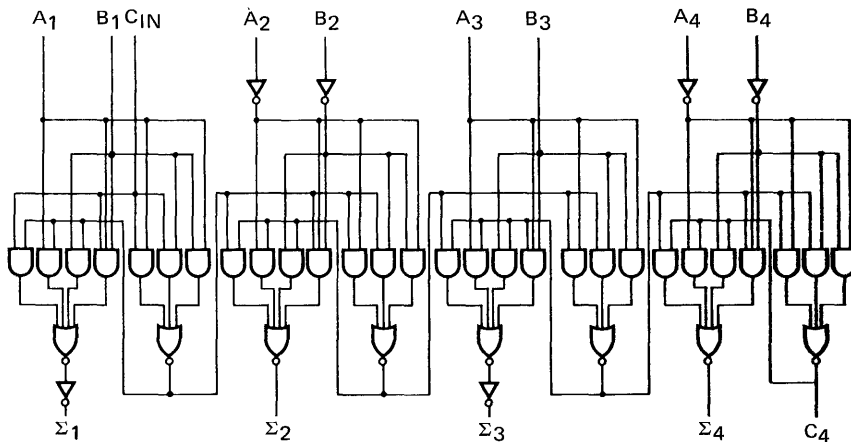

LOGIC SYMBOL

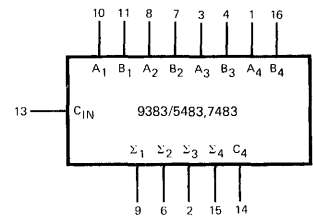

V_{CC} = Pin 5
GND = Pin 12

**CONNECTION DIAGRAM
DIP (TOP VIEW)**

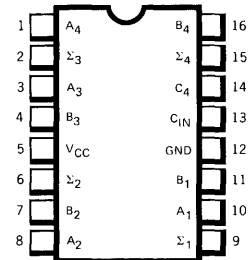

FLATPAK (TOP VIEW)

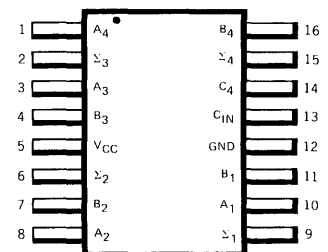

Positive logic: See truth table

TRUTH TABLE (See Note 1)

INPUT				OUTPUT							
				WHEN $C_{IN} = 0$				WHEN $C_{IN} = 1$			
				WHEN $C_2 = 0$				WHEN $C_2 = 1$			
A_1	B_1	A_2	B_2	Σ_1	Σ_2	C_2	Σ_1	Σ_2	C_2	Σ_3	Σ_4
A_3	B_3	A_4	B_4	Σ_3	Σ_4	C_4	Σ_3	Σ_4	C_4	Σ_3	Σ_4
L	L	L	L	L	L	L	L	H	L	L	L
H	L	L	L	H	L	L	L	H	H	L	L
L	H	L	L	H	L	L	L	H	H	L	L
H	H	L	L	L	H	L	L	H	H	H	L
L	L	H	L	L	H	L	H	H	H	L	L
H	L	H	L	H	H	L	L	L	L	H	L
L	H	H	L	H	H	L	L	L	L	L	H
H	H	H	L	L	L	H	H	H	L	H	L
L	L	L	H	L	H	L	H	H	H	L	L
H	L	L	H	H	H	L	L	L	L	L	H
L	H	L	H	H	H	L	L	L	L	L	H
H	H	L	H	L	L	H	H	H	L	H	L
L	L	L	H	L	L	H	H	H	L	L	H
H	L	H	H	L	L	H	H	L	H	L	H
L	H	H	H	H	L	H	L	H	H	H	L
H	H	H	H	L	H	H	H	H	H	H	H

NOTE:
 1. Input conditions at A_1, A_2, B_1, B_2 and C_{IN} are used to determine outputs Σ_1 and Σ_2 , and the value of the internal carry C_2 . The values at $C_2, A_3, B_3, A_4,$ and $B_4,$ are then used to determine outputs Σ_3, Σ_4 and C_4 .

RECOMMENDED OPERATING CONDITIONS

PARAMETER	9383XM/5483XM			9383XC/7483XC			UNITS
	MIN.	TYP.	MAX.	MIN.	TYP.	MAX.	
Supply Voltage V_{CC} (See Note 4)	4.5	5.0	5.5	4.75	5.0	5.25	Volts
Operating Free Air Temperature Range	-55	25	125	0	25	70	°C
Normalized Fan Out from Outputs	C_4		5.0			5.0	U. L.
	$\Sigma_1, \Sigma_2, \Sigma_3$ or Σ_4		10			10	U. L.

X = package type; F for Flatpak, D for Ceramic Dip, P for Plastic Dip. See Packaging Information Section for packages available on this product.

ELECTRICAL CHARACTERISTICS OVER OPERATING TEMPERATURE RANGE (Unless Otherwise Noted)

SYMBOL	PARAMETER	LIMITS			UNITS	TEST CONDITIONS (Note 1)	TEST FIGURE	
		MIN.	TYP. (Note 2)	MAX.				
V_{IH}	Input HIGH Voltage	2.0			Volts	Guaranteed V_{IH}	1 & 2	
V_{IL}	Input LOW Voltage			0.8	Volts	Guaranteed V_{IL}	1 & 2	
V_{OH}	Output HIGH Voltage	2.4			Volts	$V_{CC} = \text{MIN.}, I_{OH} = \text{See Fig.2}$	2	
V_{OL}	Output LOW Voltage			0.4	Volts	$V_{CC} = \text{MIN.}, I_{OL} = \text{See Fig.1}$	1	
I_{IH}	Input HIGH Current at A_1, A_3, B_1, B_3 or C_{IN}			160	μA	$V_{CC} = \text{MAX.}, V_{IN} = 2.4 V$	3	
				1.0	mA	$V_{CC} = \text{MAX.}, V_{IN} = 5.5 V$		
I_{IL}	Input LOW Current at A_2, A_4, B_2 or B_4			40	μA	$V_{CC} = \text{MAX.}, V_{IN} = 2.4 V$	3	
				1.0	mA	$V_{CC} = \text{MAX.}, V_{IN} = 5.5 V$		
I_{IL}	Input LOW Current at $A_1, A_3, B_1, B_3,$ or C_{IN}			-6.4	mA	$V_{CC} = \text{MAX.}, V_{IN} = 0.4 V$	3	
		Input LOW Current at A_2, A_4, B_2 or B_4			-1.6	mA	$V_{CC} = \text{MAX.}, V_{IN} = 0.4 V$	3
I_{OS}	Output Short Circuit Current at $\Sigma_1, \Sigma_2, \Sigma_3$ or Σ_4 (Note 3)		-20		-55	mA	9383/5483	$V_{CC} = \text{MAX.}$
		-18		-55	mA	9383/7483		
	Output Short Circuit Current at C_4 (Note 3)	-20		-70	mA	9383/5483	$V_{CC} = \text{MAX.}$	4
		-18		-70	mA	9383/7483		
I_{CC}	Supply Current		78	110	mA	9383/5483	$V_{CC} = \text{MAX.}$	3
			78	128	mA	9383/7483		

NOTES:

- (1) For conditions shown as MIN. or MAX., use the appropriate value specified under recommended operating conditions for the applicable device type.
- (2) Typical limits are at $V_{CC} = 5.0 V, 25^\circ C$.
- (3) Not more than one output should be shorted at a time.
- (4) These voltage values are with respect to network ground terminal.

SWITCHING CHARACTERISTICS ($T_A = 25^\circ\text{C}$)

SYMBOL	PARAMETER	LIMITS			UNITS	TEST CONDITIONS	FIGURE A TEST NO.	
		MIN.	TYP.	MAX.				
t_{PLH}	C_{IN} to Σ_1			34	ns	$V_{CC} = 5.0\text{ V}$ $C_L = 15\text{ pF}$ $R_L = 400\Omega$	1	
t_{PHL}				40			2	
t_{PLH}	C_{IN} to Σ_2			38	ns		3	
t_{PHL}				42			4	
t_{PLH}	C_{IN} to Σ_3			50	ns		5	
t_{PHL}				60			6	
t_{PLH}	C_{IN} to Σ_4			55	ns		7	
t_{PHL}				55			8	
t_{PLH}	C_{IN} to C_4		35	48	ns		$V_{CC} = 5.0\text{ V}$ $C_L = 15\text{ pF}$ $R_L = 780\Omega$	9
t_{PHL}			22	32				10
t_{PLH}	A_2 or B_2 to Σ_2			40	ns	$V_{CC} = 5.0\text{ V}$ $C_L = 15\text{ pF}$ $R_L = 400\Omega$	11 & 13	
t_{PHL}				35			12 & 14	
t_{PLH}	A_4 or B_4 to Σ_4			40	ns		15 & 17	
t_{PHL}				35			16 & 18	

PARAMETER MEASUREMENT INFORMATION

DC TEST CIRCUIT*

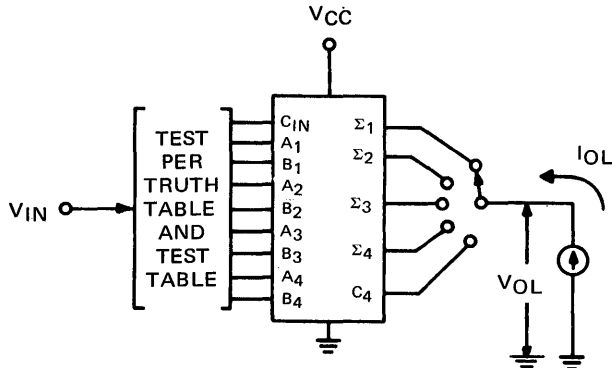

OUTPUT UNDER TEST	I_{OL}
$\Sigma_1, \Sigma_2, \Sigma_3,$ or Σ_4	16 mA
C_4	8 mA

1. Each input or output is tested separately.

Fig. 1

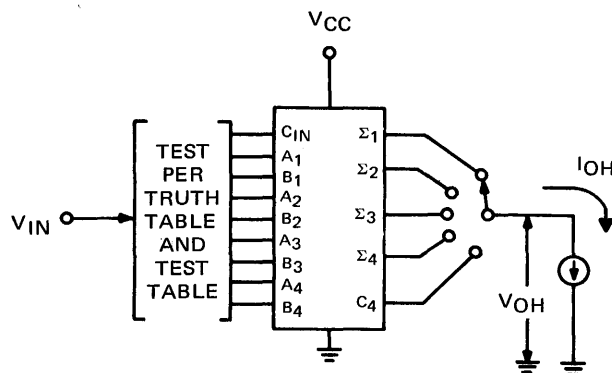

OUTPUT UNDER TEST	I_{OH}
$\Sigma_1, \Sigma_2, \Sigma_3,$ or Σ_4	-400 μA
C_4	-200 μA

1. Each input or output is tested separately.

Fig. 2

*Arrows indicate actual direction of current flow.

PARAMETER MEASUREMENT INFORMATION

DC TEST CIRCUITS* (continued)

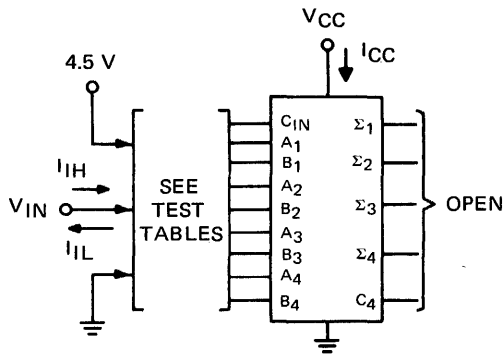

I_{IL} TEST TABLE

APPLY V _{IN} TEST I _{IN}	APPLY 4.5 V
C _{1N}	A ₁ and B ₁
A ₁	C _{1N} and B ₁
B ₁	C _{1N} and A ₁
A ₂	None
B ₂	None
A ₃	A ₂ , B ₂ , and B ₃
B ₃	A ₂ , B ₂ , and A ₃
A ₄	None
B ₄	None

I_{IH} TEST TABLE

APPLY V _{IN} TEST I _{IN}	GND
C _{1N}	A ₁ and B ₁
A ₁	C _{1N} and B ₁
B ₁	C _{1N} and A ₁
A ₂	None
B ₂	None
A ₃	A ₂ , B ₂ , and B ₃
B ₃	A ₂ , B ₂ , and A ₃
A ₄	None
B ₄	None

1. Each input is tested separately.
2. When testing I_{CC} apply 4.5 V to A₁, A₂, A₃, A₄, and C_{1N}; and ground B₁, B₂, B₃, and B₄.

Fig. 3

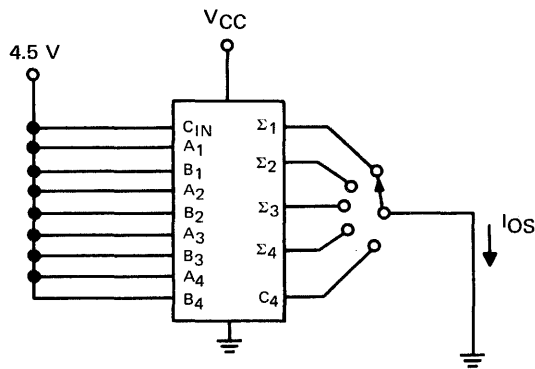

1. Each output is tested separately.

Fig. 4

*Arrows indicate actual direction of current flow.

PARAMETER MEASUREMENT INFORMATION

SWITCHING CHARACTERISTICS

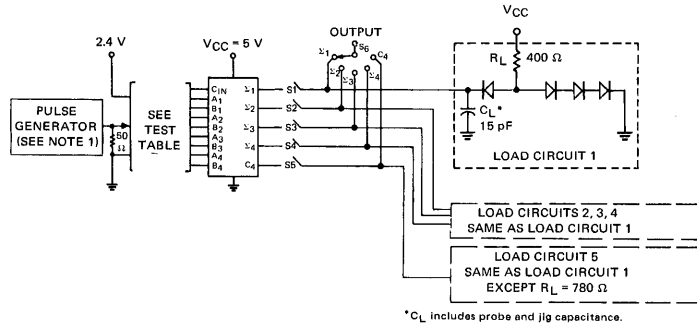

TEST CIRCUIT

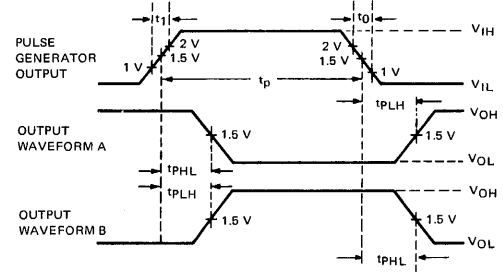

VOLTAGE WAVEFORMS

TEST TABLE (SEE NOTE 5)

TEST NO.	PARAMETER	APPLY PULSE GENERATOR OUTPUT TO	OUTPUT UNDER TEST (S6)	APPLY 2.4 V TO	APPLY GND TO	S1	S2	S3	S4	S5
1	t _{PLH}	C _{1N}	Σ ₁	A ₁	B ₁ , A ₂ , and B ₂	CLOSED	OPEN	OPEN	OPEN	OPEN
2	t _{PHL}		(WAVEFORM A)							
3	t _{PLH}	C _{1N}	Σ ₂	A ₁ and A ₂	B ₁ and B ₂	OPEN	CLOSED	OPEN	OPEN	OPEN
4	t _{PHL}		(WAVEFORM A)							
5	t _{PLH}	C _{1N}	Σ ₃	A ₁ , A ₂ , and A ₃	B ₁ , B ₂ , and B ₃	OPEN	OPEN	CLOSED	OPEN	OPEN
6	t _{PHL}		(WAVEFORM A)							
7	t _{PLH}	C _{1N}	Σ ₄	A ₁ , A ₂ , A ₃ , and A ₄	B ₁ , B ₂ , B ₃ , and B ₄	OPEN	OPEN	OPEN	CLOSED	CLOSED
8	t _{PHL}		(WAVEFORM A)							
9	t _{PLH}	C _{1N}	C ₄	A ₁ , A ₂ , A ₃ , and A ₄	B ₁ , B ₂ , B ₃ , and B ₄	OPEN	OPEN	OPEN	OPEN	CLOSED
10	t _{PHL}		(WAVEFORM B)							
11	t _{PLH}	A ₂	Σ ₂	None	A ₁ , B ₁ , B ₂ , and C _{1N}	OPEN	CLOSED	OPEN	OPEN	OPEN
12	t _{PHL}		(WAVEFORM B)							
13	t _{PLH}	B ₂	Σ ₂	None	A ₁ , B ₁ , A ₂ , and C _{1N}	OPEN	CLOSED	OPEN	OPEN	OPEN
14	t _{PHL}		(WAVEFORM B)							
15	t _{PLH}	A ₄	Σ ₄	None	A ₃ , B ₃ , and B ₄	OPEN	OPEN	OPEN	CLOSED	OPEN
16	t _{PHL}		(WAVEFORM B)							
17	t _{PLH}	B ₄	Σ ₄	None	A ₃ , B ₃ , and A ₄	OPEN	OPEN	OPEN	CLOSED	OPEN
18	t _{PHL}		(WAVEFORM B)							

NOTES:

1. Pulse generator output pulse characteristics: $V_{IH} \leq 2.4 \text{ V}$, $V_{IL} \leq 0.4 \text{ V}$, $t_1 = 8 \text{ to } 15 \text{ ns}$, $t_0 = 3 \text{ to } 5 \text{ ns}$, $\text{PRR} = 1 \text{ MHz}$, $t_p = 200 \text{ ns}$, and $Z_{out} \approx 50 \Omega$.
2. Perform test in accordance with test table.
3. Each output is tested separately.
4. Voltage values are with respect to network ground terminal.
5. Inputs and outputs not otherwise specified are open.

Fig. A – SWITCHING TIMES

TTL/MSI 9386

4-BIT QUAD EXCLUSIVE-NOR

DESCRIPTION — The 9386 consists of four independent Exclusive-NOR gates with open collector outputs. Single 1-bit comparisons may be made with each gate, or multiple bit comparisons may be made by connecting the outputs of the four gates together. Typical power dissipation is 170 mW.

ABSOLUTE MAXIMUM RATINGS (above which the useful life may be impaired)

Storage Temperature	-65°C to +150°C
Temperature (Ambient) Under Bias	-55°C to +125°C
V _{CC} Pin Potential to Ground Pin	-0.5 V to +7.0 V
*Input Voltage (dc)	-0.5 V to +5.5 V
*Input Current (dc)	-30 mA to +5.0 mA
Voltage Applied to Outputs (Output HIGH)	-0.5 V to +V _{CC} value
Output Current (dc) (Output LOW)	+30 mA

*Either Input Voltage limit or Input Current limit is sufficient to protect the inputs.

PIN NAMES

A₀ to A₃, B₀ to B₃
Q₀ to Q₃

Inputs
Outputs

LOADING

2.0 U.L.
15 U.L.

1 Unit Load (U.L.) = 40 μA HIGH/1.6 mA LOW

TRUTH TABLE

INPUTS		OUTPUT
A	B	Q
L	L	H
H	L	L
L	H	L
H	H	H

LOGIC DIAGRAM

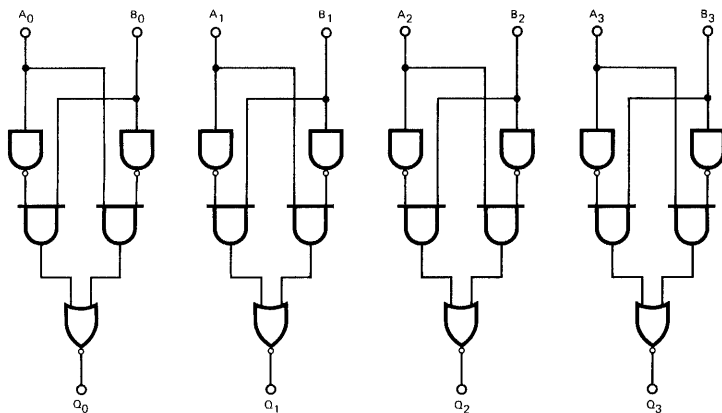

LOGIC SYMBOL

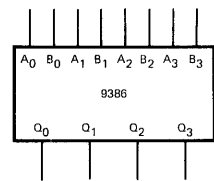

**CONNECTION DIAGRAM
DIP (TOP VIEW)**

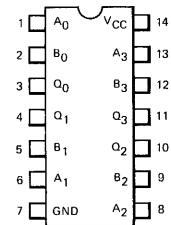

FLATPAK (TOP VIEW)

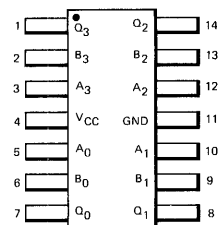

RECOMMENDED OPERATING CONDITIONS

PARAMETER	9386XM			9386XC			UNITS
	MIN.	TYP.	MAX.	MIN.	TYP.	MAX.	
Supply Voltage V_{CC}	4.5	5.0	5.5	4.75	5.0	5.25	Volts
Operating Free-Air Temperature Range	-55	25	125	0	25	70	°C

X=package type; F for Flatpak, D for Ceramic Dip, P for Plastic Dip. See Packaging Information Section for packages available on this product.

ELECTRICAL CHARACTERISTICS OVER OPERATING TEMPERATURE RANGE (Unless Otherwise Noted)

SYMBOL	PARAMETER	LIMITS			UNITS	CONDITIONS
		MIN.	TYP. (Note 4)	MAX.		
V_{IH}	Input HIGH Voltage	2.0			Volts	Guaranteed Input HIGH Voltage
V_{IL}	Input LOW Voltage			0.8	Volts	Guaranteed Input LOW Voltage
I_{CEX}	Output HIGH Leakage Current			150	μA	$V_{CC} = \text{MIN.}, V_{IN} = V_{IH}$ $V_{OUT} = 4.5 \text{ V}$
V_{OL}	Output LOW Voltage			0.4	Volts	$V_{CC} = \text{MIN.}, V_{IN}(A) = 2.0 \text{ V},$ $V_{IN}(B) = 0.8 \text{ V}, I_{OL} = 25 \text{ mA}$ (Note 3)
I_{IH}	Input HIGH Current			80	μA	$V_{CC} = \text{MAX.}, V_{IN}(A) = V_{IN}(B) =$ 4.5 V (Note 4)
I_{IL}	Input LOW Current	-0.1		-3.2	mA	$V_{CC} = \text{MAX.}, V_{IN}(A) = V_{IN}(B) =$ 0.4 V (Note 5)
I_{CC}	Supply Current		32	47.5	mA	$V_{CC} = 5.25 \text{ V}, V_{IN}(A) = V_{IN}(B) =$ 0.4 V
V_{LV}	Input Latch Voltage	A Input	5.5		Volts	$I_{IN}(A) = 10 \text{ mA}, V_{IN}(B) = 0 \text{ V}$
		B Input	5.5		Volts	$V_{IN}(A) = 0 \text{ V}, I_{IN}(B) = 10 \text{ mA}$ (Note 6)

SWITCHING CHARACTERISTICS ($T_A = 25^\circ C$)

SYMBOL	PARAMETER	LIMITS			UNITS	TEST CONDITIONS
		MIN.	TYP.	MAX.		
t_{PLH}	Turn Off Delay Input to Output		18	25	ns	$V_{CC} = 5.0 \text{ V}$
t_{PHL}	Turn On Delay Input to Output		18	25	ns	

NOTES:

- (1) For conditions shown as MIN. or MAX., use the appropriate value specified under recommended operating conditions for the applicable circuit type.
- (2) Typical limits are at $V_{CC} = 5.0 \text{ V}, 25^\circ C$.
- (3) Output sink current is supplied through a resistor to V_{CC} .
- (4) A and B are tested separately. When A is 4.5 V, B is 0 V, and vice versa.
- (5) A and B are tested separately. When A is 0.4 V, B is 5.25 V, and vice versa.
- (6) This test guarantees operation free of input latch-up over the specified operating supply voltage range.

SCHEMATIC DIAGRAMS

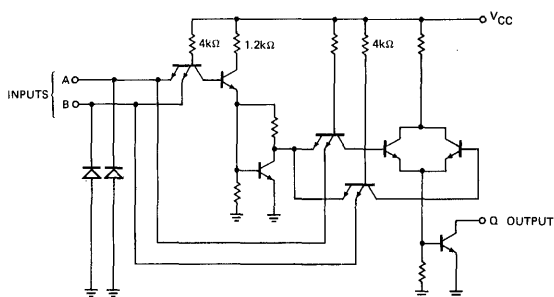

SWITCHING CHARACTERISTICS

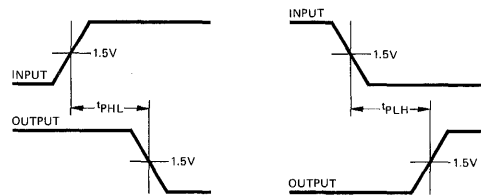

TTL/MSI 93H87/54H87, 74H87

HIGH SPEED 4-BIT TRUE/COMPLEMENT, ZERO/ONE ELEMENT

DESCRIPTION — The 93H87/54H87, 74H87 will perform four functions; use of the B and C control inputs determine the function performed. A 4-bit binary number (A) can be transferred to the output (Y) in either true or complementary form. In addition the control inputs can also set all outputs to LOW or HIGH independent of the state of the data inputs.

PIN NAMES

A₁, A₂, A₃, A₄ Data Inputs
 B, C Control Inputs
 Y₁, Y₂, Y₃, Y₄ Outputs

LOADING

1.0 U.L.
 1.0 U.L.
 10 U.L.

1 Unit Load (U.L.) = 40 μ A HIGH/1.6 mA LOW.

TRUTH TABLE

CONTROL INPUTS		OUTPUTS			
B	C	Y ₁	Y ₂	Y ₃	Y ₄
L	L	\bar{A}_1	\bar{A}_2	\bar{A}_3	\bar{A}_4
L	H	A ₁	A ₂	A ₃	A ₄
H	L	H	H	H	H
H	H	L	L	L	L

LOGIC DIAGRAM

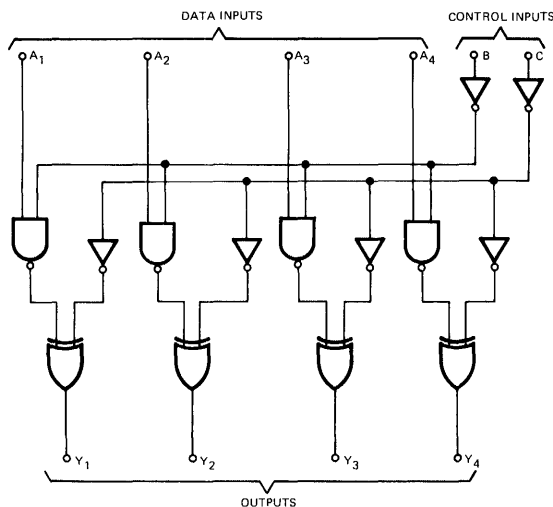

LOGIC SYMBOL

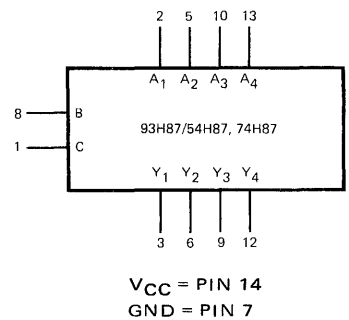

**CONNECTION DIAGRAM
 DIP (TOP VIEW)**

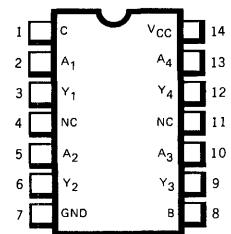

FLATPAK (TOP VIEW)

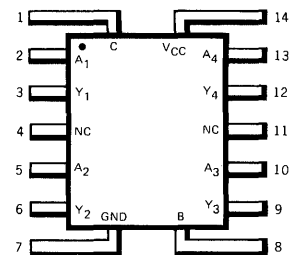

NC — No Internal Connection
 Positive Logic: See Truth Table

ABSOLUTE MAXIMUM RATINGS (above which the useful life may be impaired)

Storage Temperature	-65°C to +150°C
Temperature (Ambient) Under Bias	-55°C to +125°C
V _{CC} Pin Potential to Ground Pin	-0.5 V to +7.0 V
*Input Voltage (dc)	-0.5 V to +5.5 V
*Input Current (dc)	-30 mA to +5.0 mA
Voltage Applied to Outputs (Output HIGH)	-0.5 V to +V _{CC} value
Output Current (dc) (Output LOW)	+30 mA

*Either input voltage or input current limit is sufficient to protect the inputs.

RECOMMENDED OPERATING CONDITIONS

PARAMETER	93H87XM/54H87XM			93H87XC/74H87XC			UNITS
	MIN.	TYP.	MAX.	MIN.	TYP.	MAX.	
Supply Voltage V _{CC} (See Note 4)	4.5	5.0	5.5	4.75	5.0	5.25	Volts
Operating Free Air Temperature Range	-55	25	125	0	25	70	°C
Normalized Fan Out from Each Output, N	LOW Level		10			10	U.L.
	HIGH Level		20			20	

X = package type; F for Flatpak, D for Ceramic Dip, P for Plastic Dip. See Packaging Information Section for packages available on this product.

ELECTRICAL CHARACTERISTICS OVER OPERATING TEMPERATURE RANGE (Unless Otherwise Noted)

SYMBOL	PARAMETER	LIMITS			UNITS	TEST CONDITIONS (Note 1)	TEST FIGURE
		MIN.	TYP. (Note 2)	MAX.			
V _{IH}	Input HIGH Voltage	2.0			Volts	Guaranteed Input HIGH Threshold Voltage	1
V _{IL}	Input LOW Voltage			0.8	Volts	Guaranteed Input LOW Threshold Voltage	1
V _{OH}	Output HIGH Voltage	2.4			Volts	V _{CC} = MIN., I _{OH} = -1.0 mA, V _{IH} = 2.0 V, V _{IL} = 0.8 V	1
V _{OL}	Output LOW Voltage			0.4	Volts	V _{CC} = MIN., I _{OL} = 20 mA, V _{IH} = 2.0 V, V _{IL} = 0.8 V	1
I _{IH}	Input HIGH Current			50	μA	V _{CC} = MAX., V _{IN} = 2.4 V V _{CC} = MAX., V _{IN} = 5.5 V	Each Input
				1.0	mA		
I _{IL}	Input LOW Current			-2.0	mA	V _{CC} = MAX., V _{IN} = 0.4 V, Each Input	3
I _{OS}	Output Short Circuit Current (Note 3)	-40		-100	mA	V _{CC} = MAX., V _{OUT} = 0 V	4
I _{CC}	Supply Current		54	78	mA	93H87/54H87 93H87/74H87	V _{CC} = MAX.
			54	89	mA		

SWITCHING CHARACTERISTICS (T_A = 25°C)

SYMBOL	PARAMETER	LIMITS			UNITS	TEST CONDITIONS	TEST FIGURE
		MIN.	TYP.	MAX.			
t _{PLH}	Turn Off Delay Input to Output (Data Inputs to Outputs)		14	20	ns	V _{CC} = 5.0 V C _L = 25 pF R _L = 280 Ω	A
t _{PHL}	Turn On Delay Input to Output (Data Inputs to Outputs)		13	19	ns		
t _{PLH}	Turn Off Delay Input to Output (Control Inputs to Outputs)		17	25	ns		
t _{PHL}	Turn On Delay Input to Output (Control Inputs to Outputs)		17	25	ns		

NOTES:

- (1) For conditions shown as MIN. or MAX., use the appropriate value specified under recommended operating conditions for the applicable circuit type.
- (2) Typical limits are at V_{CC} = 5.0 V, 25°C.
- (3) Not more than one output should be shorted at a time.
- (4) These voltage values are with respect to network ground terminal.

PARAMETER MEASUREMENT INFORMATION

DC TEST CIRCUITS*

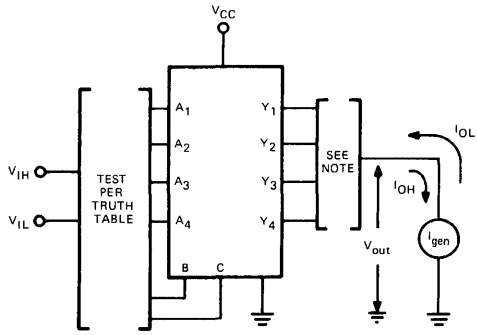

1. Each output is tested separately.

Fig. 1

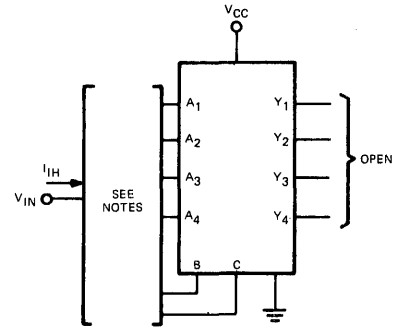

1. Each input is tested separately.
2. When testing A₁, A₂, A₃ or A₄ input B is at 4.5 V.

Fig. 2

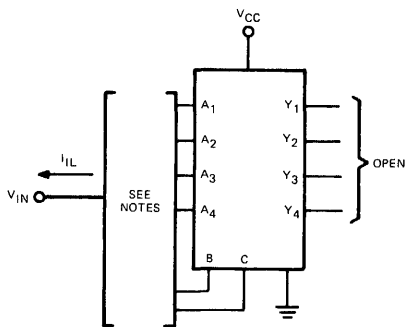

1. Each input is tested separately.
2. When testing A₁, A₂, A₃ or A₄ input B is grounded.

Fig. 3

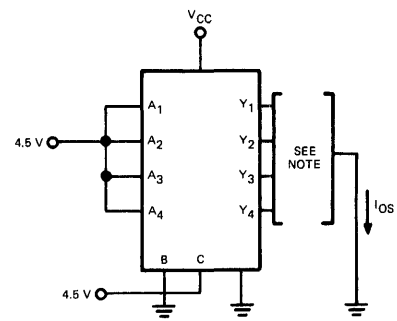

1. Each output is tested separately.

Fig. 4

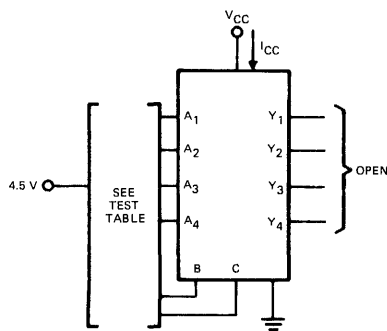

Fig. 5

TEST TABLE

TEST NO.	APPLY 4.5 V	GROUND
1	A ₁ , A ₂ , A ₃ , A ₄	B, C,
2	B, C	A ₁ , A ₂ , A ₃ , A ₄

*Arrows indicate actual direction of current flow.

PARAMETER MEASUREMENT INFORMATION (cont'd)

SWITCHING CHARACTERISTICS

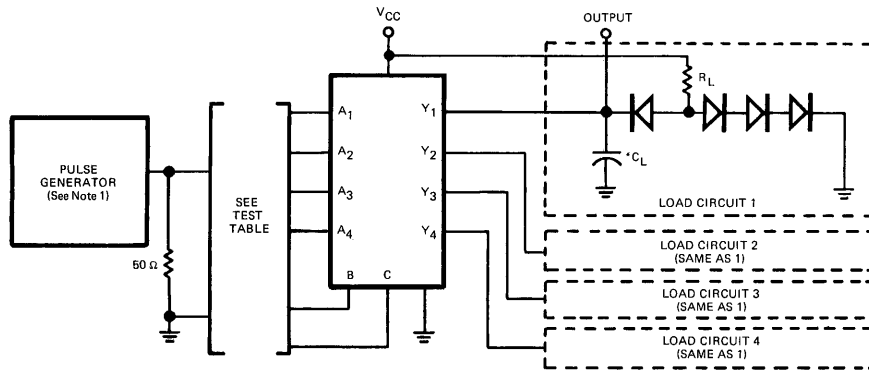

* C_L includes probe and jig capacitance.

TEST CIRCUIT

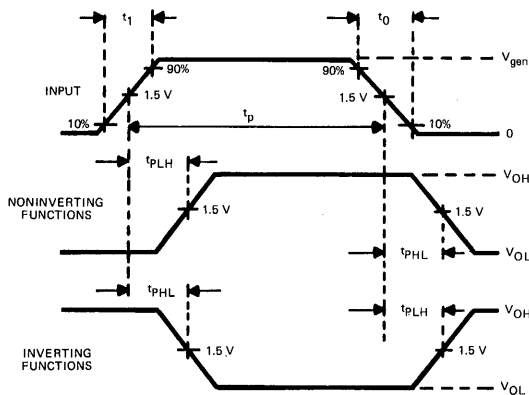

TEST TABLE (See Note 2)

GND	INPUT	OUTPUT
B, C	A1	Y1
B, C	A2	Y2
B, C	A3	Y3
B, C	A4	Y4
C	B	Y1
C	B	Y2
C	B	Y3
C	B	Y4
B	C	Y1
B	C	Y2
B	C	Y3
B	C	Y4

VOLTAGE WAVEFORMS

NOTES:

1. The pulse generator has the following characteristics: $V_{gen} = 3\text{ V}$, $t_1 = t_0 = 7\text{ ns}$, $t_p = 500\text{ ns}$, $PRR = 1\text{ MHz}$, and $Z_{out} \approx 50\Omega$.
2. Inputs not specified are open.

Fig. A – SWITCHING TIMES

TTL/MSI 9390/5490, 7490

DECADE COUNTER

DESCRIPTION — The TTL/MSI 9390/5490, 7490 is a Decade Counter which consists of four dual rank, master slave flip-flops internally interconnected to provide a divide-by-two counter and a divide-by-five counter. Count inputs are inhibited, and all outputs are returned to logical zero or a binary coded decimal (BCD) count of 9 through gated direct reset lines. The output from flip-flop A is not internally connected to the succeeding stages, therefore the count may be separated into these independent count modes:

- A. If used as a binary coded decimal decade counter, the \overline{CP}_{BD} input must be externally connected to the Q_A output. The \overline{CP}_A input receives the incoming count, and a count sequence is obtained in accordance with the BCD count for nine's complement decimal application.
- B. If a symmetrical divide-by-ten count is desired for frequency synthesizers or other applications requiring division of a binary count by a power of ten, the Q_D output must be externally connected to the \overline{CP}_A input. The input count is then applied at the \overline{CP}_{BD} input and a divide-by-ten square wave is obtained at output Q_A .
- C. For operation as a divide-by-two counter and a divide-by-five counter, no external interconnections are required. Flip-flop A is used as a binary element for the divide-by-two function. The \overline{CP}_{BD} input is used to obtain binary divide-by-five operation at the Q_B , Q_C , and Q_D outputs. In this mode, the two counters operate independently; however, all four flip-flops are reset simultaneously.

PIN NAMES

R_0	Reset-Zero Inputs	1 U.L.
R_9	Reset-Nine Inputs	1 U.L.
\overline{CP}_A	Clock Input	2 U.L.
\overline{CP}_{BD}	Clock Input	4 U.L.
Q_A, Q_B, Q_C, Q_D	Outputs	10 U.L.

1 Unit Load (U.L.) = 40 μ A HIGH/1.6mA LOW.

COUNT	OUTPUT			
	Q_D	Q_C	Q_B	Q_A
0	L	L	L	L
1	L	L	L	H
2	L	L	H	L
3	L	L	H	H
4	L	H	L	L
5	L	H	L	H
6	L	H	H	L
7	L	H	H	H
8	H	L	L	L
9	H	L	L	H

TRUTH TABLES

RESET INPUTS				OUTPUT			
$R_0(1)$	$R_0(2)$	$R_9(1)$	$R_9(2)$	Q_D	Q_C	Q_B	Q_A
H	H	L	X	L	L	L	L
H	H	X	H	L	L	L	L
X	X	H	H	H	L	L	H
X	L	X	L	L	X	L	COUNT
L	X	L	X	L	X	L	COUNT
L	X	X	L	L	X	L	COUNT
X	L	L	X	X	L	X	COUNT

- NOTES:
 1. Output Q_A connected to input \overline{CP}_{BD} for BCD count.
 2. X indicates that either a HIGH level or a LOW level may be present.

LOGIC DIAGRAM

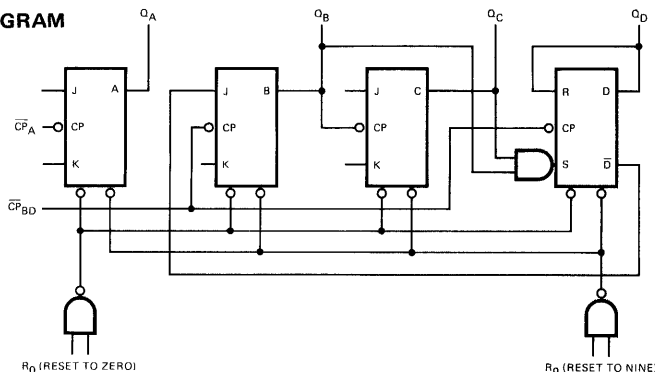

LOGIC SYMBOL

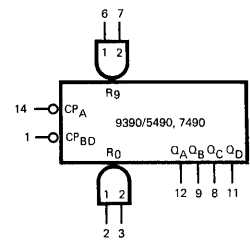

V_{CC} = Pin 5
 GND = Pin 10
 NC = Pin 4, 13

CONNECTION DIAGRAM DIP (TOP VIEW)

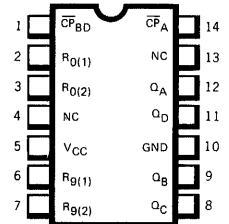

FLAT PAK (TOP VIEW)

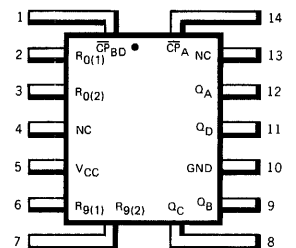

Positive logic: See Truth Table.
 NC — No internal connection.

ABSOLUTE MAXIMUM RATINGS (above which the useful life may be impaired)

Storage Temperature	-65°C to +150°C
Temperature (Ambient) Under Bias	-55°C to +125°C
V _{CC} Pin Potential to Ground Pin	-0.5 V to +7.0 V
*Input Voltage (dc)	-0.5 V to +5.5 V
*Input Current (dc)	-30 mA to +5.0 mA
Voltage Applied to Outputs (Output HIGH)	-0.5 V to +V _{CC} value
Output Current (dc) (Output LOW)	+30 mA

*Either Input Voltage limit or Input Current limit is sufficient to protect the inputs.

RECOMMENDED OPERATING CONDITIONS

PARAMETER	9390XM/5490XM			9390XC/7490XC			UNITS
	MIN.	TYP.	MAX.	MIN.	TYP.	MAX.	
Supply Voltage V _{CC} (Note 4)	4.5	5.0	5.5	4.75	5.0	5.25	Volts
Operating Free-Air Temperature Range	-55	25	125	0	25	70	°C
Normalized Fan Out from Each Output, N (Note 5)			10			10	U.L.
Width of Input Count Pulse, t _{p(in)}	50			50			ns
Width of Reset Pulse, t _{p(reset)}	50			50			ns

X=package type; F for Flatpak, D for Ceramic Dip, P for Plastic Dip. See Packaging Information Section for packages available on this product.

ELECTRICAL CHARACTERISTICS OVER OPERATING TEMPERATURE RANGE (Unless Otherwise Noted)

SYMBOL	PARAMETER	LIMITS			UNITS	TEST CONDITIONS (Note 1)	TEST FIGURE		
		MIN.	TYP. (Note 2)	MAX.					
V _{IH}	Input HIGH Voltage	2.0			Volts	Guaranteed Input HIGH Voltage	1		
V _{IL}	Input LOW Voltage			0.8	Volts	Guaranteed Input LOW Voltage	2		
V _{OH}	Output HIGH Voltage	2.4			Volts	V _{CC} = MIN., I _{OH} = -0.4 mA	2		
V _{OL}	Output LOW Voltage			0.4	Volts	V _{CC} = MIN., I _{OL} = 16 mA	1		
I _{IH}	Input HIGH Current at R ₀ (1), R ₀ (2), R ₉ (1), or R ₉ (2)			40	μA	V _{CC} = MAX., V _{IN} = 2.4 V	3		
				1.0	mA	V _{CC} = MAX., V _{IN} = 5.5 V			
	Input HIGH Current at Input \overline{CP}_A			80	μA	V _{CC} = MAX., V _{IN} = 2.4 V	3		
				1.0	mA	V _{CC} = MAX., V _{IN} = 5.5 V			
I _{IL}	Input LOW Current at Input \overline{CP}_{BD}			160	μA	V _{CC} = MAX., V _{IN} = 2.4 V	3		
				1.0	mA	V _{CC} = MAX., V _{IN} = 5.5 V			
				-1.6	mA	V _{CC} = MAX., V _{IN} = 0.4 V			
I _{IL}	Input LOW Current at R ₀ (1), R ₀ (2), R ₉ (1), or R ₉ (2)			-3.2	mA	V _{CC} = MAX., V _{IN} = 0.4 V	4		
				-6.4	mA	V _{CC} = MAX., V _{IN} = 0.4 V			
				-20		-57		mA	9390/5490
I _{OS}	Output Short Circuit Current (Note 3)			-18		-57	mA	9390/7490	V _{CC} = MAX.
		I _{CC}	Supply Current		32	46	mA	9390/5490	3
	32			53	mA	9390/7490	V _{CC} = MAX.		

SWITCHING CHARACTERISTICS (T_A = 25°C)

SYMBOL	PARAMETER	LIMITS			UNITS	TEST CONDITIONS	TEST FIGURE
		MIN.	TYP.	MAX.			
f _{max}	Maximum Frequency of Input Count Pulse	10	18		MHz	V _{CC} = 5.0 V C _L = 15 pF R _L = 400Ω	
t _{PLH}	Turn Off Delay from Input Count Pulse to Output Q _C		60	100	ns		A
t _{PHL}	Turn On Delay from Input Count Pulse to Output Q _C		60	100	ns		A

NOTES:

- (1) For conditions shown as MIN. or MAX., use the appropriate value specified under recommended operating conditions for the applicable circuit type.
- (2) Typical limits are at V_{CC} = 5.0 V, 25°C.
- (3) Not more than one output should be shorted at a time.
- (4) These voltage values are with respect to network ground terminal.
- (5) Fan out from output Q_A to input \overline{CP}_{BD} and to 10 additional series 54/74 loads is permitted.

PARAMETER MEASUREMENT INFORMATION

DC TEST CIRCUIT*

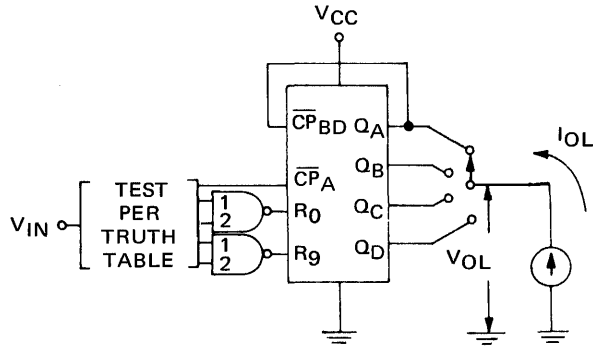

1. Each output is tested in the LOW level state.

Fig. 1

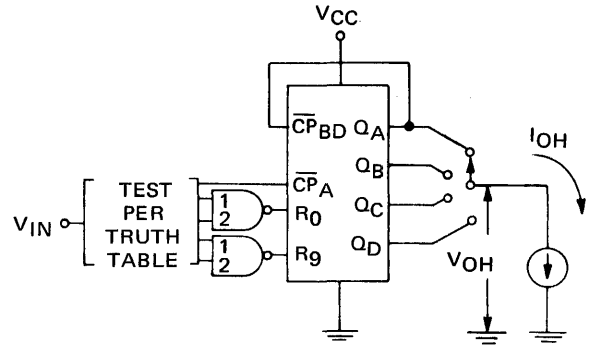

1. Each output is tested in the HIGH level state.

Fig. 2

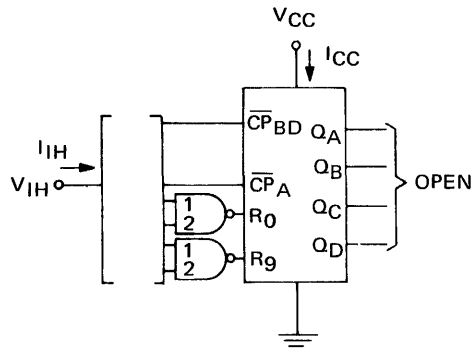

1. Each input is tested separately.
2. When testing R₀(1) or R₉(1) ground R₀(2) or R₉(2).
3. When testing R₀(2) or R₉(2) ground R₀(1) or R₉(1).
4. When testing I_{CC} reset all outputs to LOW level, ground all inputs, then measure I_{CC}.

Fig. 3

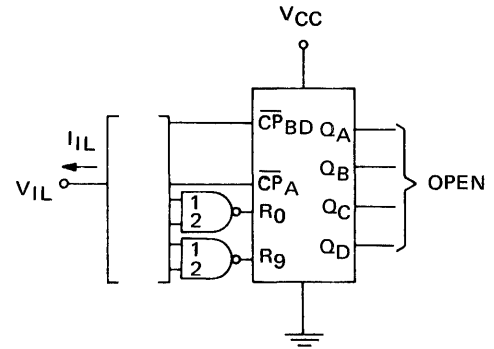

1. Each input is tested separately.
2. When testing R₀(1) or R₉(1) apply 4.5 V to R₀(2) or R₉(2).
3. When testing R₀(2) or R₉(2) apply 4.5 V to R₀(1) or R₉(1).

Fig. 4

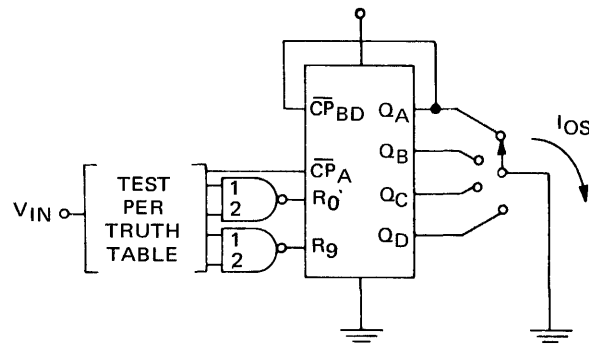

1. Each output is tested in the HIGH level state.

Fig. 5

*Arrows indicate actual direction of current flow.

PARAMETER MEASUREMENT INFORMATION (Con't.)

SWITCHING CHARACTERISTICS

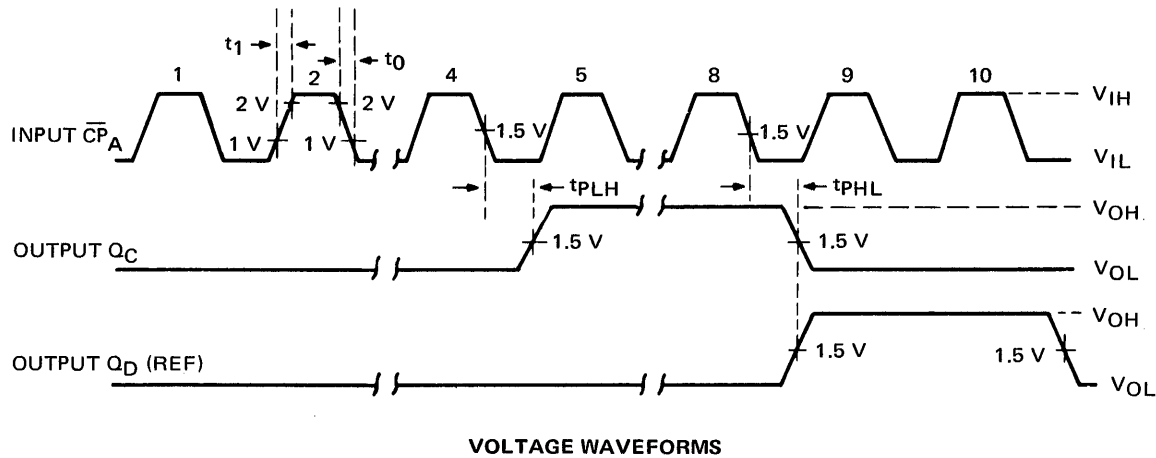
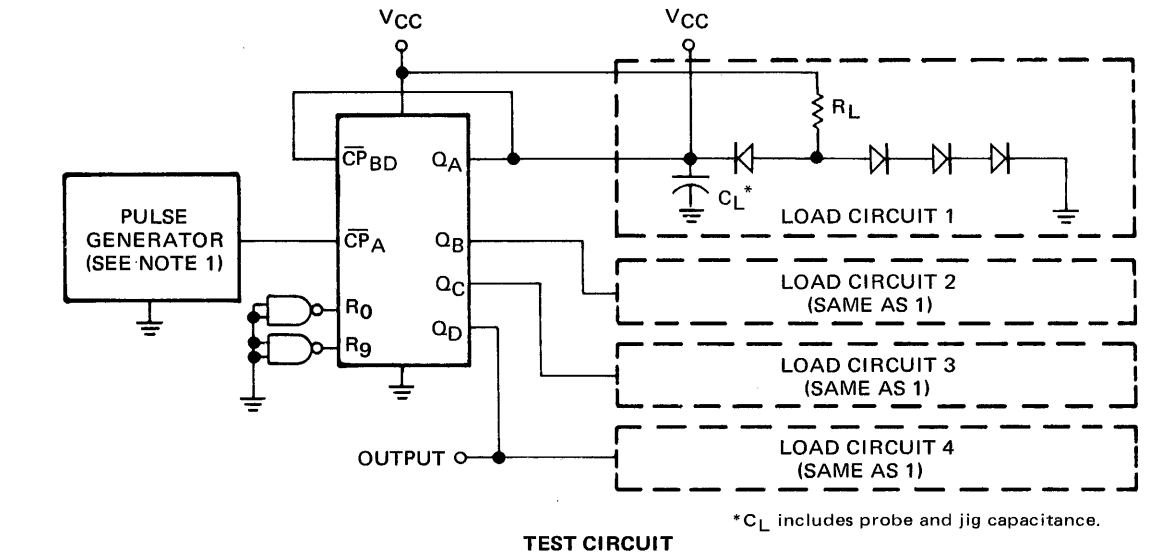

NOTES:

1. The pulse generator has the following characteristics: $V_{gen} = 3\text{ V}$, $t_0 = t_1 \leq 15\text{ ns}$, $t_p = 0.5\text{ }\mu\text{s}$, $PRR = 1\text{ MHz}$, $Z_{out} \approx 50\Omega$.
2. Propagation Delay = $\frac{t_{PHL} + t_{PLH}}{2}$
3. Voltage values are with respect to ground terminal.

Fig. A – SWITCHING TIMES

TTL/MSI 9391/5491, 7491

8-BIT SHIFT REGISTER

DESCRIPTION — The TTL/MSI 9391/5491, 7491 is a serial-in, serial-out, 8-Bit Shift Register utilizing TTL technology. It is composed of eight RS master/slave flip-flops, input gating, and a clock driver. The register is capable of storing and transferring data at clock rates up to 18 MHz while maintaining a typical noise-immunity level of 1.0V. Power dissipation is typically 175 mW; a full fan out of 10 is available from the outputs.

Single-rail data and input control are gated through inputs A and B and an internal inverter to form the complementary inputs to the first bit of the shift register. Drive for the internal common clock line is provided by an inverting clock driver. Each of the inputs (A, B, and \overline{CP}) appear as only one TTL input load.

The clock pulse inverter/driver causes these circuits to shift information to the output on the positive edge of an input clock pulse, thus enabling the shift-register to be fully compatible with other edge-triggered synchronous functions.

PIN NAMES

A, B	Data Inputs
Q, \overline{Q}	Data Output
\overline{CP}	Clock Input

LOADING

1 U.L.
10 U.L.
1 U.L.

1 Unit Load (U.L.) = 40 μ A HIGH/1.6 mA LOW

TRUTH TABLE

t_n		t_{n+8}
A	B	Q
L	L	L
L	H	L
H	L	L
H	H	H

NOTES:

t_n = Bit time before clock pulse.
 t_{n+8} = Bit time after 8 clock pulses.

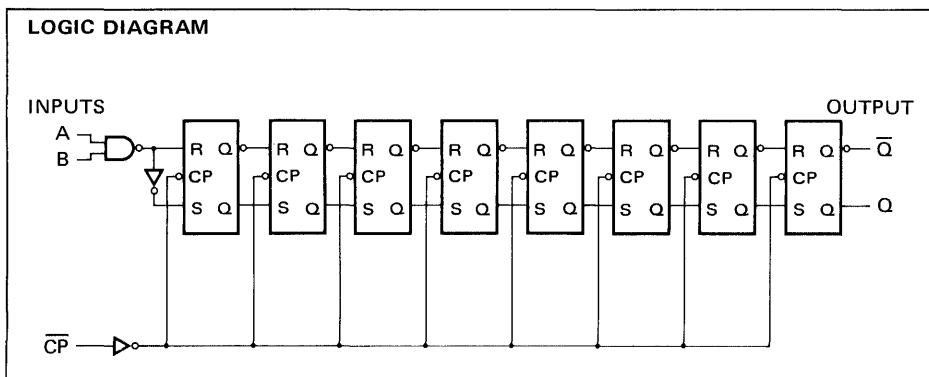

LOGIC SYMBOL

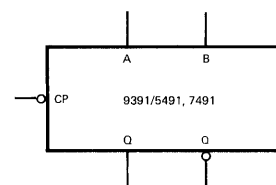

CONNECTION DIAGRAM DIP (TOP VIEW)

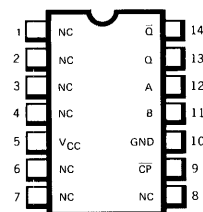

FLATPAK (TOP VIEW)

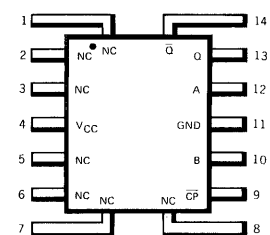

NC—No Internal Connection
 Positive logic: See truth table.

TTL/MSI • 9391/5491, 7491

ABSOLUTE MAXIMUM RATINGS (above which the useful life may be impaired)

Storage Temperature	-65°C to +150°C
Temperature (Ambient) Under Bias	-55°C to +125°C
V _{CC} Pin Potential to Ground Pin	-0.5 V to +7.0 V
*Input Voltage (dc)	-0.5 V to +5.5 V
*Input Current (dc)	-30 mA to +5.0 mA
Voltage Applied to Outputs (Output HIGH)	-0.5 V to +V _{CC} value
Output Current (dc) (Output LOW)	+30 mA

*Either Input Voltage limit or Input Current limit is sufficient to protect the inputs.

RECOMMENDED OPERATING CONDITIONS

PARAMETER	9391XM/5491XM			9391XC/7491XC			UNITS
	MIN.	TYP	MAX.	MIN.	TYP .	MAX.	
Supply Voltage V _{CC} (Note 4)	4.5	5.0	5.5	4.75	5.0	5.25	Volts
Operating Free-Air Temperature Range	-55	25	125	0	25	70	°C
Normalized Fan Out from Outputs			10			10	U.L.
Width of Clock Pulse, t _{p(clock)} (See Fig. A)	25			25			ns
Input Setup Time, t _{setup} (See Fig. A)	25			25			ns
Input Hold Time, t _{hold} (See Fig. A)	0			0			

X = package type; F for Flatpak, D for Ceramic Dip, P for Plastic Dip. See Packaging Information Section for packages available on this product.

ELECTRICAL CHARACTERISTICS OVER OPERATING TEMPERATURE RANGE (Unless Otherwise Noted)

SYMBOL	PARAMETER	LIMITS			UNITS	TEST CONDITIONS (Note 1)	TEST FIGURE
		MIN.	TYP. (Note 2)	MAX.			
V _{IH}	Input HIGH Voltage	2.0			Volts	Guaranteed V _{IH}	1
V _{IL}	Input LOW Voltage			0.8	Volts	Guaranteed V _{IL}	2
V _{OH}	Output HIGH Voltage	2.4	3.5		Volts	V _{CC} = MIN., I _{OH} = -0.4 mA	1
V _{OL}	Output LOW Voltage		0.22	0.4	Volts	V _{CC} = MIN., I _{OL} = 16 mA	2
I _{IH}	Input HIGH Current			40	μA	V _{CC} = MAX., V _{IN} = 2.4 V	4
				1.0	mA	V _{CC} = MAX., V _{IN} = 5.5 V	
I _{IL}	Input LOW Current			-1.6	mA	V _{CC} = MAX., V _{IN} = 0.4V	3
I _{OS}	Output Short Circuit Current (Note 3)	-20		-57	mA	9391/5491 V _{CC} = MAX.	5
		-18		-57	mA	9391/7491 V _{OUT} = 0V	
I _{CC}	Supply Current		35	50	mA	9391/5491 V _{CC} = MAX.	6
			35	58	mA	9391/7491 V _{IN} = 4.5 V	

SWITCHING CHARACTERISTICS (T_A = 25°C)

SYMBOL	PARAMETER	LIMITS			UNITS	TEST CONDITIONS	TEST FIGURE
		MIN.	TYP.	MAX.			
f _{max}	Maximum Clock Frequency	10	18		MHz	V _{CC} = 5.0 V	
t _{PLH}	Turn Off Delay from Clock to Output		24	40	ns	C _L = 15 pF	A
t _{PHL}	Turn On Delay from Clock to Output		27	40	ns	R _L = 400Ω	A

NOTES:

- (1) For conditions shown as MIN. or MAX., use the appropriate value specified under recommended operating conditions for the applicable circuit type.
- (2) Typical limits are at V_{CC} = 5.0 V, 25°C.
- (3) Not more than one output should be shorted at a time.
- (4) These voltage values are with respect to network ground terminal.

PARAMETER MEASUREMENT INFORMATION

DC TEST CIRCUITS*

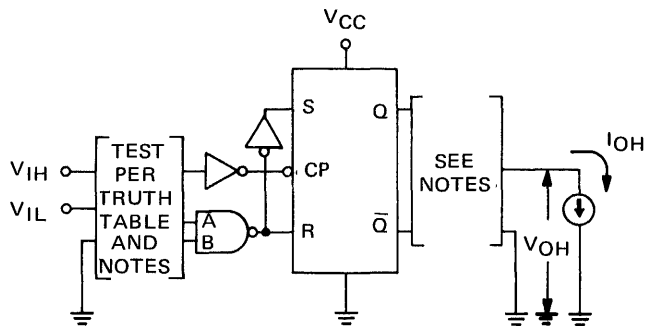

1. Each output is tested separately.
2. When testing V_{OH} and I_{OH} ground all inputs and the unused output, then measure parameters specified.

Fig. 1

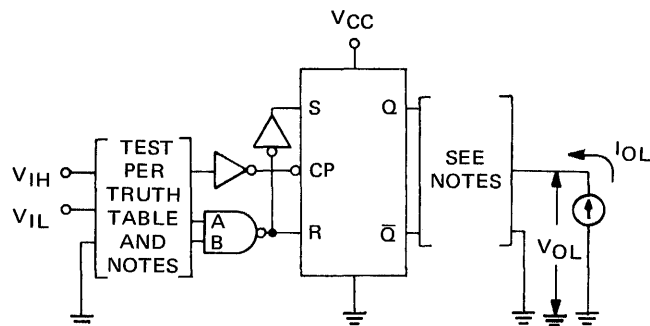

1. Each output is tested separately.
2. When testing V_{OL} and I_{OL} ground all inputs. Apply a momentary ground to the output to be tested then measure parameters specified.

Fig. 2

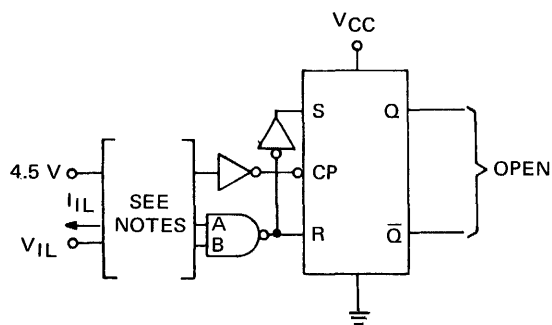

1. When testing input A apply 4.5 V to input B.
2. When testing input B apply 4.5 V to input A.

Fig. 3

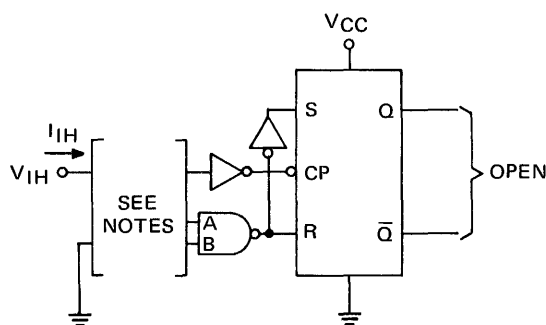

1. When testing input A ground input B.
2. When testing input B ground input A.

Fig. 4

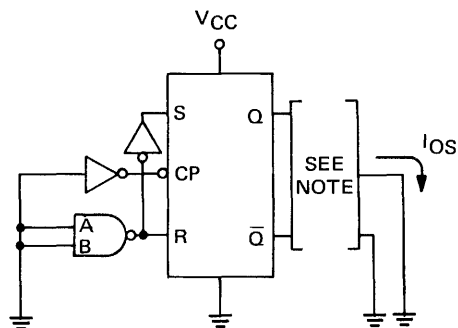

1. Ground the unused output then measure parameter specified.

Fig. 5

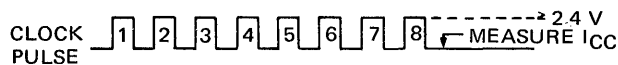
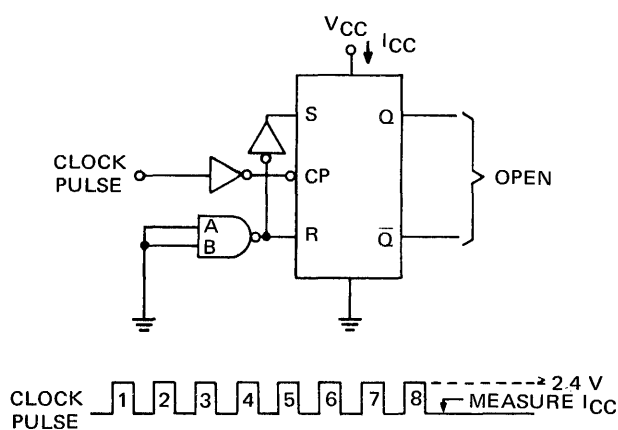
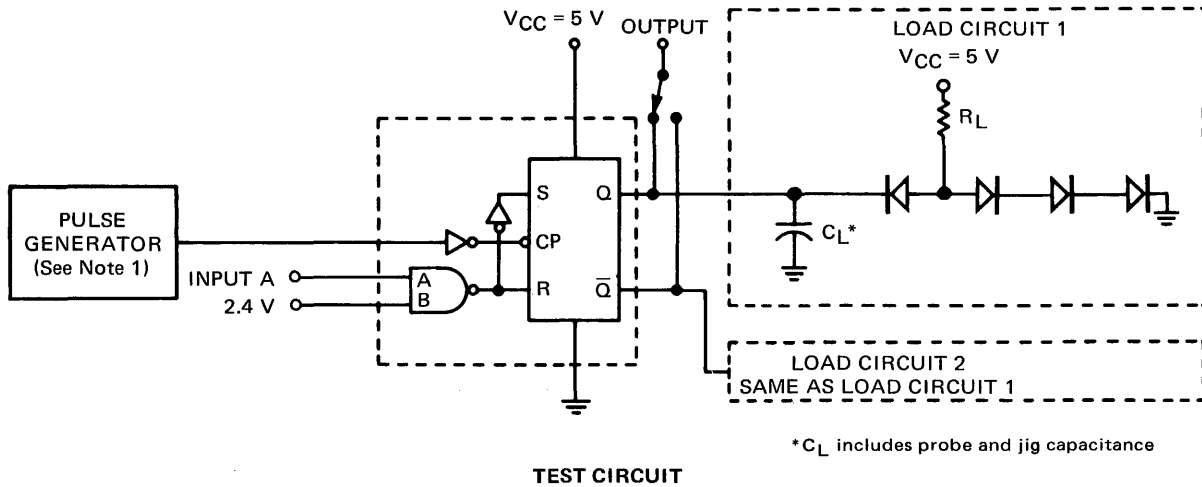

Fig. 6

* Arrows indicate actual direction of current flow.

PARAMETER MEASUREMENT INFORMATION (Con't)

SWITCHING CHARACTERISTICS



TEST CIRCUIT

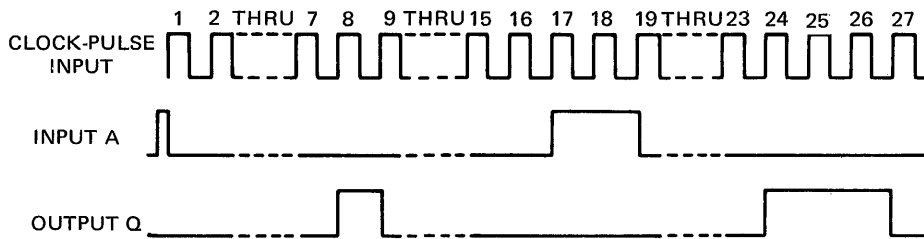

TYPICAL INPUT/OUTPUT WAVEFORMS

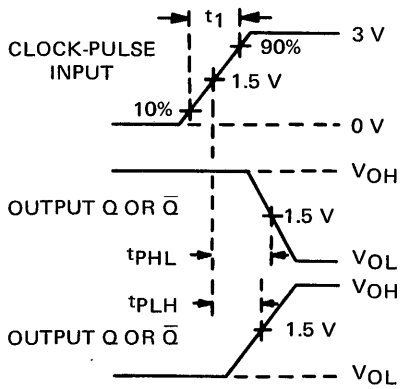

PROPAGATION DELAY TIME VOLTAGE WAVEFORM

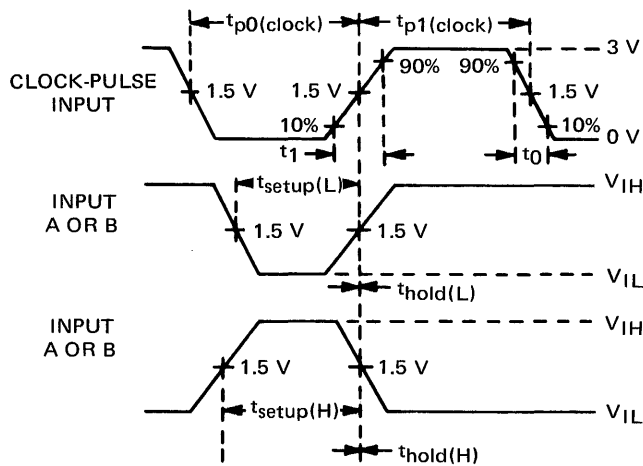

SWITCHING TIME VOLTAGE WAVEFORM

NOTES:

1. The generator has the following characteristics: $V_{IL} \leq 0.3V$, $V_{IH} \geq 2.4V$, $t_1 = t_0 = 10\text{ ns}$, $t_{p1}(\text{clock}) = 500\text{ ns}$, $t_{p0}(\text{clock}) = 500\text{ ns}$, $\text{PRR} = 1\text{ MHz}$, and $Z_{out} \approx 50\Omega$.
2. Each output is tested separately.
3. Voltage values are with respect to network ground terminal.

Fig. A 9391/5491, 7491 SWITCHING TIMES

TTL/MSI 9392/5492, 7492

DIVIDE-BY-TWELVE COUNTER

(DIVIDE-BY-TWO AND DIVIDE-BY-SIX)

DESCRIPTION – The TTL/MSI 9392/5492, 7492 is a 4-Bit Binary Counter consisting of four master slave flip-flops which are internally interconnected to provide a divide-by-two counter and a divide-by-six counter. A gated direct reset line is provided which inhibits the count inputs and simultaneously returns the four flip-flop outputs to a LOW level. As the output from flip-flop A is not internally connected to the succeeding flip-flops, the counter may be operated in two independent modes:

- A. When used as a divide-by-twelve counter, output Q_A must be externally connected to input \overline{CP}_{BC} . The input count pulses are applied to input \overline{CP}_A . Simultaneous divisions of 2, 6 and 12 are performed at the Q_A , Q_C and Q_D outputs as shown in the truth table.
- B. When used as a divide-by-six counter, the input count pulses are applied to input \overline{CP}_{BC} . Simultaneously, frequency divisions of 3 and 6 are available at the Q_C and Q_D outputs. Independent use of flip-flop A is available if the reset function coincides with reset of the divide-by-six counter.

These circuits are completely compatible with TTL and DTL logic families.

PIN NAMES

R_0	Reset-Zero Inputs
\overline{CP}_A	Clock Input
\overline{CP}_{BC}	Clock Input
Q_A, Q_B, Q_C, Q_D	Count Outputs

1 Unit Load (U.L.) = 40 μ A HIGH/1.6 mA LOW.

TRUTH TABLE

(See Notes 1, 2 and 3)

COUNT	OUTPUT			
	Q_D	Q_C	Q_B	Q_A
0	L	L	L	L
1	L	L	L	H
2	L	L	H	L
3	L	L	H	H
4	L	H	L	L
5	L	H	L	H
6	H	L	L	L
7	H	L	L	H
8	H	L	H	L
9	H	L	H	H
10	H	H	L	L
11	H	H	L	H

NOTES:

1. Output Q_A connected to input \overline{CP}_{BC} .
2. To reset all outputs to LOW level both $R_0(1)$ and $R_0(2)$ inputs must be at HIGH level state.
3. Either (or both) reset inputs $R_0(1)$ and $R_0(2)$ must be at a LOW level to count.

LOGIC DIAGRAM

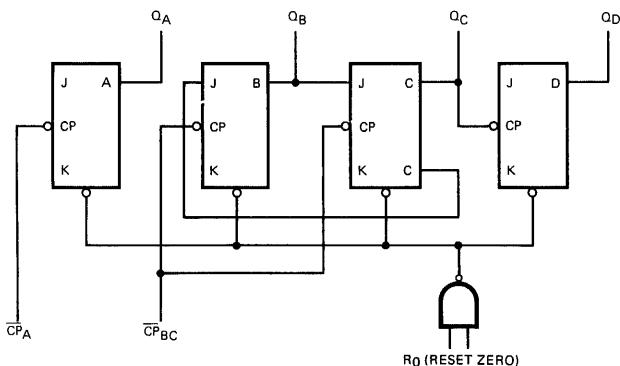

LOGIC SYMBOL

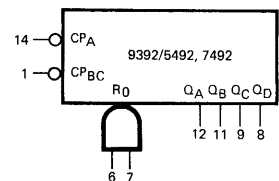

V_{CC} = Pin 5
 GND = Pin 10
 N.C. = Pins 2, 3, 4, 13

LOADING

1 U.L.
 2 U.L.
 4 U.L.
 10 U.L.

CONNECTION DIAGRAM DIP (TOP VIEW)

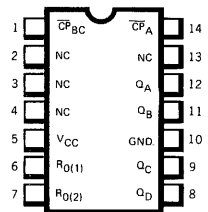

FLATPAK (TOP VIEW)

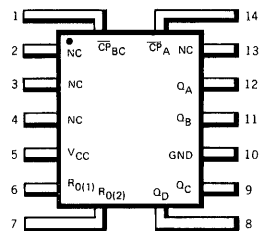

Positive logic: See truth table.

NC – No internal connection.

ABSOLUTE MAXIMUM RATINGS (above which the useful life may be impaired)

Storage Temperature	-65°C to +150°C
Temperature (Ambient) Under Bias	-55°C to +125°C
V _{CC} Pin Potential to Ground Pin	-0.5 V to +7.0 V
*Input Voltage (dc)	-0.5 V to +5.5 V
*Input Current (dc)	-30 mA to +5.0 mA
Voltage Applied to Outputs (Output HIGH)	-0.5 V to +V _{CC} value
Output Current (dc) (Output LOW)	+30 mA

*Either Input Voltage limit or Input Current limit is sufficient to protect the inputs.

RECOMMENDED OPERATING CONDITIONS

PARAMETER	9392XM/5492XM			9392XC/7492XC			UNITS
	MIN.	TYP.	MAX.	MIN.	TYP.	MAX.	
Supply Voltage V _{CC} (Note 4)	4.5	5.0	5.5	4.75	5.0	5.25	Volts
Operating Free-Air Temperature Range	-55	25	125	0	25	70	°C
Normalized Fan Out from Each Output, N (Note 5)			10			10	U.L.
Width of Input Count Pulse, t _{p(in)}	50			50			ns
Width of Reset Pulse, t _{p(reset)}	50			50			ns

X = package type; F for Flatpak, D for Ceramic Dip, P for Plastic Dip. See Packaging Information Section for packages available on this product.

ELECTRICAL CHARACTERISTICS OVER OPERATING TEMPERATURE RANGE (unless otherwise noted)

SYMBOL	PARAMETER	LIMITS			UNITS	TEST CONDITIONS (Note 1)	TEST FIGURE
		MIN.	TYP. (Note 2)	MAX.			
V _{IH}	Input HIGH Voltage	2.0			Volts	Guaranteed V _{IH}	1
V _{IL}	Input LOW Voltage			0.8	Volts	Guaranteed V _{IL}	2
V _{OH}	Output HIGH Voltage	2.4			Volts	V _{CC} = MIN., I _{OH} = -0.4 mA	2
V _{OL}	Output LOW Voltage			0.4	Volts	V _{CC} = MIN., I _{OL} = 16 mA	1
I _{IH}	Input HIGH Current at R _{O(1)} or R _{O(2)} Inputs			40	μA	V _{CC} = MAX., V _{IN} = 2.4 V	3
				1.0	mA	V _{CC} = MAX., V _{IN} = 5.5 V	
	Input HIGH Current at Input \overline{CP}_A			80	μA	V _{CC} = MAX., V _{IN} = 2.4 V	3
				1.0	mA	V _{CC} = MAX., V _{IN} = 5.5 V	
Input HIGH Current at Input \overline{CP}_{BC}			160	μA	V _{CC} = MAX., V _{IN} = 2.4 V	3	
			1.0	mA	V _{CC} = MAX., V _{IN} = 5.5 V		
I _{IL}	Input LOW Current at R _{O(1)} or R _{O(2)} Inputs			-1.6	mA	V _{CC} = MAX., V _{IN} = 0.4 V	4
	Input LOW Current at Input \overline{CP}_A			-3.2	mA	V _{CC} = MAX., V _{IN} = 0.4 V	4
	Input LOW Current at Input \overline{CP}_{BC}			-6.4	mA	V _{CC} = MAX., V _{IN} = 0.4 V	4
I _{OS}	Output Short Circuit Current (Note 3)	-20		-57	mA	9392/5492 V _{CC} = MAX.	5
		-18		-57	mA	9392/7492 V _{OUT} = 0 V	
I _{CC}	Supply Current		31	44	mA	9392/5492 V _{CC} = MAX.	3
			31	51	mA	9392/7492 V _{IN} = 4.5 V	

SWITCHING CHARACTERISTICS (T_A = 25°C)

SYMBOL	PARAMETER	LIMITS			UNITS	TEST CONDITIONS	TEST FIGURE
		MIN.	TYP.	MAX.			
f _{max}	Maximum Frequency of Input Count Pulse	10	18		MHz	V _{CC} = 5.0 V C _L = 15 pF R _L = 400Ω	
t _{PLH}	Turn Off Delay from Input Count Pulse to Output Q _D		60	100	ns		A
t _{PHL}	Turn On Delay from Input Count Pulse to Output Q _D		60	100	ns		A

NOTES:

- (1) For conditions shown as MIN. or MAX., use the appropriate value specified under recommended operating conditions for the applicable circuit type.
- (2) Typical limits are at V_{CC} = 5.0 V, 25°C.
- (3) Not more than one output should be shorted at a time.
- (4) These voltage values are with respect to network ground terminal.
- (5) Fan-out from output Q_A to input \overline{CP}_{BC} and to 10 additional series 54/74 loads is permitted.

PARAMETER MEASUREMENT INFORMATION

DC TEST CIRCUIT*

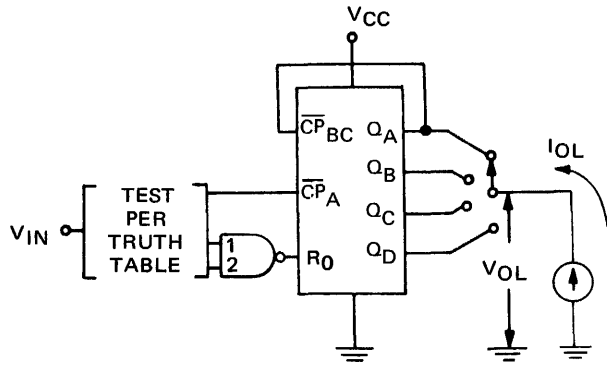

1. Each output is tested in the LOW level state.

Fig. 1

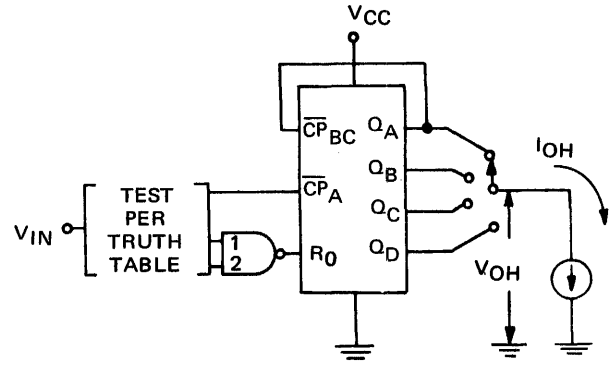

1. Each output is tested in the HIGH level state.

Fig. 2

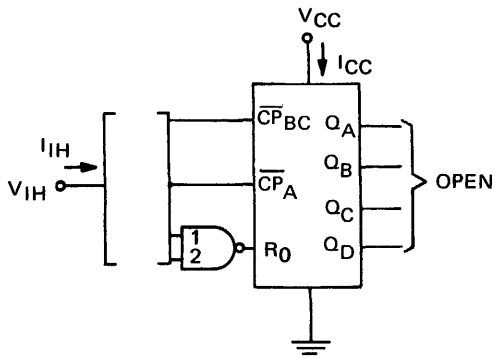

1. Each input is tested separately.
2. When testing R0(1) ground R0(2).
3. When testing R0(2) ground R0(1).
4. When testing ICC reset all outputs to LOW level, ground all inputs, then measure ICC.

Fig. 3

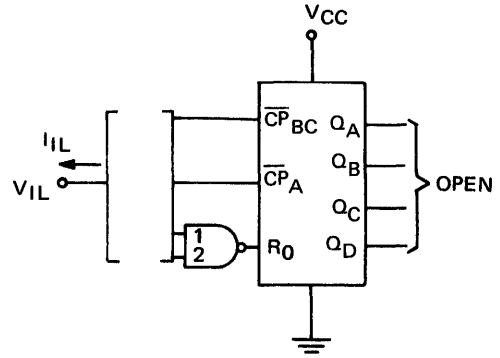

1. Each input is tested separately.
2. When testing R0(1) apply 4.5 V to R0(2).
3. When testing R0(2) apply 4.5 V to R0(1).

Fig. 4

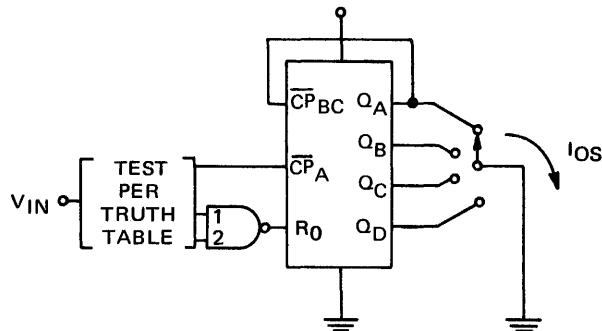

1. Each output is tested in the HIGH level state.

Fig. 5

*Arrows indicate actual direction of current flow.

PARAMETER MEASUREMENT INFORMATION (Con't.)

SWITCHING CHARACTERISTICS

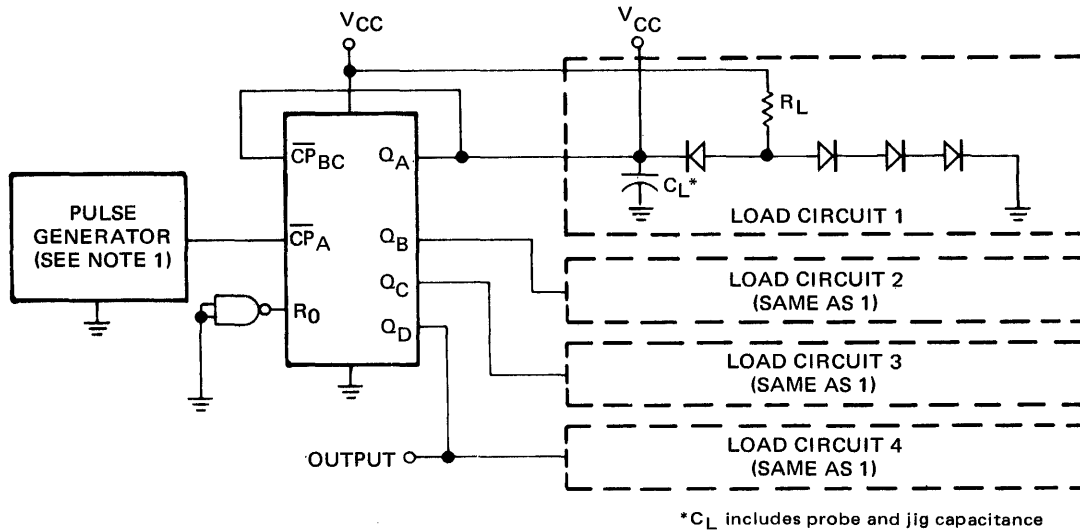

TEST CIRCUIT

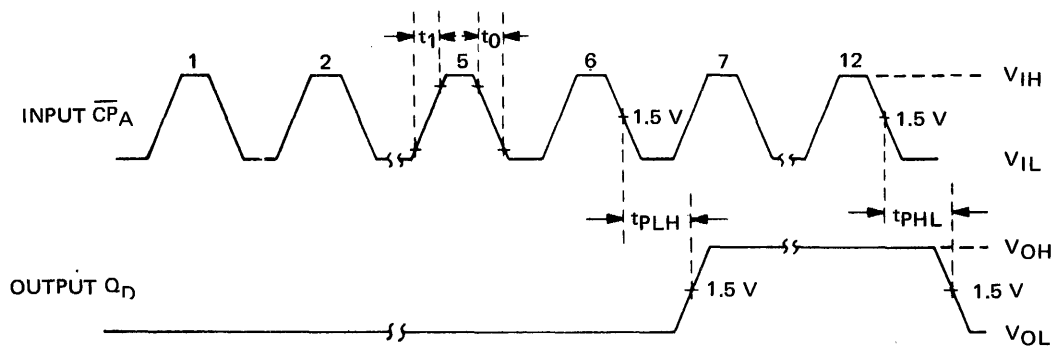

VOLTAGE WAVEFORMS

NOTES:

1. The pulse generator has the following characteristics: $V_{gen} = 3\text{ V}$, $t_0 = t_1 \leq 15\text{ ns}$, $t_p = 0.5\text{ }\mu\text{s}$, $PRR = 1\text{ MHz}$, $Z_{out} \approx 50\text{ }\Omega$.

2. Propagation delay = $\frac{t_{PLH} + t_{PLH}}{2}$

3. Voltage values are with respect to ground terminal.

Fig. A – SWITCHING TIMES

TTL/MSI 9393/5493, 7493

4-BIT BINARY COUNTER

DESCRIPTION – The TTL/MSI 9393/5493, 7493 is a 4-Bit Binary Counter consisting of four master/slave flip-flops which are internally interconnected to provide a divide-by-two counter and a divide-by-eight counter. A gated direct reset line is provided which inhibits the count inputs and simultaneously returns the four flip-flop outputs to a LOW level. As the output from flip-flop A is not internally connected to the succeeding flip-flops the counter may be operated in two independent modes:

1. When used as a 4-bit ripple-through counter, output Q_A must be externally connected to input \overline{CP}_B . The input count pulses are applied to input \overline{CP}_A . Simultaneously divisions of 2, 4, 8 and 16 are performed at the Q_A , Q_B , Q_C , and Q_D outputs as shown in the truth table.
2. When used as a 3-bit ripple-through counter, the input count pulses are applied to input \overline{CP}_B . Simultaneous frequency divisions of 2, 4, and 8 are available at the Q_B , Q_C , and Q_D outputs. Independent use of flip-flop A is available if the reset function coincides with reset of the 3-bit ripple-through counter.

These circuits are completely compatible with TTL and DTL logic families.

PIN NAMES

R_0
 \overline{CP}_A
 \overline{CP}_B
 Q_A, Q_B, Q_C, Q_D

Reset-Zero Input
 Clock (Active LOW going edge) Input
 Clock (Active LOW going edge) Input
 Outputs

LOADING

1 U.L.
 2 U.L.
 2 U.L.
 10 U.L.

TRUTH TABLE (See Notes 1, 2 and 3)

COUNT	OUTPUT			
	Q_D	Q_C	Q_B	Q_A
0	L	L	L	L
1	L	L	L	H
2	L	L	H	L
3	L	L	H	H
4	L	H	L	L
5	L	H	L	H
6	L	H	H	L
7	L	H	H	H
8	H	L	L	L
9	H	L	L	H
10	H	L	H	L
11	H	L	H	H
12	H	H	L	L
13	H	H	L	H
14	H	H	H	L
15	H	H	H	H

1 Unit Load (U.L.) = 40 μ A HIGH/1.6 mA LOW

NOTES:

1. Output Q_A connected to input \overline{CP}_B .
2. To reset all outputs to LOW level both $R_0(1)$ and $R_0(2)$ inputs must be at HIGH level state.
3. Either (or both) reset inputs $R_0(1)$ and $R_0(2)$ must be at a LOW level to count.

LOGIC DIAGRAM

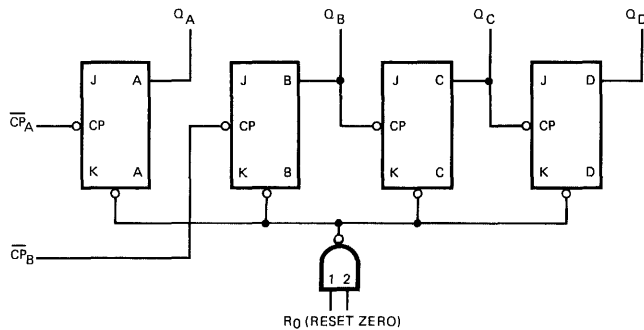

LOGIC SYMBOL

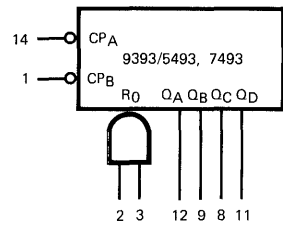

V_{CC} = Pin 5
 GND = Pin 10
 N.C. = Pins 4, 6, 7, 13

CONNECTION DIAGRAMS DIP (TOP VIEW)

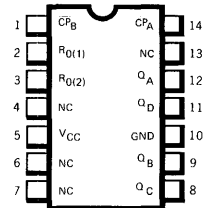

FLATPAK (TOP VIEW)

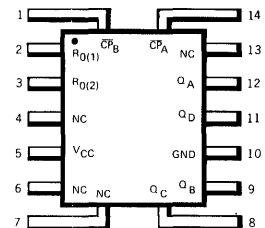

NC – No Internal Connection
 Positive logic: See Truth Table

TTL/MSI • 9393/5493, 7493

ABSOLUTE MAXIMUM RATINGS (above which the useful life may be impaired)

Storage Temperature	-65°C to +150°C
Temperature (Ambient) Under Bias	-55°C to +125°C
V _{CC} Pin Potential to Ground Pin	-0.5 V to +7.0 V
*Input Voltage (dc)	-0.5 V to +5.5 V
*Input Current (dc)	-30 mA to +5.0 mA
Voltage Applied to Outputs (Output HIGH)	-0.5 V to +V _{CC} value
Output Current (dc) (Output LOW)	+30 mA

*Either Input Voltage limit or Input Current limit is sufficient to protect the inputs.

RECOMMENDED OPERATING CONDITIONS

PARAMETER	9393XM/5493XM			9393XC/7493XC			UNITS
	MIN.	TYP.	MAX.	MIN.	TYP.	MAX.	
Supply Voltage V _{CC} (Note 4)	4.5	5.0	5.5	4.75	5.0	5.25	Volts
Operating Free-Air Temperature Range	-55	25	125	0	25	70	°C
Normalized Fan-Out from Each Output, N (Note 5)			10			10	U.L.
Width of Input Count Pulse, t _{p(in)}	50			50			ns
Width of Reset Pulse, t _{p(reset)}	50			50			ns

X=package type; F for Flatpak, D for Ceramic Dip, P for Plastic Dip. See Packaging Information Section for packages available on this product

ELECTRICAL CHARACTERISTICS OVER OPERATING TEMPERATURE RANGE (Unless Otherwise Noted)

SYMBOL	PARAMETER	LIMITS			UNITS	TEST CONDITIONS (Note 1)	TEST FIGURE	
		MIN.	TYP. (Note 2)	MAX.				
V _{IH}	Input HIGH Voltage	2.0			Volts		1	
V _{IL}	Input LOW Voltage			0.8	Volts		2	
V _{OH}	Output HIGH Voltage	2.4			Volts	V _{CC} = MIN., I _{OH} = -0.4 mA	2	
V _{OL}	Output LOW Voltage			0.4	Volts	V _{CC} = MIN., I _{OL} = 16 mA	1	
I _{IH}	Input HIGH Current at R _{O(1)} or R _{O(2)} Inputs			40	μA	V _{CC} = MAX., V _{IN} = 2.4 V	3	
				1.0	mA	V _{CC} = MAX., V _{IN} = 5.5 V		
	Input HIGH Current at Inputs \overline{CP}_A or \overline{CP}_B			80	μA	V _{CC} = MAX., V _{IN} = 2.4 V	3	
I _{IL}	Input LOW Current at R _{O(1)} or R _{O(2)} Inputs			1.0	mA	V _{CC} = MAX., V _{IN} = 5.5 V	4	
				-1.6	mA	V _{CC} = MAX., V _{IN} = 0.4 V		
	Input LOW Current at Inputs \overline{CP}_A or \overline{CP}_B			-3.2	mA	V _{CC} = MAX., V _{IN} = 0.4 V	4	
I _{OS}	Output Short Circuit Current (Note 3)	-20		-57	mA	9393/5493	V _{CC} = MAX. V _{OUT} = 0 V	5
		-18		-57	mA	9393/7493		
I _{CC}	Supply Current		32	46	mA	9393/5493	V _{CC} = MAX. V _{IN} = 4.5 V	3
			32	53	mA	9393/7493		

SWITCHING CHARACTERISTICS (T_A = 25°C)

SYMBOL	PARAMETER	LIMITS			UNITS	TEST CONDITIONS	TEST FIGURE
		MIN.	TYP.	MAX.			
f _{max}	Maximum Frequency of Input Count Pulse	10	18		MHz	V _{CC} = 5.0 V C _L = 15 pF R _L = 400Ω	
t _{PLH}	Turn Off Delay from Input Count Pulse to Output Q _D		75	135	ns		A
t _{PHL}	Turn On Delay from Input Count Pulse to Output Q _D		75	135	ns		A

NOTES:

- (1) For conditions shown as MIN. or MAX., use the appropriate value specified under recommended operating conditions for the applicable circuit type.
- (2) Typical limits are at V_{CC} = 5.0 V, 25°C.
- (3) Not more than one output should be shorted at a time.
- (4) These voltage values are with respect to network ground terminal.
- (5) Fan-out from output Q_A to input \overline{CP}_B and to 10 additional series 54/74 loads is permitted.

PARAMETER MEASUREMENT INFORMATION

DC TEST CIRCUITS*

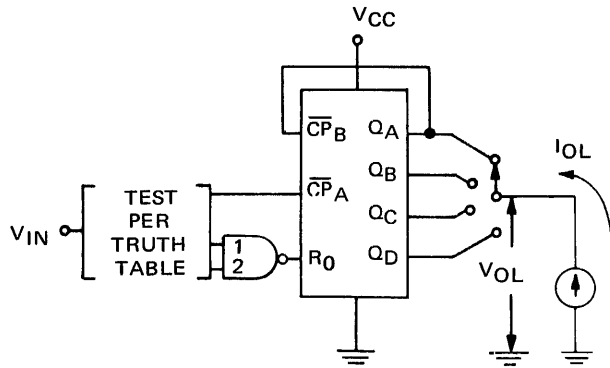

1. Each output is tested in the LOW level state.

Fig. 1

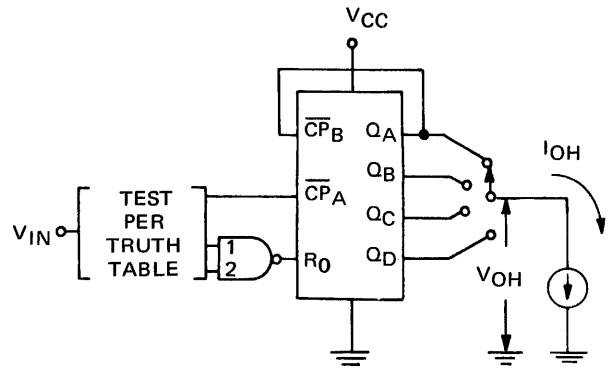

1. Each output is tested in the HIGH level state.

Fig. 2

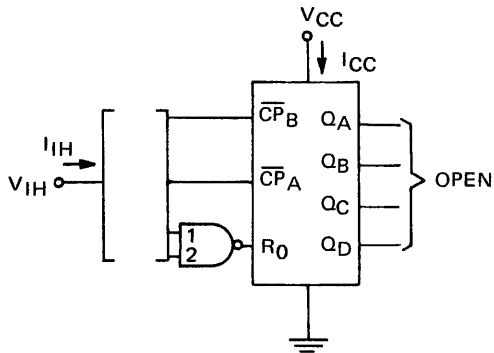

1. Each input is tested separately.
2. When testing R0(1) ground R0(2).
3. When testing R0(2) ground R0(1).
4. When testing ICC all inputs and outputs are open.

Fig. 3

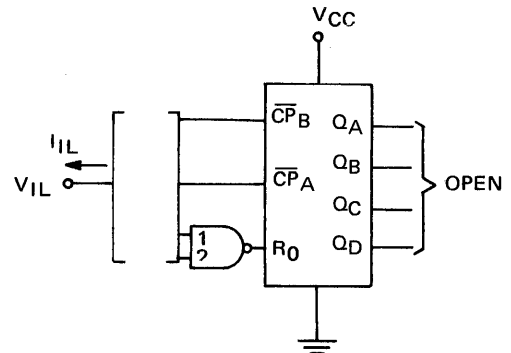

1. Each input is tested separately.
2. When testing R0(1) apply 4.5 V to R0(2).
3. When testing R0(2) apply 4.5 V to R0(1).

Fig. 4

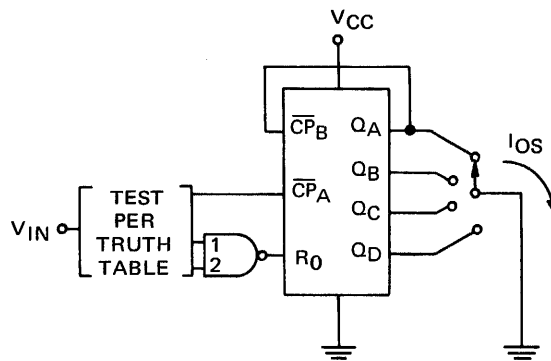

1. Each output is tested in the HIGH level state.

Fig. 5

* Arrows indicate actual direction of current flow.

PARAMETER MEASUREMENT INFORMATION (con't.)

SWITCHING CHARACTERISTICS

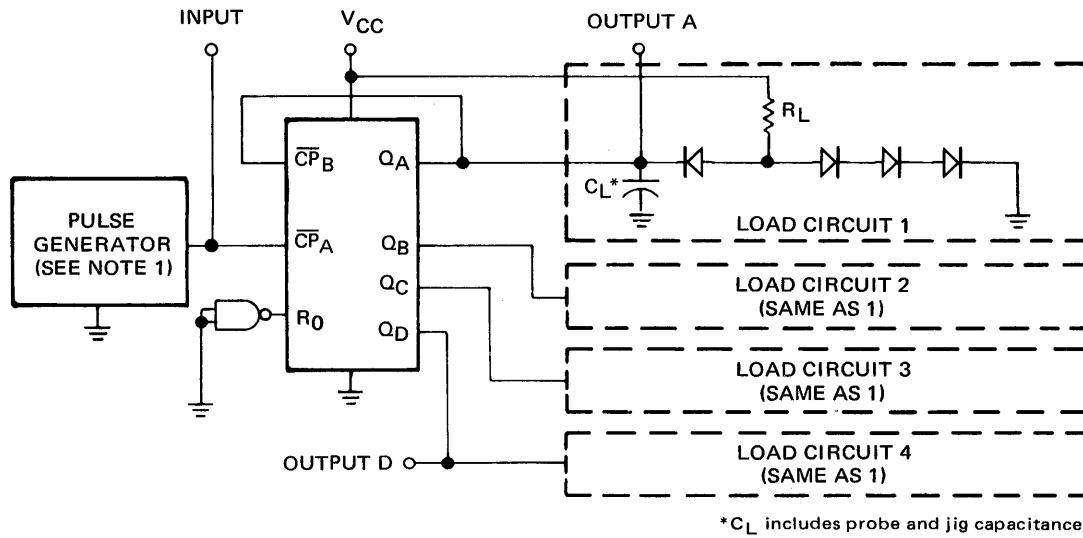

TEST CIRCUIT

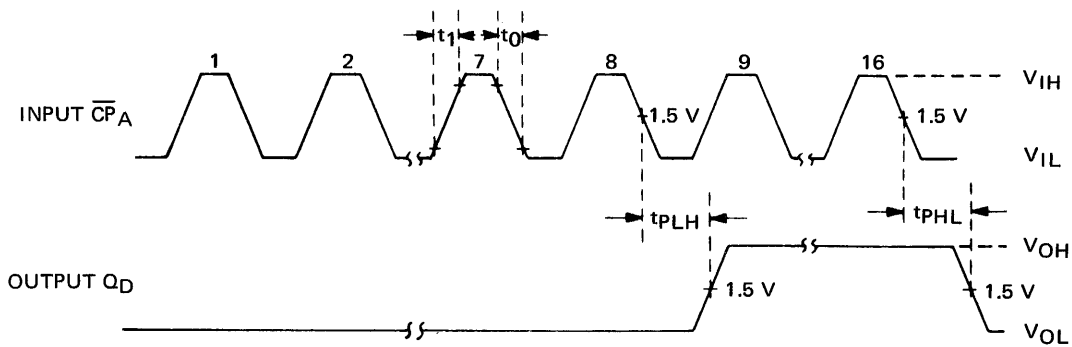

VOLTAGE WAVEFORMS

1. The pulse generator has the following characteristics: $V_{gen} = 3\text{ V}$, $t_0 = t_1 \leq 15\text{ ns}$, $t_p = 0.5\text{ }\mu\text{s}$, $PRR = 1\text{ MHz}$, $Z_{out} \approx 50\Omega$.
2. Propagation delay = $\frac{t_{PLH} + t_{PLH}}{2}$
3. Voltage values are with respect to ground terminal.

Fig. A - SWITCHING TIMES

TTL/MSI 9394/5494, 7494

4-BIT SHIFT REGISTER

DESCRIPTION – The TTL/MSI 9394/5494, 7494 is composed of four RS master/slave flip-flops, four AND-OR-INVERT gates and four inverter-drivers. Internal interconnections of these functions provide a versatile register which performs right-shift operations as a serial-in, serial-out register or as a dual-source, parallel-to-serial converter. A number of these registers may be connected in series to form an n-bit register.

All flip-flops are simultaneously set to the LOW state by applying a HIGH level voltage to the clear input. This condition may be applied independent of the state of the clock input, but not independent of state of the preset input. Preset input is independent of the clock and clear states.

The flip-flops are simultaneously set to the HIGH state from either of two preset input sources. Preset inputs P_{1A} through P_{1D} are activated during the time that a positive pulse is applied to preset 1 if preset 2 is at a LOW level. When the logic levels at preset 1 and preset 2 are reversed, preset inputs P_{2A} through P_{2D} are active.

Transfer of information to the outputs occurs when the clock input goes from a LOW to a HIGH level. Since the flip-flops are RS master/slave circuits, the proper information must appear at the RS inputs of each flip-flop prior to the rising edge of the clock input waveform. The serial input provides this information for the first flip-flop. The outputs of the subsequent flip-flops provide information for the remaining RS inputs. The clear input, preset 1, and preset 2 must be at a LOW state when clocking occurs.

ABSOLUTE MAXIMUM RATINGS (above which the useful life may be impaired)

Storage Temperature	-65°C to +150°C
Temperature (Ambient) Under Bias	-55°C to +125°C
V _{CC} Pin Potential to Ground Pin	-0.5 V to +7.0 V
*Input Voltage (dc)	-0.5 V to +5.5 V
*Input Current (dc)	-30 mA to +5.0 mA
Voltage Applied to Outputs (Output HIGH)	-0.5 V to +V _{CC} value
Output Current (dc) (Output LOW)	+30 mA

*Either Input Voltage limit or Input Current limit is sufficient to protect the inputs.

PIN NAMES

P _{1A} – P _{2D}	Preset Inputs
PL ₁	Preset 1 Input
PL ₂	Preset 2 Input
D _S	Serial Data Inputs
CP	Clock Input
C _L	Clear Input
Q _D	Serial Data Output

LOADING

1 U.L.
4 U.L.
4 U.L.
1 U.L.
1 U.L.
1 U.L.
10 U.L.

1 Unit Load (U.L.) = 40μA HIGH/1.6mA LOW.

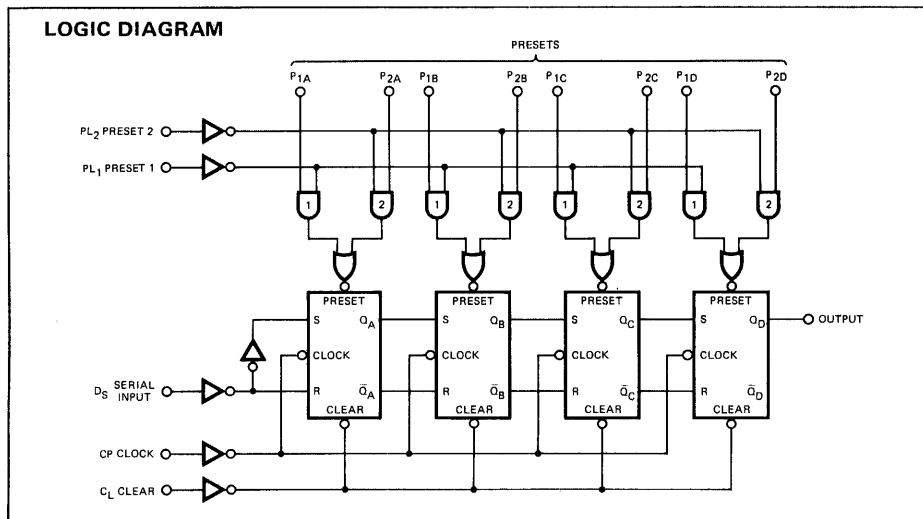

LOGIC SYMBOL

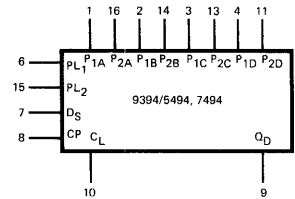

V_{CC} = Pin 5
GND = Pin 12

**CONNECTION DIAGRAM
DIP (TOP VIEW)**

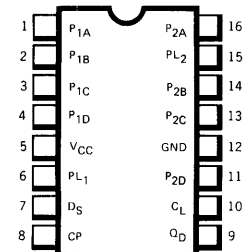

FLAT PAK (TOP VIEW)

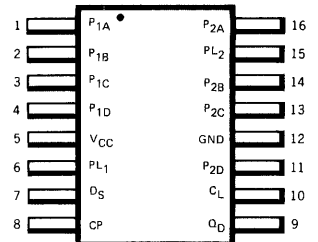

Positive Logic: HIGH input to clear sets Q_A, Q_B, Q_C and Q_D to LOW level.

FAIRCHILD TTL/MSI • 9394/5494, 7494

TRUTH TABLE

CLOCK INPUT	CLEAR INPUT	COMMON PRESETS		BIT PRESETS		Q _D
		1	2	1A-1D	2A-2D	
X	H	L	L	Inhibit	Inhibit	L
X	X	H	L	Active	Inhibit	Follows 1D
X	X	L	H	Inhibit	Active	Follows 2D
Active	L	L	L	Inhibit	Inhibit	Follows Serial Input by 4 Bits

Common Presets (PL₁, PL₂) not activated (H) simultaneously X-either H or L.

States of internal Flip-Flops Q_A, Q_B, Q_C, will follow either 1A - 1C or 2A - 2C depending upon common preset condition.

Serial input is overridden except when clocking.

RECOMMENDED OPERATING CONDITIONS

PARAMETER	9394XM/5494XM			9394XC/7494XC			UNITS
	MIN.	TYP.	MAX.	MIN.	TYP.	MAX.	
Supply Voltage V _{CC} (See Note 4)	4.5	5.0	5.5	4.75	5.0	5.5	Volts
Operating Free-Air Temperature Range	-55	25	125	0	25	70	°C
Normalized Fan Out from Output			10			10	U.L.
Width of Clock Pulse, t _{p(clock)}	35			35			ns
Width of Preset Pulse, t _{p(preset)}	30			30			ns
Width of Clear Pulse, t _{p(clear)}	30			30			ns
Serial Input Setup Time,	t _{setup} (HIGH)	35		35			ns
	t _{setup} (LOW)	25		25			ns
Serial Input Hold Time, t _{hold}	0			0			

X = package type; F for Flatpak, D for Ceramic Dip, P for Plastic Dip. See Packaging Information Section for packages available on this product.

ELECTRICAL CHARACTERISTICS OVER OPERATING TEMPERATURE RANGE (Unless Otherwise Noted)

SYMBOL	PARAMETER	LIMITS			UNITS	TEST CONDITIONS (Note 1)
		MIN.	TYP. (Note 2)	MAX.		
V _{IH}	Input HIGH Voltage	2.0			Volts	Guaranteed V _{IH}
V _{IL}	Input LOW Voltage			0.8	Volts	Guaranteed V _{IL}
V _{OH}	Output HIGH Voltage	2.4	3.5		Volts	V _{CC} = MIN., I _{OH} = -0.4 mA
V _{OL}	Output LOW Voltage		0.22	0.4	Volts	V _{CC} = MIN., I _{OL} = 16 mA
I _{IH}	Input HIGH Current at Any Input Except Preset 1 and Preset 2			40	μA	V _{CC} = MAX., V _{IN} = 2.4 V
				1.0	mA	V _{CC} = MAX., V _{IN} = 5.5 V
	Input HIGH Current at Preset 1 and Preset 2			160	μA	V _{CC} = MAX., V _{IN} = 2.4 V
I _{IL}	Input LOW Current at Any Input Except Preset 1 and Preset 2			-1.6	mA	V _{CC} = MAX., V _{IN} = 0.4 V
				-6.4	mA	V _{CC} = MAX., V _{IN} = 0.4 V
	Input LOW Current at Preset 1 and Preset 2					
I _{OS}	Output Short Circuit Current (Note 3)	-20		-57	mA	9394/5494
		-18		-57	mA	9394/7494
I _{CC}	Supply Current		35	50	mA	9394/5494
			35	58	mA	9394/7494

SWITCHING CHARACTERISTICS (T_A = 25°C)

SYMBOL	PARAMETER	LIMITS			UNITS	TEST CONDITIONS
		MIN.	TYP.	MAX.		
f _{max}	Maximum Clock Frequency	10			MHz	V _{CC} = 5.0 V C _L = 15 pF R _L = 400Ω
t _{PLH}	Turn Off Delay Clock to Output		25	40	ns	
t _{PHL}	Turn On Delay Clock to Output		25	40	ns	
t _{PLH}	Turn Off Delay Preset to Output			35	ns	
t _{PHL}	Turn On Delay Clear to Output			40	ns	

NOTES:

- (1) For conditions shown as MIN. or MAX., use the appropriate value specified under recommended operating conditions for the applicable circuit type.
- (2) Typical limits are at V_{CC} = 5.0 V, 25°C.
- (3) Not more than one output should be shorted at a time.
- (4) These voltage values are with respect to network ground terminal.

TTL/MSI 9395/5495, 7495

4-BIT RIGHT-SHIFT, LEFT-SHIFT REGISTER

DESCRIPTION – The TTL/MSI 9395/5495, 7495 Shift Register is composed of four RS master/slave flip-flops, four AND-OR-INVERT gates, one AND-OR gate and six inverters-drivers. Internal interconnections of these functions provide a versatile register which will perform right-shift or left-shift operations dependent upon the logic input level to the mode control. A number of these registers may be connected in series to form an n-bit right-shift or left-shift register. This register can also be used as a parallel-in, parallel-out storage register with gate (mode) control.

When a LOW level is applied to the mode control input, the number 1 AND gates are enabled and the number-2 AND gates are inhibited. In this mode the output of each flip-flop is coupled to the RS inputs of the succeeding flip-flop and right-shift operation is performed by clocking at the clock 1 input. In this mode, serial data is entered at the serial input. Clock 2 and parallel inputs A through D are inhibited by the number 2 AND gates.

When a HIGH level is applied to the mode control input, the number 1 AND gates are inhibited (decoupling the outputs from the succeeding RS inputs to prevent right-shift) and the number 2 AND gates are enabled to allow entry of data through parallel inputs A through D and clock 2. This mode permits parallel loading of the register, or with external interconnection, shift-left operation. In this mode, shift-left can be accomplished by connecting the output of each flip-flop to the parallel input of the previous flip-flop (Q_D to input C, and etc.), and serial data is entered at input D.

Clocking for the shift register is accomplished through the AND-OR gate E which permits separate clock sources to be used for the shift-right and shift-left modes. If both modes can be clocked from the same source, the clock input may be applied commonly to clock 1 and clock 2. Information must be present at the R-S inputs of the master-slave flip-flops prior to clocking. Transfer of information to the output pins occurs when the clock input goes from a HIGH to a LOW level.

PIN NAMES

\overline{CP}_1
 \overline{CP}_2
 M
 P_A, P_B, P_C, P_D
 Q_A, Q_B, Q_C, Q_D
 D_S

Clock 1 Input
 Clock 2 Input
 Mode Control Input
 Parallel Data Inputs
 Parallel Data Outputs
 Serial Data Input

LOADING

1 U.L.
 1 U.L.
 2 U.L.
 1 U.L.
 10 U.L.
 1 U.L.

1 Unit Load (U.L.) = 40 μ A HIGH / 1.6 mA LOW

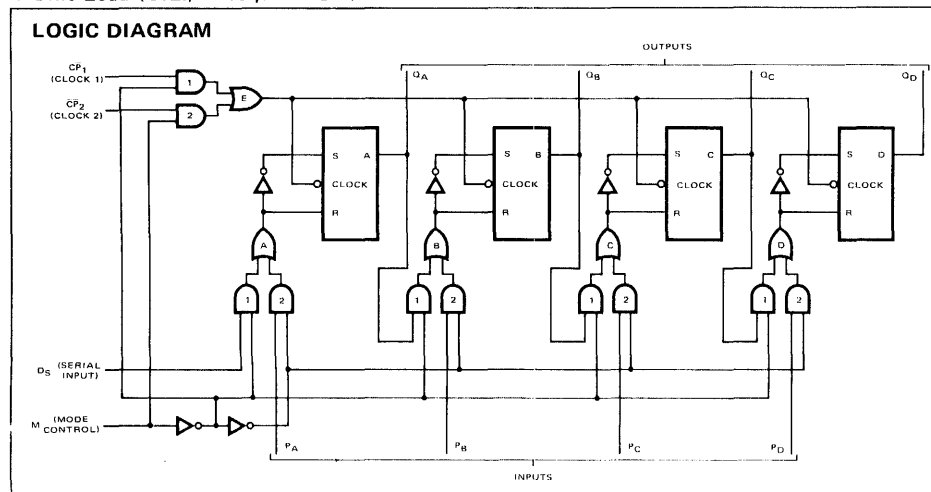

LOGIC SYMBOL

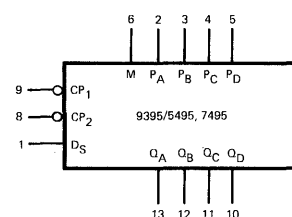

V_{CC} = Pin 14
 GND = Pin 7

CONNECTION DIAGRAM DIP (TOP VIEW)

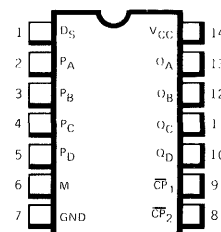

FLATPAK (TOP VIEW)

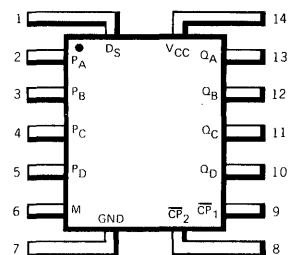

Positive logic:
 Mode control = LOW for right shift
 Mode control = HIGH for left shift
 or parallel load

ABSOLUTE MAXIMUM RATINGS (above which the useful life may be impaired)

Storage Temperature	-65°C to +150°C
Temperature (Ambient) Under Bias	-55°C to +125°C
V _{CC} Pin Potential to Ground Pin	-0.5 V to +7.0 V
*Input Voltage (dc)	-0.5 V to +5.5 V
*Input Current (dc)	-30 mA to +5.0 mA
Voltage Applied to Outputs (Output HIGH)	-0.5 V to +V _{CC} value
Output Current (dc) (Output LOW)	+30 mA

*Either Input Voltage limit or Input Current limit is sufficient to protect the inputs.

RECOMMENDED OPERATING CONDITIONS

PARAMETER	9395XM/5495XM			9395XC/7495XC			UNITS
	MIN	TYP	MAX	MIN	TYP	MAX	
Supply Voltage V _{CC} (See Note 4)	4.5	5.0	5.5	4.75	5.0	5.25	Volts
Operating Free-Air Temperature Range	-55	25	125	0	25	70	°C
Normalized Fan Out from Each Output	HIGH Level			20			U.L.
	LOW Level			10			
Width of Clock Pulse t _{p(clock)} (See Fig. A)	20	10		15	10		ns
Setup Time Required at Serial, A, B, C, or D Inputs t _{setup} (See Fig. A)	10			10			ns
Hold Time Required at Serial, A, B, C, or D Inputs t _{hold} (See Fig. A)	0			0			ns
LOW Level Setup Time Required at Mode Control (t ₁ in Fig. B) (With Respect to Clock 1 Input)	15			15			ns
HIGH Level Setup Time Required at Mode Control (t ₂ in Fig. B) (With Respect to Clock 2 Input)	15			15			ns
LOW Level Setup Time Required at Mode Control (t ₃ in Fig. B) (With Respect to Clock 2 Input)	5.0			5.0			ns
HIGH Level Setup Time Required at Mode Control (t ₄ in Fig. B) (With Respect to Clock 1 Input)	5.0			5.0			ns

X = package type; F for Flatpak, D for Ceramic Dip, P for Plastic Dip. See Packaging Information Section for packages available on this product.

ELECTRICAL CHARACTERISTICS OVER OPERATING TEMPERATURE RANGE (Unless Otherwise Noted)

SYMBOL	PARAMETER	LIMITS			UNITS	TEST CONDITIONS (Note 1)	TEST FIGURE
		MIN.	TYP. (Note 2)	MAX.			
V _{IH}	Input HIGH Voltage	2.0			Volts	Guaranteed V _{IH}	1 & 3
V _{IL}	Input LOW Voltage			0.8	Volts	Guaranteed V _{IL}	2 & 4
V _{OH}	Output HIGH Voltage	2.4			Volts	V _{CC} = MIN., I _{OH} = -0.8 mA	1 & 3
V _{OL}	Output LOW Voltage			0.4	Volts	V _{CC} = MIN., I _{OL} = 16 mA	2 & 4
I _{IH}	Input HIGH Current at Any Input Except Mode Control			40	μA	V _{CC} = MAX., V _{IN} = 2.4 V	6
	Input HIGH Current at Mode Control			1.0	mA	V _{CC} = MAX., V _{IN} = 2.4 V	
	Input HIGH Current at Mode Control			80	μA	V _{CC} = MAX., V _{IN} = 2.4 V	6
I _{IL}	Input LOW Current at Any Input Except Mode Control			-1.6	mA	V _{CC} = MAX., V _{IN} = 0.4 V	5
	Input LOW Current at Mode Control			-3.2	mA	V _{CC} = MAX., V _{IN} = 0.4 V	5
I _{OS}	Output Short Circuit Current (Note 3)	-18		-57	mA	V _{CC} = MAX.	7
I _{CC}	Supply Current	39		63	mA	V _{CC} = MAX.	8

NOTES:

- (1) For conditions shown as MIN. or MAX., use the appropriate value specified under recommended operating conditions for the applicable circuit type.
- (2) Typical limits are at V_{CC} = 5.0 V, 25°C.
- (3) Not more than one output should be shorted at a time.
- (4) Voltage values are with respect to network ground terminal.

SWITCHING CHARACTERISTICS ($T_A = 25^\circ\text{C}$)

SYMBOL	PARAMETER	LIMITS			UNITS	TEST CONDITIONS	TEST FIGURE
		MIN.	TYP.	MAX.			
f_{max}	Maximum Clock Frequency	25	36		MHz	$V_{\text{CC}} = 5.0\text{ V}$ $C_L = 15\text{ pF}$ $R_L = 400\Omega$	A
t_{PLH}	Turn Off Delay Clock 1 or Clock 2 to Outputs		18	27	ns		A
t_{PHL}	Turn On Delay Clock 1 or Clock 2 to Outputs		21	32	ns		A

PARAMETER MEASUREMENT INFORMATION

DC TEST CIRCUITS*

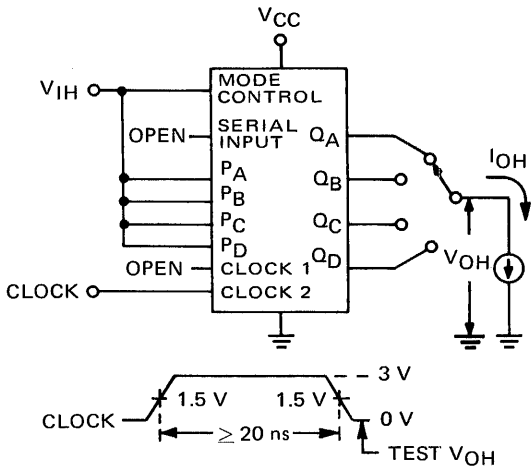

Fig. 1

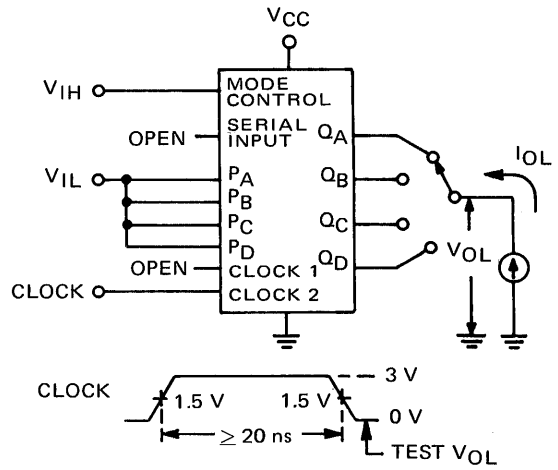

Fig. 2

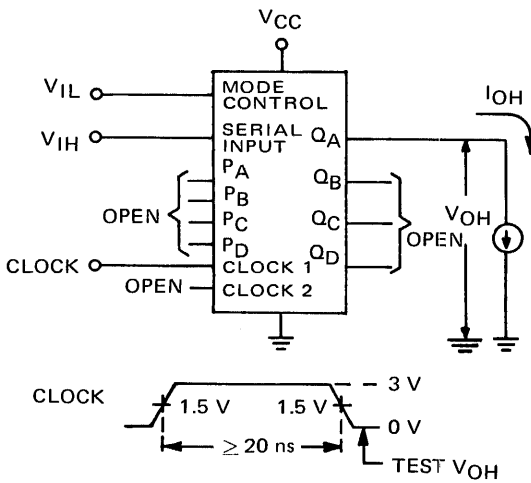

Fig. 3

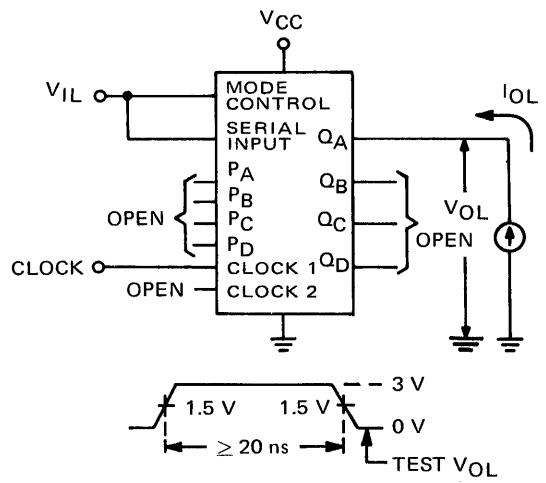
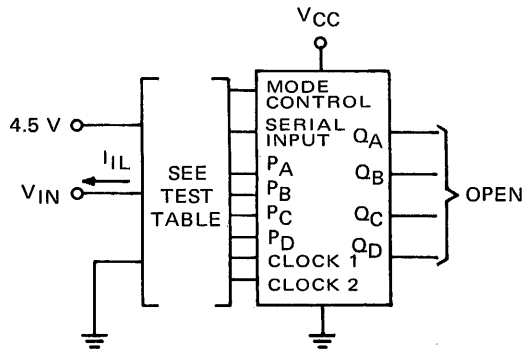

Fig. 4

*Arrows indicate actual direction of current flow.

PARAMETER MEASUREMENT INFORMATION (con't.)

DC TEST CIRCUITS*(Continued)



1. Each Input is tested separately.

Fig. 5

TEST TABLE

Test	Apply 4.5 V	Apply GND
Mode Control	Clock 2	None
Serial Input	None	Mode Control
Input P _A	Mode Control	None
Input P _B	Mode Control	None
Input P _C	Mode Control	None
Input P _D	Mode Control	None
Clock 1	None	Mode Control
Clock 2	Mode Control	None

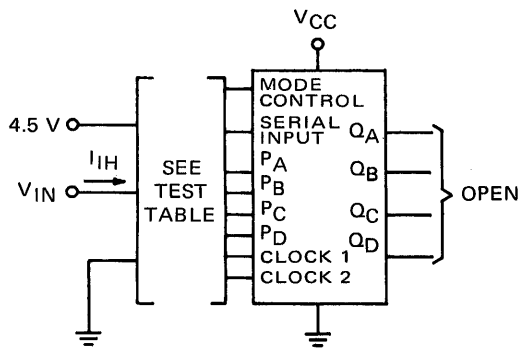

Fig. 6

TEST TABLE

Test	Apply 4.5 V	Apply GND
Mode Control	None	Clock 2
Serial Input	Mode Control	None
Input P _A	None	Mode Control
Input P _B	None	Mode Control
Input P _C	None	Mode Control
Input P _D	None	Mode Control
Clock 1	Mode Control	None
Clock 2	None	Mode Control

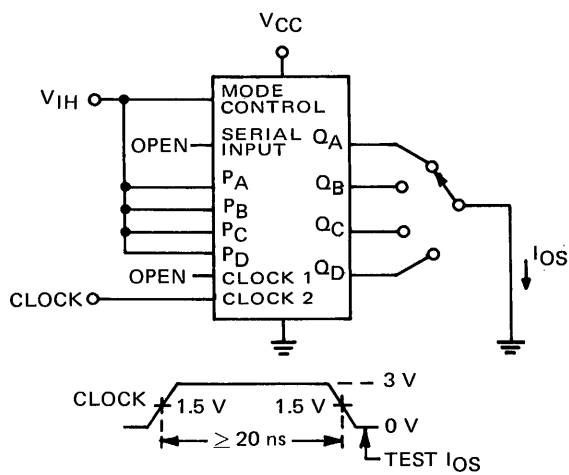

Fig. 7

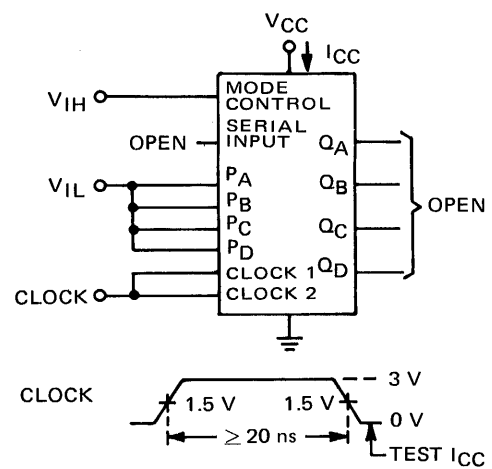
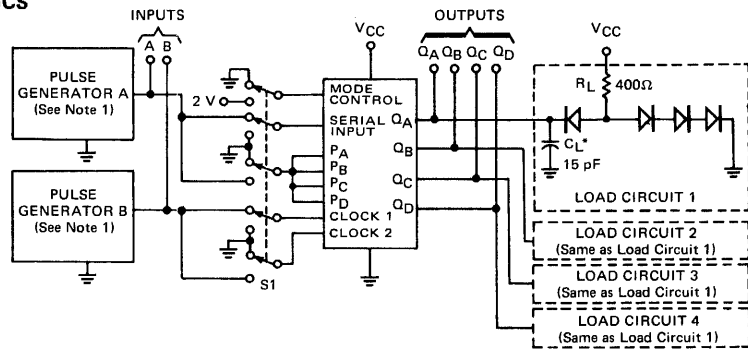

Fig. 8

*Arrows indicate actual direction of current flow.

PARAMETER MEASUREMENT INFORMATION (con't.)

SWITCHING CHARACTERISTICS



*CL includes probe and jig capacitance.

TEST CIRCUIT

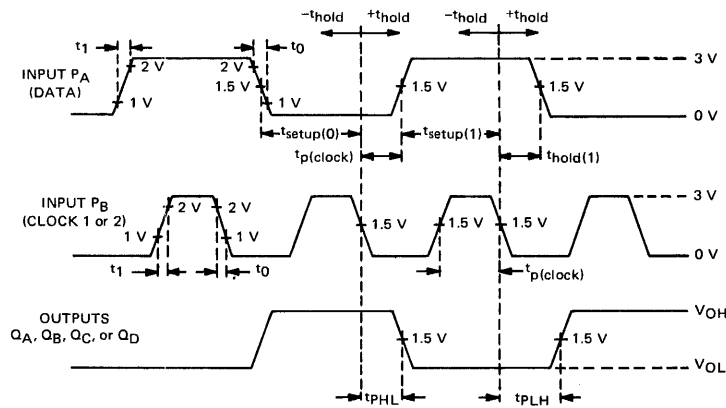

VOLTAGE WAVEFORMS

NOTES:

1. The pulse generators having the following characteristics: $V_{gen} = 3\text{ V}$, $t_1 = t_0 \leq 10\text{ ns}$, and $Z_{out} \approx 50\Omega$. For pulse generator A: $t_p \geq 20\text{ ns}$ and $PRR = 500\text{ kHz}$. For pulse generator B: $t_p \geq 15\text{ ns}$ and $PRR = 1\text{ MHz}$. When testing f_{max} vary PRR.
2. Voltage values are with respect to network ground terminal.

Fig. A SWITCHING TIMES

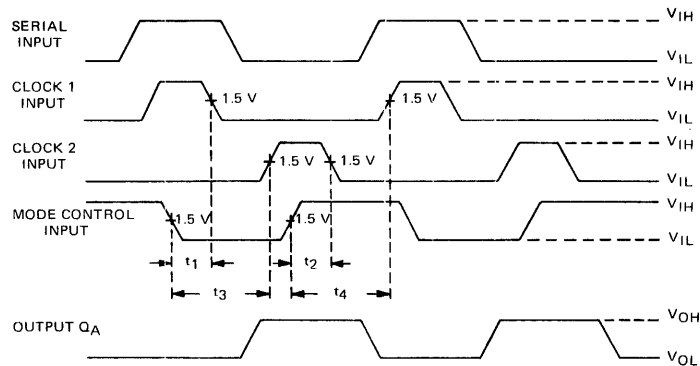

Note: Input PA is at VIL.

Fig. B RECOMMENDED MODE CONTROL SETUP TIMES

TTL/MSI 9396/5496, 7496

5-BIT SHIFT REGISTER

DESCRIPTION – The TTL/MSI 9396/5496, 7496 5-Bit Shift Register consists of five RS master/slave flip-flops connected to perform parallel-to-serial or serial-to-parallel conversion of binary data. Since both inputs and outputs to all flip-flops are accessible, parallel-in/parallel-out or serial-in/serial-out operation may be performed.

All flip-flops are simultaneously set to the LOW state by applying a low level voltage to the clear input. This condition may be applied independent of the state of the clock input.

The flip-flops may be independently set to the HIGH state by applying a high level voltage to both the preset input of the specific flip-flop and the common preset input. The parallel enable input is provided to allow setting each flip-flop independently or setting two or more flip-flops simultaneously. Preset is independent of the state of the clock input or clear input.

Transfer of information to the output pins occurs when the clock input goes from a LOW level to a HIGH level. Since the flip-flops are RS master/slave circuits, the proper information must appear at the RS inputs of each flip-flop prior to the rising edge of the clock input voltage waveform. The serial input provides this information to the first flip-flop, while the outputs of the subsequent flip-flops provide information for the remaining RS inputs. The clear input must be at a HIGH level and the preset input must be at a LOW level when clocking occurs.

PIN NAMES

PL	Parallel Load Input
P _A , P _B , P _C , P _D , P _E	Parallel Data Inputs
D _S	Serial Data Input
CP	Clock Input
C _L	Clear Input
Q _A , Q _B , Q _C , Q _D , Q _E	Parallel Data Outputs

LOADING

5 U.L.
1 U.L.
1 U.L.
1 U.L.
1 U.L.
10 U.L.

1 Unit Load (U.L.) = 40 μ A HIGH/1.6 mA LOW

TRUTH TABLE

PRESET COMMON	BIT	CLEAR	SERIAL INPUT	CLOCK	OUTPUT	
L	X	L	X	X	L	Clear all output to logical "L".
H	H	H	X	X	H	Preset outputs to 1 input bit configuration.
H	L	H	X	X	L	Serial input shift right.
L	X	H	H	enable	H	Serial-to-parallel conversion.
L	X	H	L	enable	L	

NOTES:

- After loading data, set clear to "H" and preset to "L" clock to give parallel to serial conversion.
- Information transferred on rising edge of clock pulse.



- Do not enable preset and clear simultaneously.

Preset – "H" Clear – "L" = undefined output. Dependent upon which enable is removed first.

- X Either logical "L" or logical "H".

LOGIC DIAGRAM

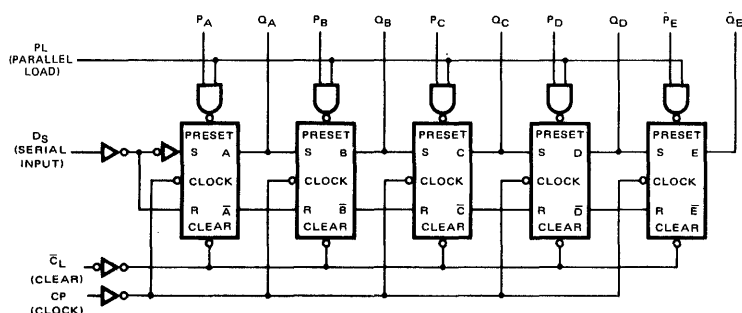

LOGIC SYMBOL

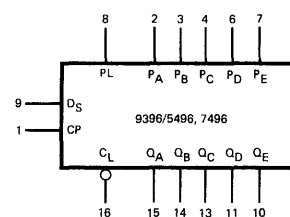

V_{CC} = Pin 5
GND = Pin 12

CONNECTION DIAGRAM DIP (TOP VIEW)

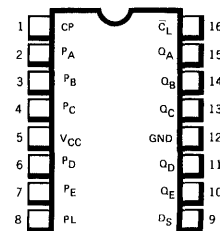

FLATPAK (TOP VIEW)

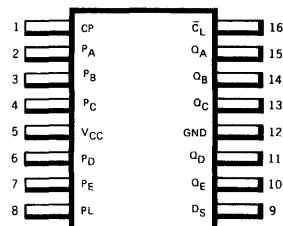

Positive Logic: LOW input at clear sets all outputs to LOW level.

TTL/MSI • 9396/5496, 7496

ABSOLUTE MAXIMUM RATINGS (above which the useful life may be impaired)

Storage Temperature	-65°C to +150°C
Temperature (Ambient) Under Bias	-55°C to +125°C
V _{CC} Pin Potential to Ground Pin	-0.5 V to +7.0 V
*Input Voltage (dc)	-0.5 V to +5.5 V
*Input Current (dc)	-30 mA to +5.0 mA
Voltage Applied to Outputs (Output HIGH)	-0.5 V to +V _{CC} value
Output Current (dc) (Output LOW)	+30 mA

*Either Input Voltage limit or Input Current limit is sufficient to protect the inputs.

RECOMMENDED OPERATING CONDITIONS

PARAMETER	9396XM/5496XM			9396XC/7496XC			UNITS
	MIN.	TYP.	MAX.	MIN.	TYP.	MAX.	
Supply Voltage V _{CC} (See Note 4)	4.5	5.0	5.5	4.75	5.0	5.25	Volts
Operating Free-Air Temperature Range	-55	25	125	0	25	70	°C
Width of Clock Pulse, t _{p(clock)}	35			35			ns
Width of Preset Pulse, t _{p(preset)}	30			30			ns
Width of Clear Pulse, t _{p(clear)}	30			30			ns
Serial Input Setup Time, t _{setup}	30			30			ns
Serial Input Hold Time, t _{hold}	0			0			ns

X=package type; F for Flatpak, D for Ceramic Dip, P for Plastic Dip. See Packaging Information Section for packages available on this product.

ELECTRICAL CHARACTERISTICS OVER OPERATING TEMPERATURE RANGE (unless otherwise noted)

SYMBOL	PARAMETER	LIMITS			UNITS	TEST CONDITIONS (Note 1)
		MIN.	TYP. (Note 2)	MAX.		
V _{IH}	Input HIGH Voltage	2.0			Volts	Guaranteed V _{IH}
V _{IL}	Input LOW Voltage			0.8	Volts	Guaranteed V _{IL}
V _{OH}	Output HIGH Voltage	2.4	3.5		Volts	V _{CC} = MIN., I _{OH} = -0.4 mA
V _{OL}	Output LOW Voltage		0.22	0.4	Volts	V _{CC} = MIN., I _{OL} = 16 mA
I _{IH}	Input HIGH Current at Any Input Except Parallel Load			40	μA	V _{CC} = MAX., V _{IN} = 2.4 V
	Input HIGH Current at Parallel Load			1.0	mA	V _{CC} = MAX., V _{IN} = 5.5 V
	Input HIGH Current at Parallel Load			200	μA	V _{CC} = MAX., V _{IN} = 2.4 V
I _{IL}	Input LOW Current at Any Input Except Parallel Load			1.0	mA	V _{CC} = MAX., V _{IN} = 5.5 V
	Input LOW Current at Parallel Load			-1.6	mA	V _{CC} = MAX., V _{IN} = 0.4 V
I _{OS}	Output Short Circuit Current (Note 3)	-20		-57	mA	9396/5496 V _{CC} = MAX.
		-18		-57	mA	9396/7496 V _{OUT} = 0 V
I _{CC}	Supply Current		48	68	mA	9396/5496 V _{CC} = MAX.
			48	79	mA	9396/7496 V _{CC} = MAX.

SWITCHING CHARACTERISTICS (T_A = 25°C)

SYMBOL	PARAMETER	LIMITS			UNITS	TEST CONDITIONS
		MIN.	TYP.	MAX.		
f _{max}	Maximum Clock Frequency	10			MHz	V _{CC} = 5.0 V C _L = 15 pF R _L = 400Ω
t _{PLH}	Turn Off Delay Clock to Output		25	40	ns	
t _{PHL}	Turn On Delay Clock to Output		25	40	ns	
t _{PLH}	Turn Off Delay Preset or Parallel Load to Output		28	35	ns	
t _{PHL}	Turn On Delay Clear to Output			55	ns	

NOTES:

- (1) For conditions shown as MIN. or MAX., use the appropriate value specified under recommended operating conditions for the applicable circuit type.
- (2) Typical limits are at V_{CC} = 5.0 V, 25°C.
- (3) Not more than one output should be shorted at a time.
- (4) This voltage value is with respect to network ground terminal.

TTL/MSI 93141/74141

1-OF-10 DECODER/DRIVER (NIXIE)

DESCRIPTION — The 93141/74141 is a BCD-to-Decimal Decoder Driver that is designed to take a 4-bit BCD code input and drive cold-cathode indicator tubes. This decoder utilizes design improvements that minimize switching transients in order to maintain a stable display.

The segments and numeric designations chosen to represent the decimal numbers are shown below. For binary inputs 10 through 15, the outputs are off. These invalid codes can be used in blanking leading or trailing-edge zeros in a display.

The ten high performance, NPN output transistors have a maximum reverse current of 50 μ A at 55V. Typical power dissipation is 55 mW.

PIN NAMES

P_A Address Input
 P_B, P_C, P_D Address Input
 \bar{Q}_0 to \bar{Q}_9 Outputs

LOADING

1 U.L.
 2 U.L.
 *

*See output characteristics.

Max. Current Into Output During "ON" state 7 mA
 Output Leakage at 55 V 50 μ A

1 U.L. = 40 μ A HIGH/1.6 mA LOW.

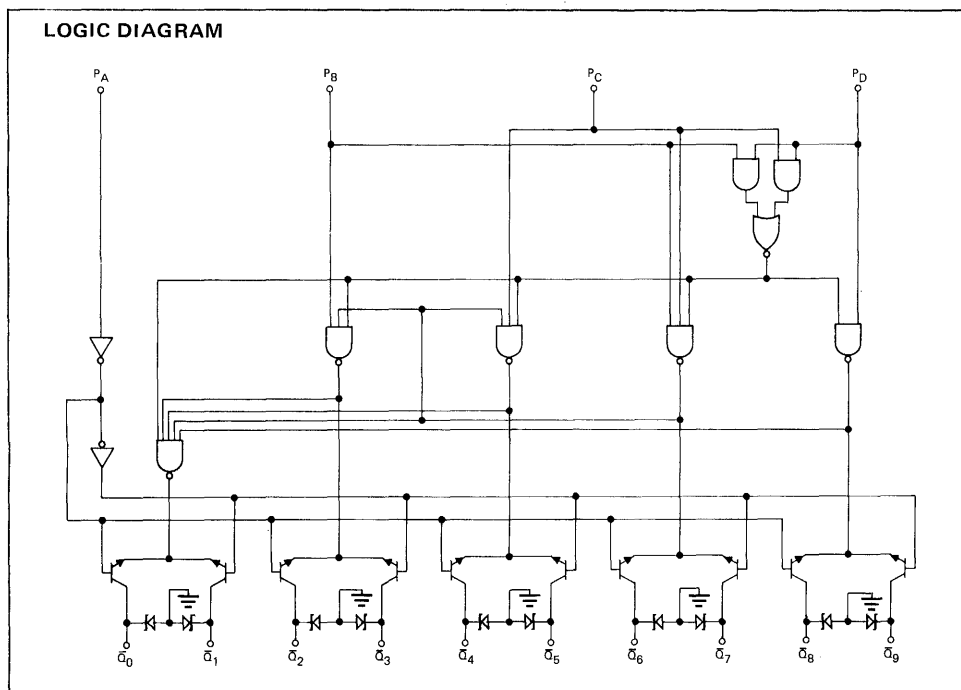
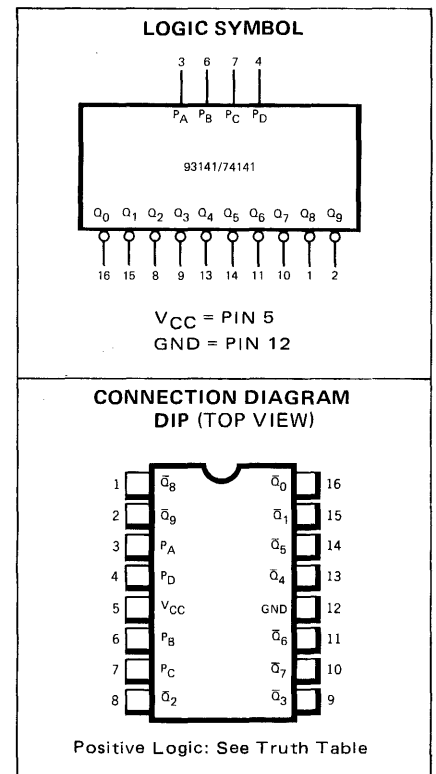

TRUTH TABLE

INPUT				OUTPUT
P_D	P_C	P_B	P_A	ON†
L	L	L	L	0
L	L	L	H	1
L	L	H	L	2
L	L	H	H	3
L	H	L	L	4
L	H	L	H	5
L	H	H	L	6
L	H	H	H	7
H	L	L	L	8
H	L	L	H	9
H	L	H	L	NONE
H	L	H	H	NONE
H	H	L	L	NONE
H	H	L	H	NONE
H	H	H	L	NONE
H	H	H	H	NONE

H = HIGH level,

L = LOW level.

†All other outputs are off

TTL/MSI • 93141/74141

ABSOLUTE MAXIMUM RATINGS (above which the useful life may be impaired)

Storage Temperature	-65°C to +150°C
Temperature (Ambient) Under Bias	0°C to 70°C
V _{CC} Pin Potential to Ground Pin	-0.5 V to +7.0 V
*Input Voltage (dc)	-0.5 V to +5.5 V
*Input Current (dc)	-30 mA to +5.0 mA
Voltage Applied to Outputs (Output HIGH)	-0.5 V to +V _{CC} value
Output Current (dc) (Output LOW)	+30 mA

*Either Input Voltage limit or Input Current limit is sufficient to protect the inputs.

RECOMMENDED OPERATING CONDITIONS

PARAMETER	93141XC/74141XC			UNITS
	MIN.	TYP.	MAX.	
Supply Voltage V _{CC} (See Note 3)	4.75	5.0	5.75	Volts
Operating Free Air Temperature Range	0	25	70	°C
Output Voltage (See Notes 3 & 4)			65	V

X = package type; F for Flatpak, D for Ceramic Dip, P for Plastic Dip. See Packaging Information Section for packages available on this product.

ELECTRICAL CHARACTERISTICS OVER OPERATING TEMPERATURE RANGE (Unless Otherwise Noted)

SYMBOL	PARAMETER	LIMITS			UNITS	TEST CONDITIONS	TEST FIGURE
		MIN.	TYP. (Note 2)	MAX.			
V _{IH}	Input HIGH Voltage	2.0			Volts	Guaranteed Input HIGH Voltage	1 & 2
V _{IL}	Input LOW Voltage			0.8	Volts	Guaranteed Input LOW Voltage	1 & 2
V _{OL}	Output LOW Voltage			2.5	Volts	V _{CC} = MIN., I _{OL} = 7.0 mA	1
V _{OH}	Output HIGH Voltage for input counts 0 thru 9	60			Volts	V _{CC} = MAX., I _{OH} = 0.5 mA	2
I _{OH}	Output HIGH Current			50	μA	V _{CC} = MAX., V _{OUT} = 55 V	2
	Output HIGH Current for input counts 10 thru 15			5.0	μA	V _{CC} = MAX., V _{OUT} = 30 V	2
I _{IH}	Input HIGH Current at P _A			40	μA	V _{CC} = MAX., V _{IN} = 2.4 V	3
				1.0	mA	V _{CC} = MAX., V _{IN} = 5.5 V	
	Input HIGH Current at P _B , P _C , or P _D			80	μA	V _{CC} = MAX., V _{IN} = 2.4 V	3
			1.0	mA	V _{CC} = MAX., V _{IN} = 5.5 V		
I _{IL}	Input LOW Current Into P _A			-1.6	mA	V _{CC} = MAX., V _{IN} = 0.4 V	4
	Input LOW Current Into P _B , P _C , or P _D			-3.2	mA		
I _{CC}	Supply Current		16	25	mA	V _{CC} = MAX.	3

NOTES:

- (1) For conditions shown as MIN. or MAX., use the appropriate value specified under recommended operating conditions for the applicable device type.
- (2) Typical limits are at V_{CC} = 5.0 V, 25°C.
- (3) Voltage values are with respect to network ground terminal.
- (4) This is the maximum voltage which should be applied to any output when it is in the off state.

PARAMETER MEASUREMENT INFORMATION

DC TEST CIRCUITS*

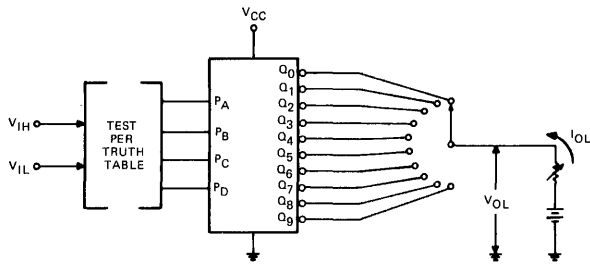

Each output is tested separately.

Fig. 1 V_{IH} , V_{IL} , V_{OL}

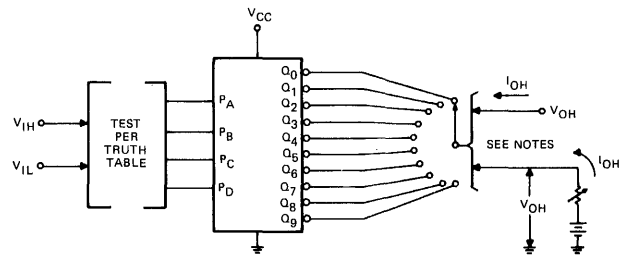

1. Each output is tested separately.
2. V_{OH} is tested at $I_{OH} = 0.5 \text{ mA}$ and I_{OH} is tested at $V_{OH} = 55 \text{ V}$ for all inputs counts. I_{OH} is tested also at $V_{OH} = 30 \text{ V}$ for input counts 10 through 15.

Fig. 2 V_{IH} , V_{IL} , I_{OH} , V_{OH}

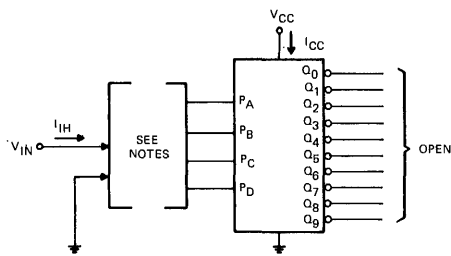

1. When testing I_{IH} , each input is tested separately with all other inputs grounded.
2. When testing I_{CC} , all inputs are grounded.

Fig. 3 I_{IH} , I_{CC}

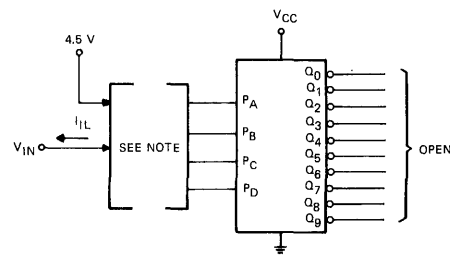

Each input is tested separately, with all other inputs at 4.5 V.

Fig. 4 I_{IL}

*Arrows indicate actual direction of current flow. Current into a terminal is a positive value.

APPLICATIONS

GENERAL – When these decoder/drivers are used in close proximity (on the same circuit board) with standard digital integrated circuits, care should be exercised to ensure that the impedance of the ground bus (including interconnections) is sufficiently low to absorb the normal energy levels resulting from switching the tube elements.

DRIVING INDICATOR TUBES – As shown in Figure 5, the 93141/74141 requires no external components for driving cold-cathode indicator tubes. The versatility here is limited only by the system capability to control the data inputs.

A suggested method for blanking extraneous zeros is shown in Figure 6. Any input count above decimal 9 may be used for blanking. In the following application decimal 12 is used. When the most significant bit (MSB) or the least significant bit (LSB) is decimal 0(0000), that indicator is blanked while decimal 12 (binary 1100) is applied to the 93141/74141 inputs causing all the outputs to be off. If the MSB or LSB is decimal 0 and being blanked, this signal is gated with and blanks the next smaller digit. This scheme is easily expandable to n digits.

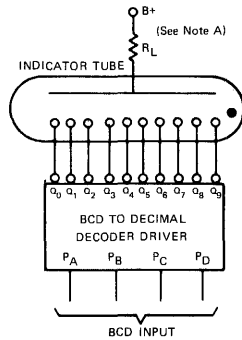
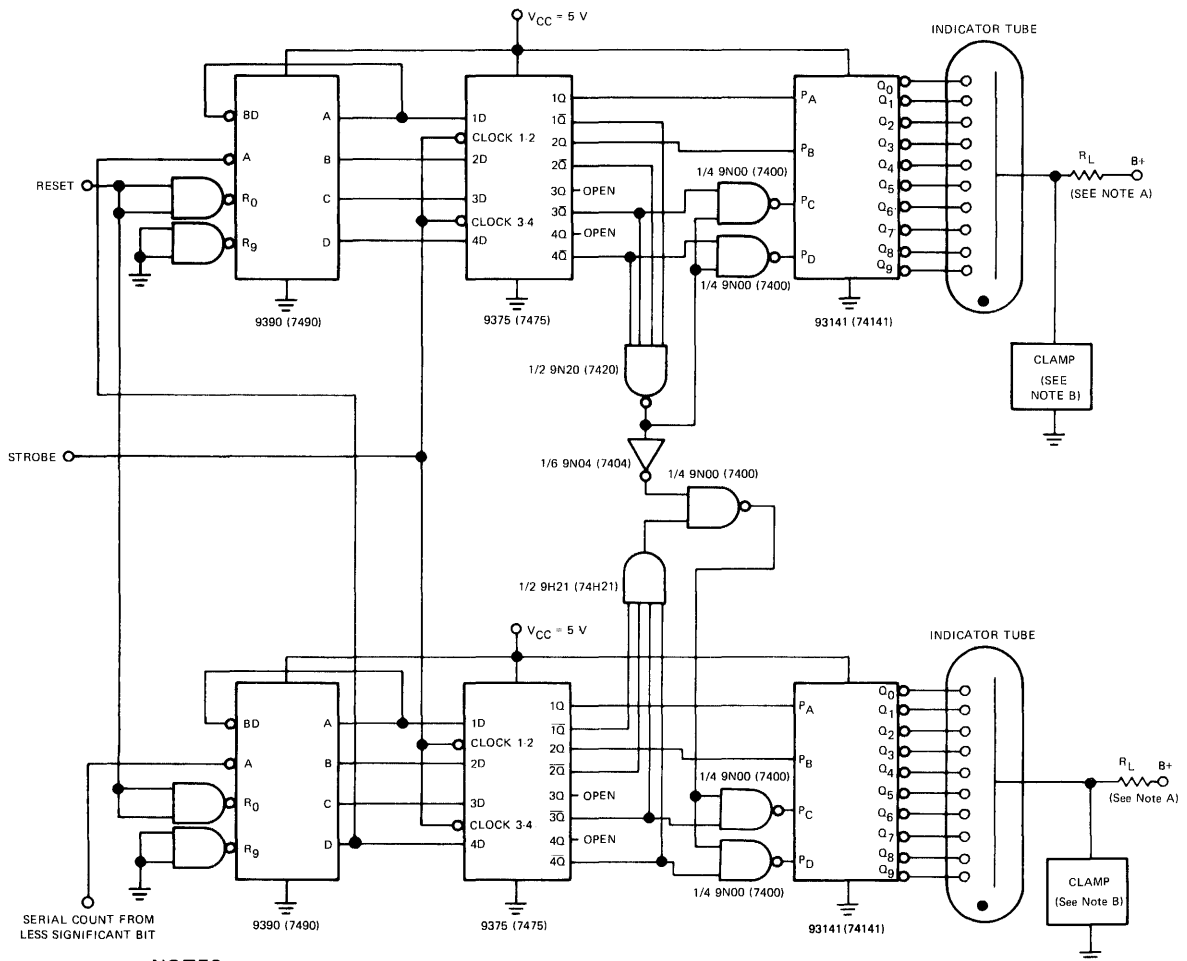

Fig. 5



NOTES:

- A. Values for B+ and R_L are as specified by the tube manufacturer.
- B. Blanking is assured only if the anode of the indicator tube is clamped at 150 volts maximum.

Fig. 6

TTL/MSI 93150/54150, 74150 93151/54151, 74151 • 93152/54152, 74152

16-INPUT AND 8-INPUT MULTIPLEXER

DESCRIPTION – The 93150/54150, 74150 is a 16-Input Multiplexer which features active LOW strobe and internal select decoding. A HIGH at the strobe input forces the output HIGH regardless of input conditions.

The 93151/54151, 74151 is an 8-Input Multiplexer with active LOW strobe, internal select decoding and complementary outputs.

The 93152/54152, 74152 is an 8-Input Multiplexer with internal select decoding and a single inverted output.

In each of the multiplexers data is routed from a particular input to the output according to the binary code applied to the select inputs.

Typical power dissipations are: 93150/54150, 74150 – 200 mW; 93151/54151, 74151 – 145 mW; 93152/54152, 74152 – 130 mW.

PIN NAMES

E_0 to E_{15}	Data Inputs
D_0 to D_7	Data inputs
\bar{S}	Strobe (Enable) Input
A, B, C, D	Data Select Inputs
\bar{W}	Data Output
Y	Data Output

LOADING

1 U.L.
1 U.L.
1 U.L.
1 U.L.
10 U.L.
10 U.L.

NOTE: 1 U.L. = 40 μ A HIGH/1.6 mA LOW.

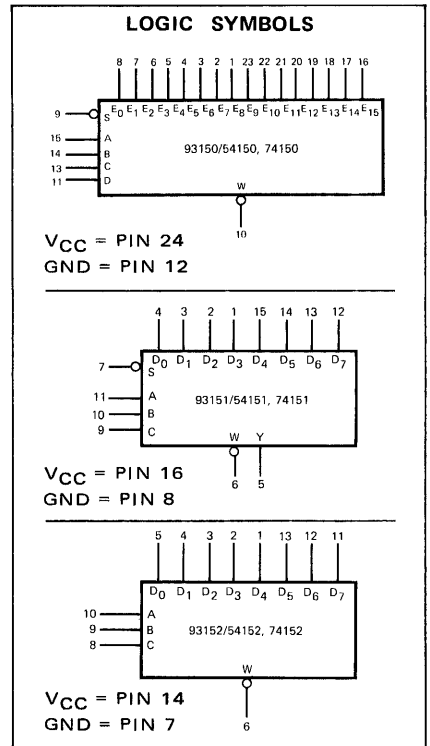

CONNECTION DIAGRAMS
DIP (TOP VIEWS)*

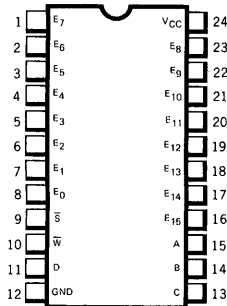

93150/54150, 74150

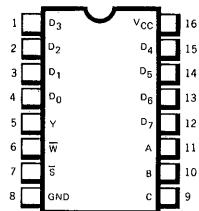

93151/54151, 74151

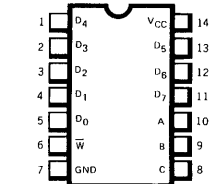

93152/54152, 74152

*Pin assignments for these circuits are the same for all packages.

LOGIC DIAGRAMS
93150/54150, 74150

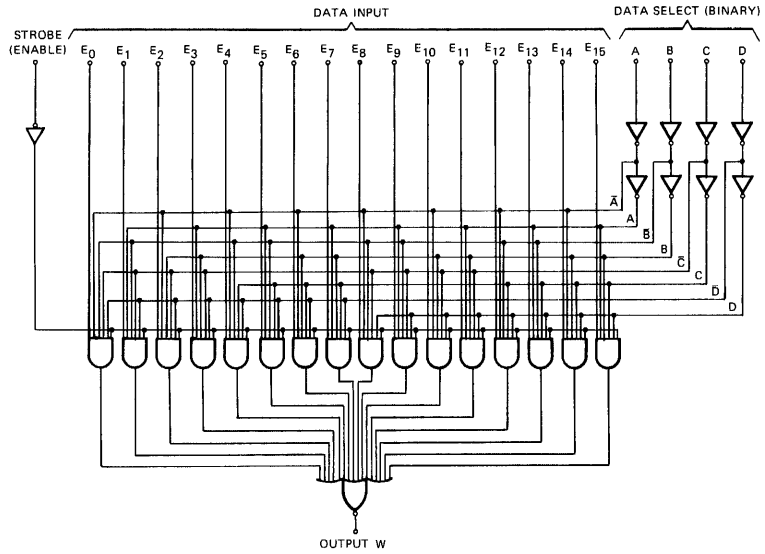

Positive Logic

$$W = S(\bar{A}\bar{B}\bar{C}\bar{D}E_0 + \bar{A}\bar{B}\bar{C}\bar{D}E_1 + \bar{A}\bar{B}\bar{C}\bar{D}E_2 + \bar{A}\bar{B}\bar{C}\bar{D}E_3 + \bar{A}\bar{B}\bar{C}\bar{D}E_4 + \bar{A}\bar{B}\bar{C}\bar{D}E_5 + \bar{A}\bar{B}\bar{C}\bar{D}E_6 + \bar{A}\bar{B}\bar{C}\bar{D}E_7 + \bar{A}\bar{B}\bar{C}\bar{D}E_8 + \bar{A}\bar{B}\bar{C}\bar{D}E_9 + \bar{A}\bar{B}\bar{C}\bar{D}E_{10} + \bar{A}\bar{B}\bar{C}\bar{D}E_{11} + \bar{A}\bar{B}\bar{C}\bar{D}E_{12} + \bar{A}\bar{B}\bar{C}\bar{D}E_{13} + \bar{A}\bar{B}\bar{C}\bar{D}E_{14} + \bar{A}\bar{B}\bar{C}\bar{D}E_{15})$$

93151/54151, 74151

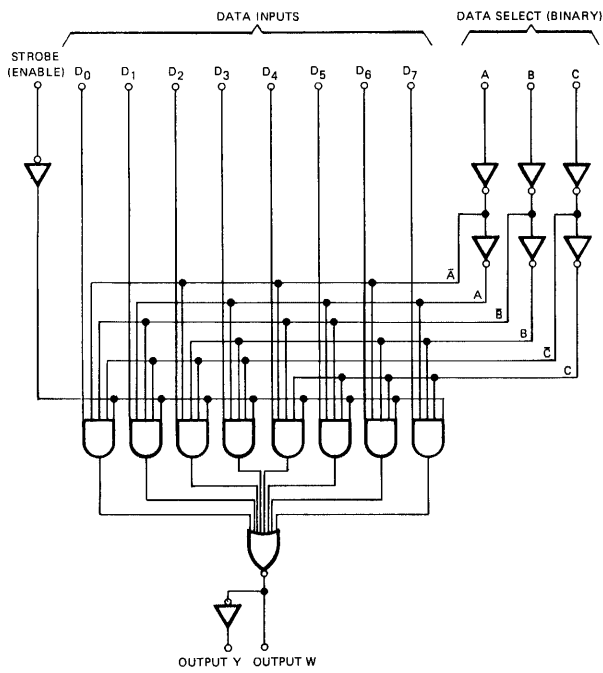

Positive Logic

$$Y = \bar{S}(\bar{A}\bar{B}\bar{C}D_0 + \bar{A}\bar{B}\bar{C}D_1 + \bar{A}\bar{B}\bar{C}D_2 + \bar{A}\bar{B}\bar{C}D_3 + \bar{A}\bar{B}\bar{C}D_4 + \bar{A}\bar{B}\bar{C}D_5 + \bar{A}\bar{B}\bar{C}D_6 + \bar{A}\bar{B}\bar{C}D_7) \quad W = \bar{Y}$$

93152/54152, 74152

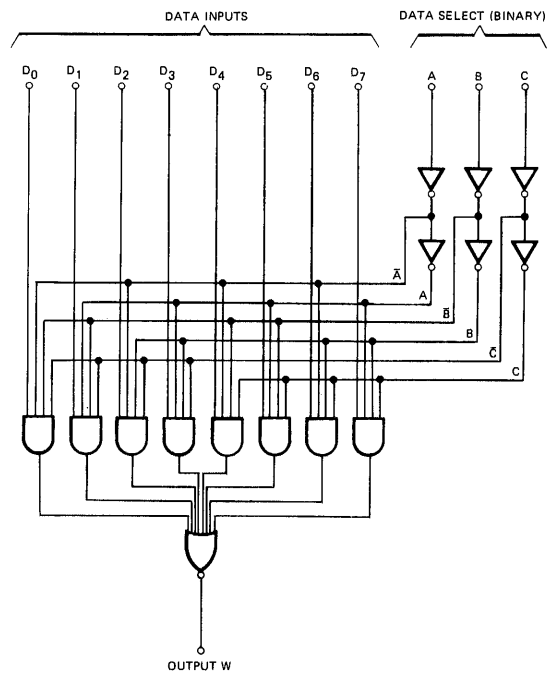

Positive Logic

$$W = (\bar{A}\bar{B}\bar{C}D_0 + \bar{A}\bar{B}\bar{C}D_1 + \bar{A}\bar{B}\bar{C}D_3 + \bar{A}\bar{B}\bar{C}D_4 + \bar{A}\bar{B}\bar{C}D_5 + \bar{A}\bar{B}\bar{C}D_6 + \bar{A}\bar{B}\bar{C}D_7)$$

TRUTH TABLES

93150/54150, 74150

				INPUTS															OUTPUT			
D	C	B	A	STROBE	E ₀	E ₁	E ₂	E ₃	E ₄	E ₅	E ₆	E ₇	E ₈	E ₉	E ₁₀	E ₁₁	E ₁₂	E ₁₃	E ₁₄	E ₁₅	W	
X	X	X	X	H	X	X	X	X	X	X	X	X	X	X	X	X	X	X	X	X	X	H
L	L	L	L	L	L	X	X	X	X	X	X	X	X	X	X	X	X	X	X	X	X	H
L	L	L	L	L	L	H	X	X	X	X	X	X	X	X	X	X	X	X	X	X	X	L
L	L	L	H	L	L	X	L	X	X	X	X	X	X	X	X	X	X	X	X	X	X	H
L	L	L	H	L	L	X	X	H	X	X	X	X	X	X	X	X	X	X	X	X	X	L
L	L	H	L	L	L	X	X	L	X	X	X	X	X	X	X	X	X	X	X	X	X	H
L	L	H	L	L	L	X	X	X	H	X	X	X	X	X	X	X	X	X	X	X	X	L
L	H	L	L	L	L	X	X	X	X	L	X	X	X	X	X	X	X	X	X	X	X	H
L	H	L	L	L	L	X	X	X	X	H	X	X	X	X	X	X	X	X	X	X	X	L
L	H	L	H	L	L	X	X	X	X	L	X	X	X	X	X	X	X	X	X	X	X	H
L	H	L	H	L	L	X	X	X	X	X	H	X	X	X	X	X	X	X	X	X	X	L
L	H	H	L	L	L	X	X	X	X	X	L	X	X	X	X	X	X	X	X	X	X	H
L	H	H	L	L	L	X	X	X	X	X	H	X	X	X	X	X	X	X	X	X	X	L
L	H	H	H	L	L	X	X	X	X	X	X	L	X	X	X	X	X	X	X	X	X	H
L	H	H	H	L	L	X	X	X	X	X	X	X	H	X	X	X	X	X	X	X	X	L
H	L	L	L	L	L	X	X	X	X	X	X	X	X	X	X	X	X	X	X	X	X	H
H	L	L	L	L	L	X	X	X	X	X	X	X	X	X	X	X	X	X	X	X	X	L
H	L	L	H	L	L	X	X	X	X	X	X	X	X	X	X	X	X	X	X	X	X	H
H	L	L	H	L	L	X	X	X	X	X	X	X	X	X	X	X	X	X	X	X	X	L
H	L	H	L	L	L	X	X	X	X	X	X	X	X	X	X	X	X	X	X	X	X	H
H	L	H	L	L	L	X	X	X	X	X	X	X	X	X	X	X	X	X	X	X	X	L
H	L	H	H	L	L	X	X	X	X	X	X	X	X	X	X	X	X	X	X	X	X	H
H	L	H	H	L	L	X	X	X	X	X	X	X	X	X	X	X	X	X	X	X	X	L
H	H	L	L	L	L	X	X	X	X	X	X	X	X	X	X	X	X	X	X	X	X	H
H	H	L	L	L	L	X	X	X	X	X	X	X	X	X	X	X	X	X	X	X	X	L
H	H	L	H	L	L	X	X	X	X	X	X	X	X	X	X	X	X	X	X	X	X	H
H	H	L	H	L	L	X	X	X	X	X	X	X	X	X	X	X	X	X	X	X	X	L
H	H	H	L	L	L	X	X	X	X	X	X	X	X	X	X	X	X	X	X	X	X	H
H	H	H	L	L	L	X	X	X	X	X	X	X	X	X	X	X	X	X	X	X	X	L
H	H	H	H	L	L	X	X	X	X	X	X	X	X	X	X	X	X	X	X	X	X	H
H	H	H	H	L	L	X	X	X	X	X	X	X	X	X	X	X	X	X	X	X	X	L

When used to indicate an input condition, X = LOGICAL H or LOGICAL L.

93151/54151, 74151 AND 93152/54152, 74152

				INPUTS								OUTPUTS	
C	B	A	STROBE(1)	D ₀	D ₁	D ₂	D ₃	D ₄	D ₅	D ₆	D ₇	Y(1)	W
X	X	X	H	X	X	X	X	X	X	X	X	L	H
L	L	L	L	L	X	X	X	X	X	X	X	L	H
L	L	L	L	L	H	X	X	X	X	X	X	H	L
L	L	H	L	L	X	L	X	X	X	X	X	L	H
L	L	H	L	L	X	H	X	X	X	X	X	H	L
L	H	L	L	L	X	X	L	X	X	X	X	L	H
L	H	L	L	L	X	X	H	X	X	X	X	H	L
L	H	H	L	L	X	X	X	L	X	X	X	L	H
L	H	H	L	L	X	X	X	H	X	X	X	H	L
H	L	L	L	L	X	X	X	X	L	X	X	L	H
H	L	L	L	L	X	X	X	X	H	X	X	H	L
H	L	H	L	L	X	X	X	X	X	L	X	L	H
H	L	H	L	L	X	X	X	X	X	H	X	H	L
H	H	L	L	L	X	X	X	X	X	X	L	L	H
H	H	L	L	L	X	X	X	X	X	X	H	L	H
H	H	H	L	L	X	X	X	X	X	X	L	L	H
H	H	H	L	L	X	X	X	X	X	X	H	H	L

NOTES:
 1. 54151, 74151 only.
 2. When used to indicate an input, X = irrelevant.

ABSOLUTE MAXIMUM RATINGS (above which the useful life may be impaired)

Storage Temperature	-65°C to +150°C
Temperature (Ambient) Under Bias	-55°C to +125°C
V _{CC} Pin Potential to Ground Pin	-0.5 V to +7.0 V
*Input Voltage (dc)	-0.5 V to +5.5 V
*Input Current (dc)	-30 mA to +5.0 mA
Voltage Applied to Outputs (Output HIGH)	-0.5 V to +V _{CC} value
Output Current (dc) (Output LOW)	+30 mA

*Either Input Voltage limit or Input Current limit is sufficient to protect the inputs.

RECOMMENDED OPERATING CONDITIONS

PARAMETER	93150XM/54150XM 93151XM/54151XM 93152XM/54152XM			93150XC/74150XC 93151XC/74151XC 93152XC/74152XC			UNITS
	MIN.	TYP.	MAX.	MIN.	TYP.	MAX.	
Supply Voltage V_{CC}	4.5	5.0	5.5	4.75	5.0	5.25	Volts
Operating Free Air Temperature Range	-55	25	125	0	25	70	°C
Normalized Fan Out from Each Output, N	LOW Level		10			10	U.L.
	HIGH Level		20			20	

X = package type; F for Flatpak, D for Ceramic Dip, P for Plastic Dip. See Packaging Information Section for packages available on this product.

ELECTRICAL CHARACTERISTICS OVER OPERATING TEMPERATURE RANGE (Unless Otherwise Noted)

SYMBOL	PARAMETER	LIMITS			UNITS	TEST CONDITIONS (Note 1)	TEST FIGURE
		MIN.	TYP. (Note 2)	MAX.			
V_{IH}	Input HIGH Voltage	2.0			Volts	Guaranteed Input HIGH Threshold Voltage	1
V_{IL}	Input LOW Voltage			0.8	Volts	Guaranteed Input LOW Threshold Voltage	2
V_{OH}	Output HIGH Voltage	2.4			Volts	$V_{CC} = \text{MIN.}, I_{OH} = -800 \mu\text{A}, V_{IH} = 2.0 \text{ V}, V_{IL} = 0.8 \text{ V}$	1 & 2
V_{OL}	Output LOW Voltage			0.4	Volts	$V_{CC} = \text{MIN.}, I_{OL} = 16 \text{ mA}, V_{IH} = 2.0 \text{ V}, V_{IL} = 0.8 \text{ V}$	1 & 2
I_{IH}	Input HIGH Current (Each Input)			40	μA	$V_{CC} = \text{MAX.}, V_{IN} = 2.4 \text{ V}$	3
				1.0	mA	$V_{CC} = \text{MAX.}, V_{IN} = 5.5 \text{ V}$	
I_{IL}	Input LOW Current (Each Input)			-1.6	mA	$V_{CC} = \text{MAX.}, V_{IN} = 0.4 \text{ V}$	3
I_{OS}	Output Short Circuit Current (Note 3)	-20		-55	mA	93150/54150, 93151/54151, 93152/54152, $V_{CC} = \text{MAX.}, V_{out} = 0\text{V}$	4
		-18		-55	mA	93150/74150, 93151/74151, 93152/74152, $V_{CC} = \text{MAX.}, V_{out} = 0\text{V}$	
I_{CC}	Supply Current		40	68	mA	93150/54150, 74150	5
			29	48	mA	93151/54151, 74151	
			26	43	mA	93152/54152, 74152	

SWITCHING CHARACTERISTICS ($T_A = 25^\circ\text{C}$)

SYM-BOL	PARAMETER	LIMITS			UNITS	TEST CONDITIONS	TEST FIGURE
		MIN.	TYP.	MAX.			
t_{PHL} t_{PLH}	A, B, or C Input to Y Output, 4 Levels		20 35	30 52	ns ns	$V_{CC} = 5.0 \text{ V}$ $C_L = 15 \text{ pF}$ $R_L = 400 \Omega$	A
t_{PHL} t_{PLH}	A, B, C, or D Input to W Output, 3 Levels		22 22	33 35	ns ns		
t_{PHL} t_{PLH}	Strobe Input to Y Output		19 35	30 52	ns ns		
t_{PHL} t_{PLH}	Strobe Input to W Output		21 15.5	30 24	ns ns		
t_{PHL} t_{PLH}	D_0 thru D_7 Input to Y Output		16 19	24 29	ns ns		
t_{PHL} t_{PLH}	E_0 thru E_{15}, D_0 thru D_7 Input to W Output		8.5 13	14 20	ns ns		

NOTES:

- (1) For conditions shown as MIN. or MAX., use the appropriate value specified under recommended operating conditions for the applicable device type.
- (2) Typical limits are at $V_{CC} = 5.0 \text{ V}, 25^\circ\text{C}$.
- (3) Not more than one output of the 93151/54151, 74151 should be shorted at a time.

PARAMETER MEASUREMENT INFORMATION

DC TEST CIRCUITS*

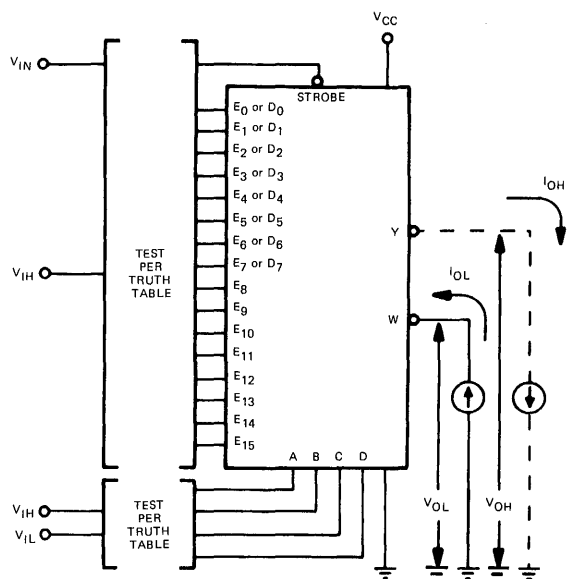

1. V_{IL} is applied to STROBE; 8-4-2-1 code is applied to A, B, C, D; and input/output condition is tested for each step of the code.
2. V_{IH} is applied to STROBE at which time V_{OL} is measured at Y and V_{OH} is measured at W.

Fig. 1

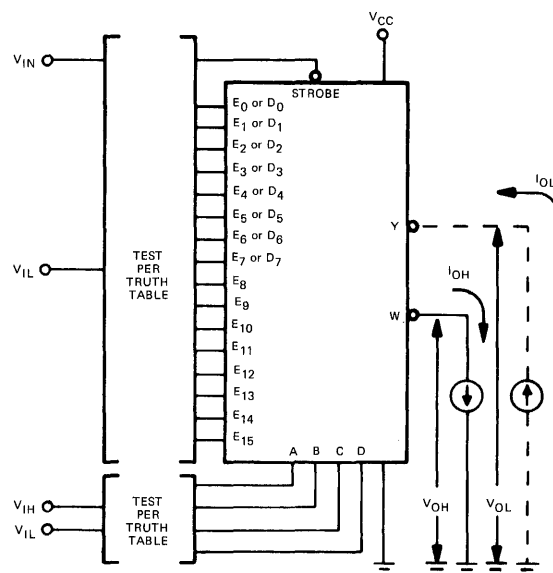

1. V_{IL} is applied to STROBE; 8-4-2-1 is applied to A, B, C, D; and input/output condition is tested for each step of the code.

Fig. 2

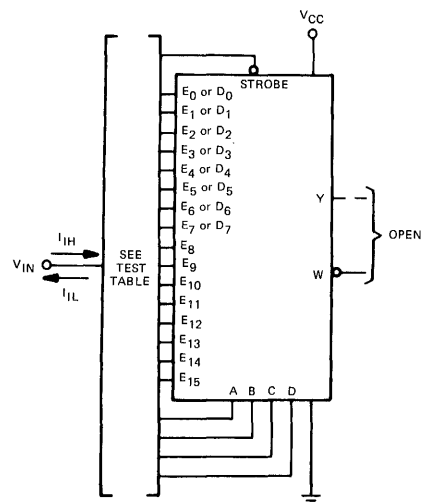

1. When testing strobe input, all other inputs are open.

Fig. 3

INPUT CONDITIONS				TEST	
A	B	C	D	I_{IL}	I_{IH}
L	L	L	L	E ₀ or D ₀	E ₁₅ or D ₇
H	L	L	L	E ₁ or D ₁	E ₁₄ or D ₆
L	H	L	L	E ₂ or D ₂	E ₁₃ or D ₅
H	H	L	L	E ₃ or D ₃	E ₁₂ or D ₄
L	L	H	L	E ₄ or D ₄	E ₁₁ or D ₃
H	L	H	L	E ₅ or D ₅	E ₁₀ or D ₂
L	H	H	L	E ₆ or D ₆	E ₉ or D ₁
H	H	H	L	E ₇ or D ₇	E ₈ or D ₀
L	L	L	H	E ₈	E ₇
H	L	L	H	E ₉	E ₆
L	H	L	H	E ₁₀	E ₅
H	H	L	H	E ₁₁	E ₄

INPUT CONDITIONS				TEST	
A	B	C	D	I_{IL}	I_{IH}
L	L	H	H	E ₁₂	E ₃
H	L	H	H	E ₁₃	E ₂
L	H	H	H	E ₁₄	E ₁
H	H	H	H	E ₁₅	E ₀
L				A	
	L			B	
		L		C	
			L	D	
H					A
	H				B
		H			C
			H		D

*Arrows indicate actual direction of current flow. Tests as shown, are for the 93150/54150, 74150. Identical tests as applicable are performed for the 93151/54151, 74151 and 93152/54152, 74152.

PARAMETER MEASUREMENT INFORMATION

DC TEST CIRCUITS* (Continued)

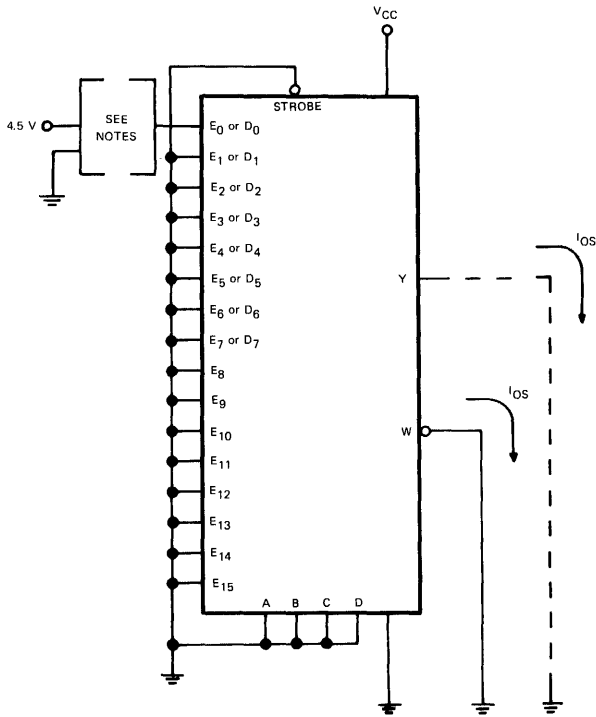

1. When testing W output, apply GND to D₀ and E₀ input.
2. When testing Y output of 93151/54151, 74151 apply 4.5 V to D₀ and measure I_{OS}.

Fig. 4

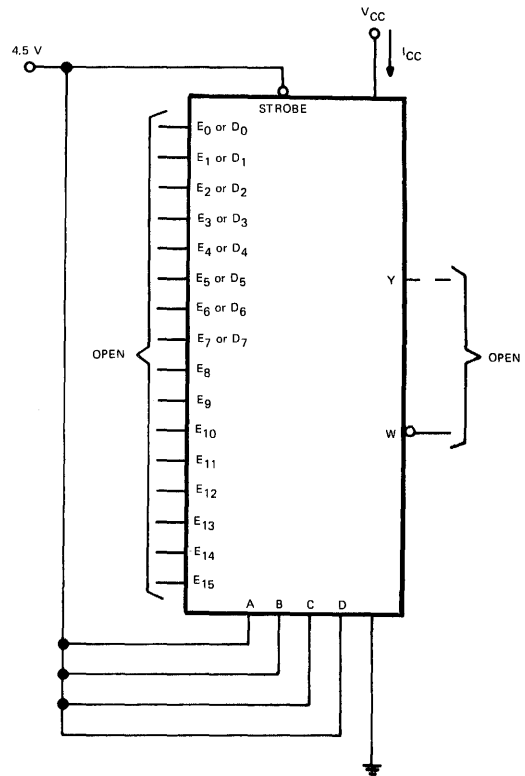
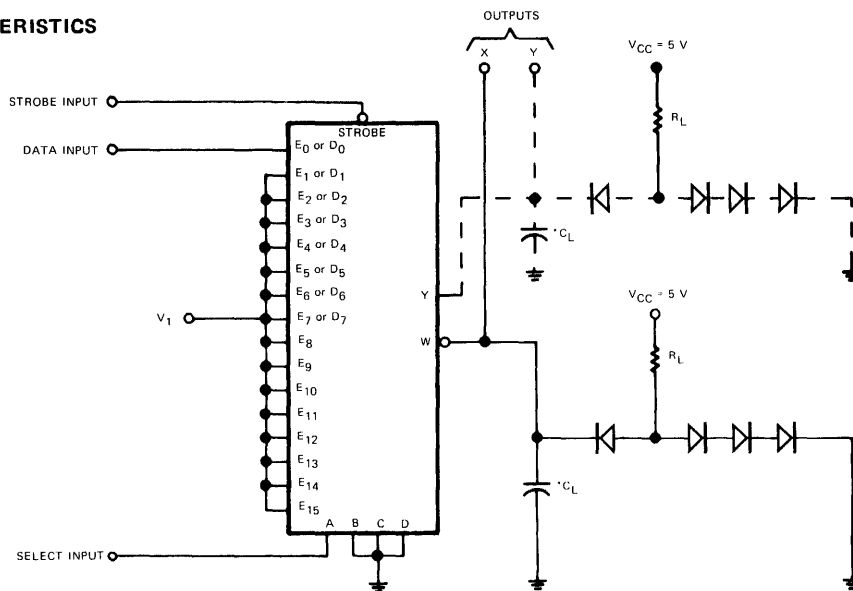

Fig. 5

*Arrows indicate actual direction of current flow. Tests as shown, are for the 93150/54150, 74150. Identical tests as applicable are performed for the 93151/54151, 74151 and 93152/54152, 74152.

SWITCHING CHARACTERISTICS



*C_L Includes probe and jig capacitance.

Fig. A SWITCHING TIMES

PARAMETER MEASUREMENT INFORMATION

SWITCHING CHARACTERISTICS (cont'd)

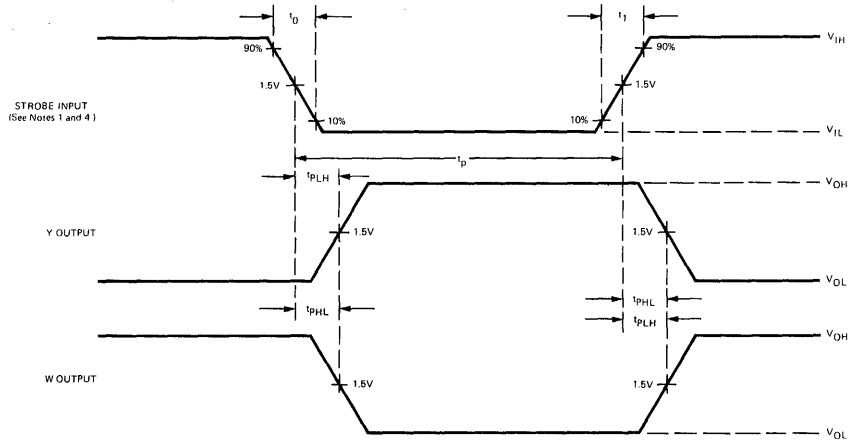

STROBE-TO-OUTPUT VOLTAGE WAVEFORMS

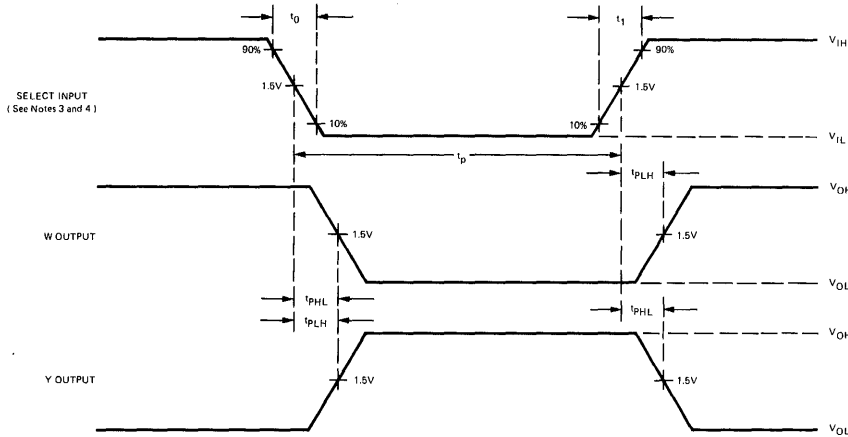

SELECT INPUT-TO-OUTPUT VOLTAGE WAVEFORMS

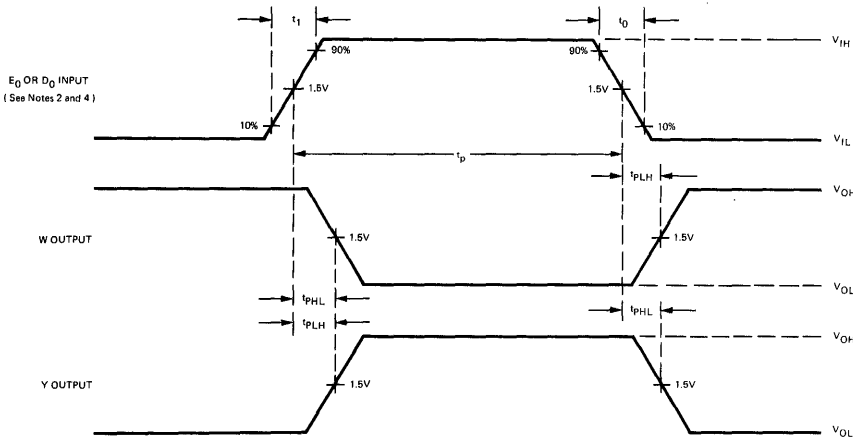

DATA INPUT-TO-OUTPUT VOLTAGE WAVEFORMS

NOTES:

1. When measuring strobe to output times select input is at a LOW level, E_0 or D_0 is at a HIGH level, $V_1 = 4.5$ V.
2. When measuring $dtat$ input-to-output times strobe and select inputs are at a LOW level and $V_1 = 4.5$ V.
3. When measuring select input-to-output times strobe input is at a LOW level, data input is at a HIGH level and $V_1 = 0$.
4. The input pulse has the following V_{IL} characteristics: $V_{IH} = 3$ V, $V_{IL} = 0$ V; $t_1 = t_0 = 10$ ns, PRR = 1 MHz, duty cycle = 50%, and generator $Z_{out} \approx 50\Omega$.

Fig. A SWITCHING TIMES

†Tests, as shown, are for the 93150/54150, 74150. Identical tests as applicable are performed for the 93151/54151, 74151 and 93152/54152, 74152.

TTL/MSI 93153/54153, 74153

DUAL 4-INPUT DATA SELECTOR/MULTIPLEXER

DESCRIPTION — The 93153/94153, 74153 is a monolithic, high speed, Dual 4-Input Digital Multiplexer. It consists of two multiplexing circuits with separate strobe inputs for each of the two 4-line sections, and with common input select logic. Active pull up outputs ensure high drive and high speed performance with a full fan out of 10 unit loads in the LOW state. Typical power dissipation is 180 mW.

PIN NAMES

1G, 2G, 1C₀₋₃, 2C₀₋₃, A, B
1Y, 2Y

1 Unit Load (U.L.) = 40 μA HIGH/1.6 mA LOW

Inputs
Outputs

LOADING

1 U.L.
10 U.L.

TRUTH TABLE

ADDRESS INPUTS		DATA INPUTS				STROBE	OUTPUT
B	A	C ₀	C ₁	C ₂	C ₃	G	Y
X	X	X	X	X	X	H	L
L	L	L	X	X	X	L	L
L	L	H	X	X	X	L	H
L	H	X	L	X	X	L	L
L	H	X	H	X	X	L	H
H	L	X	X	L	X	L	L
H	L	X	X	H	X	L	H
H	H	X	X	X	L	L	L
H	H	X	X	X	H	L	H

Address Inputs A and B are common to both sections
H = HIGH level, L = LOW level, X = irrelevant

LOGIC DIAGRAM

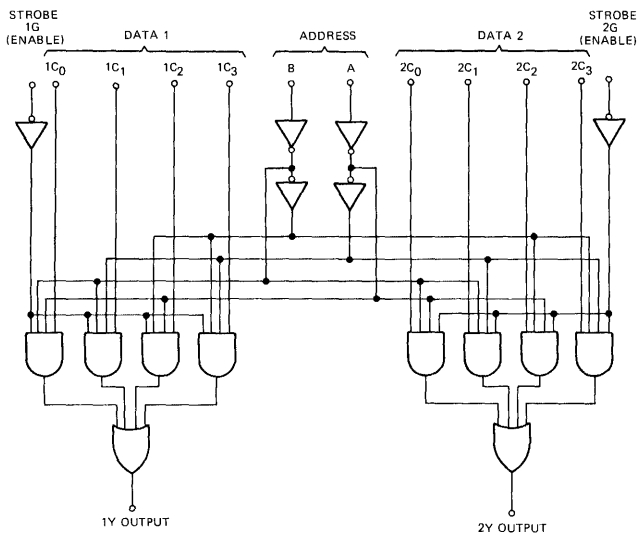

LOGIC SYMBOL

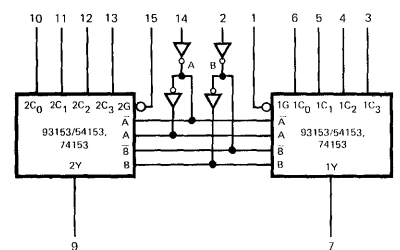

V_{CC} = PIN 16
GND = PIN 8

**CONNECTION DIAGRAM
DIP (TOP VIEW)**

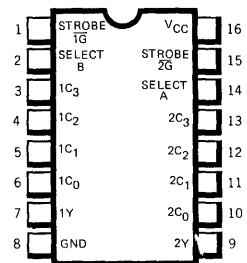

FLATPAK (TOP VIEW)

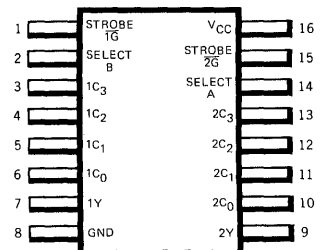

Positive Logic: See Truth Table.

TTL/MSI • 93153/54153, 74153

ABSOLUTE MAXIMUM RATINGS (above which the useful life may be impaired)

Storage Temperature	-65°C to +150°C
Temperature (Ambient) Under Bias	-55°C to +125°C
V _{CC} Pin Potential to Ground Pin	-0.5 V to +7.0 V
*Input Voltage (dc)	-0.5 V to +5.5 V
*Input Current (dc)	-30 mA to +5.0 mA
Voltage Applied to Outputs (Output HIGH)	-0.5 V to +V _{CC} value
Output Current (dc) (Output LOW)	+30 mA

*Either Input Voltage limit or Input Current limit is sufficient to protect the inputs.

RECOMMENDED OPERATING CONDITIONS

PARAMETER	93153XM/54153XM			93153XC/74153XC			UNITS
	MIN.	TYP.	MAX.	MIN.	TYP.	MAX.	
Supply Voltage V _{CC}	4.5	5.0	5.5	4.75	5.0	5.25	Volts
Operating Free-Air Temperature Range	-55	25	125	0	25	70	°C
Normalized Fan Out from Each Output, N	HIGH Level		20			20	U.L.
	LOW Level		10			10	

X = package type; F for Flatpak, D for Ceramic Dip, P for Plastic Dip. See Packaging Information Section for packages available on this product.

ELECTRICAL CHARACTERISTICS OVER OPERATING TEMPERATURE RANGE (Unless Otherwise Noted)

SYMBOL	PARAMETER	LIMITS			UNITS	TEST CONDITIONS (Note 1)	TEST FIGURE	
		MIN.	TYP. (Note 2)	MAX.				
V _{IH}	Input HIGH Voltage	2.0			Volts	Guaranteed Input HIGH Threshold Voltage	1 & 2	
V _{IL}	Input LOW Voltage			0.8	Volts	Guaranteed Input LOW Threshold Voltage	1 & 2	
V _{OH}	Output HIGH Voltage	2.4	3.1		Volts	V _{CC} = MIN., I _{OH} = -800 μA, V _{IH} = 2.0 V, V _{IL} = 0.8 V	1	
V _{OL}	Output LOW Voltage		0.2	0.4	Volts	V _{CC} = MIN., I _{OL} = 16 mA, V _{IH} = 2.0 V, V _{IL} = 0.8 V	2	
I _{IH}	Input HIGH Current			40	μA	V _{CC} = MAX., V _{IN} = 2.4 V	3	
				1.0	mA	V _{CC} = MAX., V _{IN} = 5.5 V		
I _{IL}	Input LOW Current			-1.6	mA	V _{CC} = MAX., V _{IN} = 0.4 (each input)	3	
I _{OS}	Output Short Circuit Current (Note 3)	-20		-55	mA	93153/54153	V _{CC} = MAX.	4
		-18		-57	mA	93153/74153		
I _{CCL}	Supply Current LOW		36	52	mA	93153/54153	V _{CC} = MAX.	5
			36	60	mA	93153/74153		

SWITCHING CHARACTERISTICS (T_A = 25°C)

SYMBOL	PARAMETER	LIMITS			UNITS	TEST CONDITIONS	TEST FIGURE
		MIN.	TYP.	MAX.			
t _{PLH}	Data Input to Y Output		12	18	ns	V _{CC} = 5.0 V C _L = 30 pF R _L = 400 Ω	A
t _{PHL}			15	23			
t _{PLH}	Address Input to Y Output		22	34	ns		
t _{PHL}			22	34			
t _{PLH}	Strobe Input to Y Output		19	30	ns		
t _{PHL}			15	23			

NOTES:

- (1) For conditions shown as MIN. or MAX., use the appropriate value specified under recommended operating conditions for the applicable device type.
- (2) Typical limits are at V_{CC} = 5.0 V, 25°C.
- (3) Not more than one output should be shorted at a time.



PARAMETER MEASUREMENT INFORMATION

DC TEST CIRCUITS*

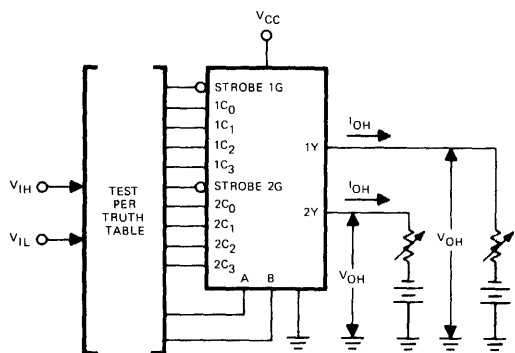

Fig. 1 V_{IH} , V_{IL} , V_{OH}

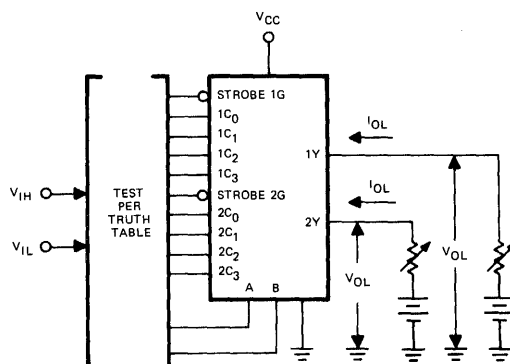
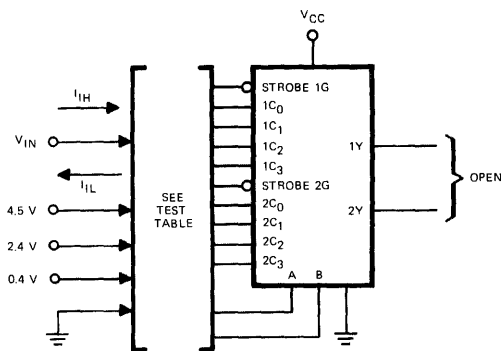

Fig. 2 V_{IH} , V_{IL} , V_{OL}

TEST TABLE

INPUT CONDITIONS				APPLY V_{IN}	
B	A	1G	2G	TEST I_{IL}	TEST I_{IH}
L	L	H	H		1C ₃ , 2C ₃
L	H	H	H		1C ₂ , 2C ₂
H	L	H	H		1C ₁ , 2C ₁
H	H	H	H		A, B, 1G, 2G, 1C ₀ , 2C ₀
L	L	L	L	A, B, 1G, 2G, 1C ₀ , 2C ₀	
L	H	L	L	1C ₁ , 2C ₁	
H	L	L	L	1C ₂ , 2C ₂	
H	H	L	L	1C ₃ , 2C ₃	

H = 2.4 V, L = 0.4 V



Note: Each input is tested separately. When I_{iH} is tested, all C inputs not under test are grounded. When I_{iL} is tested, all C inputs not under test are at 4.5 V.

Fig. 3 I_{iH} , I_{iL}

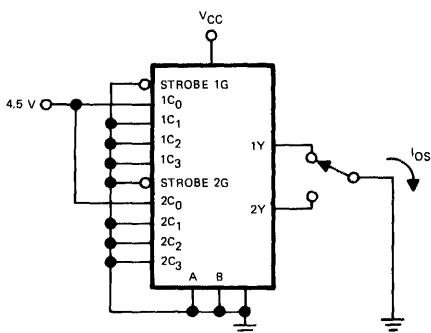

Note: Each output is tested separately.

Fig. 4 I_{OS}

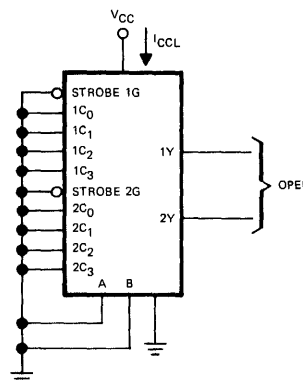
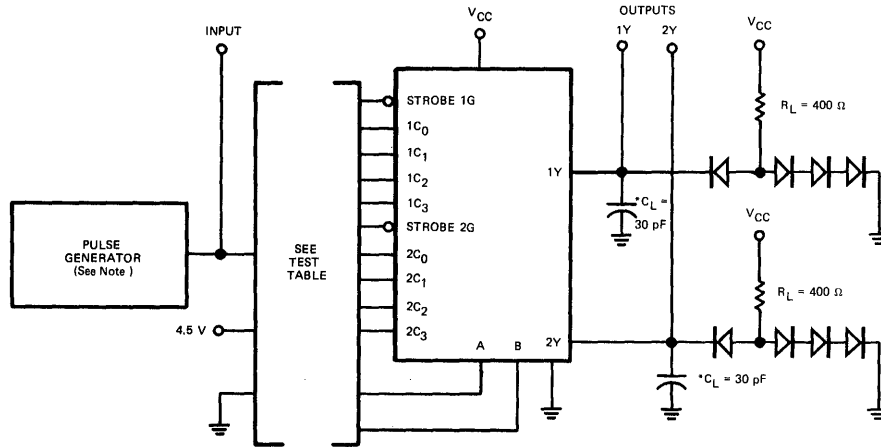

Fig. 5 I_{CCL}

*Arrows indicate actual direction of current flow. Current into a terminal is a positive value.

PARAMETER MEASUREMENT INFORMATION

SWITCHING CHARACTERISTICS



*Includes probe and jig capacitance.

TEST CIRCUIT

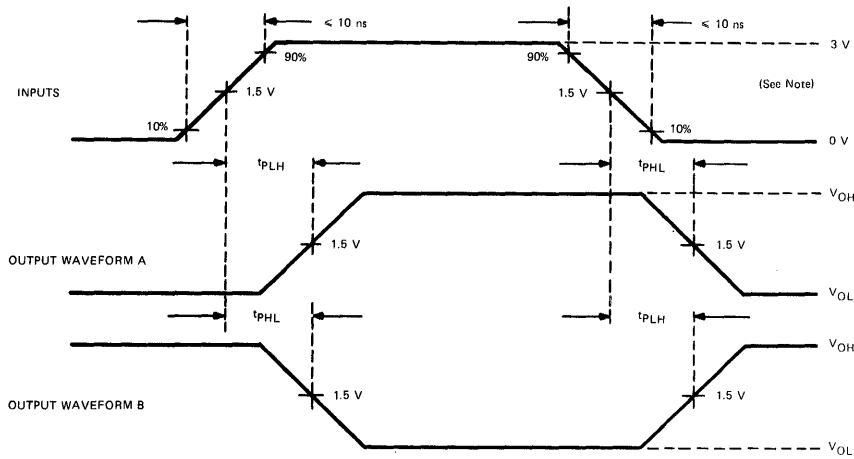

NOTE: The pulse generator has the following characteristics: PRR = 1 MHz, duty cycle = 50%, and $Z_{out} \approx 50 \Omega$.

VOLTAGE WAVEFORMS

TEST TABLE

INPUTS							OUTPUT Y WAVEFORM
B	A	C ₀	C ₁	C ₂	C ₃	G	
GND	GND	INPUT	X	X	X	GND	A
GND	4.5V	X	INPUT	X	X	GND	A
4.5V	GND	X	X	INPUT	X	GND	A
4.5V	4.5V	X	X	X	INPUT	GND	A
GND	INPUT	GND	4.5V	X	X	GND	A
INPUT	GND	GND	X	4.5V	X	GND	A
GND	GND	4.5V	X	X	X	INPUT	B

X = irrelevant

Fig. A SWITCHING TIMES

TTL/MSI 93164/54164, 74164

8-BIT SERIAL TO PARALLEL CONVERTER

TO BE ANNOUNCED

DESCRIPTION — The 93164/54164, 74164 are 8-Bit Shift Registers with gated serial inputs and an asynchronous clear facility. The gated serial inputs (A and B) permit control over incoming data, as a LOW at either (or both) input(s) inhibits entry of the new data and resets the first flip-flop to the LOW level at the next clock pulse. A HIGH level input enables the other input which will then determine the state of the first flip-flop. Data at the serial inputs may be changed while the clock is HIGH, but only information meeting the setup requirements will be entered. Clocking occurs on the LOW to HIGH level transition of the clock input. All inputs are diode-clamped to minimize transmission-line effects and are buffered to present one TTL load.

PIN NAMES

CP Clock Pulse Input
 \overline{C}_L Clear Input
 A, B Serial Inputs
 Q_A to Q_H Parallel Outputs

LOADING

1 U.L.
 1 U.L.
 1 U.L.
 5 U.L.

1 Unit Load (U.L.) = 40 μ A HIGH/1.6mA LOW.

TRUTH TABLE
SERIAL INPUTS A AND B

INPUTS AT t_n		OUTPUT AT t_{n+1}
A	B	Q_A
H	H	H
L	H	L
H	L	L
L	L	L

LOGIC DIAGRAM

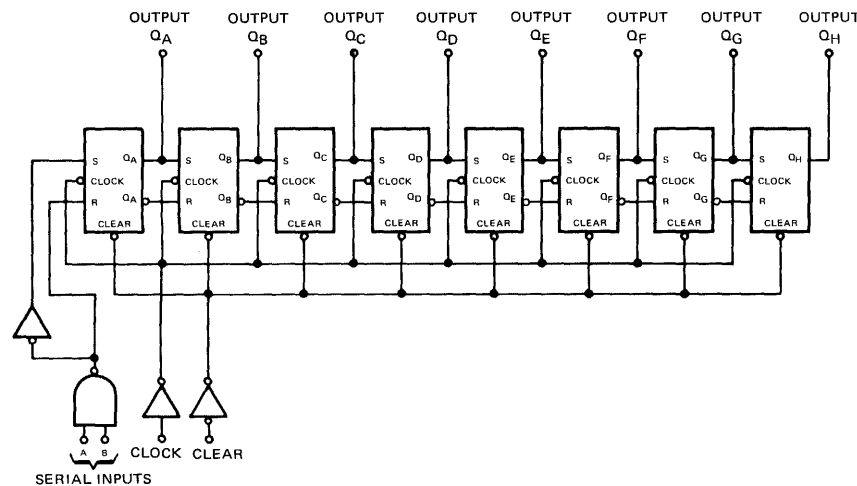

LOGIC SYMBOL

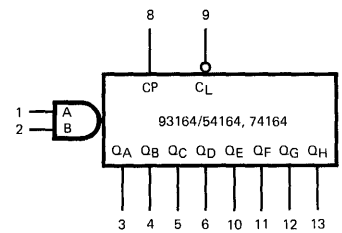

V_{CC} = Pin 14
 GND = Pin 7

CONNECTION DIAGRAMS
DIP (TOP VIEW)

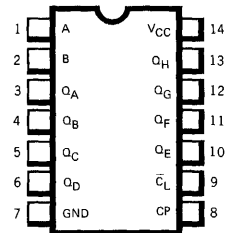

FLATPAK (TOP VIEW)

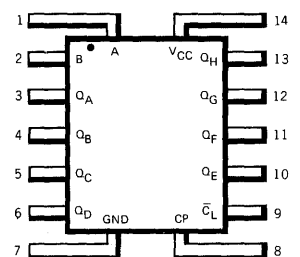

LOW input to clear resets all outputs to the LOW level.

TTL/MSI • 93164/54164, 74164

ABSOLUTE MAXIMUM RATINGS (above which the useful life may be impaired)

Storage Temperature	-65°C to +150°C
Temperature (Ambient) Under Bias	-55°C to +125°C
V _{CC} Pin Potential to Ground Pin	-0.5 V to +7.0 V
*Input Voltage (dc)	-0.5 V to +5.5 V
*Input Current (dc)	-30 mA to +5.0 mA
Voltage Applied to Outputs (Output HIGH)	-0.5 V to +V _{CC} value
Output Current (dc) (Output LOW)	+30 mA

*Either Input Voltage limit or Input Current limit is sufficient to protect the inputs.

RECOMMENDED OPERATING CONDITIONS

PARAMETER	93164XM/54164XM			93164XC/74164XC			UNITS
	MIN.	TYP.	MAX.	MIN.	TYP.	MAX.	
Supply Voltage V _{CC}	4.5	5.0	5.5	4.75	5.0	5.25	Volts
Operating Free-Air Temperature Range	-55	25	125	0	25	70	°C
Normalized Fan Out from Each Output, N	HIGH Logic Level		10			10	U.L.
	LOW Logic Level		5.0			5.0	
Input Clock Frequency, f _{CLOCK}	0		25	0		25	MHz
Width of Clock or Clear Input Pulse t _{PW}	20			20			ns
Data Setup Time, t _{setup} (See Fig. A)	15			15			ns
Data Hold Time, t _{HOLD} (See Fig. A)	0			0			ns

X=package type; F for Flatpak, D for Ceramic Dip, P for Plastic Dip. See packaging Information Section for packages available on this product.

ELECTRICAL CHARACTERISTICS OVER OPERATING TEMPERATURE RANGE (Unless Otherwise Noted)

SYMBOL	PARAMETER	LIMITS			UNITS	TEST CONDITIONS (Note 1)
		MIN.	TYP. (Note 2)	MAX.		
V _{IH}	Input HIGH Voltage	2.0			Volts	Guaranteed V _{IH}
V _{IL}	Input LOW Voltage			0.8	Volts	Guaranteed V _{IL}
V _{CD}	Input Clamp Diode Voltage			-1.5	Volts	V _{CC} = MAX., I _{IN} = -12 mA
V _{OH}	Output HIGH Voltage	2.4			Volts	V _{CC} = MIN., I _{OH} = -0.4 mA, V _{IH} = 2.0 V, V _{IL} = 0.8 V
V _{OL}	Output LOW Voltage			0.4	Volts	V _{CC} = MIN., I _{OL} = 8.0 mA, V _{IH} = 2.0 V, V _{IL} = 0.8 V
I _I	Input Current at Maximum Input Voltage			1.0	mA	V _{CC} = MAX., V _{IN} = 5.5 V
I _{IH}	Input HIGH Current			40	μA	V _{CC} = MAX., V _{IN} = 2.4 V
I _{IL}	Input LOW Current			-1.6	mA	V _{CC} = MAX., V _{IN} = 0.4 V
I _{OS}	Output Short Circuit Current (Note 3)	-10		-27.5	mA	93164/54164
		-9.0		-27.5	mA	93164/74164
I _{CC}	Supply Current		30		mA	V _{IN} (clock) = 0.4V
			37	54	mA	V _{IN} (clock) = 2.4V

SWITCHING CHARACTERISTICS (T_A = 25°C)

SYMBOL	PARAMETER	LIMITS			UNITS	TEST CONDITIONS
		MIN.	TYP.	MAX.		
f _{max}	Maximum Input Count Frequency	25	36		MHz	V _{CC} = 5.0 V R _L = 800Ω (See Fig. A)
t _{PHL}	Turn On Delay Clear to Outputs		24	36	ns	
			28	42		
t _{PLH}	Turn Off Delay Clock to Outputs	8.0	17	27	ns	
		10	20	30		
t _{PHL}	Turn On Delay Clock to Outputs	10	21	32	ns	
		10	25	37		

NOTES:

- (1) For conditions shown as MIN. or MAX., use the appropriate value specified under recommended operating conditions for the applicable device type.
- (2) Typical limits are at V_{CC} = 5.0 V, 25°C.
- (3) Not more than two outputs should be shorted at a time.
- (4) Measured with outputs open, serial inputs grounded, and a momentary ground, then 4.5 V, applied to clear.



TYPICAL CLEAR, INHIBIT, SHIFT, CLEAR AND INHIBIT SEQUENCES

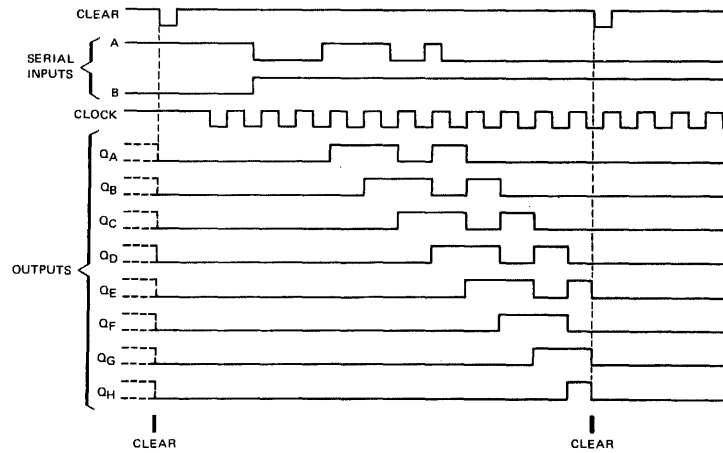

PARAMETER MEASUREMENT INFORMATION

SWITCHING CHARACTERISTICS

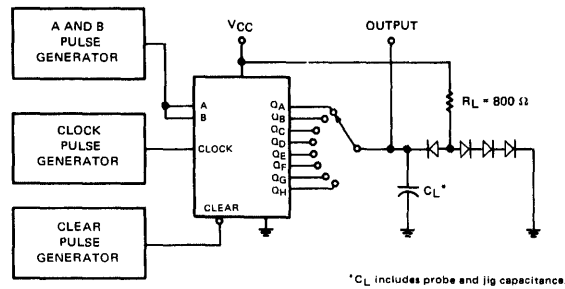

TEST CIRCUIT

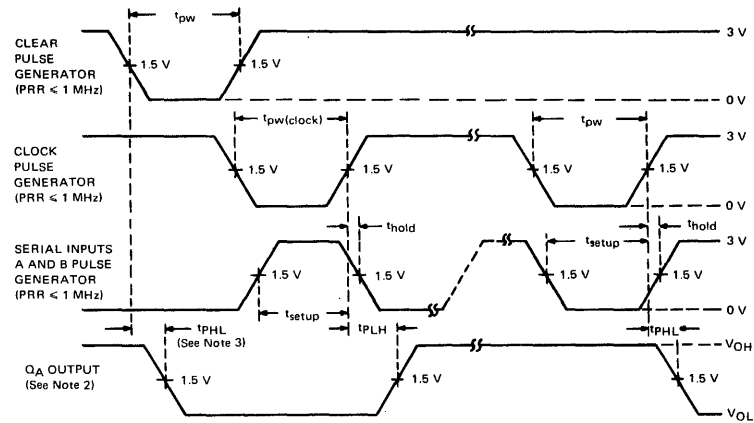

VOLTAGE WAVEFORMS

NOTES:

1. The pulse generators have the following characteristics: $t_r \leq 10\text{ns}$, $t_f \leq 10\text{ns}$, duty cycle $\leq 50\%$, $Z_{OUT} = 50\Omega$.
2. Q_A output is illustrated. Relationship of serial input A and B data to other Q outputs is illustrated in the typical shift sequence.
3. Outputs are set to the HIGH level prior to the measurement of t_{PHL} from the clear input.

Fig. A SWITCHING TIMES

TTL/MSI 93165/54165, 74165

8-BIT PARALLEL TO SERIAL CONVERTER

DESCRIPTION — The 93165/54165, 74165 is an 8-Bit Serial Shift Register which features parallel-in access to each stage, gated clock input, complementary outputs from the last stage and input clamp diodes. Parallel-in access to each stage is made possible by eight individual direct data inputs which are enabled by a LOW level at the shift/load input.

Clocking is accomplished through a 2-input positive-NOR gate, permitting one input to be used as a clock-inhibit function. Holding either of the clock inputs HIGH inhibits clocking, and holding either clock input LOW with the load input HIGH enables the other clock input. The clock-inhibit input should be changed to the HIGH level only while the clock input is HIGH. Parallel loading is inhibited as long as the load input is HIGH. When taken LOW, data at the parallel inputs are loaded directly into the register independently of the state of the clock.

Typical power dissipation is 210 mW and maximum input clock frequency is typically 26 MHz.

PIN NAMES

A to H	Parallel Inputs
S _I	Serial Input
CP	Clock Input
S _L	Shift Load
CLOCK INHIBIT	Clock Inhibit
Q _H , \bar{Q}_H	Outputs

LOADING

1 U.L.
1 U.L.
1 U.L.
2 U.L.
1 U.L.
10 U.L.

NOTE: 1 U.L. = 40 μ A HIGH/1.6 mA LOW.

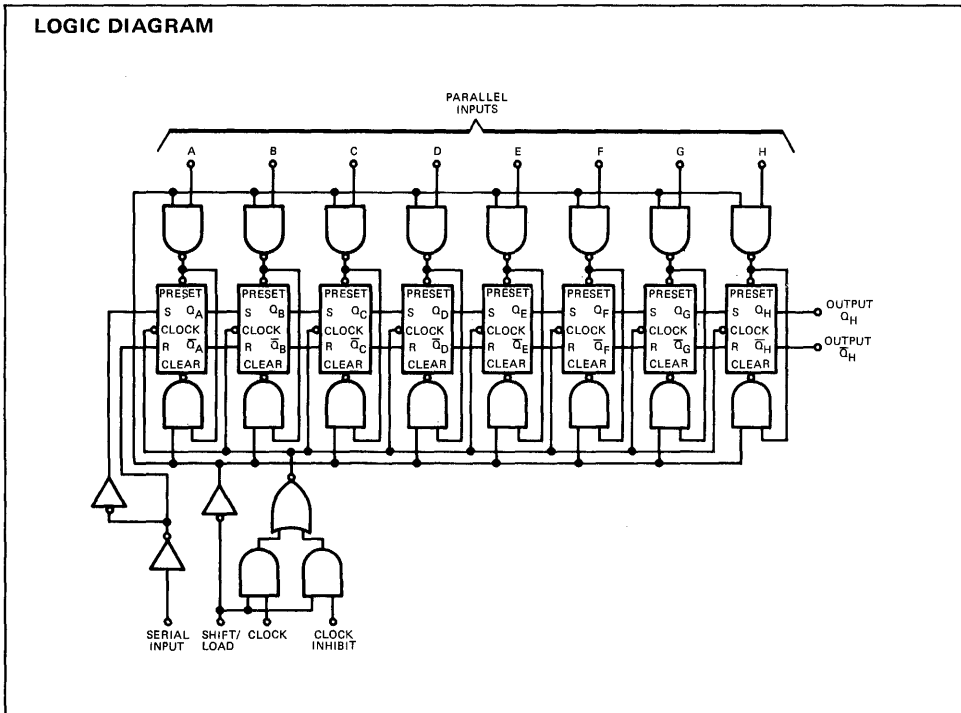
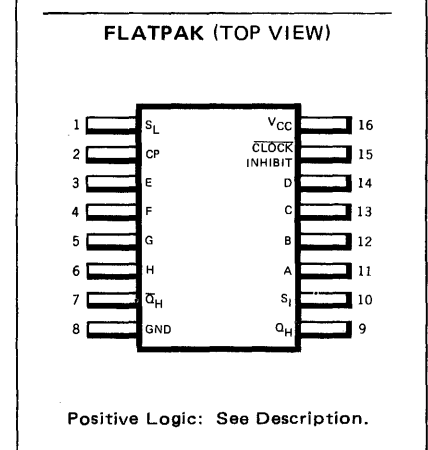
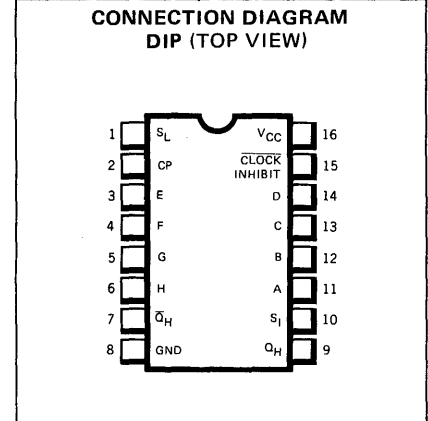
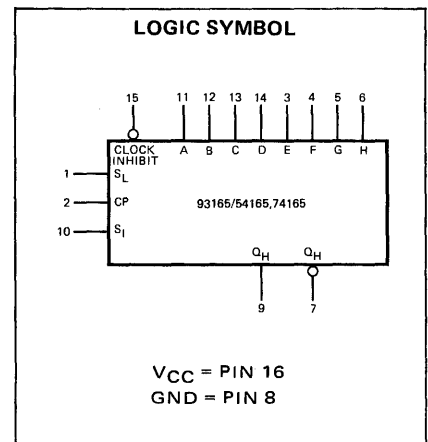

TTL/MSI • 93165/54165, 74165

ABSOLUTE MAXIMUM RATINGS (above which the useful life may be impaired)

Storage Temperature	-65°C to +150°C
Temperature (Ambient) Under Bias	-55°C to +125°C
V _{CC} Pin Potential to Ground Pin	-0.5 V to +7.0 V
*Input Voltage (dc)	-0.5 V to +5.5 V
*Input Current (dc)	-30 mA to +5.0 mA
Voltage Applied to Outputs (Output HIGH)	-0.5 V to +V _{CC} value
Output Current (dc) (Output LOW)	+30 mA

*Either Input Voltage limit or Input Current limit is sufficient to protect the inputs.

RECOMMENDED OPERATING CONDITIONS

PARAMETER	93165XM/54165XM			93165XC/74165XC			UNITS
	MIN.	TYP.	MAX.	MIN.	TYP.	MAX.	
Supply Voltage V _{CC}	4.5	5.0	5.5	4.75	5.0	5.25	Volts
Operating Free-Air Temperature Range	-55	25	125	0	25	70	°C
Normalized Fan Out from Each Output, N	HIGH Level		20			20	U.L.
	LOW Level		10			10	
Input clock frequency, f _{clock}	0		20	0		20	MHz
Width of clock input pulse, t _{w(clock)}	25			25			ns
Width of load input pulse, t _{w(load)}	15			15			ns
Clock-enable setup time, t _{setup} (See Fig. 1)	30			30			ns
Parallel input setup time, t _{setup} (See Fig. 1)	10			10			ns
Serial input setup time, t _{setup} (see Fig. 2)	20			20			ns
Shift setup time, t _{setup} (See Fig. 2)	45			45			ns
Hold time at any input, t _{hold}	0			0			ns

X=package type; F for Flatpak, D for Ceramic Dip, P for Plastic Dip. See Packaging Information Section for packages available on this product.

ELECTRICAL CHARACTERISTICS OVER OPERATING TEMPERATURE RANGE (Unless Otherwise Noted)

SYMBOL	PARAMETER	LIMITS			UNITS	TEST CONDITIONS (Note 1)
		MIN.	TYP. (Note 2)	MAX.		
V _{IH}	Input HIGH Voltage	2.0			Volts	Guaranteed Input HIGH Threshold Voltage
V _{IL}	Input LOW Voltage			0.8	Volts	Guaranteed Input LOW Threshold Voltage
V _{CD}	Input Clamp Diode Voltage			-1.5	Volts	V _{CC} = MAX., I _{IN} = -12 mA
V _{OH}	Output HIGH Voltage	2.4			Volts	V _{CC} = MIN., I _{OH} = -800 μA, V _{IH} = 2.0 V, V _{IL} = 0.8 V
V _{OL}	Output LOW Voltage			0.4	Volts	V _{CC} = MIN., I _{OL} = 16 mA, V _{IH} = 2.0 V, V _{IL} = 0.8 V
I _I	Input Current at MAX. Input Voltage			1.0	mA	V _{CC} = MAX., V _{IN} = 5.5 V
I _{IH}	Input HIGH Current	Other Inputs		40	μA	V _{CC} = MAX., V _{IN} = 2.4 V
		Load Inputs		80		
I _{IL}	Input LOW Current	Other Inputs		-1.6	mA	V _{CC} = MAX., V _{IN} = 0.4 V
		Load Inputs		-3.2		
I _{OS}	Output Short Circuit Current (Note 3)	-20		-55	mA	93165/54165
		-18		-55	mA	93165/74165
I _{CC}	Supply Current (Note 4)		42	63	mA	V _{CC} = MAX.

NOTES:

- (1) For conditions shown as MIN. or MAX., use the appropriate value specified under recommended operating conditions for the applicable device type.
- (2) Typical limits are at V_{CC} = 5.0 V, 25°C.
- (3) Not more than one output should be shorted at a time.
- (4) With the outputs open, clock inhibit and shift/load at 4.5 V, and a clock pulse applied to the clock input, I_{CC} is measured first with the parallel inputs at 4.5 V, then with the parallel inputs grounded.

SWITCHING CHARACTERISTICS (T_A = 25°C)

SYMBOL	PARAMETER	LIMITS			UNITS	TEST CONDITIONS
		MIN.	TYP.	MAX.		
f _{max}	Max. Input Count Frequency	20	26		MHz	V _{CC} = 5.0 V C _L = 15 pF R _L = 400Ω (See Figs. 1 Thru 3)
t _{PLH}	Load Input to Any Output		21	31	ns	
t _{PHL}			27	40		
t _{PLH}	Clock Input to Any Output		16	24	ns	
t _{PHL}			21	31		
t _{PLH}	H Input to Q _H Output		11	17	ns	
t _{PHL}			24	36		
t _{PLH}	H Input to Q̄ _H Output		18	27	ns	
t _{PHL}			18	27		

TYPICAL SHIFT, LOAD, AND INHIBIT SEQUENCES

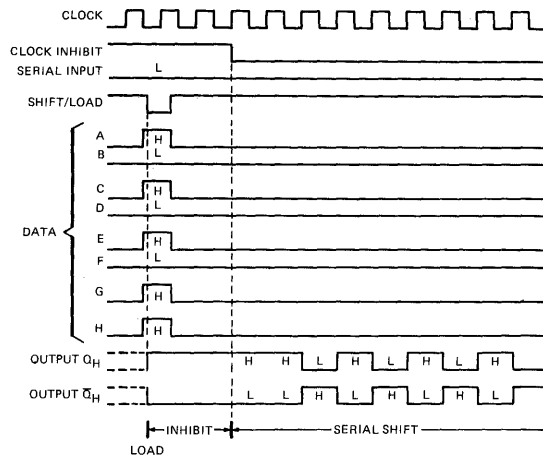

PARAMETER MEASUREMENT INFORMATION

SWITCHING CHARACTERISTICS

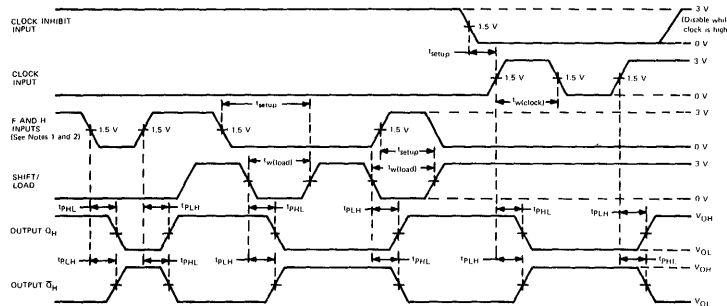

NOTES:

1. The remaining six data inputs and the serial input are LOW.
2. Prior to test, HIGH level data is loaded into H input.
3. The input pulse generators have the following characteristics:
t_r ≤ 10 ns, t_f ≤ 10 ns, PRR ≤ 1 MHz, duty cycle ≤ 50%, Z_{out} ≈ 50 Ω. When testing f_{max}, vary clock PRR.

Fig. 1 VOLTAGE WAVEFORMS

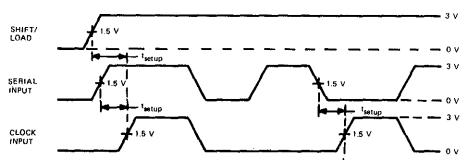

NOTES:

1. The eight data inputs and the clock-inhibit input are LOW. Results are monitored at output Q_H at t_n + 7.
2. The inputs pulse generators have the following characteristics:
t_r ≤ 10 ns, t_f ≤ 10 ns, PRR ≤ 1 MHz, duty cycle ≤ 50%, Z_{out} ≈ 50 Ω.

Fig. 2 VOLTAGE WAVEFORMS

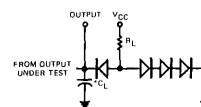

*C_L includes probe and jig capacitance.

Fig. 3 LOAD CIRCUIT FOR SWITCHING TESTS

TTL/MSI 93176/54176, 74176 93177/54177, 74177 BCD DECADE/4-BIT BINARY COUNTER

TO BE ANNOUNCED

DESCRIPTION – The 93176/54176, 74176 is a Decade Counter that can be connected in BCD counting mode, in a divide-by-two and divide-by-five configuration, or in the bi-quinary mode. The 93177/54177, 74177 can be connected as a divide-by-two, eight, or sixteen counter. Both counters feature strobed parallel-entry capability. A LOW at the Data Strobe inputs transfers the data at the parallel inputs to the outputs. Each counter is provided with a reset input, which when LOW resets the outputs to LOW state. The counting operation is performed on the negative going edge of the clock pulse.

LOGIC DIAGRAM

93176/54176, 74176

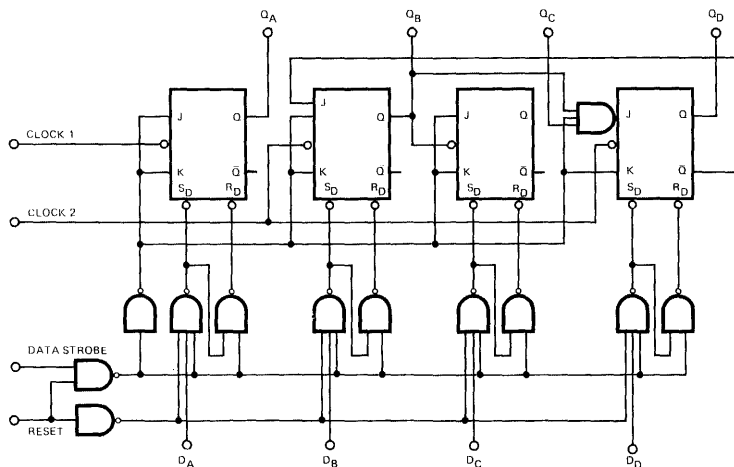

93177/54177, 74177

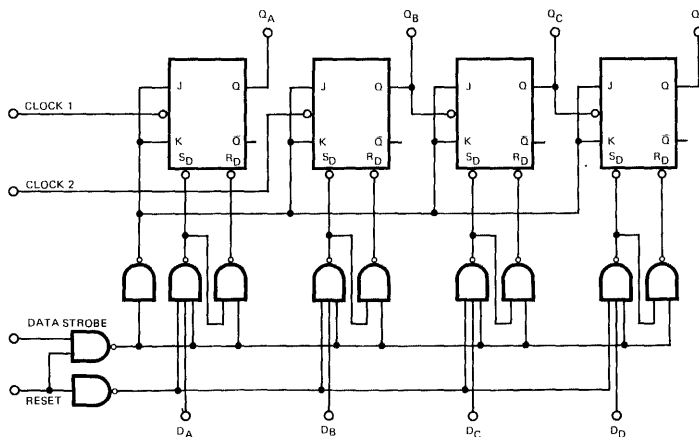

LOGIC SYMBOL

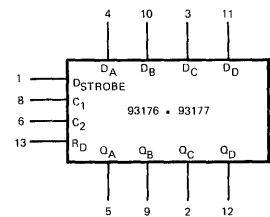

Pin numbers are shown for DIP only.

CONNECTION DIAGRAMS DIP (TOP VIEW)

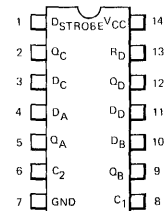

FLATPAK (TOP VIEW)

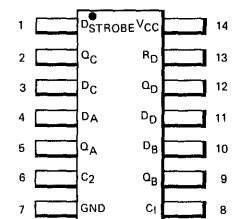

TTL/MSI 93178/54178, 74178

93179/54179, 74179

4-BIT SHIFT REGISTERS

TO BE ANNOUNCED

DESCRIPTION — The 93178 and 93179 are 4-Bit Shift Registers with both serial and parallel data entry capability. The 93179 features a direct reset (R_D), and a \bar{D}_{out} line in addition to the available outputs of the 93178. The truth table below indicates the three possible control states: shift right, parallel entry and hold. The clock line is buffered to minimize input clock loading. All changes occur on the negative-going clock transition. Since data transfer is synchronous with the clock, data may be transferred in any serial/parallel input/output relationship.

TRUTH TABLE

CONTROL STATE	LOAD	SHIFT
Hold	L	L
Parallel Entry	H	L
Shift Right	L	H
Shift Right	H	H

LOGIC DIAGRAM

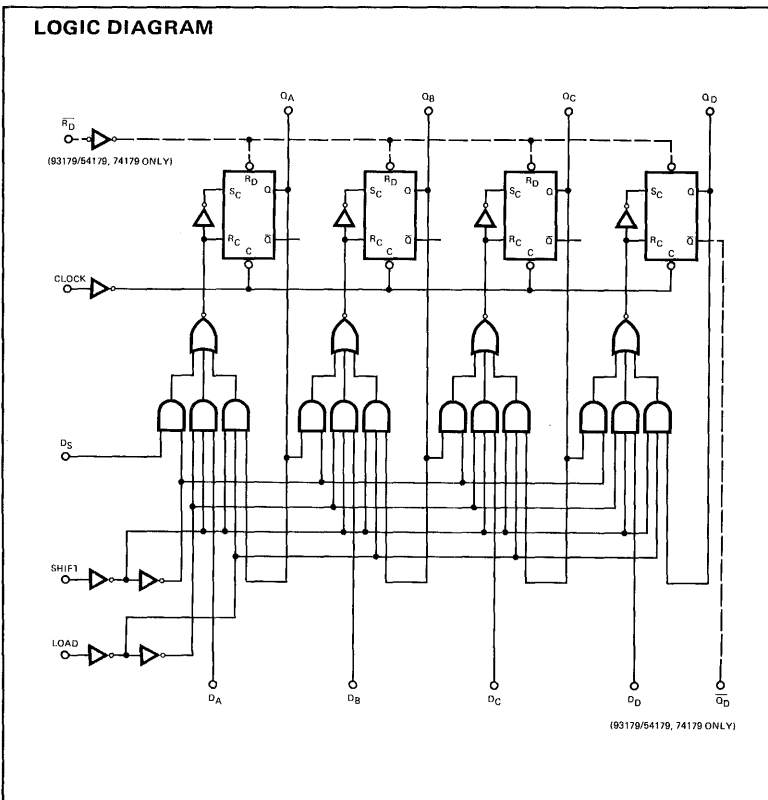

LOGIC SYMBOL

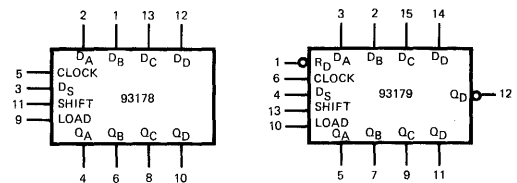

Pin numbers are shown for DIP only.

**CONNECTION DIAGRAM
DIP (TOP VIEW)**

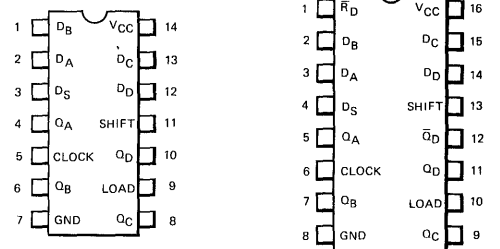

93178/54178, 74178

93179/54179, 74179

FLATPAK (TOP VIEW)

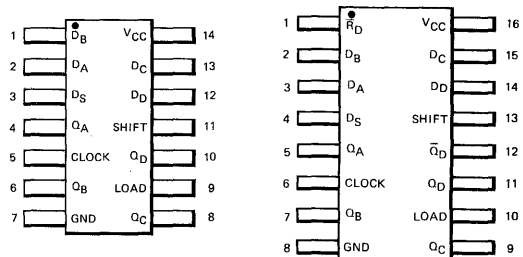

93178/54178, 74178

93179/54179, 74179

TTL/MSI 93180/54180, 74180

8-BIT PARITY GENERATOR/CHECKER

DESCRIPTION — The 93180/54180 or 74180 are monolithic, 8-Bit Parity Check/Generators which feature control inputs and even/odd outputs to enhance operation in either odd or even parity applications. Cascading these circuits allows unlimited word length expansion. Typical application would be to generate and check parity on data being transmitted from one register to another. Typical power dissipation is 170 mW.

As with all Fairchild TTL products, all inputs are diode-clamped to minimize transmission-line effects and simplify system design.

PIN NAMES

I_0 to I_7 Parity Inputs
 P_0 Odd Parity Input
 P_E Even Parity Input
 ΣQ_0 Sum Odd Outputs
 ΣQ_E Sum Even Outputs

LOADING

1 U.L.
 2 U.L.
 2 U.L.
 10 U.L.
 10 U.L.

Note: 1 U.L. = 40 μ A HIGH/1.6 mA LOW

TRUTH TABLE

INPUTS			OUTPUTS	
Σ OF 1's AT 0 THRU 7	EVEN	ODD	Σ EVEN	Σ ODD
EVEN	H	L	H	L
ODD	H	L	L	H
EVEN	L	H	L	H
ODD	L	H	H	L
X	H	H	L	L
X	L	L	H	H

X = irrelevant

LOGIC DIAGRAM

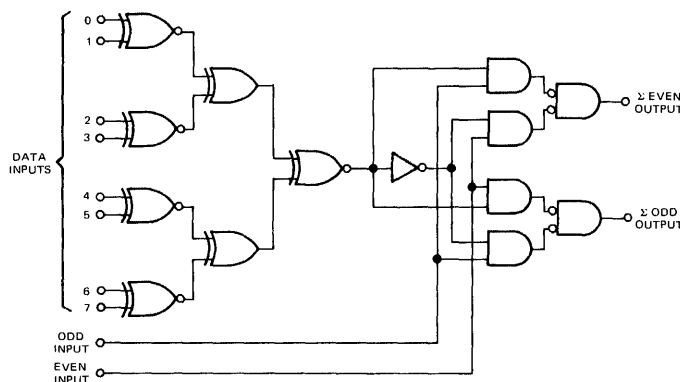

LOGIC SYMBOL

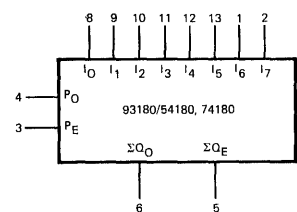

V_{CC} = Pin 14
 GND = Pin 7

CONNECTION DIAGRAM DIP (TOP VIEW)

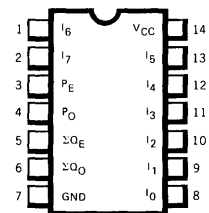

FLATPAK (TOP VIEW)

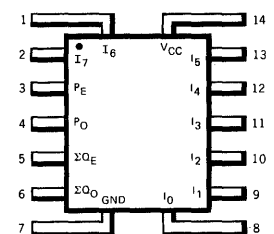

Positive logic: See truth table.

TTL/MSI • 93180/54180, 74180

ABSOLUTE MAXIMUM RATINGS (above which the useful life may be impaired)

Storage Temperature	-65°C to +150°C
Temperature (Ambient) Under Bias	-55°C to +125°C
V _{CC} Pin Potential to Ground Pin	-0.5 V to +7.0 V
*Input Voltage (dc)	-0.5 V to +5.5 V
*Input Current (dc)	-30 mA to +5.0 mA
Voltage Applied to Outputs (Output HIGH)	-0.5 V to +V _{CC} value
Output Current (dc) (Output LOW)	+30 mA

*Either Input Voltage limit or Input Current limit is sufficient to protect the inputs.

RECOMMENDED OPERATING CONDITIONS

PARAMETER	93180XM/54180XM			93180XC/74180XC			UNITS
	MIN.	TYP.	MAX.	MIN.	TYP.	MAX.	
Supply Voltage V _{CC} (See Note 4)	4.5	5.0	5.5	4.75	5.0	5.25	Volts
Operating Free-Air Temperature Range	-55	25	125	0	25	70	°C
Normalized Fan Out from Each Output, N	LOW Level		10			10	U.L.
	HIGH Level		20			20	

X=package type; F for Flatpak, D for Ceramic Dip, P for Plastic Dip. See packaging Information Section for packages available on this product.

ELECTRICAL CHARACTERISTICS OVER OPERATING TEMPERATURE RANGE (Unless Otherwise Noted)

SYMBOL	PARAMETER	LIMITS			UNITS	TEST CONDITIONS (Note 1)	TEST FIGURE
		MIN.	TYP. (Note 2)	MAX.			
V _{IH}	Input HIGH Voltage	2.0			Volts	Guaranteed Input HIGH Voltage	1
V _{IL}	Input LOW Voltage			0.8	Volts	Guaranteed Input LOW Voltage	1
V _{OH}	Output HIGH Voltage	2.4			Volts	V _{CC} = MIN., I _{OH} = -800 μA, V _{IH} = 2.0 V, V _{IL} = 0.8 V	1
V _{OL}	Output LOW Voltage			0.4	Volts	V _{CC} = MIN., I _{OL} = 16 mA, V _{IH} = 2.0 V, V _{IL} = 0.8 V	1
I _{IH}	Input HIGH Current at Each Data Input			40	μA	V _{CC} = MAX., V _{IN} = 2.4 V	2
				1.0	mA	V _{CC} = MAX., V _{IN} = 5.5 V	
I _{IH}	Input HIGH Current at Even or Odd Input			80	μA	V _{CC} = MAX., V _{IN} = 2.4 V	2
				1.0	mA	V _{CC} = MAX., V _{IN} = 5.5 V	
I _{IL}	Input LOW Current at Each Data Input			-1.6	mA	V _{CC} = MAX., V _{IN} = 0.4 V	2
I _{IL}	Input LOW Current at Even or Odd Input			-3.2	mA	V _{CC} = MAX., V _{IN} = 0.4 V	2
I _{OS}	Output Short Circuit Current (Note 3)	-20		-55	mA	93180/54180	V _{CC} = MAX. 3
		-18		-55	mA	93180/74180	
I _{CC}	Supply Current		34	49	mA	93180/74180	V _{CC} = MAX. 3 & 4
			34	56	mA	93180/54180	

SWITCHING CHARACTERISTICS (T_A = 25°C)

SYMBOL	PARAMETER	LIMITS			UNITS	TEST CONDITIONS	TEST FIGURE
		MIN.	TYP.	MAX.			
t _{PLH}	Data Input to		40	60	ns	V _{CC} = 5.0 V C _L = 15 pF R _L = 400Ω	A
t _{PHL}	Σ Even Output		45	68			
t _{PLH}	Data Input to		32	48	ns	R _L = 400Ω Odd Input Ground	A
t _{PHL}	Σ Odd Output		25	38			
t _{PLH}	Data Input to		32	48	ns	V _{CC} = 5.0 V C _L = 15 pF R _L = 400Ω	A
t _{PHL}	Σ Even Output		25	38			
t _{PLH}	Data Input to		40	60	ns	R _L = 400Ω Even Input Ground	A
t _{PHL}	Σ Odd Output		45	68			
t _{PLH}	Even or Odd Input to		13	20	ns	V _{CC} = 5.0 V C _L = 15 pF R _L = 400Ω	A
t _{PHL}	Σ Even or Σ Odd Output		7.0	10			

NOTES

- (1) For conditions shown as MIN. or MAX., use the appropriate value specified under recommended operating conditions for the particular circuit type.
- (2) Typical limits are at V_{CC} = 5.0 V, 25°C.
- (3) Not more than one output should be shorted at a time.
- (4) These voltage values are with respect to network ground terminal.

PARAMETER MEASUREMENT INFORMATION

dc TEST CIRCUITS*

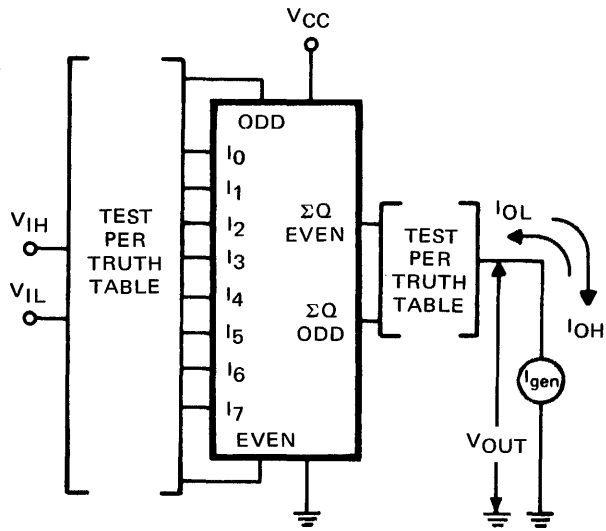
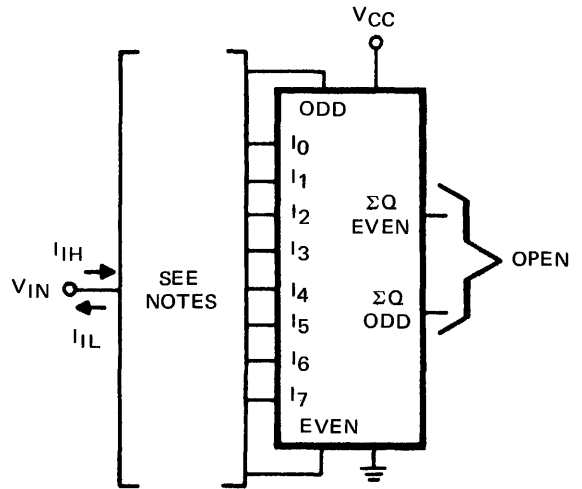

Fig. 1



NOTES:

1. Each output is tested separately.
2. Odd and even inputs are each tested for I_{IH} and I_{IL} with both an even-code and an odd-code applied at the data inputs.

Fig. 2

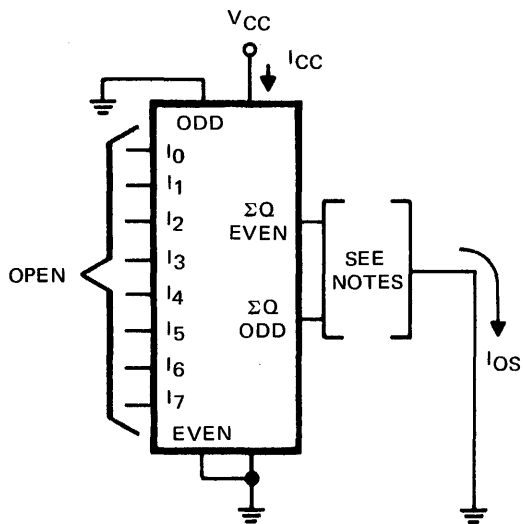

NOTES:

1. Each output is tested separately.
2. When testing I_{CC} both outputs are open.

Fig. 3

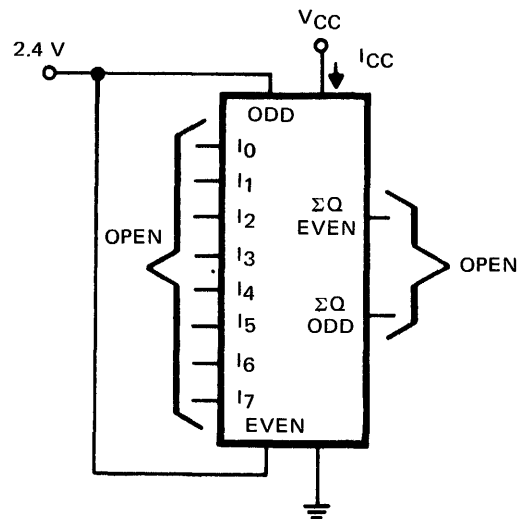
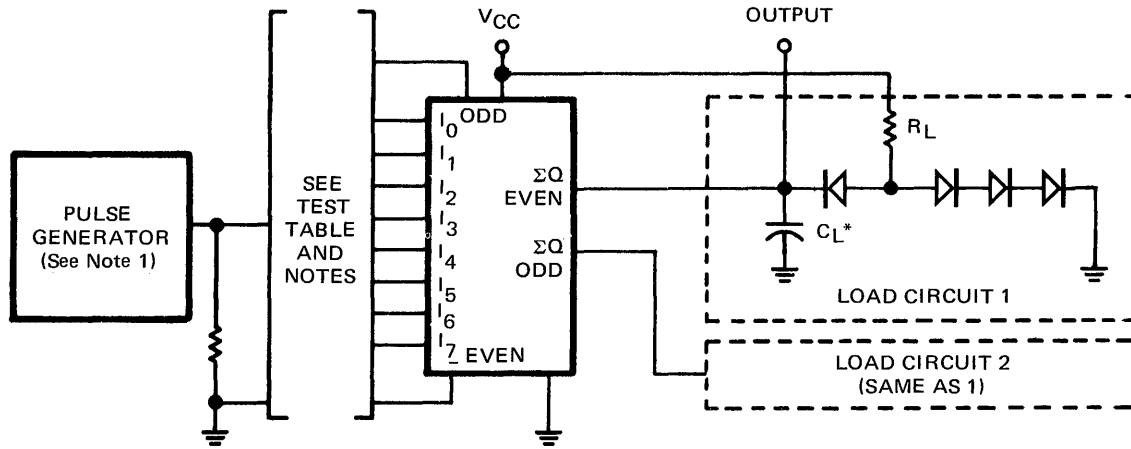

Fig. 4

PARAMETER MEASUREMENT INFORMATION (con't)

SWITCHING CHARACTERISTICS



* C_L includes probe and jig capacitance.

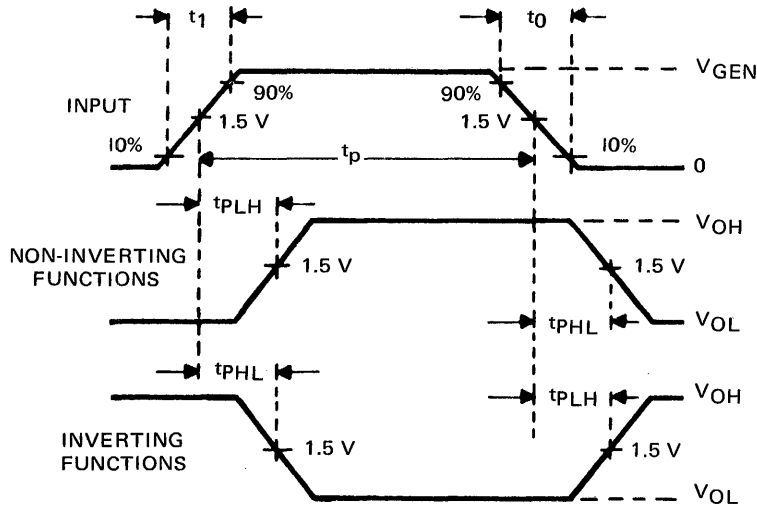

VOLTAGE WAVEFORMS

NOTES:

- The pulse generator has the following characteristics: $V_{gen} = 3V$, $t_1 = t_0 = 10\text{ ns}$, $t_p = 500\text{ ns}$, $PRR = 1\text{ MHz}$, and $Z_{OUT} \approx 50\ \Omega$.
- Inputs not specified are open.

TEST TABLE†

INPUT CONDITIONS		OUTPUT TESTED
APPLY PULSE	GND	
0	ODD	Σ EVEN
1	ODD	Σ EVEN
2	ODD	Σ EVEN
3	ODD	Σ EVEN
4	ODD	Σ EVEN
5	ODD	Σ EVEN
6	ODD	Σ EVEN
7	ODD	Σ EVEN
0	ODD	Σ ODD
1	ODD	Σ ODD
2	ODD	Σ ODD
3	ODD	Σ ODD
4	ODD	Σ ODD
5	ODD	Σ ODD
6	ODD	Σ ODD
7	ODD	Σ ODD
EVEN	0	Σ EVEN
ODD	NONE	Σ EVEN
EVEN	NONE	Σ ODD
ODD	0	Σ ODD

† Repeat all but the last 4 tests with the even input grounded.

Fig. A – SWITCHING TIMES

TTL/MSI 93H183/54H183, 74H183

HIGH SPEED DUAL CARRY/SAVE FULL ADDER

DESCRIPTION — The 93H183/54H183, 74H183 features two independent, high speed, Full Adders. Typical average sum and carry propagation delay times are 11 ns. Each adder has an individual carry output from each bit for use in multiple-input, carry/save techniques to produce the true sum and true carry outputs.

PIN NAMES

1A, 1B, 1C_n, 2A, 2B, 2C_n
1C_{n+1}, 1Σ, 2C_{n+1}, 2Σ

Inputs
Outputs (Note b)

LOADING (Note a)

3.75 U.L.
12.5 U.L.

NOTES:

- 1 Unit Load (U.L.) = 40 μA HIGH/1.6 mA LOW.
- 12.5 U.L. is the LOW drive factor and 25 U.L. is the HIGH drive factor.

TRUTH TABLE

INPUTS			OUTPUTS	
C _n	B	A	Σ	C _{n+1}
L	L	L	L	L
L	L	H	H	L
L	H	L	H	L
L	H	H	L	H
H	L	L	H	L
H	L	H	L	H
H	H	L	L	H
H	H	H	H	H

LOGIC DIAGRAM (EACH ADDER)

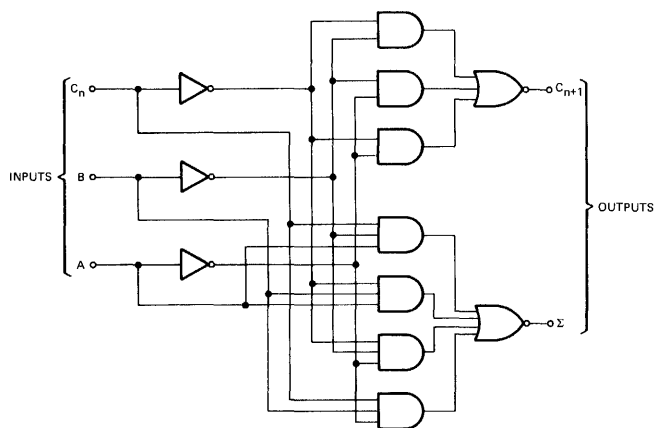

LOGIC SYMBOL

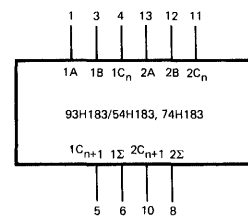

V_{CC} = Pin 14
GND = Pin 7

CONNECTION DIAGRAMS DIP (TOP VIEW)

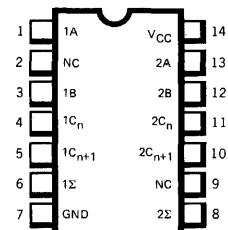

FLATPAK (TOP VIEW)

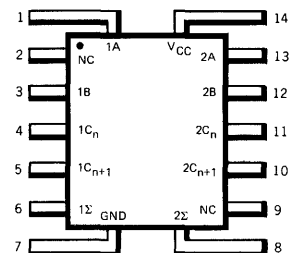

NC — No internal connection
Positive logic: See truth table

HIGH SPEED TTL/MSI • 93H183/54H183, 74H183

ABSOLUTE MAXIMUM RATINGS (above which the useful life may be impaired)

Storage Temperature	-65°C to +150°C
Temperature (Ambient) Under Bias	-55°C to +125°C
V _{CC} Pin Potential to Ground Pin	-0.5 V to +7.0 V
*Input Voltage (dc)	-0.5 V to +5.5 V
*Input Current (dc)	-30 mA to +5.0 mA
Voltage Applied to Outputs (Output HIGH)	-0.5 V to +V _{CC} value
Output Current (dc) (Output LOW)	+30 mA

*Either Input Voltage limit or Input Current limit is sufficient to protect the inputs.

RECOMMENDED OPERATING CONDITIONS

PARAMETER	93H183XM/54H183XM			93H183XC/74H183XC			UNITS
	MIN.	TYP.	MAX.	MIN.	TYP.	MAX.	
Supply Voltage V _{CC} (See Note 4)	4.5	5.0	5.5	4.75	5.0	5.25	Volts
Operating Free-Air Temperature Range	-55	25	125	0	25	70	°C

X=package type; F for Flatpak, D for Ceramic Dip, P for Plastic Dip. See Packaging Information Section for packages available on this product.

ELECTRICAL CHARACTERISTICS OVER OPERATING TEMPERATURE RANGE (Unless Otherwise Noted)

SYMBOL	PARAMETER	LIMITS			UNITS	TEST CONDITIONS (Note 1)	TEST FIGURE
		MIN.	TYP. (Note 2)	MAX.			
V _{IH}	Input HIGH Voltage	2.0			Volts	Guaranteed Input HIGH Threshold Voltage	1
V _{IL}	Input LOW Voltage			0.8	Volts	Guaranteed Input LOW Threshold Voltage	2
V _{OH}	Output HIGH Voltage	2.4			Volts	V _{CC} = MIN., I _{OH} = -1 mA, V _{IH} = 2.0 V	1
V _{OL}	Output LOW Voltage			0.4	Volts	V _{CC} = MIN., I _{OL} = 20 mA, V _{IL} = 0.8 V	2
I _{IH}	Input HIGH Current			150	μA	V _{CC} = MAX., V _{IN} = 2.4 V	Any Input
I _{IL}	Input LOW Current			1.0	mA	V _{CC} = MAX., V _{IN} = 5.5 V	
I _{OS}	Output Short Circuit Current (Note 3)	-40		-100	mA	V _{CC} = MAX.	4
I _{CCH}	Supply Current HIGH		40		mA	V _{CC} = MAX., V _{IN} = 4.5 V, All Outputs HIGH	5
I _{CCL}	Supply Current LOW		48	69	mA	93H183/54H183	V _{CC} = MAX., V _{IN} = 0 V All Outputs LOW
			48	75	mA	93H183/74H183	

SWITCHING CHARACTERISTICS (T_A = 25°C)

SYMBOL	PARAMETER	LIMITS			UNITS	TEST CONDITIONS	TEST FIGURE
		MIN.	TYP.	MAX.			
t _{PLH}	Turn Off Delay Input to Output		10	15	ns	V _{CC} = 5.0 V C _L = 25 pF R _L = 280Ω	A
t _{PHL}	Turn On Delay Input to Output		12	18	ns		

NOTES:

- (1) For conditions shown as MIN. or MAX., use the appropriate value specified under recommended operating conditions for the applicable device type.
- (2) Typical limits are at V_{CC} = 5.0 V, 25°C.
- (3) Not more than one output should be shorted at a time, and duration of short-circuit test should not exceed 1 second.
- (4) Voltage values, except interemitter voltage, are with respect to network ground terminal.

PARAMETER MEASUREMENT INFORMATION

DC TEST CIRCUITS*

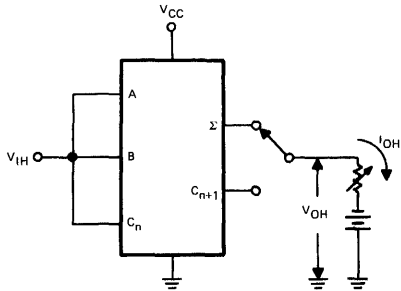

Each output is tested separately.

Fig. 1 - V_{IH}, V_{OH}

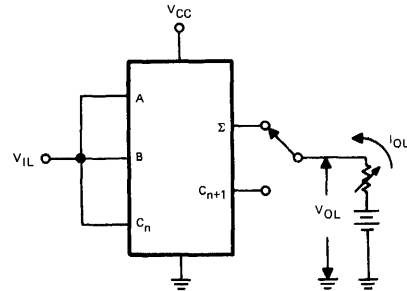

Each output is tested separately.

Fig. 2 - V_{IL}, V_{OL}

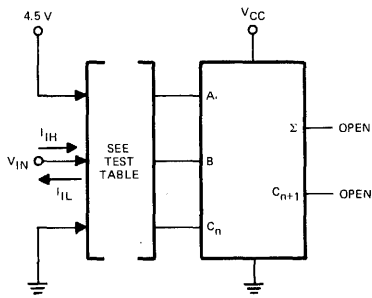

Each input is tested for both combinations of states of the other inputs.

Fig. 3 - I_{IH}, I_{IL}

TEST TABLE

APPLY V_{IN} , MEASURE I_{IH}/I_{IL}	CONDITIONS ON OTHER INPUTS	
	4.5 V	GND
A	B, C_n	NONE
B	B	C_n
	C_n	B
	NONE	B, C_n
C_n	A, C_n	NONE
	A	C_n
	NONE	A
A	NONE	A, C_n
	A, B	NONE
	A	B
B	B	A
	NONE	A, B

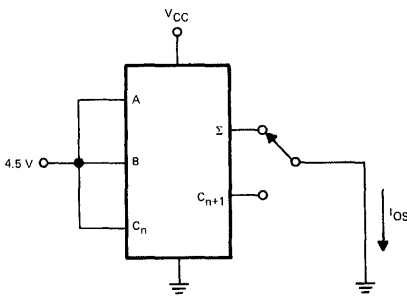

Each output is tested separately.

Fig. 4 - I_{OS}

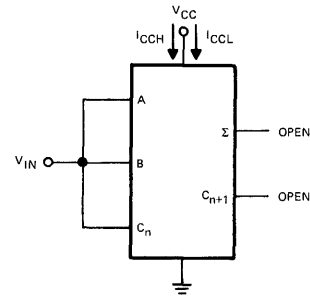

Both adders are tested simultaneously.

Fig. 5 - I_{CCH}, I_{CCL}

*Arrows indicate actual direction of current flow. Current into a terminal is a positive value.

PARAMETER MEASUREMENT INFORMATION

SWITCHING CHARACTERISTICS

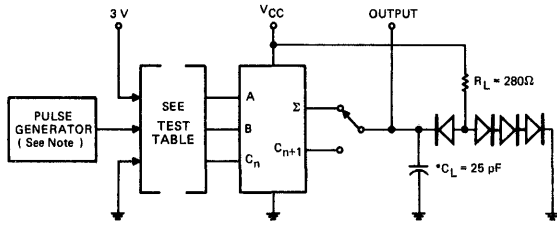

* C_L includes probe and jig capacitance.

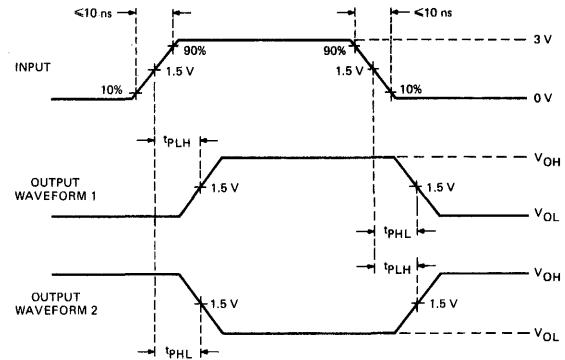

NOTE:

The generator has the following characteristics: PRR = 1 MHz, $Z_{out} \approx 50\Omega$.

TEST CIRCUIT

VOLTAGE WAVEFORMS

Fig. A – SWITCHING TIMES

TEST TABLE FOR FIG. A (EACH ADDER)

TEST NO.	PARAMETER	APPLY PULSE GENERATOR	APPLY 3V	APPLY GND	OUTPUT UNDER TEST	OUTPUT WAVEFORM
1	tPLH	A	B, C _n		Σ	1
2	tPHL	A	B	C _n	Σ	2
3	tPLH	A	C _n	B	Σ	2
4	tPHL	A		B, C _n	Σ	1
5	tPLH	A	B	C _n	C _{n+1}	1
6	tPHL	A	C _n	B	C _{n+1}	1
7	tPLH	B	A, C _n		Σ	1
8	tPHL	B	A	C _n	Σ	2
9	tPLH	B	C _n	A	Σ	2
10	tPHL	B		A, C _n	Σ	1
11	tPLH	B	A	C _n	C _{n+1}	1
12	tPHL	B	C _n	A	C _{n+1}	1
13	tPLH	C _n	A, B		Σ	1
14	tPHL	C _n	A	B	Σ	2
15	tPLH	C _n	B	A	Σ	2
16	tPHL	C _n		A, B	Σ	1
17	tPLH	C _n	A	B	Σ	2
18	tPHL	C _n	B	A	Σ	2
19	tPLH	C _n		A, B	Σ	1
20	tPHL	C _n	A	B	Σ	1
21	tPLH	C _n	B	A	C _{n+1}	1
22	tPHL	C _n	C _n	A	C _{n+1}	1
23	tPLH	C _n	A, B		Σ	1
24	tPHL	C _n	A	B	Σ	2
25	tPLH	C _n	B	A	Σ	2
26	tPHL	C _n		A, B	Σ	1
27	tPLH	C _n	A	B	Σ	1
28	tPHL	C _n	B	A	Σ	2
29	tPLH	C _n		A, B	Σ	1
30	tPHL	C _n	A	B	C _{n+1}	1
31	tPLH	C _n	B	A	C _{n+1}	1
32	tPHL	C _n		A, B	Σ	1
33	tPLH	C _n	A	B	C _{n+1}	1
34	tPHL	C _n	B	A	C _{n+1}	1
35	tPLH	C _n		A, B	Σ	1
36	tPHL	C _n	A	B	C _{n+1}	1

TTL/MSI 93190/54190, 74190 93191/54191, 74191 UP/DOWN DECADE AND BINARY COUNTER

DESCRIPTION – The 93190/54190, 74190 and 93191/54191, 74191 are Synchronous Up/Down Counters with enable control presetting facility, single line up/down control, cascading for multi-decade operation and buffered inputs. The 93190/54190, 74190 is a BCD counter, while the 93191/54191, 74191 is a 4-bit binary counter. Synchronous operation is provided by having all flip-flops clocked simultaneously so that the outputs change coincident with each other when input conditions are met. This mode of operation will eliminate the output counting spikes which are normally associated with asynchronous (ripple clock) counters.

A HIGH at the enable input inhibits counting. A LOW at the enable input and a LOW-to-HIGH clock transition triggers the four master/slave flip-flops. The enable input should be changed only when the clock is HIGH. The down/up input determines the direction of the count. When LOW, the count goes up; when HIGH, the count goes down.

These counters are fully programmable. The outputs may be preset to any state by placing a LOW on the load input and entering the desired data at the data inputs. The output will change to agree with the data inputs independently of the state of the clock input. This feature allows the counters to be used as modulo-N dividers by simply modifying the count length with the preset inputs.

Two outputs have been made available to perform the cascading function: ripple clock and maximum/minimum count. The latter output produces a HIGH level output pulse with a duration approximately equal to one complete cycle of the clock when the counter overflows or underflows. The ripple clock output produces a LOW level output pulse equal in width to the LOW level portion of the clock input when an overflow or underflow condition exists. The counters can be easily cascaded by feeding the ripple clock output to the enable input of the succeeding counter if parallel clocking is used, or to the clock input if parallel enabling is used. The maximum/minimum count output can be used to accomplish lookahead for high speed operation.

Power dissipation is typically 325 mW for either the decade or binary version. Maximum input clock frequency is typically 25 MHz and is guaranteed to be at least 20 MHz.

PIN NAMES

\bar{L}	Load Input
A, B, C, D	Parallel Input
\bar{E}	Enable Input
CP	Clock Input
DN/UP	Down/Up Input
\bar{R}/\bar{C}	Ripple Clock Output
Q_A, Q_B, Q_C, Q_D	Parallel Output
Max/Min	Max./Min. Output

LOADING

\bar{L}	1 U.L.
A, B, C, D	1 U.L.
\bar{E}	3 U.L.
CP	1 U.L.
DN/UP	1 U.L.
\bar{R}/\bar{C}	10 U.L.
Q_A, Q_B, Q_C, Q_D	10 U.L.
Max/Min	10 U.L.

1 Unit Load (U.L.) = 40 μ A HIGH/1.6 mA LOW

LOGIC SYMBOL

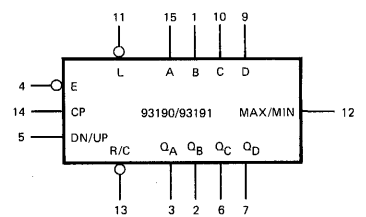

V_{CC} = Pin 16
GND = Pin 8

**93190/54190, 74190
93191/54191, 74191**

CONNECTION DIAGRAM DIP (TOP VIEW)

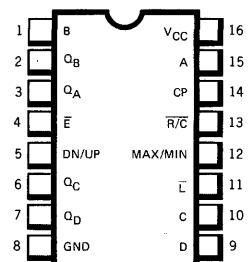

FLATPAK (TOP VIEW)

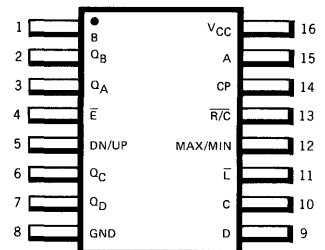

Asynchronous inputs:
LOW input to load sets $Q_A = A$,
 $Q_B = B$, $Q_C = C$, and $Q_D = D$

LOGIC DIAGRAMS

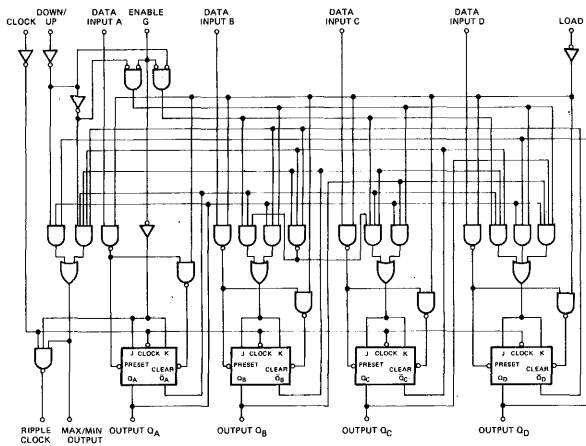

DECADE COUNTER
93190/54190, 74190

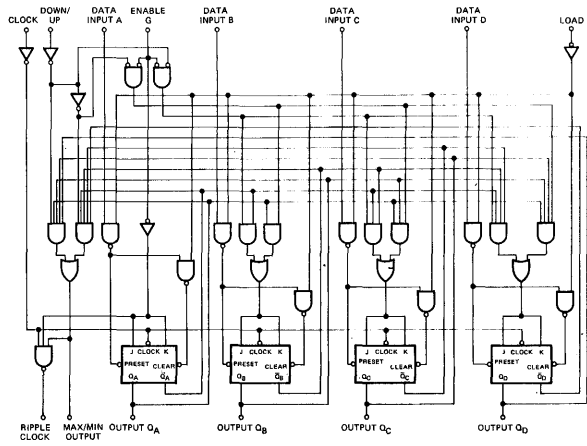

BINARY COUNTER
93191/54191, 74191

TYPICAL LOAD, COUNT, AND INHIBIT SEQUENCE

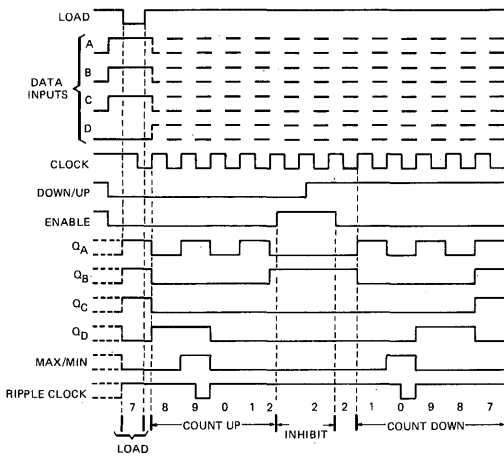

The following sequence is illustrated:

1. Load (preset) to BCD seven.
2. Count up to eight, nine (maximum), zero, one, and two.
3. Inhibit.
4. Count down to one, zero (minimum), nine, eight, and seven.

DECADE COUNTER
93190/54190, 74190

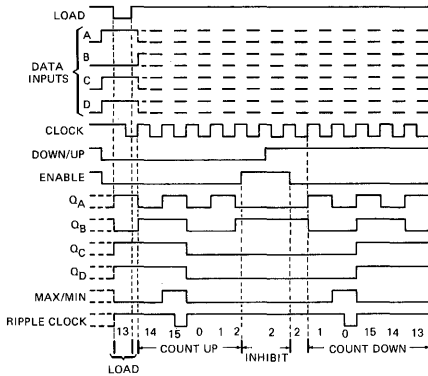

The following sequence is illustrated:

1. Load (preset) to binary thirteen.
2. Count up to fourteen, fifteen (maximum), zero, one, and two.
3. Inhibit.
4. Count down to one, zero (minimum), fifteen, fourteen, and thirteen.

BINARY COUNTER
93191/54191, 74191

TTL/MSI • 93190/54190, 74190 • 93191/54191, 74191

ABSOLUTE MAXIMUM RATINGS (above which the useful life may be impaired)

Storage Temperature	-65°C to +150°C
Temperature (Ambient) Under Bias	-55°C to +125°C
V _{CC} Pin Potential to Ground Pin	-0.5 V to +7.0 V
*Input Voltage (dc)	-0.5 V to +5.5 V
*Input Current (dc)	-30 mA to +5.0 mA
Voltage Applied to Outputs (Output HIGH)	-0.5 V to +V _{CC} value
Output Current (dc) (Output LOW)	+30 mA

*Either Input Voltage limit or Input Current limit is sufficient to protect the inputs.

RECOMMENDED OPERATING CONDITIONS

PARAMETER	93190XM/54190XM 93191XM/54191XM			93190XC/74190XC 93191XC/74191XC			UNITS
	MIN.	TYP.	MAX.	MIN.	TYP.	MAX.	
Supply Voltage V _{CC}	4.5	5.0	5.5	4.75	5.0	5.25	Volts
Operating Free Air Temperature Range	-55	25	125	0	25	70	°C
Normalized Fan Out from Each Output, N	HIGH Level		20			20	U.L.
	LOW Level		10			10	
Input Clock Frequency, f _{clock}	0		20	0		20	MHz
Width of Clock Input Pulse, t _{w(clock)}	25			25			ns
Width of Load Input Pulse, t _{w(load)}	35			35			ns
Data Setup Time, t _{setup} (See Fig. 1 and 2)	20			20			ns
Data Hold Time, t _{hold}	0			0			ns

X = package type; F for Flatpak, D for Ceramic Dip, P for Plastic Dip. See Packaging Information Section for packages available on this product.

ELECTRICAL CHARACTERISTICS OVER OPERATING TEMPERATURE RANGE (Unless Otherwise Noted)

SYMBOL	PARAMETER	LIMITS			UNITS	TEST CONDITIONS (Note 1)
		MIN.	TYP. (Note 2)	MAX.		
V _{IH}	Input HIGH Voltage	2.0			Volts	Guaranteed Input HIGH Threshold Voltage
V _{IL}	Input LOW Voltage			0.8	Volts	Guaranteed Input LOW Threshold Voltage
V _{CD}	Input Clamp Diode Voltage			-1.5	Volts	V _{CC} = MIN., I _{IN} = -12mA
V _{OH}	Output HIGH Voltage	2.4			Volts	V _{CC} = MIN., I _{OH} = -800 μA, V _{IH} = 2.0 V, V _{IL} = 0.8 V
V _{OL}	Output LOW Voltage			0.4	Volts	V _{CC} = MIN., I _{OL} = 16 mA, V _{IH} = 2.0 V, V _{IL} = 0.8 V
I _I	Input Current at Max Input Voltage			1.0	mA	V _{CC} = MAX., V _{IN} = 5.5 V
I _{IH}	Input HIGH Current	Other Inputs		40	μA	V _{CC} = MAX., V _{IN} = 2.4 V
		Enable Input		120		
I _{IL}	Input LOW Current	Other Inputs		-1.6	mA	V _{CC} = MAX., V _{IN} = 0.4 V
		Enable Input		-4.8		
I _{OS}	Output Short Circuit Current (Note 3)	-20		-65	mA	93190/54190; 93191/54191 93190/74190; 93191/74191
		-18		-65		
I _{CC}	Supply Current (Note 4)		65	105	mA	V _{CC} = MAX.

NOTES:

- (1) For conditions shown as MIN. or MAX., use the appropriate value specified under recommended operating conditions for the applicable device type.
- (2) Typical limits are at V_{CC} = 5.0 V, 25°C.
- (3) Not more than one output should be shorted at a time.
- (4) I_{CC} is measured with all inputs grounded and all outputs open.

SWITCHING CHARACTERISTICS (T_A = 25°C)

SYMBOL	PARAMETER	LIMITS			UNITS	A TEST CONDITIONS
		MIN.	TYP.	MAX.		
f _{max}	Max. Input Clock Frequency	20	25		MHz	V _{CC} = 5.0 V C _L = 15 pF R _L = 400Ω (See Fig. 1 and Fig. 3 thru 7)
t _{PLH}	Load Input to		22	33	ns	
t _{PHL}	Q _A , Q _B , Q _C , Q _D Output		33	50		
t _{PLH}	Data Input A, B, C, D, to		14	22	ns	
t _{PHL}	Q _A , Q _B , Q _C , Q _D Output		35	50		
t _{PLH}	Clock Input to Ripple		13	20	ns	
t _{PHL}	Clock Output		16	24		
t _{PLH}	Clock Input to		16	24	ns	
t _{PHL}	Q _A , Q _B , Q _C , Q _D Output		24	36		
t _{PLH}	Clock Input to		28	42	ns	
t _{PHL}	Max./Min. Output		37	52		
t _{PLH}	Down/Up Input to		30	45	ns	
t _{PHL}	Ripple Clock Output		30	45		
t _{PLH}	Down/Up Input to		21	33	ns	
t _{PHL}	Max./Min. Output		22	33		

PARAMETER MEASUREMENT INFORMATION

SWITCHING CHARACTERISTICS

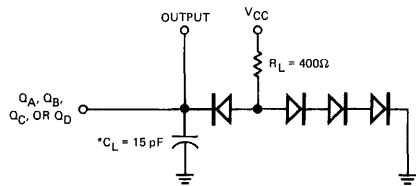

*C_L includes probe & jig capacitance.

Fig. 1 – LOAD CIRCUIT FOR SWITCHING TIME MEASUREMENT

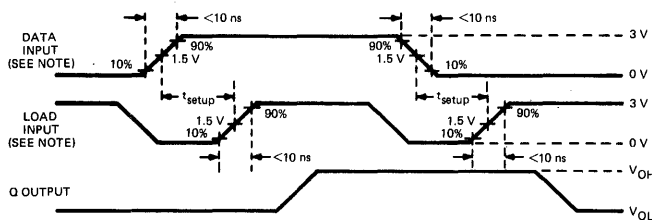
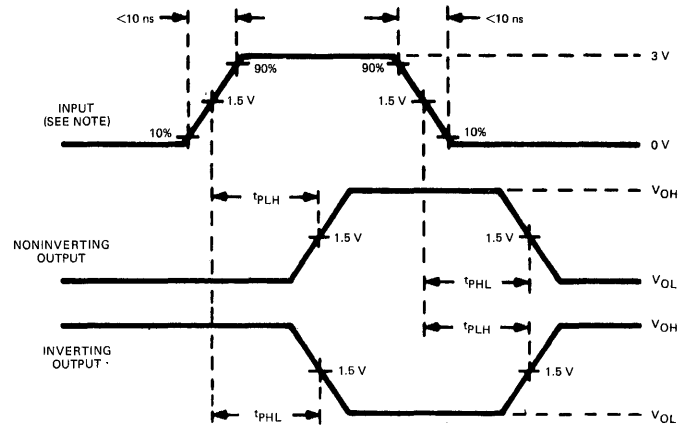

Fig. 2 – SETUP TIME VOLTAGE WAVEFORMS

NOTE:

The input pulses are supplied by generators having the following characteristics: Z_{out} = 50Ω, duty cycle ≤ 50%, PRR ≤ 1 MHz.



See waveform sequences in Figures 4 through 7 for propagation times from a specific input to a specific output. For simplification, pulse rise times, reference levels, etc., have not been shown in Figures 4 through 7.

Fig. 3 – GENERAL VOLTAGE WAVEFORMS FOR PROPAGATION TIMES

PARAMETER MEASUREMENT INFORMATION

SWITCHING CHARACTERISTICS (cont'd)

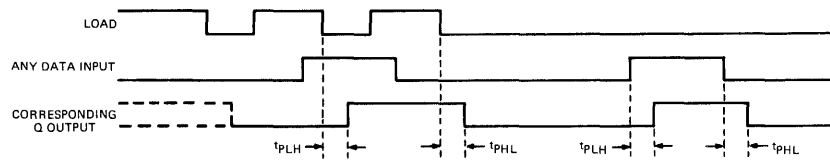

NOTE: Conditions on other inputs are irrelevant.

Fig. 4 – LOAD TO OUTPUT AND DATA TO OUTPUT

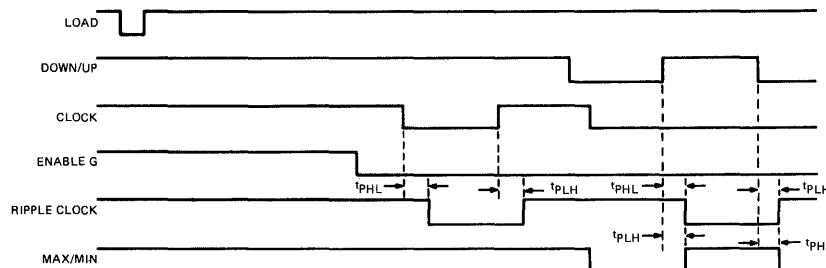

NOTE: All data inputs are LOW.

Fig. 5 – ENABLE TO RIPPLE CLOCK, CLOCK TO RIPPLE CLOCK, DOWN/UP TO RIPPLE CLOCK, AND DOWN/UP TO MAX/MIN

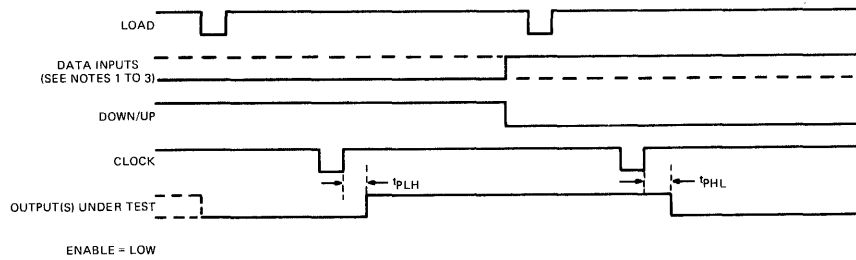

ENABLE = LOW

NOTES:

1. To test Q_A , Q_B , and Q_C outputs of 93190/54190: Data inputs A, B, and C are shown by the solid line. Data input D is shown by the dashed line.
2. To test Q_D output of 93190/54190: Data inputs A and D are shown by the solid line. Data inputs B and C are held at the LOW logic level.
3. To test Q_A , Q_B , Q_C , and Q_D outputs of 93191/54191: All four data inputs are shown by the solid line.

Fig. 6 – CLOCK TO OUTPUT

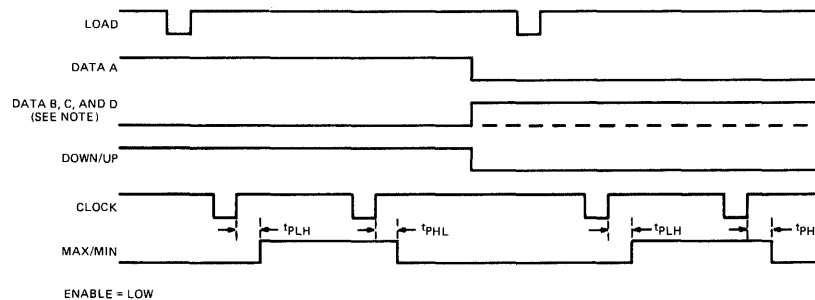

ENABLE = LOW

NOTE: Data inputs B and C are shown by the dashed line for 93190/54190 and the solid line for 93191/54191. Data input D is shown by the solid line for both devices.

Fig. 7 – CLOCK TO MAX/MIN

TTL/MSI 93196/54196, 74196 93197/54197, 74197

HIGH SPEED DECADE AND BINARY COUNTER

TO BE ANNOUNCED

DESCRIPTION – The 93196/54196, 74196 and 93197/54197, 74197 High Speed Counters will provide either a divide-by-two and a divide-by-five counter (93196/54196, 74196) or a divide-by-two and a divide-by-eight counter (93197/54197, 74197). The counters are fully presettable to any output state by placing a LOW on the count/load input and entering the desired data at the data inputs. The outputs will change to agree with the data inputs regardless of the state of the clocks.

These counters may also be used as 4-bit latches by using the count/load input as the strobe and entering data at the data inputs. The outputs will directly follow the data inputs when the count/load is LOW, but will remain unchanged when the count/load is HIGH and the clock inputs are inactive.

These high speed counters will accept count frequencies of 0 to 50 MHz at the clock 1 input and 0 to 25 MHz at the clock 2 input. During the count operation, transfer of information to the outputs occurs on the negative-going edge of the clock pulse. These counters feature a direct clear which, when taken LOW, sets all outputs LOW regardless of the states of the clocks.

All inputs are diode-clamped to minimize transmission-line effects and simplify system design. Typical power dissipation is 240 mW.

PIN NAMES

P_A, P_B, P_C, P_D
 CP_1, CP_2
CLEAR
COUNT/LOAD
 Q_A, Q_B, Q_C, Q_D

Parallel Inputs
Clock Inputs (Note b)
Clear Input
Count Load Input
Parallel Outputs

LOADING
(Note a)

1 U.L.
2 U.L.
2 U.L.
1 U.L.
10 U.L.

NOTES:

- (a) 1 U.L. = 40 μ A HIGH/1.6 mA LOW
- (b) CP_2 – 3 U.L. on 93196

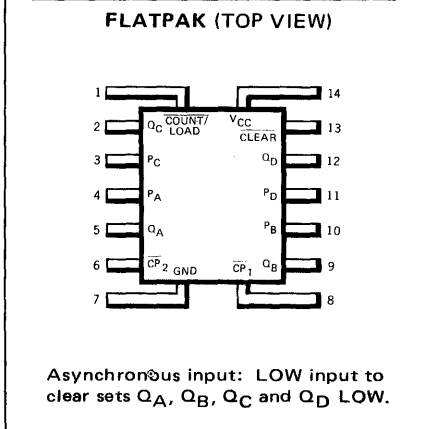
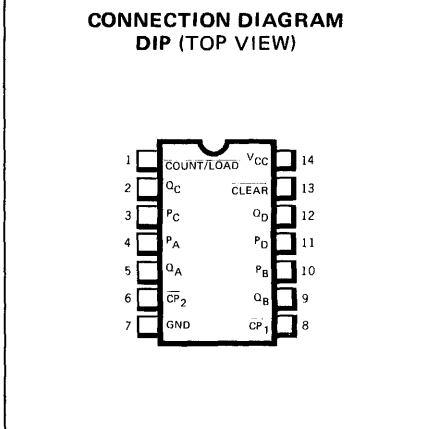
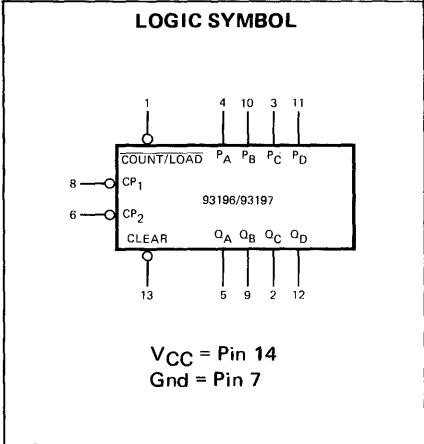
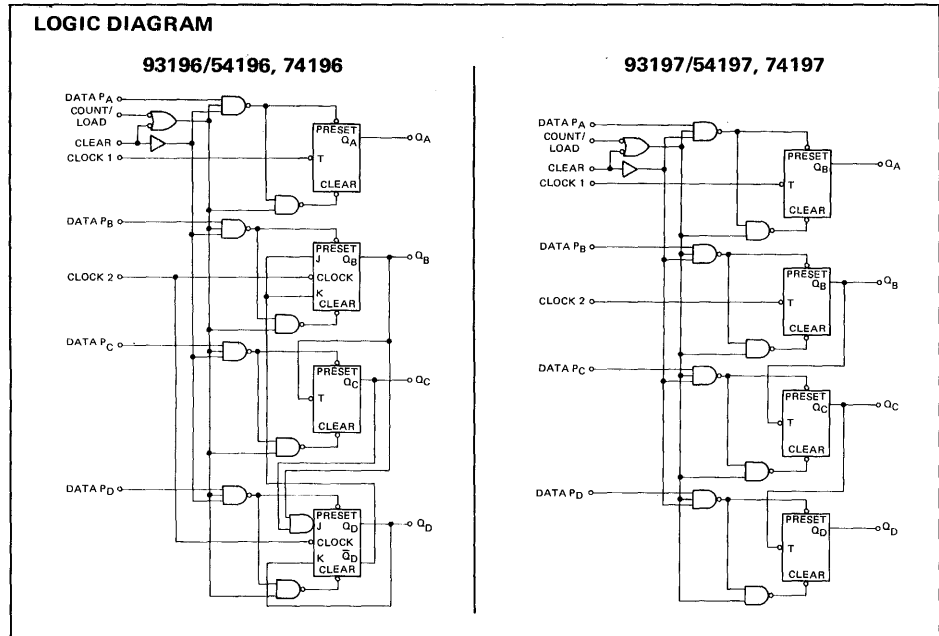

HIGH SPEED TTL/MSI • 93196/54196, 74196 • 93197/54197, 74197

RECOMMENDED OPERATING CONDITIONS

PARAMETER	93196XM/54196XM 93197XM/54197XM			93196XC/74196XC 93197XC/74197XC			UNITS
	MIN.	TYP.	MAX.	MIN.	TYP.	MAX.	
Supply Voltage V_{CC}	4.5	5.0	5.5	4.75	5.0	5.25	Volts
Operating Free-Air Temperature Range	-55	25	125	0	25	70	°C
Normalized Fan Out from Each Output, N HIGH Logic/LOW Logic			20/10			20/10	U.L.
Count Frequency (See Fig. 1) $\overline{CP}_1/\overline{CP}_2$	0/0		50/25	0/0		50/25	MHz
Pulse Width, t_w (See Fig. 1)	$\overline{CP}_1/\overline{CP}_2$	10/20		10/20			ns
	Clear/Load	15/20		15/20			
Input Hold Time, t_{hold} HIGH & LOW (See Fig. 1) Level Data		t_w (Load)		t_w (Load)			ns
Input Setup Time, t_{setup} (See Fig. 1) HIGH Data/LOW Data		10/15		10/15			ns
Count Enable Time, t_{enable} * (See Fig. 1)		20		20			ns
Clock Input Pulse Fall Time t_f (See Fig. 1)			75			75	ns

X = package type; F for Flatpak, D for Ceramic Dip, P for Plastic Dip. See Packaging Information Section for packages available on this product.

*Count enable time is the interval immediately preceding the negative-going edge of the clock pulse during which interval the count/load and clear inputs must be both HIGH to ensure counting.

ELECTRICAL CHARACTERISTICS OVER OPERATING TEMPERATURE RANGE (Unless Otherwise Noted)

SYMBOL	PARAMETER	LIMITS			UNITS	TEST CONDITIONS (Note 1)	
		MIN.	TYP. (Note 2)	MAX.			
V_{IH}	Input HIGH Voltage	2.0			Volts	Guaranteed Input HIGH Voltage	
V_{IL}	Input LOW Voltage			0.8	Volts	Guaranteed Input LOW Voltage	
V_{CD}	Input Clamp Diode Voltage			-1.5	Volts	$V_{CC} = \text{MAX.}$, $I_{IN} = -12 \text{ mA}$	
V_{OH}	Output HIGH Voltage	2.4			Volts	$V_{CC} = \text{MIN.}$, $I_{OH} = -800 \mu\text{A}$, $V_{IH} = 2.0 \text{ V}$, $V_{IL} = 0.8 \text{ V}$	
V_{OL}	Output LOW Voltage			0.4	Volts	$V_{CC} = \text{MIN.}$, $I_{OL} = 16 \text{ mA}$, (Note 4) $V_{IH} = 2.0 \text{ V}$, $V_{IL} = 0.8 \text{ V}$	
I_I	Input Current at Max. Input Voltage			1.0	mA	$V_{CC} = \text{MAX.}$, $V_{IN} = 5.5 \text{ V}$	
I_{IH}	Input HIGH Current	Data, Count/Load		40	μA	$V_{CC} = \text{MAX.}$ $V_{IN} = 2.4 \text{ V}$	
		Clear, \overline{CP}_1		80	μA		
		\overline{CP}_2		120	μA		
		80	μA	93196/54196, 74196			
				93197/54197, 74197			
I_{IL}	Input LOW Current	Data, Count/Load		-1.6	mA	$V_{CC} = \text{MAX.}$ $V_{IN} = 0.4 \text{ V}$	
		Clear		-3.2	mA		
		\overline{CP}_1		-4.8	mA		
				-6.4	mA		93196/54196, 74196
				-3.2	mA		93197/54197, 74197
I_{OS}	Output Short Circuit Current (Note 3)		-20	-57	mA	93196/54196, 93197/54197	
			-18	-57	mA	93196/74196, 93197/74197	
I_{CC}	Supply Current (Note 5)		48	59	mA	$V_{CC} = \text{MAX.}$	

NOTES:

- (1) For conditions shown as MIN. or MAX., use the appropriate value specified under recommended operating conditions for the applicable device type.
- (2) Typical limits are at $V_{CC} = 5.0\text{V}$, 25°C .
- (3) Not more than one output should be shorted at a time.
- (4) Q_A outputs are tested at $I_{OL} = 16 \text{ mA}$ plus the limit value of I_{IL} for the clock 2 input. This permits driving the clock 2 input while fanning out to 10 Series 54/74 loads.
- (5) I_{CC} is measured with all inputs grounded and all outputs open.

TYPICAL COUNT CONFIGURATIONS

93196/54196, 74196

The output of flip-flop A is not internally connected to the succeeding flip-flops; therefore, the count may be operated in three independent modes:

1. When used as a BCD decade counter, the clock 2 input must be externally connected to the Q_A output. The clock 1 input receives the incoming count, and a count sequence is obtained in accordance with the BCD count sequence truth table shown at the right.
2. If a symmetrical divide-by-ten count is desired for any application requiring division of a binary count by a power of ten, the Q_D output must be externally connected to the clock 1 input. The input count is then applied at the clock 2 input and a divide-by-ten square wave is obtained at output Q_A in accordance with the bi-quinary truth table shown at the right.
3. For operation as a divide-by-two counter and a divide-by-five counter, no external interconnections are required. Flip-flop A is used as a binary element for the divide-by-two function. The clock 2 input is used to obtain binary divide-by-five operation at the Q_B, Q_C, and Q_D outputs. In this mode, the two counters operate independently; however, all four flip-flops are loaded and cleared simultaneously.

DECADE (BCD)
(See Note A)

COUNT	OUTPUT			
	Q _D	Q _C	Q _B	Q _A
0	L	L	L	L
1	L	L	L	H
2	L	L	H	L
3	L	L	H	H
4	L	H	L	L
5	L	H	L	H
6	L	H	H	L
7	L	H	H	H
8	H	L	L	L
9	H	L	L	H

- NOTES:
A. Output Q_A connected to clock 2 input.
B. Output Q_D connected to clock 1 input.

93196/54196, 74196
TRUTH TABLES

BI-QUINARY (5-2)
(See Note B)

COUNT	OUTPUT			
	Q _A	Q _D	Q _C	Q _B
0	L	L	L	L
1	L	L	L	H
2	L	L	H	L
3	L	L	H	H
4	L	H	L	L
5	H	L	L	L
6	H	L	L	H
7	H	L	H	L
8	H	L	H	H
9	H	H	L	L

93197/54197, 74197

The output of flip-flop A is not internally connected to the succeeding flip-flops, therefore the counter may be operated in two independent modes:

1. When used as a high speed 4-bit ripple counter, output Q_A must be externally connected to the clock 2 input. The input count pulses are applied to the clock 1 input. Simultaneous divisions by 2, 4, 8 and 16 are performed at the Q_A, Q_B, Q_C, Q_D output as shown in the truth table at the right.
2. When used as a 3-bit ripple counter, the input count pulses are applied to the clock 2 input. Simultaneous frequency divisions by 2, 4 and 8 are available at the Q_B, Q_C, and Q_D outputs. Independent use of flip-flop A is available if the load and clear functions coincide with those of the 3-bit ripple counter.

93197/54197, 74197
TRUTH TABLE
(See Note A)

COUNT	OUTPUT			
	Q _D	Q _C	Q _B	Q _A
0	L	L	L	L
1	L	L	L	H
2	L	L	H	L
3	L	L	H	H
4	L	H	L	L
5	L	H	L	H
6	L	H	H	L
7	L	H	H	H
8	H	L	L	L
9	H	L	L	H
10	H	L	H	L
11	H	L	H	H
12	H	H	L	L
13	H	H	L	H
14	H	H	H	L
15	H	H	H	H

- NOTE:
A. Output Q_A connected to clock 2 input.

ABSOLUTE MAXIMUM RATINGS (above which the useful life may be impaired)

Storage Temperature	-65°C to +150°C
Temperature (Ambient) Under Bias	-55°C to +125°C
V _{CC} Pin Potential to Ground Pin	-0.5 V to +7.0 V
*Input Voltage (dc)	-0.5 V to +5.5 V
*Input Current (dc)	-30 mA to +5.0 mA
Voltage Applied to Outputs (Output HIGH)	-0.5 V to +V _{CC} value
Output Current (dc) (Output LOW)	+30 mA

*Either Input Voltage limit or Input Current limit is sufficient to protect the inputs.

SWITCHING CHARACTERISTICS ($T_A = 25^\circ\text{C}$) (see Fig. 1)

SYM-BOL	PARAMETER	LIMITS			UNITS	TEST CONDITIONS
		MIN.	TYP.	MAX.		
f_{MAX}	(MAX. Input Count Frequency)	50	70		MHz	$V_{\text{CC}} = 5\text{ V}$ $R_L = 400\ \Omega$ $C_L = 15\ \text{pF}$
t_{PLH} t_{PHL}	Clock 1 Input to Q_A Output		7.0 10	12 15	ns	
t_{PLH} t_{PHL}	Clock 2 Input to Q_B Output		12 14	18 21	ns	
t_{PLH} t_{PHL}	Clock 2 Input to Q_C Output		24 28	36 42	ns	
t_{PLH} t_{PHL}	Clock 2 Input to Q_D Output		14 36	21 54	ns	
t_{PLH} t_{PHL}	Clock 2 Input to Q_D Output		12 42	18 63	ns	
t_{PLH} t_{PHL}	A, B, C, D Inputs to Q_A, Q_B, Q_C, Q_D Outputs		16 25	24 38	ns	
t_{PLH} t_{PHL}	Load Input to Any Output		22 24	33 36	ns	
t_{PHL}	Clear Input to Any Output		25	37	ns	

PARAMETER MEASUREMENT INFORMATION

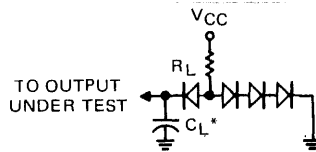

* C_L includes probe and jig capacitance.

LOAD CIRCUIT

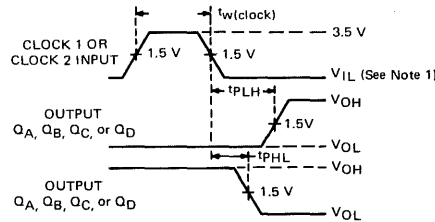

CLOCK-MODE VOLTAGE WAVEFORMS

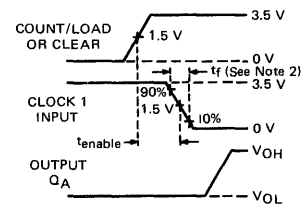

CLOCK ENABLE TIME VOLTAGE WAVEFORMS

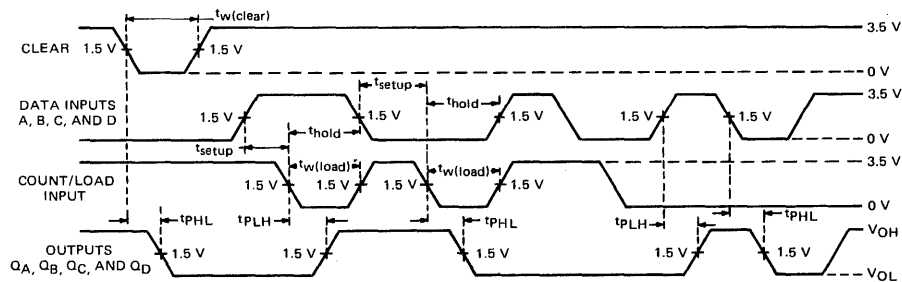

CLEAR AND LOAD VOLTAGE WAVEFORMS

- NOTES:
1. The input pulse generator has the following characteristics: for testing f_{max} , $V_{\text{IL}} = 0.3 \pm 0.1\text{ V}$, duty cycle = 50%, $t_r < 5\text{ ns}$, and $t_f < 5\text{ ns}$; for all other measurements $V_{\text{IL}} = 0$, PRR $\leq 1\text{ MHz}$, duty cycle $\leq 50\%$, $t_r < 5\text{ ns}$, and unless otherwise specified, $t_f < 5\text{ ns}$.
 2. Fall time of clock 1 is measured with count/load and clear high. When measuring clock enable time, $t_f < 5\text{ ns}$.
 3. Unless otherwise specified, Q_A is connected to Clock 2.

Fig. 1

TTL/MSI 93198/54198, 74198

8-BIT SHIFT REGISTER

TO BE ANNOUNCED

DESCRIPTION — The 93198/54198, 74198 are Bidirectional Registers that are designed to incorporate virtually all of the features a system designer may want in a shift register. The 93198/54198, 74198 feature 35 MHz shift frequency, parallel inputs, parallel outputs, right-shift and left-shift serial inputs, operating mode-control inputs and a direct overriding clear line. The register has four distinct modes of operation: (1) parallel (broadside) load, (2) shift right (in the direction Q_A toward Q_H), (3) shift left (in the direction Q_H toward Q_A), (4) inhibit clock (do nothing).

Synchronous parallel loading is accomplished by applying the eight bits of data and taking both mode control inputs, S_0 and S_1 , HIGH. The data is loaded into the associated flip-flop and appears at the outputs after the positive transition of the clock input. During loading, serial data flow is inhibited.

Shift right is accomplished synchronously with the rising edge of the clock pulse when S_0 is HIGH and S_1 is LOW. Serial data for this mode is entered at the shift-right data input. When S_0 is LOW and S_1 is HIGH, data shifts left synchronously and new data is entered at the shift-left serial input.

Clocking of the flip-flop is inhibited when both mode control inputs are LOW. The mode controls should be changed only while the clock input is HIGH.

Typical power dissipation is 360 mW and all inputs are diode-clamped.

PIN NAMES

PIN NAME	FUNCTION	LOADING
P_A to P_H	Parallel Data Inputs	1 U.L.
S_0, S_1	Mode Control Inputs	1 U.L.
L	Shift Left Serial Input	1 U.L.
R	Shift Right Serial Input	1 U.L.
CP	Clock (Active HIGH Going Edge) Input	1 U.L.
CL	Clear (Active LOW) Input	1 U.L.
Q_A to Q_H	Data Outputs	10 U.L.

1 Unit Load (U.L.) = 40 μ A HIGH/1.6 mA LOW

TRUTH TABLE

OPERATION OF MODE CONTROL

INPUTS		MODE
S_1	S_0	
L	L	INHIBIT CLOCK
L	H	SHIFT RIGHT
H	L	SHIFT LEFT
H	H	PARALLEL LOAD

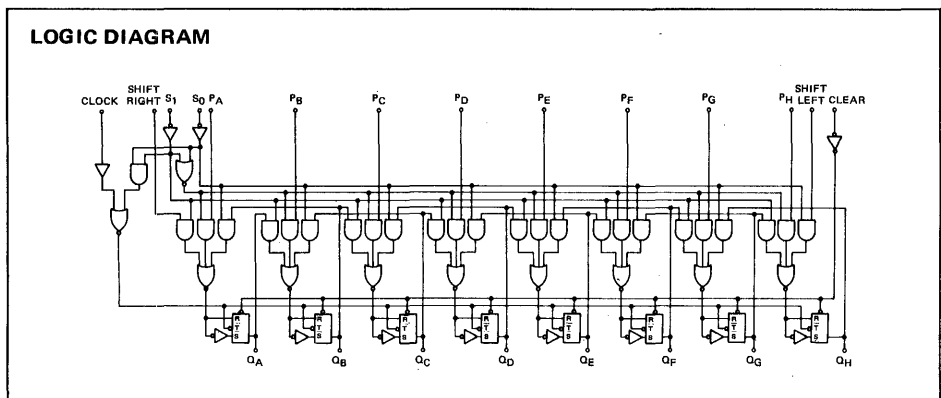
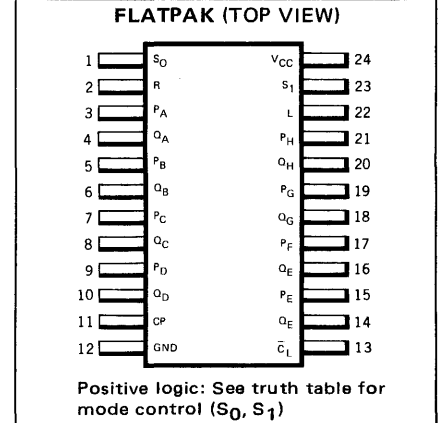
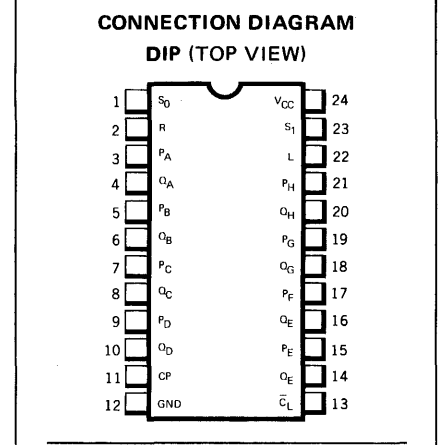
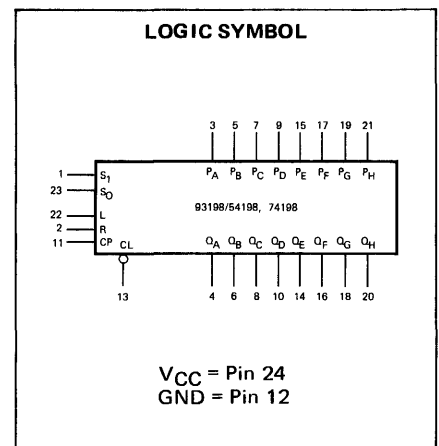

ABSOLUTE MAXIMUM RATINGS (above which the useful life may be impaired)

Storage Temperature	-65°C to +150°C
Temperature (Ambient) Under Bias	-55°C to +125°C
V _{CC} Pin Potential to Ground Pin	-0.5 V to +7.0 V
*Input Voltage (dc)	-0.5 V to +5.5 V
*Input Current (dc)	-30 mA to +5.0 mA
Voltage Applied to Outputs (Output HIGH)	-0.5 V to +V _{CC} value
Output Current (dc) (Output LOW)	+30 mA

* Either Input Voltage limit or Input Current limit is sufficient to protect the inputs.

RECOMMENDED OPERATING CONDITIONS

PARAMETER	93198XM/54198XM			93198XC/74198XC			UNITS
	MIN.	TYP.	MAX.	MIN.	TYP.	MAX.	
Supply Voltage V _{CC}	4.5	5.0	5.5	4.75	5.0	5.25	Volts
Operating Free-Air Temperature Range	-55	25	125	0	25	70	°C
Normalized Fan Out from Each Output, N	HIGH Level		20			20	U.L.
	LOW Level		10			10	
Input Count Frequency, f _{count}	0		25	0		25	MHz
Width of Clock or Clear Pulse, t _w (See Fig. 1)	20			20			ns
Mode-Control Setup Time, t _{setup}	30			30			ns
Data Setup Time, t _{setup} (See Fig. 1)	20			20			ns
Hold Time at Any Input, t _{hold} (See Fig. 1)	0			0			ns

X = package type; F for Flatpak, D for Ceramic Dip, P for Plastic Dip. See Packaging Information Section for packages available on this product.

ELECTRICAL CHARACTERISTICS OVER OPERATING TEMPERATURE RANGE (Unless Otherwise Noted)

SYMBOL	PARAMETER	LIMITS			UNITS	TEST CONDITIONS (Note 1)	
		MIN.	TYP. (Note 2)	MAX.			
V _{IH}	Input HIGH Voltage	2.0			Volts	Guaranteed Input HIGH Voltage	
V _{IL}	Input LOW Voltage			0.8	Volts	Guaranteed Input LOW Voltage	
V _{CD}	Input Clamp Diode Voltage			-1.5	Volts	V _{CC} = MAX., I _{IN} = -12 mA	
V _{OH}	Output HIGH Voltage	2.4			Volts	V _{CC} = MIN., I _{OH} = -800 μA, V _{IH} = 2.0 V, V _{IL} = 0.8 V	
V _{OL}	Output LOW Voltage			0.4	Volts	V _{CC} = MIN., I _{OL} = 16 mA, V _{IH} = 2.0 V, V _{IL} = 0.8 V	
I _I	Input Current at MAX. Input Voltage			1.0	mA	V _{CC} = MAX., V _{IN} = 5.5 V	
I _{IH}	Input HIGH Current			40	μA	V _{CC} = MAX., V _{IN} = 2.4 V	
I _{IL}	Input LOW Current			-1.6	mA	V _{CC} = MAX., V _{IN} = 0.4 V	
I _{OS}	Output Short Circuit Current (Note 3)	-20		-57	mA	93198/54198	V _{CC} = MAX.
		-18		-57	mA	93198/74198	
I _{CC}	Supply Current		72	104	mA	93198/54198	V _{CC} = MAX., S ₀ , S ₁ = 4.5 V CP = Momentary GND then 4.5 V CL, P _A to P _H = GND All Outputs are Open
			72	116	mA	93198/74198	

SWITCHING CHARACTERISTICS (T_A = 25°C)

SYMBOL	PARAMETER	LIMITS			UNITS	TEST CONDITIONS
		MIN.	TYP.	MAX.		
f _{MAX}	Maximum Input Count Frequency	25	35		MHz	V _{CC} = 5.0 V C _L = 15 pF R _L = 400 Ω (see Fig. 1)
t _{PHL}	Turn On Delay Clear to Output		23	35	ns	
t _{PLH}	Turn Off Delay Clock to Output	8	17	26	ns	
t _{PHL}	Turn On Delay Clock to Output	8	20	30	ns	

NOTES:

- (1) For conditions shown as MIN. or MAX., use the appropriate value specified under recommended operating conditions for the applicable device type.
- (2) Typical limits are at V_{CC} = 5.0 V, 25°C.
- (3) Not more than one output should be shorted at a time.

TYPICAL CLEAR, LOAD, RIGHT-SHIFT, LEFT-SHIFT, INHIBIT, AND CLEAR SEQUENCES

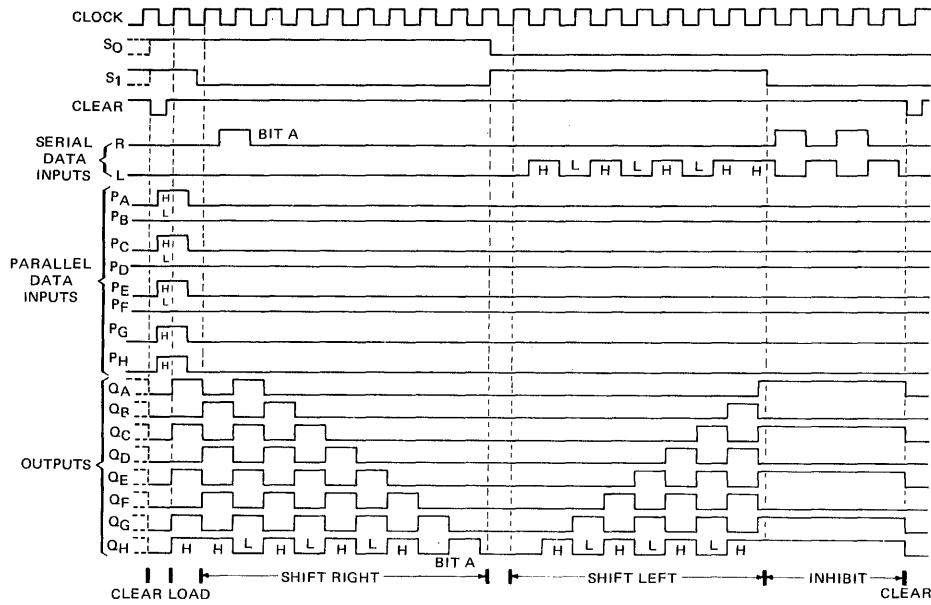

SWITCHING PARAMETER MEASUREMENT INFORMATION

LOAD FOR OUTPUT UNDER TEST

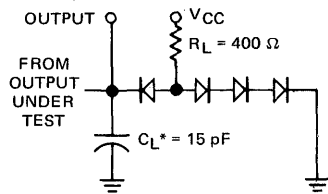

* C_L includes probe and jig capacitance.

TEST TABLE FOR SYNCHRONOUS INPUTS

DATA INPUT FOR TEST	S_1	S_0	OUTPUT TESTED (SEE NOTE 3)
PA	4.5 V	4.5 V	Q_A at t_n+1
PB	4.5 V	4.5 V	Q_B at t_n+1
PC	4.5 V	4.5 V	Q_C at t_n+1
PD	4.5 V	4.5 V	Q_D at t_n+1
PE	4.5 V	4.5 V	Q_E at t_n+1
PF	4.5 V	4.5 V	Q_F at t_n+1
PG	4.5 V	4.5 V	Q_G at t_n+1
PH	4.5 V	4.5 V	Q_H at t_n+1
L Serial Input	4.5 V	0 V	Q_A at t_n+8
R Serial Input	0 V	4.5 V	Q_H at t_n+8

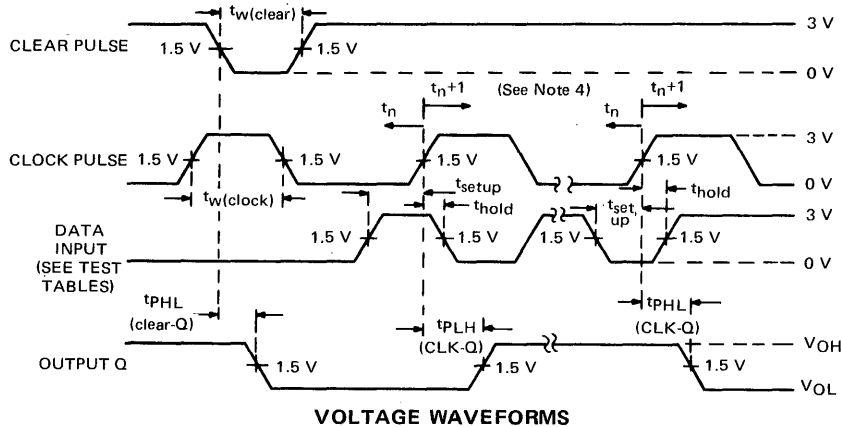

NOTES:

- The clock pulse has the following characteristics: $t_w(\text{clock}) \geq 20 \text{ ns}$ and $\text{PRR} = 1 \text{ MHz}$. The clear pulse has the following characteristics: $t_w(\text{clear}) \geq 20 \text{ ns}$ and $t_{\text{hold}} = 0 \text{ ns}$. When testing f_{MAX} , vary the clock PRR.
- A clear pulse is applied prior to each test.
- Propagation delay times (t_{PLH} and t_{PHL}) are measured at t_n+1 . Proper shifting of data is verified at t_n+8 with a functional test.
- t_n = bit time before clocking transition
 t_n+1 = bit time after one clocking transition
 t_n+8 = bit time after eight clocking transitions

Fig. 1

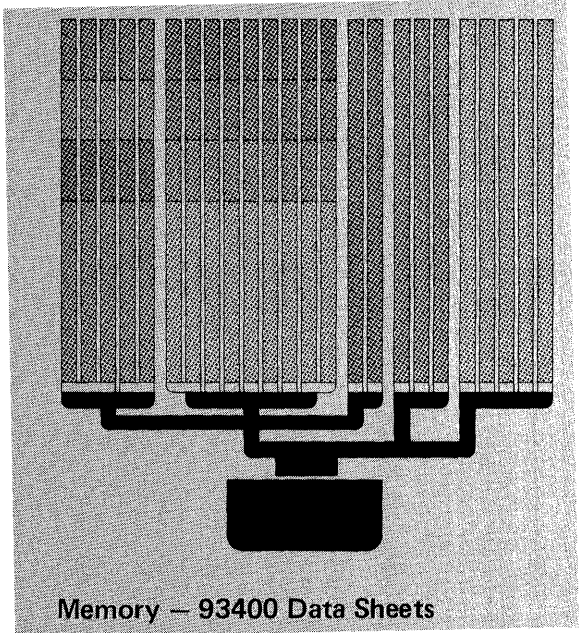

Memory – 9340 Data Sheets

TTL MEMORY 93400 • 93400B • 93401

256-BIT READ/WRITE MEMORY & DECODER/DRIVER

FORMERLY 4100 • 4100B • 4101

DESCRIPTION — The 93400 256-Bit Read/Write Memory and the 93401 Decoder/Driver are components for use in high speed memory systems. The 93400 is a fast 256 x 1 random access read/write memory which is addressed with a partially decoded x-y coincident selection scheme. There are two device grades, with the 93400B having a slower access time than the 93400. The companion decoder and buffer driver, 93401, converts binary addresses into the partially decoded form required by the 93400, and provides sufficient drive to connect to 32 93400's. Both devices are supplied in 16-lead Dual In-Line Packages.

93400/93400B

- TTL COMPATIBLE
- 16-LEAD PACKAGE
- OUTPUT WIRED-OR CAPABILITY
- 70 ns TYPICAL ACCESS TIME (93400)
- 125 ns TYPICAL ACCESS TIME (93400B)
- LOW INPUT LOADING

93401

- TTL COMPATIBLE
- 16-LEAD PACKAGE
- 20 ns TYPICAL THROUGH DELAY
- LOW INPUT LOADING
- 4 ENABLE INPUTS FOR CHIP SELECTION
- DRIVES UP TO 32 93400's

ABSOLUTE MAXIMUM RATINGS

V _{CC} Pin Potential to Ground Pin	-0.5 V to +7.0 V
Input Voltage	-0.5 V to +5.25 V
Voltage Applied to Output when Output is HIGH	-0.5 V to +V _{CC}
Current into Output when Output is LOW	+25 mA
Storage Temperature	-65°C to +150°C

LOGIC DIAGRAM

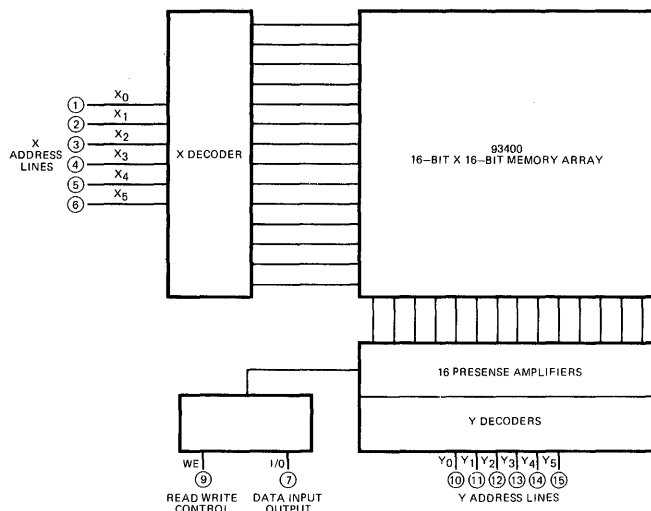

○ = PIN NUMBERS

LOGIC SYMBOLS

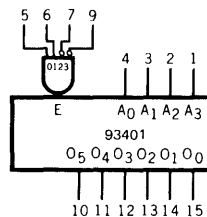
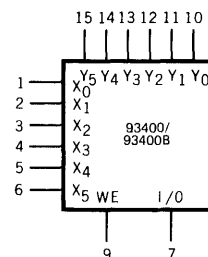

V_{CC} = Pin 16
Gnd = Pin 8

CONNECTION DIAGRAMS (TOP VIEWS)

93400/93400B

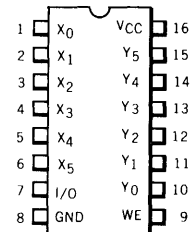

93401

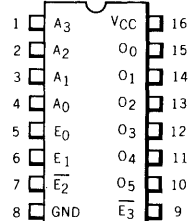

FAIRCHILD TTL MEMORY 93400 • 93400B • 93401

FUNCTIONAL DESCRIPTIONS

The 93400 and 93400B contain 256 bipolar storage cells arranged in a 16 by 16 format. Any one of the 256 cells may be accessed by supplying an address code on the X address inputs and the Y address inputs. Internal decoders decode the X and Y addresses into one of 16 rows and one of 16 columns in the matrix of storage cells. Data may be written into or read out from the cell lying at the intersection of the selected row and column.

The X and Y addresses supplied to the 93400 and 93400B are partially decoded in a "3 of 6" code. Of the six X address lines and the six Y address lines there are always three lines HIGH and three lines LOW. There are 20 such combinations, 16 are decoded by the internal row and column decoders. The four unused combinations of 3 of 6 will not select any row or column. If there are more than three lines HIGH in either the X or Y address, then multiple row or column selection will occur. The sixteen 3 of 6 codes used by the 93400 and 93400B are generated by the 93401 decoder/driver.

Data enters and leaves the memory on a single input/output (I/O) line (pin 7). The I/O line is an open collector output, so many 93400 I/O lines can be connected together in a wired-OR configuration. Input data must be applied to the I/O lines through an open collector gate. Each I/O line requires a pull-up resistor to V_{CC}. The magnitude of the pull-up resistor is determined by the number of 93400 I/O lines tied together. The I/O of a 93400 which is not addressed will be HIGH.

Read/Write selection is determined by the state of pin 9, the active HIGH write enable. When WE is HIGH, the data on the I/O line will be written into the selected address in the 93400. When the Write Enable line is LOW, data will be read out of the addressed location.

The 93401 is a partial decoder and driver for the 93400. It accepts a 4-bit binary code on the address inputs (A₀–A₃) and produces a 3 of 6 code on the six output-pins (O₀–O₅). The decoder also features four separate enables, two active HIGH and two active LOW. All four enables must be active before the decoder will produce a 3 of 6 code. Since two of the enables are HIGH and two are LOW, it is possible to route two binary coded lines to four different 93401's to get two additional bits of decoding with no extra packages.

Ordinarily in memory systems, 93400 memory devices will be arranged in a matrix of rows and columns. Each column will store a particular bit and each row of 93400's will be 256 words. A 93401 driver will be used for each row and each column in the matrix. One 93401 can drive up to 32 93400 X or Y address lines. The usual driving scheme is to connect the four LSB's of address to each of the column decoders. The next four bits of address are connected to each of the row decoders. Additional address bits are decoded to the chip selects on the row decoders. Each column decoder drives the Y address lines on up to 32 93400's in a column. Each row decoder drives the address lines on up to 32 93400's in a row.

THE THREE OF SIX CODE

The "3 of 6" code used in the 93400 and produced by the 93401 is a tradeoff between memory chip complexity and pin count. The simplest 256-bit memory chip would be a 16 by 16 matrix of storage cells, with all 16 rows and 16 column select lines brought off chip. The lowest pin count for a 256-bit memory chip would be achieved by fully decoded X and Y select lines reducing the 32 lines of the simple scheme to only 8 lines. However, full binary decoding of the X and Y lines on chip significantly increases to complexity of the memory chip. The 93400 and 93401 are designed to gain the good features of both alternatives. The 16 X and Y lines are decoded into 6 lines each, allowing the memory to fit into a 16-lead package and still keeping the memory chip fairly simple, since the 3 of 6 code does not require a complex decoder. The table on the right below shows the conversion of 4-bit binary to 3 of 6 code by the 93401, and also the internal column or row selected by the 3 of 6 to 1 of 16 decoder inside the 93400.

TTL LOAD AND DRIVE FACTORS

93400 • 93400B

93401

INPUT	LOAD	INPUT	LOAD
X Lines Y Lines WE	0.33/0.125	E ₀ , E ₁ E ₂ , E ₃ A ₀ , A ₁ , A ₂ , A ₃	0.33/0.25
OUTPUT	DRIVE FACTOR	OUTPUT	DRIVE FACTOR
Output I/O	Open Collector 3.1	O ₀ , O ₁ , O ₂ , O ₃ , O ₄ , O ₅	16/6

Numerator = HIGH level load
(1 load = 0.06 mA)
Denominator = LOW level load
(1 load = 1.6 mA)

CODE CONVERSION EQUATIONS

$$O_0 = \overline{A_3}$$

$$O_1 = (A_1 + A_0) (\overline{A_3} + A_1) (\overline{A_2} + A_0)$$

$$O_2 = (\overline{A_1} + \overline{A_0}) (\overline{A_3} + A_0) (A_2 + A_1)$$

$$O_3 = (\overline{A_1} + A_0) (\overline{A_3} + A_0) (\overline{A_2} + A_1)$$

$$O_4 = (\overline{A_1} + A_0) (\overline{A_3} + A_1) (\overline{A_2} + A_0)$$

$$O_5 = \overline{A_2}$$

TRUTH TABLE

BINARY INPUT TO 93401				3 OF 6 CODE OUTPUT OF 93401; INPUT TO 93400 (L = 0 OR X OR Y)						93400 93400B INTERNAL X OR Y ADDRESS
A ₃	A ₂	A ₁	A ₀	L ₀	L ₁	L ₂	L ₃	L ₄	L ₅	Row or Column
L	L	L	L	H	H	L	L	L	H	0
L	L	L	H	H	L	H	L	L	H	1
L	L	H	L	H	L	L	H	L	H	2
L	L	H	H	H	L	L	L	L	H	3
L	H	L	L	H	H	H	L	L	L	4
L	H	L	H	H	L	H	L	L	H	5
L	H	H	L	H	H	L	H	L	L	6
L	H	H	H	H	L	L	H	H	L	7
H	L	L	L	L	H	L	H	L	H	8
H	L	L	H	L	H	H	L	L	H	9
H	L	H	L	L	L	L	H	H	H	10
H	L	H	H	L	L	H	L	H	H	11
H	H	L	L	L	H	H	H	L	L	12
H	H	L	H	L	H	H	L	H	L	13
H	H	H	L	L	H	L	H	H	L	14
H	H	H	H	L	L	L	H	H	L	15

NOTE: Enables on 93401 must be LLHH. Any other state on the enable inputs causes 93401 outputs to go LOW, and addresses no internal row or column in the 93400 memory matrix.

FAIRCHILD TTL MEMORY 93400 • 93400B • 93401

93400 • 93400B ELECTRICAL CHARACTERISTICS ($T_C = 0^\circ\text{C}$ to 75°C in operation; $V_{CC} = 5.0\text{ V} \pm 5\%$) (Part No. 93400XC/93400BXC) *

SYMBOL	PARAMETER	LIMITS			UNITS	CONDITIONS AND COMMENTS	
		0°C MIN. MAX.	25°C MIN. TYP. MAX.	75°C MIN. MAX.			
V_{OL}	Output LOW Voltage	0.45	0.20 0.45	0.45	Volts	$I_{OL} = 5\text{ mA}$ $I_{OL} = 10\text{ mA}$	$V_{CC} = 4.75\text{ V}$, See Figure 3.
				0.55			
I_{CE}	Output Leakage Current	100	100	100	μA	$V_{CC} = 5.25\text{ V}$, $V_{CE} = 4.5\text{ V}$ All Inputs Grounded	
V_{IL}	Address, Write Input LOW Voltage	0.85	0.85	0.85	Volts	Guaranteed LOW Input Threshold	
V_{IH}	Address, Write Input HIGH Voltage	2.0	2.0	2.0	Volts	Guaranteed HIGH Input Threshold	
I_{FI}	Data Input Forward Current	-250	-250	-250	μA	$V_{CC} = 5.25\text{ V}$, $V_F = 0.45\text{ V}$	
I_{FX}	X Address Input Forward Current	-250	-250	-250	μA	$V_F = 0.45\text{ V}$, $V_{CC} = 5.25\text{ V}$ 2 other X Lines. 3 Y Lines @ 4.5 V Remaining X and Y Lines @ .45 V	
I_{FY}	Y Address Input Forward Current	-250	-250	-250	μA	$V_F = 0.45\text{ V}$, $V_{CC} = 5.25\text{ V}$ 2 other Y Lines. 3 X Lines @ 4.5 V Remaining X and Y Lines @ .45 V	
I_{RX}	Address Input Leakage Current	20	20	20	μA	$V_{CC} = 5.25\text{ V}$, $V_R = 4.5\text{ V}$ Other X and Y inputs grounded	
I_{RY}	Leakage Current	20	20	20			
I_{FW}	Write Input Forward Current	-250	-250	-250	μA	$V_{CC} = 5.25\text{ V}$, $V_F = 0.45\text{ V}$	
I_{RW}	Write Input Leakage Current	20	20	20	μA	$V_{CC} = 5.25\text{ V}$, $V_R = 4.5\text{ V}$	
I_{CC}	Power Supply Current		100 140		mA	$V_{CC} = 5.0\text{ V}$, all inputs at ground	

93401 ELECTRICAL CHARACTERISTICS ($T_C = 0^\circ\text{C}$ to 75°C in operation; $V_{CC} = 5.0\text{ V} \pm 5\%$) (Part No. 93401XC) *

SYMBOL	PARAMETER	LIMITS			UNITS	CONDITIONS	
		0°C MIN. MAX.	+25°C MIN. TYP. MAX.	+75°C MIN. MAX.			
V_{OH}	Output HIGH Voltage	2.4	2.4 3.0	2.4	Volts	$V_{CC} = 4.75\text{ V}$, $I_{OH} = 1.0\text{ mA}$ V_{IL} = value indicated below on this table	
V_{OL}	Output LOW Voltage	0.45	0.3 0.45	0.45	Volts	$V_{CC} = 4.75\text{ V}$, $I_{OL} = 10\text{ mA}$	
V_{IH}	Input HIGH Voltage	2.0	2.0	2.0	Volts	Guaranteed input HIGH threshold for all inputs	
V_{IL}	Input LOW Voltage	0.85	0.85	0.85	Volts	Guaranteed input LOW threshold for all inputs	
I_{FA}	Add. Input Load Current	-0.4	-0.4	-0.4	mA	$V_{CC} = 5.25\text{ V}$	$V_F = 0.45\text{ V}$, $V_R = 4.5\text{ V}$ on other inputs
I_{FE}	Enable Input Load Current	-0.4	-0.4	-0.4	mA	$V_{CC} = 5.25\text{ V}$	
$I_{RA} \& I_{RE}$	Input Leakage Current	20	20	20	μA	$V_{CC} = 5.25\text{ V}$, $V_R = 4.5\text{ V}$, Gnd. on other inputs	
I_{CC}	Power Supply Current	140	120 140	140	mA	$V_{CC} = 5.25\text{ V}$, all inputs at ground	

*X = package type; F for Flatpak, D for Ceramic Dip, P for Plastic Dip. See Packaging Information Section for packages available on this product.

93401 SWITCHING CHARACTERISTICS ($V_{CC} = 5.0\text{ V}$, $T_A = 25^\circ\text{C}$) (See Fig. 2)

SYMBOL	PARAMETER	LIMITS				UNITS
		$C_L = 90\text{ pF}$ (Equiv. to 32 X Lines)		$C_L = 500\text{ pF}$ (Equiv. to 32 Y Lines)		
		TYP.	MAX.	TYP.	MAX.	
$t_{A^{++}}, t_{A^{+-}}$ $t_{A^{-+}}, t_{A^{--}}$	Delay from address going LOW or HIGH to output going LOW or HIGH	20	25	30	40	ns
$t_{E^{++}}, t_{E^{+-}}$ $t_{E^{-+}}, t_{E^{--}}$	Delay from enable going active or inactive to output going HIGH or LOW	20	25	30	40	ns

FAIRCHILD TTL MEMORY 93400 • 93400B • 93401

93400 • 93400B SWITCHING CHARACTERISTICS ($V_{CC} = 5.0\text{ V}$, $T_A = 25^\circ\text{ C}$) $C_L = 47\text{ pF}$; Equivalent to eight OR-tied 4100 outputs

SYMBOL	PARAMETER	93400			93400B			UNITS
		LIMITS			LIMITS			
		MIN	TYP	MAX	MIN	TYP	MAX	
t_{AX}	Read Access Time. Time from good X address to good data at output	30	70	100	30	100	200	ns
t_{AY}	Read Access Time. Time from good Y address to good data at output	15	45	65		45	100	ns
t_{RR}	Read Recovery Time. Time for output to go HIGH after removal of address.			100			150	ns
t_{WP}	Write Pulse Width. Width of pulse on WE required to write data into memory.	80			100			ns
t_{SH}	Data Setup Time. Time HIGH or LOW data must be present before end of write pulse to write proper data into memory.			$t_{WP}+10$ 70 (Note 2)			100 70 (Note 3)	ns
t_{SL}								ns
t_{RH}	Data Release Time. This is the minimum set-up time. Removal of data after the release time will not affect the data written into the memory. See note 1.	0			0			ns
t_{RL}		10			10			ns
C_O	Output Capacitance		7.0			7.0		pF
C_{AX}	Input Capacitance for X address line		3.0			3.0		pF
C_{AY}	Input Capacitance for Y address line		15			15		pF
t_{AS}	Address Set Up Time. Time address must be good before end of write pulse during write operation. (See Fig. 3b)	80			80			ns
t_{AP}	Address Pulse Width. Time that address must remain good for write operation. (See Fig. 3b)	100			100			ns
t_{WR}	Write Recovery Time. Time in write-read cycle from end of write pulse to valid output data.			120			120	ns

NOTES:

- (1) The set up and release times define a window during which devices are responding to the data and/or address. Inputs must remain good at all times in between the set up and release time limits.
- (2) Applies for write pulse less than 150 ns.
- (3) Applies for write pulse more than 160 ns.

Fig. 1a—93400 TYPICAL READ CYCLE

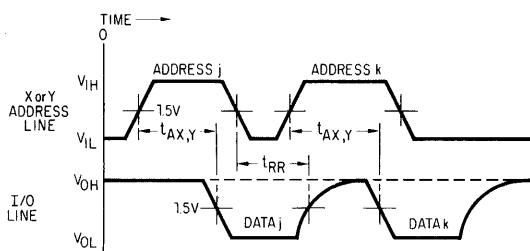

$t_{AX, Y}$ is the time from a good address to good data on the output. Note that the access time may be overlapped with the recovery time to improve speed on consecutive read operations.

Fig. 1b—93400 WRITE CYCLE

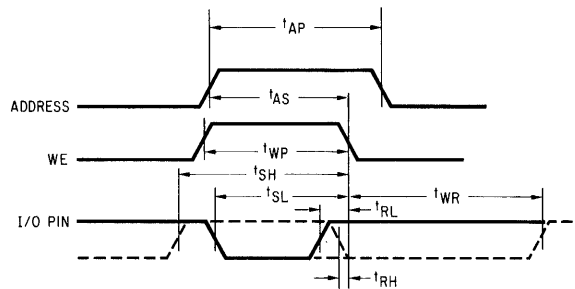

The address must be maintained for 100 ns. The simplest write cycle is achieved by applying the data, then simultaneously raising the address and write pulses for 100 ns. If the write pulse width is less than 100 ns, then the address should come up at about the same time as the write pulse and should be held on after the write pulse. The address should not be applied more than 25 ns before the write pulse, because an early address will cause a read operation to begin disrupting data on the I/O lines (see t_{RR}). For a longer write pulse the address pulse may appear anytime as long as it starts before t_{AS} and lasts at least t_{AP} .

Fig. 2—93401 SWITCHING WAVEFORMS AND TEST LOAD CONDITIONS

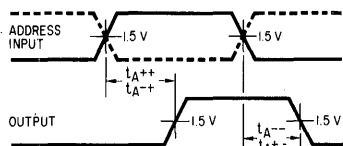
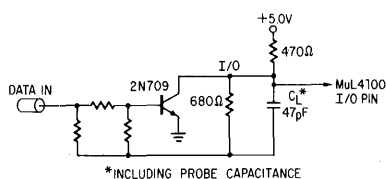

Fig. 3
93400
TEST LOAD CONDITIONS



LOW Level ≤ 0.45 V
HIGH Level ≥ 3.0 V
Rise, Fall Time = 10 ± 5 ns

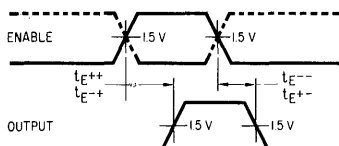

Fig. 4
93400 STANDARD
INPUT PULSE

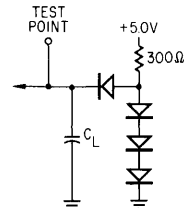
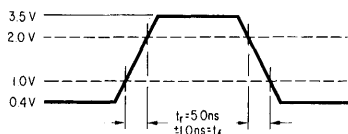
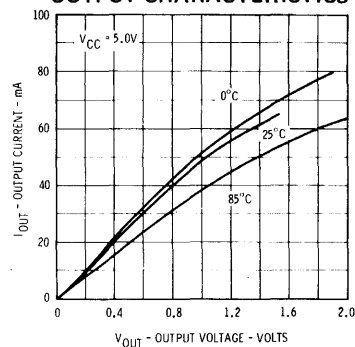

Fig. 5
93400 • 93400B
OUTPUT CHARACTERISTICS



The timing curves in Figures 8 through 13 are obtained using the pulse shape in Figure 6 and the loading in Figure 5. In Figures 12 and 13 the C_L value in the load is varied.

Fig. 6
INPUT THRESHOLD VOLTAGE
VERSUS TEMPERATURE

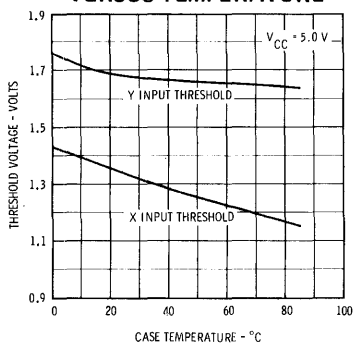

Fig. 7
X ACCESS TIME
VERSUS TEMPERATURE

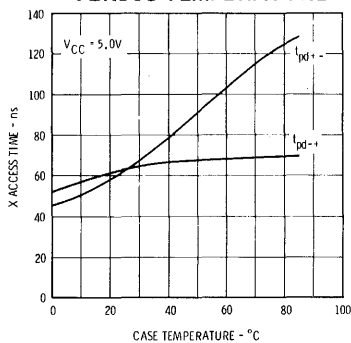

Fig. 8
Y ACCESS TIME
VERSUS TEMPERATURE

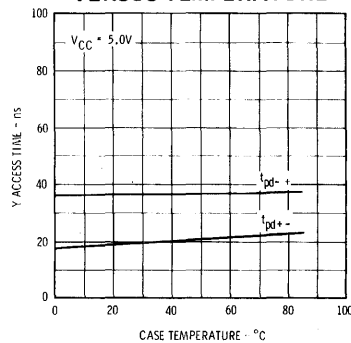

Fig. 9
MINIMUM WRITE PULSE
WIDTH VERSUS TEMPERATURE

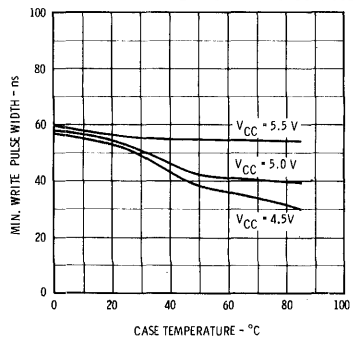

Fig. 10
X ACCESS TIME VERSUS
LOAD CAPACITANCE

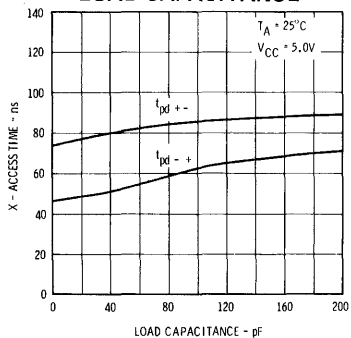
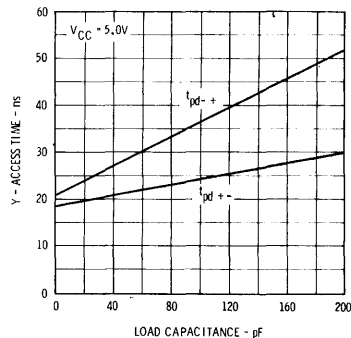

Fig. 11
Y ACCESS TIME VERSUS
LOAD CAPACITANCE



TTL MEMORY 93402

16-BIT ASSOCIATIVE/CONTENT ADDRESSABLE MEMORY

FORMERLY 4102

DESCRIPTION – The 93402 is a high speed 16-Bit Associative Random Access Memory. It is a linear select 4-word by 4-bit array which performs the equality search on all bits in parallel. The 93402 is TTL compatible.

With the bit enable lines ($\bar{E}_0 - \bar{E}_3$) LOW, the outputs ($M_0 - M_3$) go HIGH if associated stored data matches the descriptor bits ($\bar{D}_0 - \bar{D}_3$). If a bit enable line is held HIGH, a match is forced on the corresponding bit in all the words regardless of the state of the descriptor bit ($\bar{D}_0 - \bar{D}_3$). An inverter is connected to the match output M_0 to give its negation \bar{M}_0 .

A word is addressed by having an active LOW on the appropriate address line ($\bar{A}_0 - \bar{A}_3$). Any number of words may be addressed simultaneously.

Data can be written into the memory through the data inputs ($\bar{D}_0 - \bar{D}_3$) under control of the address inputs and the appropriate bit enable ($\bar{E}_0 - \bar{E}_3$) when the write enable (\bar{WE}) is LOW.

Reading can occur either during an equality search or a write operation. If a single word is addressed that word will appear at the data outputs ($\bar{O}_0 - \bar{O}_3$). If multiple addressing is used, the word appearing at the data output is the AND (positive logic) or the OR (negative logic) of the addressed words.

All outputs are uncommitted collectors allowing maximum flexibility in output connection. In many applications such as memory expansion, the outputs of many 93402's can be tied together. In other applications, the wired-OR is not used. In either case an external pull up resistor must be used to attain a HIGH at an output.

- 25 ns TYPICAL MATCH TIME
- MULTIPLE MATCHING AND ADDRESSING
- UNCOMMITTED COLLECTOR OUTPUTS FOR WIRED-OR CAPABILITY
- LINEAR SELECT ADDRESSING
- BIT MASKING

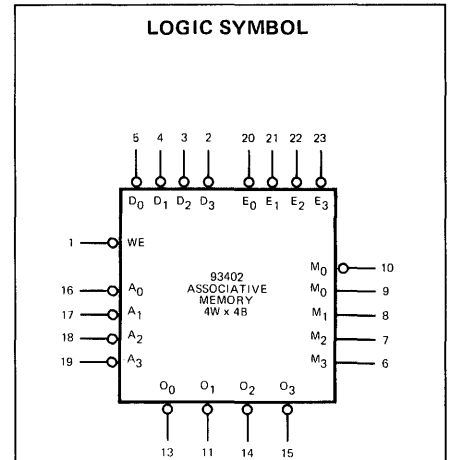

V_{CC} = Pin 24
Gnd = Pin 12

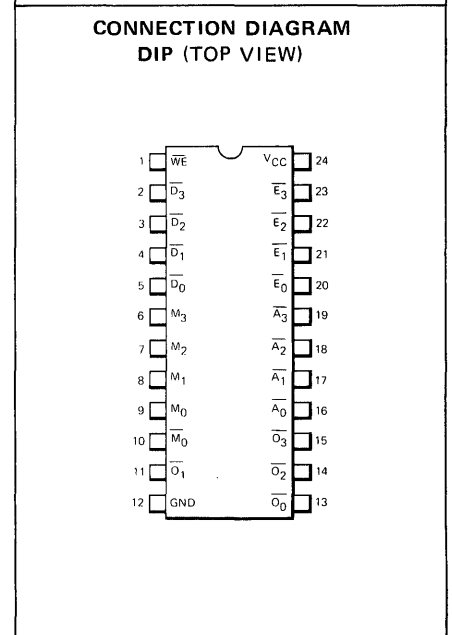
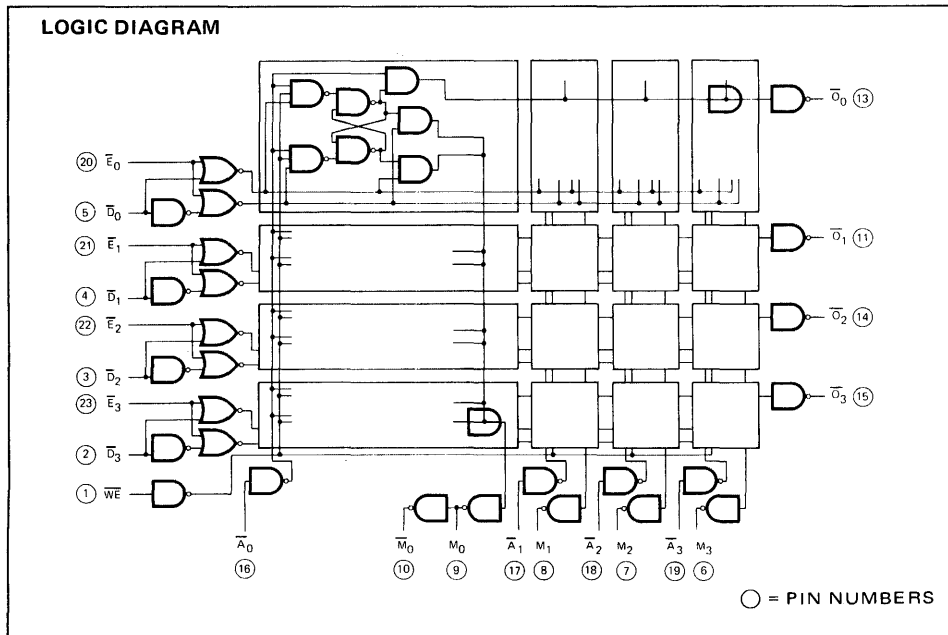

FAIRCHILD TTL MEMORY • 93402

LOADING RULES

	HIGH LEVEL (TTL Unit Loads)	LOW LEVEL (TTL Unit Loads)
Address	1.0	1.0
Bit Enable	1.5	1.5
Write Enable	1.5	1.5
Data Input	1.0	1.0
Data Output	Open Collector	6.2
Match Output [§]	Open Collector	6.2

1 Unit Load (U.L.) = 60 μ A HIGH/1.6 mA LOW.

The external pull-up resistor R is selected to lie in the range as shown.

$$\frac{5.1}{10 - \text{F.O. (1.6)}} \leq R \leq \frac{2.1}{\text{NL} + \text{F.O. (0.06)}}$$

R is in k Ω

N = number of wired-OR outputs

F.O. = number of TTL loads driven

L = Sum of all I_{CEX} of wired-OR outputs

The minimum value of R is limited by output current sinking ability. The maximum value of R is determined by the output and input leakage current (I_{CEX} and I_I) which must be supplied to hold the output at 2.4 V.

F.O.	Maximum number of Wired-OR's
1	66
2	52
3	38
4	24
5	10
5.7	0

ABSOLUTE MAXIMUM RATINGS (above which the useful life may be impaired)

Storage Temperature	-65°C to +150°C
Temperature (Ambient) Under Bias	-55°C to +125°C
V _{CC} Pin Potential to Ground	-0.5 V to +7.0 V
Input Pin Voltage	-0.5 V to +5.5 V
Current into Output Terminal	50 mA
Output Voltage	-0.5 V to +8.0 V

ELECTRICAL CHARACTERISTICS (T_A = 0°C to 75°C, V_{CC} = 5.0 V \pm 5%) (units are pulse tested) (Part No. 93402XC)*

SYMBOL	PARAMETER	LIMITS			UNITS	CONDITIONS
		0°C MIN. MAX.	+25°C MIN. MAX.	+75°C MIN. MAX.		
I _{FA}	Address Input Load Current	-1.6	-1.6	-1.6	mA	V _{CC} = 5.25 V, V _A = 0.45 V
I _{FB}	Bit Enable Load Current	-2.4	-2.4	-2.4	mA	V _{CC} = 5.25 V, V _{CS} = 0.45 V
I _{FWE}	Write Enable Load Current	-2.4	-2.4	-2.4	mA	V _{CC} = 5.25 V, V _W = 0.45 V
I _{FI}	Data Input Load Current	-1.6	-1.6	-1.6	mA	V _{CC} = 5.25 V, V _D = 0.45 V
I _{RA}	Address Input Leakage Current	60	60	60	μ A	V _{CC} = 5.25 V, V _A = 4.5 V
I _{RBE}	Bit Enable Input Leakage Current	90	90	90	μ A	V _{CC} = 5.25 V, V _{CS} = 4.5 V
I _{RWE}	Write Enable Leakage Current	90	90	90	μ A	V _{CC} = 5.25 V, V _W = 4.5 V
I _{RI}	Data Input Leakage Current	60	60	60	μ A	V _{CC} = 5.25 V, V _D = 4.5 V
I _{CEX}	Output Leakage Current (Note 4)	50	50	50	μ A	V _{CC} = 5.25 V, V _{CEX} = 5.25 V
I _{CEX M₀}	Output Leakage Current for M ₀	110	110	110	μ A	V _{CC} = 5.25 V, V _{CEX} = 5.25 V
V _{OL}	Output LOW Voltage (Note 5)	0.45	0.45	0.45	V	V _{CC} = 4.75 V, I _{OL} = 10 mA One Word Addressed
V _{IL}	Input LOW Voltage (Note 6)	0.85	0.85	0.85	V	V _{CC} = 5.0 V, Monitor Appropriate Output To Guarantee This Test Limit
V _{IH}	Input HIGH Voltage (Note 6)	2.0	2.0	2.0	V	V _{CC} = 5.0 V, Monitor Appropriate Output To Guarantee This Test Limit
I _{CC}	Supply Current	125	125	125	mA	V _{CC} = 5.25 V, Worst Case

*X = package type; F for Flatpak, D for Ceramic Dip, P for Plastic Dip. See Packaging Information Section for packages available on this product.

NOTES:

- (4) For all outputs except M₀.
- (5) For all outputs.
- (6) For all inputs

FAIRCHILD TTL MEMORY • 93402

SWITCHING CHARACTERISTICS ($T_A = 25^\circ\text{C}$, $V_{CC} = 5.0\text{ V}$)

SYMBOL	PARAMETER	LIMIT (ns)		LOAD	CONDITIONS C	NOTE
		TYP.	MAX.			
t_{AO-}	Address to Output Turn-On Delay	20	30	10 mA	30 pF	1
t_{AO+}	Address to Output Turn-Off Delay	25	35	10 mA	30 pF	1
t_{DM+}	Descriptor to Output Match Turn-On Delay	25	35	10 mA	30 pF	2
t_{DM-}	Descriptor to Output Match Turn-Off Delay	30	40	10 mA	30 pF	2
t_{WP}	Write Pulse Width Required to Write	33	40	10 mA	30 pF	
t_{WO}	Write Delay	50	80	10 mA	30 pF	
t_s	Maximum Set-up Time on Data Input	33	40	10 mA	30 pF	3
t_r	Release Time (Minimum Set-up Time) on Data Input	0	19	10 mA	30 pF	3

NOTES:

- (1) To test t_{AO+} and t_{AO-} a LOW must be stored in the cell under test.
- (2) To test t_{DM-} and t_{DM+} , a mismatch must occur in at least one bit of the word under test
- (3) Setup and release times are measured with respect to the rising edge of the Write enable. To guarantee writing in the correct data, the data input must be good by t_s and remain good until after t_r .

The typical capacitance of one 93402 output is 7.0 pF.

SWITCHING WAVEFORMS

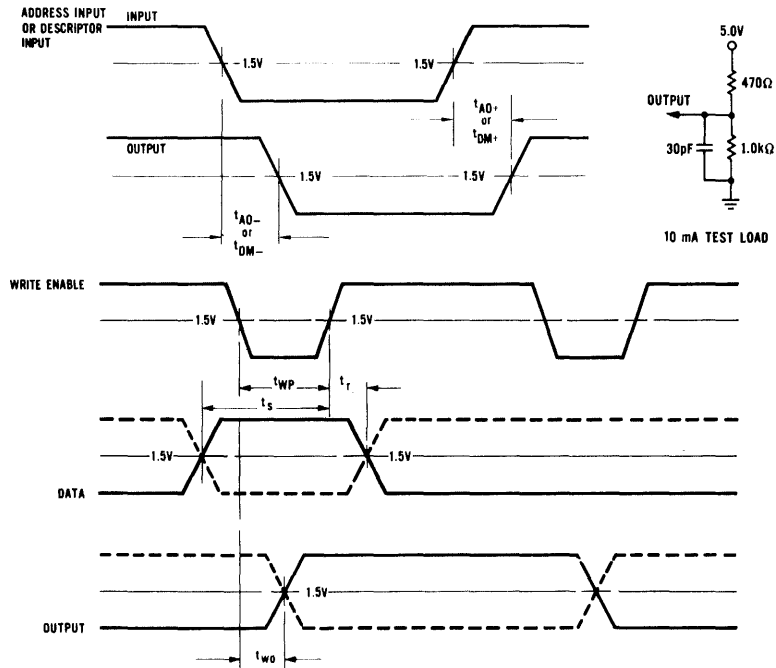

TYPICAL ELECTRICAL CHARACTERISTICS

DATA AND ADDRESS INPUT LOAD CURRENT VERSUS INPUT VOLTAGE

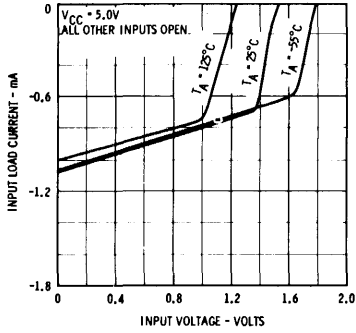

WRITE ENABLE AND BIT ENABLE INPUT LOAD CURRENT VERSUS INPUT VOLTAGE

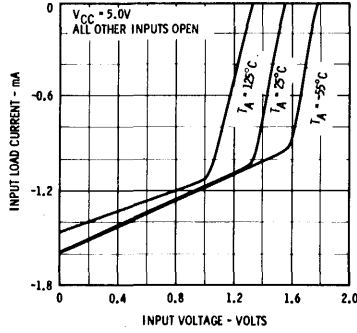

OUTPUT CURRENT VERSUS OUTPUT SATURATION VOLTAGE ALL OUTPUTS

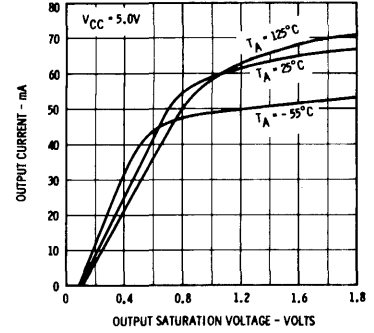

ADDRESS TO OUTPUT DELAY TIME VERSUS AMBIENT TEMPERATURE

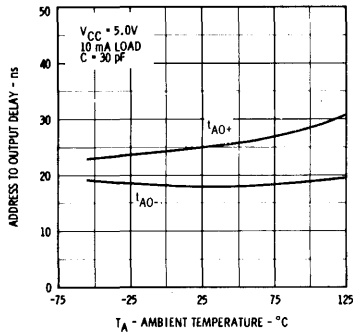

DESCRIPTOR TO OUTPUT DELAY TIME VERSUS AMBIENT TEMPERATURE

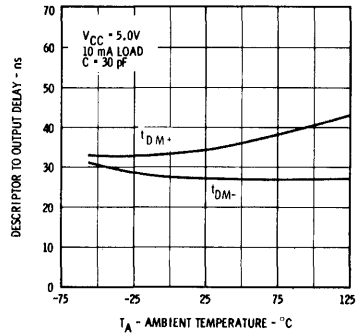

ADDRESS TO OUTPUT DELAY TIME VERSUS LOAD CAPACITANCE

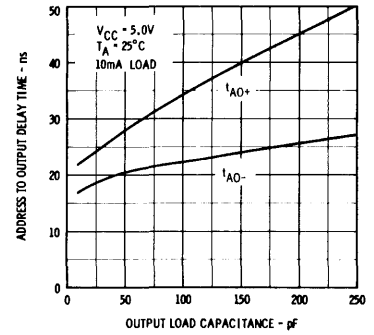

DESCRIPTOR TO OUTPUT DELAY TIME VERSUS LOAD CAPACITANCE

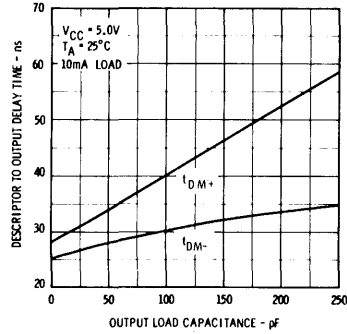

WORST CASE WRITE PULSE WIDTH VERSUS AMBIENT TEMPERATURE

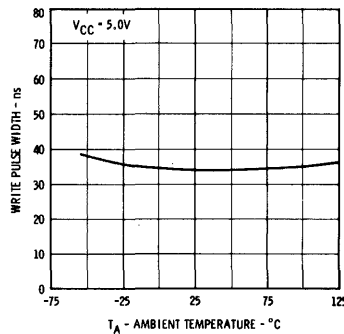

TTL MEMORY 93403

64-BIT FULLY DECODED READ/WRITE MEMORY

FORMERLY 4103

DESCRIPTION – The 93403 is a high speed 64-Bit Read/Write Memory organized 16 words by four bits. Four address lines are buffered and decoded "on chip" for word selection. The 93403 is made with TTL circuitry and all inputs are equivalent to one TTL load.

OPERATION – When the 93403 receives a LOW at the Chip Select (\overline{CS}) input, the binary address (A_0, A_1, A_2 and A_3) is decoded to select one of sixteen 4-bit words. If the Write Enable (\overline{WE}) is at a HIGH level, the contents of the selected word are non-destructively read out and the sense amplifier outputs ($\overline{O}_0, \overline{O}_1, \overline{O}_2$ and \overline{O}_3) reflect the state of the stored data in the four bits of the selected word. If the Write Enable is LOW, the data present on the Data Input lines (D_0, D_1, D_2 and D_3) is written into the four bits of the selected word. Note that there is inversion through the device in a read operation.

- OUTPUT WIRED-OR CAPABILITY
- ON CHIP DECODING
- NON-DESTRUCTIVE READOUT
- CHIP SELECT FOR SYSTEM WORD EXPANSION
- TTL COMPATIBLE

ABSOLUTE MAXIMUM RATINGS (above which the useful life may be impaired)

Storage Temperature	-65°C to + 150°C
Temperature (Case) Under Bias	-55°C to + 125°C
V _{CC} Pin Potential to Ground	-0.5 V to + 8.0 V
Input Pin Voltage	-1.5 V to + 5.5 V
Current Into Output Terminal	100 mA
Output Voltage (external circuit dependent)	-0.5 V to + 8.0 V

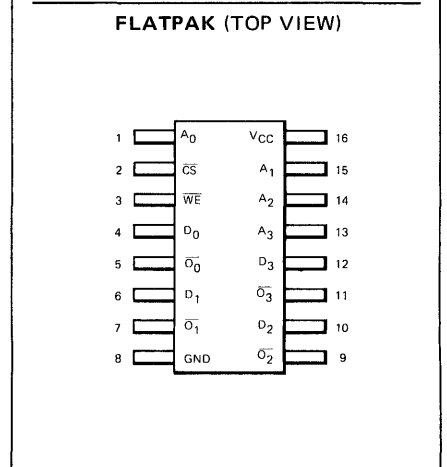
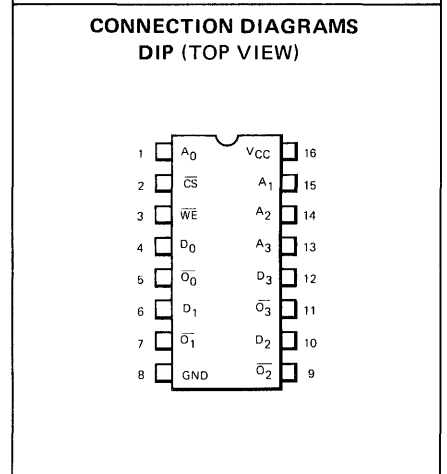
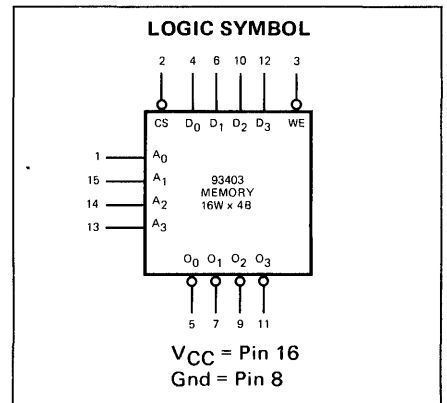
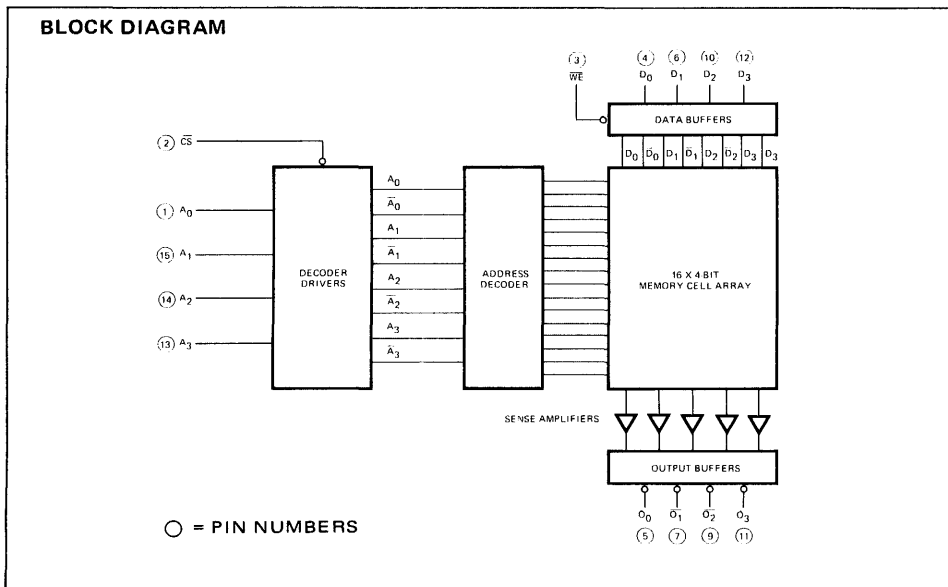

FAIRCHILD TTL MEMORY • 93403

ELECTRICAL CHARACTERISTICS ($T_{case} = 0^{\circ}C$ to $75^{\circ}C$, $V_{CC} = 5.0 V \pm 5\%$) (units are pulse tested) (Part No. 93403XC)

SYMBOL	TEST	LIMITS						UNITS	CONDITIONS
		0°C		+ 25°C		+ 75°C			
		MIN.	MAX.	MIN.	MAX.	MIN.	MAX.		
I_{FA}	Address Input Load Current	-1.6		-1.6		-1.6		mA	$V_{CC} = 5.25 V$, $V_A = 0.45 V$
I_{FCS}	Chip Select Load Current	-1.6		-1.6		-1.6		mA	$V_{CC} = 5.25 V$, $V_{CS} = 0.45 V$
I_{FWE}	Write Enable Load Current	-1.6		-1.6		-1.6		mA	$V_{CC} = 5.25 V$, $V_W = 0.45 V$
I_{FD}	Data Input Load Current	-1.6		-1.6		-1.6		mA	$V_{CC} = 5.25 V$, $V_D = 0.45 V$
I_{RA}	Address Input Leakage Current	60		60		60		μA	$V_{CC} = 5.25 V$, $V_A = 4.5 V$
I_{RCS}	Chip Select Input Leakage Current	60		60		60		μA	$V_{CC} = 5.25 V$, $V_{CS} = 4.5 V$
I_{RWE}	Write Enable Leakage Current	60		60		60		μA	$V_{CC} = 5.25 V$, $V_W = 4.5 V$
I_{RD}	Data Input Leakage Current	60		60		60		μA	$V_{CC} = 5.25 V$, $V_D = 4.5 V$
I_{CEX}	Output Leakage Current	100		100		100		μA	$V_{CC} = 5.25 V$, $V_{CEX} = 5.25 V$ 3.0 on Chip Select
V_{OL}	Output LOW Voltage	0.45		0.45		0.45		V	$V_{CC} = 4.75 V$, $I_{OL} = 16 mA$ $\overline{CS} = V_{IL}$, $\overline{WE} = V_{IH}$
V_{IL}	Input LOW Voltage	0.85		0.85		0.85		V	$V_{CC} = 5.0 V$, Monitor Appropriate Output To Guarantee This Test Limit
V_{IH}	Input HIGH Voltage	2.0		2.0		2.0		V	$V_{CC} = 5.0 V$, Monitor Appropriate Output To Guarantee This Test Limit
I_{CC}	Supply Current	110		110		110		mA	$V_{CC} = 5.25 V$, Write Enable = 3.0 V, other inputs Grounded
V_{CD}	Clamp Diode Voltage, All Inputs	-1.0		-1.0		-1.0		V	$I_{CD} = -5.0 mA$
BV_X	Breakdown Voltage, All Inputs	5.5		5.5		5.5		V	$I_X = 1.0 mA$

X = package type; F for Flatpak, D for Ceramic Dip, P for Plastic Dip. See Packaging Information Section for packages available on this product.

SWITCHING CHARACTERISTICS

SYMBOL	CHARACTERISTIC	DEFINITION	LIMITS			UNITS
			25°C			
			MIN.	TYP.	MAX.	
t_A	Read Access Time	Time From Switching Address Or Chip Select To Data At Output	45	60		ns
t_{SR}	Sense Recovery Time	Time From Switching Address Or Chip Select To Output HIGH	45	60		ns
t_{WP}	Write Pulse	Write Pulse Width - Width of Pulse Guaranteed to Write	45	30		ns
t_{WR}	Write Recovery Time	Time From Write Pulse Going HIGH to Output LOW			65	ns
t_{DH}	Data Hold Time	Time From Write Pulse Going HIGH to Change Data Or Address			5.0	ns
t_{DS}	Data Set-Up Time	Time Data Must Be Present Before Write Pulse	5.0	0		ns
t_{AS}	Address Strobe Time	Time Address Must Be Present in Order to Write	5.0	10	45	ns

WAVEFORMS

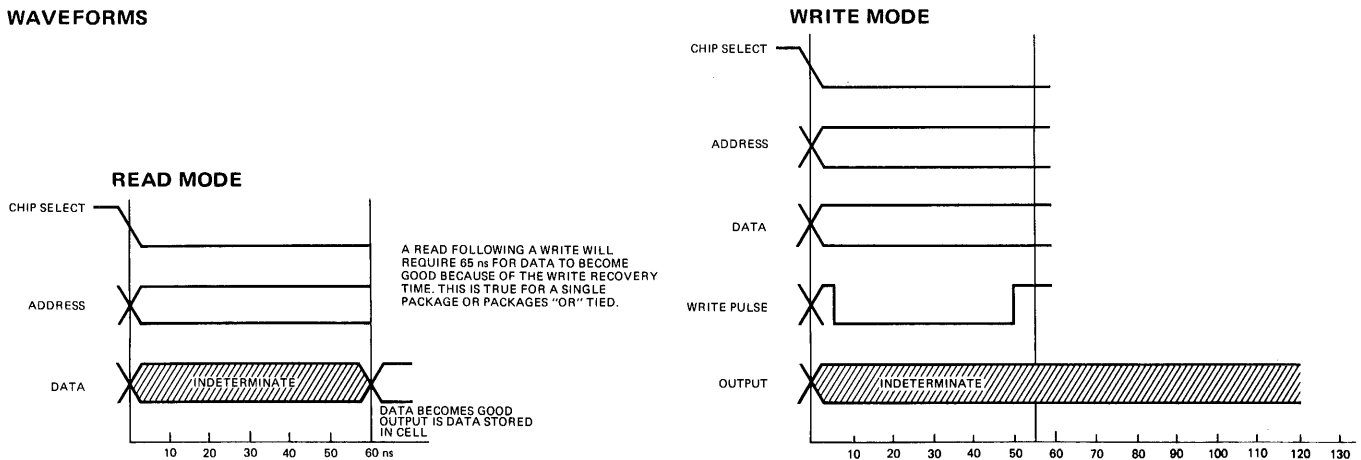

TYPICAL ELECTRICAL CHARACTERISTICS

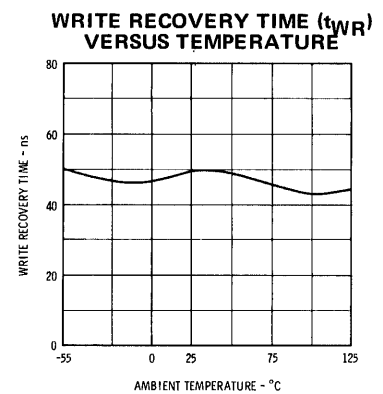
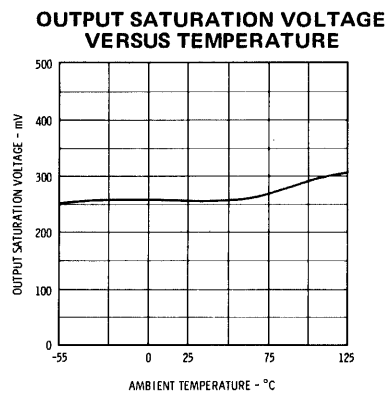
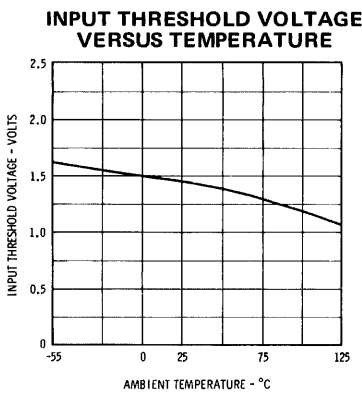
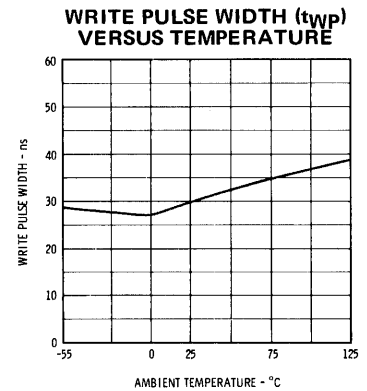
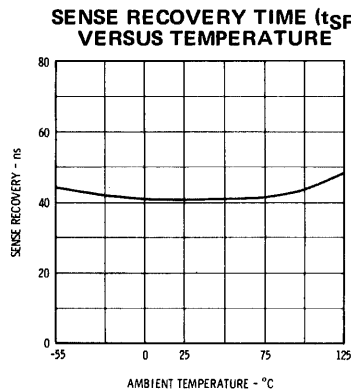
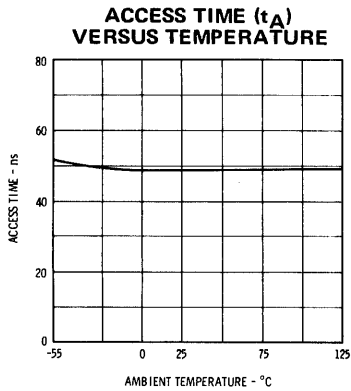

TTL LOADING RULES

	HIGH LEVEL	LOW LEVEL
Address	1 U. L.	1 U. L.
Chip Select	1 U. L.	1 U. L.
Write Enable	1 U. L.	1 U. L.
Data Input	1 U. L.	1 U. L.
Data Output	Open Collector	10 U. L.

- 1 LOW Level TTL Unit Load (U.L.) = 1.6 mA
- 1 HIGH Level TTL Unit Load (U.L.) = 60 μ A

Uncommitted collector outputs are provided on the 93403 to allow maximum flexibility in output connection. In many applications such as memory expansion, the outputs of many 93403 can be tied together. In other applications the wired-OR is not used. In either case an external pullup resistor of value R_L must be used to provide a HIGH at the output when it is off. Any value of R_L within the range specified below may be used.

$$\frac{5.05}{16 - F.O. (1.6)} \leq R_L \leq \frac{2.1}{N (0.1) + F.O. (0.06)}$$

R_L is in $k\Omega$
 N = number of wired-OR outputs
 $F.O.$ = number of TTL loads driven
 $V_{CC} = 5.0 V \pm 10\%$

The minimum value of R_L is limited by output current sinking ability. The maximum value of R_L is determined by the output and input leakage current (I_{CEX} and I_R) which must be supplied to hold the output at 2.4 V.

TRUTH TABLE

WE	CS	OUTPUT	MODE
H	H	HIGH No Glitches	Not Read
L	H	Indeterminate Output	Not Write
H	L	Function of Data Stored in Cell	Read
L	L	Indeterminate Output	Write

SWITCHING TEST CIRCUIT
15 mA LOAD

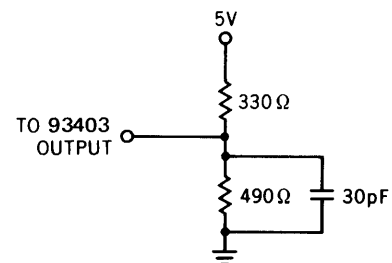

TTL MEMORY 93406

1024-BIT READ ONLY MEMORY

DESCRIPTION – The Fairchild 93406 is a 1024-bit Bipolar Read Only Memory organized 256 words by four bits. An 8-bit binary address is used to select the desired word. The four outputs are uncommitted collectors which permit "OR" tying of the outputs for expanding the memory in the word direction. The customer can specify the active level of the 2-input chip select gate, \overline{CS}_1 and \overline{CS}_2 both will be active LOW unless otherwise specified by the customer. The programmable enable feature allows expansion of the memory to 1024 words without any external gates.

The contents of the memory are mask programmed to the customers specification. The customer can specify the desired ROM code on either the 93406 Coding Form(s) or by punched cards using the 93406 Data Card Format.

- DTL AND TTL COMPATIBLE
- ACCESS TIME – 50 ns MAX
- FULLY DECODED – ON CHIP ADDRESS DECODER AND BUFFER
- 2 CHIP SELECT INPUTS PROVIDING EASY MEMORY EXPANSION
- PROGRAMMABLE CHIP SELECTS
- OR-TIE CAPABILITY
- STANDARD 16-LEAD DUAL IN-LINE PACKAGE

PIN NAMES

A_0 to A_7
 \overline{CS}_1 , \overline{CS}_2
 O_0 to O_3

Address Inputs
 Chip Select Inputs
 Data Outputs

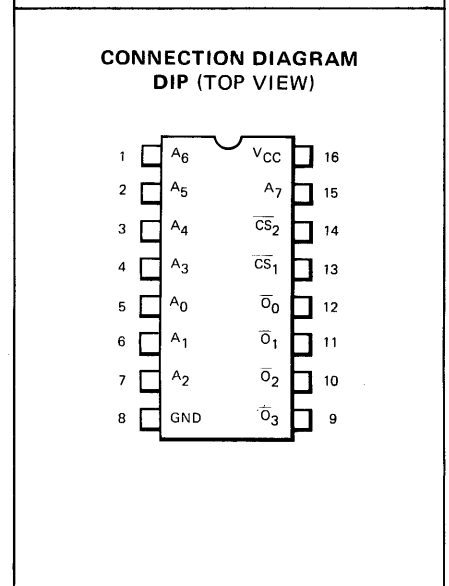
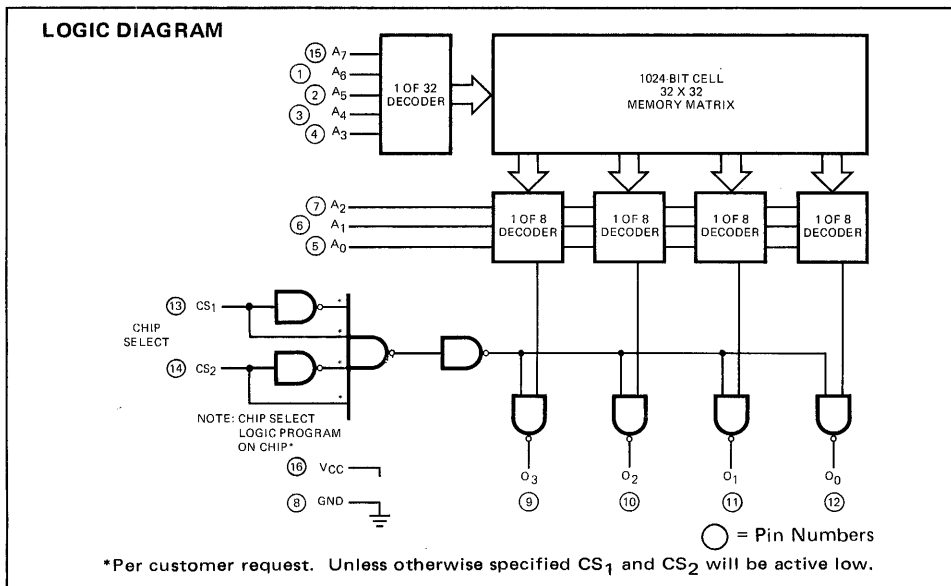
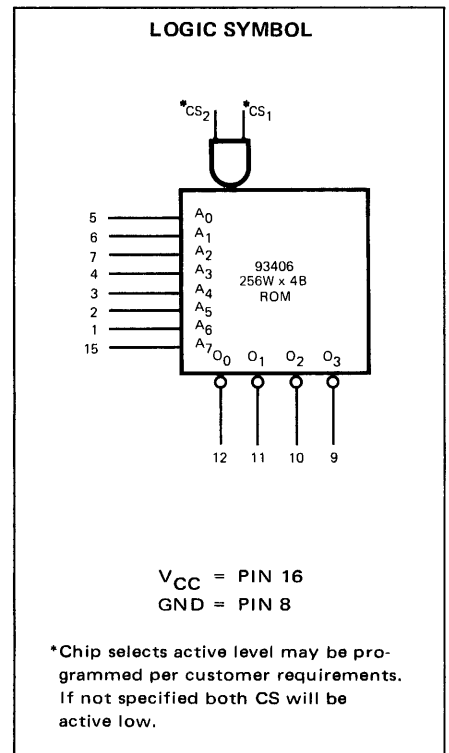

93406 DATA CARD FORMAT

The most efficient method of ordering the 93406 is to punch the desired truth table on a punched card in the format described below. Fairchild will generate mask and test program data directly from these inputs. This eliminates the chance of error when transcribing inputs from a hand written truth table.

Data should be provided on a deck of 34 standard 80 column cards containing the following information.

CARD NO. 1 – Customer Identification

Column	Content
1	Blank
2–28	Customer Name, Drawing or Specification control number.
29–32	Blank
33–39	FAIRCHILD PART NUMBER. This part number is supplied by the factory through your Fairchild sales representative.
40–64	Blank
65–72	Date
73–80	Blank

CARD NO. 2 – Chip Select Option

Column	Content
1–11	Punch "Chip Select"
12	Blank
13, 14	Punch Charts '00', '01', '10' or '11', depending on the chip select code option. (First bit represents CS ₁ input, second bit represents CS ₂ input. '0' = LOW, '1' = HIGH.)
15–32	Blank
33–39	Repeat FAIRCHILD PART NUMBER (This is used for positive identification).
40–80	Blank

CARDS NO. 3 through 34 – Truth Table Deck

Each card will contain instructions for the output levels for 8 input words.

Column	Content
1–7	Punch the numerals representing the first and last words on that card (i.e.: 000-007, 008-015, 016-023. . .248-255). Word order is determined by the value of the binary address – A ₇ = MSB, A ₀ = LSB.
8–9	Blank
10–13	Punch the desired combination of "1's" and "0's" representing the output levels for outputs O ₃ , O ₂ , O ₁ and O ₀ (in that order), for the first word on the card, '0' = LOW, '1' = HIGH.
14	Blank
15–18	Punch the desired combination of "1's" and "0's" representing the output levels for the second word on the card.
19	Blank
20–23	Punch the desired combination of "1's" and "0's" representing the output levels for the third word on the card.
24	Blank
25–28	Punch the desired combination of "1's" and "0's" representing the output levels for the fourth word on the card.
29	Blank
30–33	Punch the desired combination of "1's" and "0's" representing the output levels for the fifth word on the card.
34	Blank

FAIRCHILD TTL MEMORY • 93406

CARDS NO. 3 through 34 – Truth Table Deck (cont'd)

Column	Content
35–38	Punch the desired combination of "1's" and "0's" representing the output levels for the sixth word on the card.
39	Blank
40–43	Punch the desired combination of "1's" and "0's" representing the output levels for the seventh word on the card.
44	Blank
45–48	Punch the desired combination of "1's" and "0's" representing the output levels for the eighth word on the card.
49	Blank
50–51	Repeat chip select code option as in columns 13 and 14 of card number 2.
52–59	Blank
60–66	Repeat FAIRCHILD PART NUMBER (this number is used for positive identification).
67	Blank
68–80	Use optional.

93406 Address Scheme

The 93406 is organized 256 words by 4-bits. The words are numbered 0 through 255 and are addressed using sequential addressing of address inputs A_0 through A_7 , with A_0 as the least significant digit.

WORD	INPUTS							
	Pin 15 A_7	Pin 1 A_6	Pin 2 A_5	Pin 3 A_4	Pin 4 A_3	Pin 7 A_2	Pin 6 A_1	Pin 5 A_0
WORD 0	0	0	0	0	0	0	0	0
WORD 1	0	0	0	0	0	0	0	1
WORD 2	0	0	0	0	0	0	1	0
WORD 3	0	0	0	0	0	0	1	1
↓	↓	↓	↓	↓	↓	↓	↓	↓
WORD 255	1	1	1	1	1	1	1	1

FAIRCHILD TTL MEMORY • 93406

ABSOLUTE MAXIMUM RATINGS

Storage Temperature	-65°C to +150°C
Temperature (Ambient) Under Bias	0°C to +75°C
V _{CC} Pin Potential to Ground	-0.5 V to +8.0 V
Input Pin Voltage	-1.5 V to +5.5 V
Current into Output Terminal	100 mA
Output Voltages	-0.5 V to V _{CC} Value

DC ELECTRICAL CHARACTERISTICS (T_A = 0°C to +75°C, V_{CC} = 5.0 V ±5%)

SYMBOL	CHARACTERISTIC	LIMITS			UNITS	CONDITIONS
		MIN.	TYP.	MAX.		
I _{CEX}	Output Leakage Current			40	μA	V _{CC} = 5.25 V, V _{CEX} = 5.25V Address any HIGH output
V _{OL}	Output LOW Voltage			0.45	Volts	V _{CC} = 4.75 V, I _{OL} = 15 mA Address any LOW output
V _{IH}	Input HIGH Voltage	2.0			Volts	Guaranteed Input HIGH Voltage for All Inputs
V _{IL}	Input LOW Voltage			0.85	Volts	Guaranteed Input LOW Voltage for All Inputs
I _F	Input LOW Current				mA	V _{CC} = 5.25 V, V _F = 0.45 V
	I _{FA} (Address Inputs) I _{FCS} (Chip Select Inputs)			0.8 0.8		
I _R	Input HIGH, Current				μA	V _{CC} = 5.25 V, V _R = 4.5 V
	I _{RA} (Address Inputs)			40		
	I _{RCS} (Chip Select Input)			40		
I _{CC}	Power Supply Current		114	130	mA	V _{CC} = 5.25 V, Outputs open Inputs Grounded and Chip Selected
C _O	Output Capacitance		6.5		pF	V _{CC} = 5.0 V, V _O = 5.0 V, f = 1.0 MHz
V _{CD}	Input Clamp Diode Voltage		-0.8	-1.0	Volts	V _{CC} = 4.75 V, I _A = -5.0 mA

TTL LOADING RULES

INPUT	LOADING	
	HIGH	LOW
A ₇ to A ₀	1 U.L.	0.5 U.L.
CS ₁ , CS ₂	1 U.L.	0.5 U.L.

OUTPUTS	DRIVE FACTOR	
	HIGH	LOW
O ₀ to O ₃	OPEN COLLECTOR	9.3

1 U.L. = 40 μA HIGH/1.6 mA LOW

TYPICAL ELECTRICAL CHARACTERISTICS

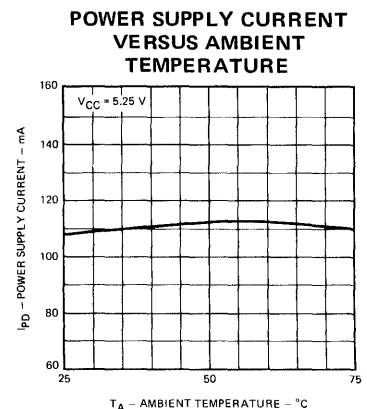
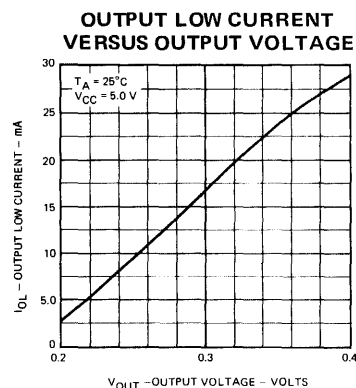
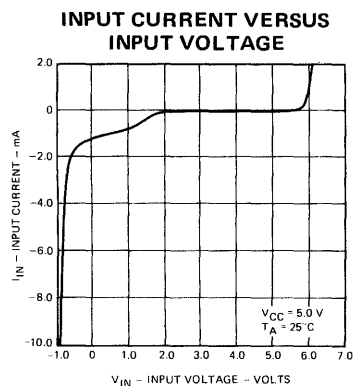

FAIRCHILD TTL MEMORY • 93406

SWITCHING CHARACTERISTICS ($V_{CC} = 5.0\text{ V}$, $T_A = 0^\circ\text{C}$ to $+75^\circ\text{C}$)

SYMBOL	PARAMETER	MIN.	TYP.	MAX.	UNITS	CONDITION
t_{pd++}	Propagation Delay Time, LOW to HIGH Output from Chip Select (or Address) LOW to HIGH		30	50	ns	$C_L = 30\text{ pF}$ $R_{L1} = 300\Omega$ $R_{L2} = 600\Omega$ See Fig. 1
t_{pd+-}	Propagation Delay Time, HIGH to LOW Output from Chip Select (or Address) LOW to HIGH		30	50	ns	
t_{pd-+}	Propagation Delay Time, LOW to HIGH Output from Chip Select (or Address) HIGH to LOW		30	50	ns	
t_{pd--}	Propagation Delay Time, HIGH to LOW Output from Chip Select (or Address) HIGH to LOW		30	50	ns	

NOTE:

First + or - of t_{pd} indicates change in chip select, or address line. Second + or - indicates change in output.

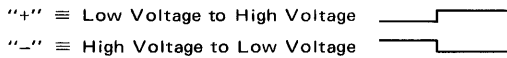

NOTES:

- (1) To test CS delay, apply input pulse to CS input. The word selected must contain a '0' in the bit under test.
- (2) To test t_{pd++} and t_{pd--} delay, apply input pulse to the address input under test. The word selected must contain '0' when the input pulse is LOW, and a '1' when the input pulse is HIGH in the bit under test.
- (3) To test t_{pd+-} and t_{pd-+} delay, apply input pulse to the address input under test. The word selected must contain a '1' when the input pulse is LOW, and a '0' when the input pulse is HIGH in the bit under test.

SWITCHING TEST OUTPUT LOAD

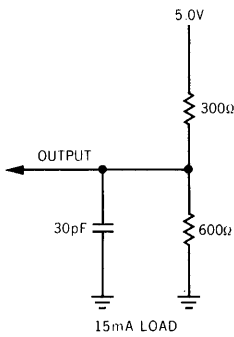
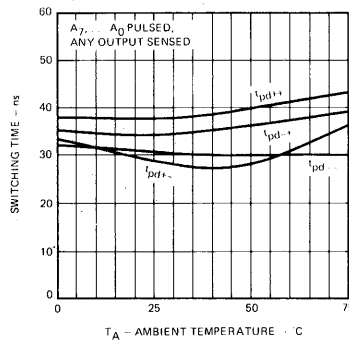
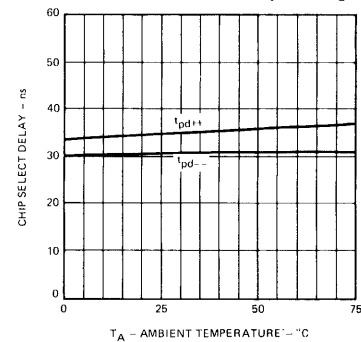

Fig. 1

SWITCHING TIME VERSUS AMBIENT TEMPERATURE



CHIP SELECT DELAY TIME VERSUS AMBIENT TEMPERATURE (CS₁ TO O₀)



SWITCHING WAVEFORMS

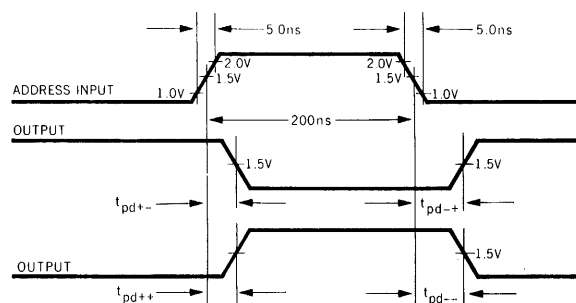
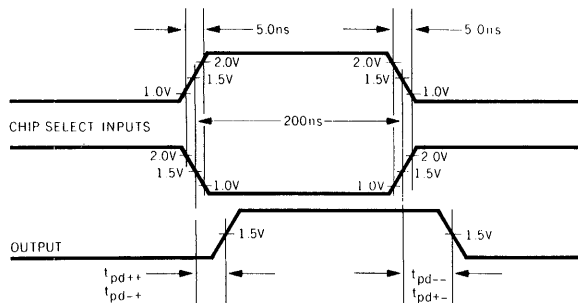

TTL MEMORY 93406

1024-BIT READ ONLY MEMORY

CUSTOMER CODING FORM

CUSTOM ROM TRUTH TABLE

CUSTOMER _____ Location _____

Cust. P/N _____ Cust. Dwg. # _____

Function _____ SL # _____

Chip Select Code – CS₁ (13) = ____, CS₂ (14) = ____.*

*If not specified, ship select code will be '00'. Package pin numbers are shown in parenthesis.

Input								Word #	Output				
MSB	A ₇	A ₆	A ₅	A ₄	A ₃	A ₂	A ₁		A ₀	MSB	O ₃	O ₂	O ₁
0	0	0	0	0	0	0	0	0	0				
0	0	0	0	0	0	0	0	1	1				
0	0	0	0	0	0	0	1	0	2				
0	0	0	0	0	0	0	1	1	3				
0	0	0	0	0	0	1	0	0	4				
0	0	0	0	0	0	1	0	1	5				
0	0	0	0	0	0	1	1	0	6				
0	0	0	0	0	0	1	1	1	7				
0	0	0	0	0	1	0	0	0	8				
0	0	0	0	0	1	0	0	1	9				
0	0	0	0	0	1	0	1	0	10				
0	0	0	0	0	1	0	1	1	11				
0	0	0	0	0	1	1	0	0	12				
0	0	0	0	0	1	1	0	1	13				
0	0	0	0	0	1	1	1	0	14				
0	0	0	0	0	1	1	1	1	15				
15	1	2	3	4	7	6	5	Pkg. Pin #	9	10	11	12	

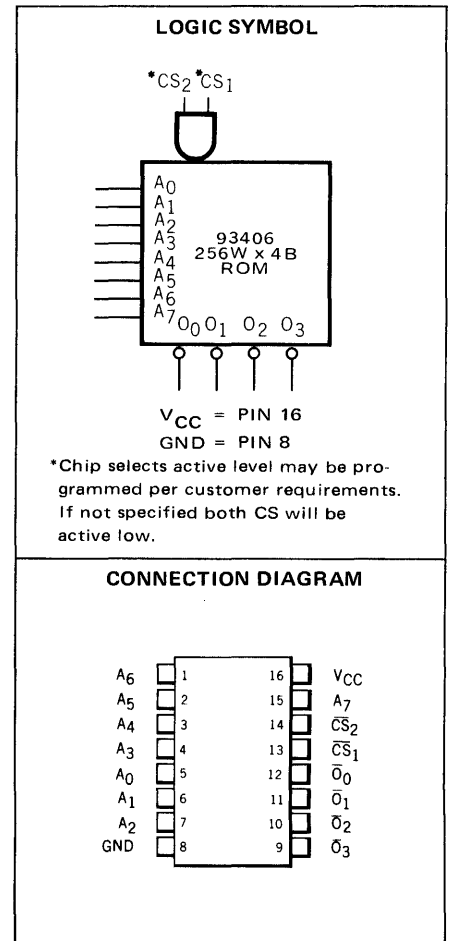

TTL MEMORY 93406

Input								Word #	Output				Input								Word #	Output					
MSB	A ₇	A ₆	A ₅	A ₄	A ₃	A ₂	A ₁		A ₀	MSB	O ₃	O ₂	O ₁	O ₀	MSB	A ₇	A ₆	A ₅	A ₄	A ₃		A ₂	A ₁	A ₀	MSB	O ₃	O ₂
0	0	0	1	0	0	0	0	16						0	0	1	1	0	0	1	1	51					
0	0	0	1	0	0	0	1	17						0	0	1	1	0	1	0	0	52					
0	0	0	1	0	0	1	0	18						0	0	1	1	0	1	0	1	53					
0	0	0	1	0	0	1	1	19						0	0	1	1	0	1	1	0	54					
0	0	0	1	0	1	0	0	20						0	0	1	1	0	1	1	1	55					
0	0	0	1	0	1	0	1	21						0	0	1	1	1	0	0	0	56					
0	0	0	1	0	1	1	0	22						0	0	1	1	1	0	0	1	57					
0	0	0	1	0	1	1	1	23						0	0	1	1	1	0	1	0	58					
0	0	0	1	1	0	0	0	24						0	0	1	1	1	0	1	1	59					
0	0	0	1	1	0	0	1	25						0	0	1	1	1	1	0	0	60					
0	0	0	1	1	0	1	0	26						0	0	1	1	1	1	0	1	61					
0	0	0	1	1	0	1	1	27						0	0	1	1	1	1	1	0	62					
0	0	0	1	1	1	0	0	28						0	0	1	1	1	1	1	1	63					
0	0	0	1	1	1	0	1	29						0	1	0	0	0	0	0	0	64					
0	0	0	1	1	1	1	0	30						0	1	0	0	0	0	0	1	65					
0	0	0	1	1	1	1	1	31						0	1	0	0	0	0	1	0	66					
0	0	1	0	0	0	0	0	32						0	1	0	0	0	0	1	1	67					
0	0	1	0	0	0	0	1	33						0	1	0	0	0	1	0	0	68					
0	0	1	0	0	0	1	0	34						0	1	0	0	0	1	0	1	69					
0	0	1	0	0	0	1	1	35						0	1	0	0	0	1	1	0	70					
0	0	1	0	0	1	0	0	36						0	1	0	0	0	1	1	1	71					
0	0	1	0	0	1	0	1	37						0	1	0	0	1	0	0	0	72					
0	0	1	0	0	1	1	0	38						0	1	0	0	1	0	0	1	73					
0	0	1	0	0	1	1	1	39						0	1	0	0	1	0	1	0	74					
0	0	1	0	1	0	0	0	40						0	1	0	0	1	0	1	1	75					
0	0	1	0	1	0	0	1	41						0	1	0	0	1	1	0	0	76					
0	0	1	0	1	0	1	0	42						0	1	0	0	1	1	0	1	77					
0	0	1	0	1	0	1	1	43						0	1	0	0	1	1	1	0	78					
0	0	1	0	1	1	0	0	44						0	1	0	0	1	1	1	1	79					
0	0	1	0	1	1	0	1	45						0	1	0	1	0	0	0	0	80					
0	0	1	0	1	1	1	0	46						0	1	0	1	0	0	0	1	81					
0	0	1	0	1	1	1	1	47						0	1	0	1	0	0	1	0	82					
0	0	1	1	0	0	0	0	48						0	1	0	1	0	0	1	1	83					
0	0	1	1	0	0	0	1	49						0	1	0	1	0	1	0	0	84					
0	0	1	1	0	0	1	0	50						0	1	0	1	0	1	0	1	85					
15	1	2	3	4	7	6	5	Pkg. Pin #	9	10	11	12	15	1	2	3	4	7	6	5	Pkg. Pin #	9	10	11	12		

TTL MEMORY 93406

Input									Output				Input									Output			
MSB								Word #	MSB				MSB								Word #	MSB			
A ₇	A ₆	A ₅	A ₄	A ₃	A ₂	A ₁	A ₀		O ₃	O ₂	O ₁	O ₀	A ₇	A ₆	A ₅	A ₄	A ₃	A ₂	A ₁	A ₀		O ₃	O ₂	O ₁	O ₀
0	1	0	1	0	1	1	0	86					0	1	1	1	1	0	0	1	121				
0	1	0	1	0	1	1	1	87					0	1	1	1	1	0	1	0	122				
0	1	0	1	1	0	0	0	88					0	1	1	1	1	0	1	1	123				
0	1	0	1	1	0	0	1	89					0	1	1	1	1	1	0	0	124				
0	1	0	1	1	0	1	0	90					0	1	1	1	1	1	0	1	125				
0	1	0	1	1	0	1	1	91					0	1	1	1	1	1	1	0	126				
0	1	0	1	1	1	0	0	92					0	1	1	1	1	1	1	1	127				
0	1	0	1	1	1	0	1	93					1	0	0	0	0	0	0	0	128				
0	1	0	1	1	1	1	0	94					1	0	0	0	0	0	0	1	129				
0	1	0	1	1	1	1	1	95					1	0	0	0	0	0	1	0	130				
0	1	1	0	0	0	0	0	96					1	0	0	0	0	0	1	1	131				
0	1	1	0	0	0	0	1	97					1	0	0	0	0	1	0	0	132				
0	1	1	0	0	0	1	0	98					1	0	0	0	0	1	0	1	133				
0	1	1	0	0	0	1	1	99					1	0	0	0	0	1	1	0	134				
0	1	1	0	0	1	0	0	100					1	0	0	0	0	1	1	1	135				
0	1	1	0	0	1	0	1	101					1	0	0	0	1	0	0	0	136				
0	1	1	0	0	1	1	0	102					1	0	0	0	1	0	0	1	137				
0	1	1	0	0	1	1	1	103					1	0	0	0	1	0	1	0	138				
0	1	1	0	1	0	0	0	104					1	0	0	0	1	0	1	1	139				
0	1	1	0	1	0	0	1	105					1	0	0	0	1	1	0	0	140				
0	1	1	0	1	0	1	0	106					1	0	0	0	1	1	0	1	141				
0	1	1	0	1	0	1	1	107					1	0	0	0	1	1	1	0	142				
0	1	1	0	1	1	0	0	108					1	0	0	0	1	1	1	1	143				
0	1	1	0	1	1	0	1	109					1	0	0	1	0	0	0	0	144				
0	1	1	0	1	1	1	0	110					1	0	0	1	0	0	0	1	145				
0	1	1	0	1	1	1	1	111					1	0	0	1	0	0	1	0	146				
0	1	1	1	0	0	0	0	112					1	0	0	1	0	0	1	1	147				
0	1	1	1	0	0	0	1	113					1	0	0	1	0	1	0	0	148				
0	1	1	1	0	0	1	0	114					1	0	0	1	0	1	0	1	149				
0	1	1	1	0	0	1	1	115					1	0	0	1	0	1	1	0	150				
0	1	1	1	0	1	0	0	116					1	0	0	1	0	1	1	1	151				
0	1	1	1	0	1	0	1	117					1	0	0	1	1	0	0	0	152				
0	1	1	1	0	1	1	0	118					1	0	0	1	1	0	0	1	153				
0	1	1	1	0	1	1	1	119					1	0	0	1	1	0	1	0	154				
0	1	1	1	1	0	0	0	120					1	0	0	1	1	0	1	1	155				
15	1	2	3	4	7	6	5	Pkg. Pin #	9	10	11	12	15	1	2	3	4	7	6	5	Pkg. Pin #	9	10	11	12

TTL MEMORY 93406

Input								Word #	Output				Word #	Output											
MSB	A ₇	A ₆	A ₅	A ₄	A ₃	A ₂	A ₁		A ₀	MSB	O ₃	O ₂		O ₁	O ₀	MSB	O ₃	O ₂	O ₁	O ₀					
1	0	0	1	1	1	0	0	156					191												
1	0	0	1	1	1	0	1	157					192												
1	0	0	1	1	1	1	0	158					193												
1	0	0	1	1	1	1	1	159					194												
1	0	1	0	0	0	0	0	160					195												
1	0	1	0	0	0	0	1	161					196												
1	0	1	0	0	0	1	0	162					197												
1	0	1	0	0	0	1	1	163					198												
1	0	1	0	0	0	0	0	164					199												
1	0	1	0	0	1	0	1	165					200												
1	0	1	0	0	1	1	0	166					201												
1	0	1	0	0	1	1	1	167					202												
1	0	1	0	1	1	0	0	168					203												
1	0	1	0	1	0	0	1	169					204												
1	0	1	0	1	0	1	0	170					205												
1	0	1	0	1	0	1	1	171					206												
1	0	1	0	1	1	0	0	172					207												
1	0	1	0	1	1	0	1	173					208												
1	0	1	0	1	1	1	0	174					209												
1	0	1	0	1	1	1	1	175					210												
1	0	1	1	0	0	0	0	176					211												
1	0	1	1	0	0	0	1	177					212												
1	0	1	1	0	0	1	0	178					213												
1	0	1	1	0	0	1	1	179					214												
1	0	1	1	0	1	0	0	180					215												
1	0	1	1	0	1	0	1	181					216												
1	0	1	1	0	1	1	0	182					217												
1	0	1	1	0	1	1	1	183					218												
1	0	1	1	1	0	0	0	184					219												
1	0	1	1	1	0	0	1	185					220												
1	0	1	1	1	0	1	0	186					221												
1	0	1	1	1	0	1	1	187					222												
1	0	1	1	1	1	0	0	188					223												
1	0	1	1	1	1	0	1	189					224												
1	0	1	1	1	1	1	0	190					225												
15	1	2	3	4	7	6	5	Pkg. Pin #	9	10	11	12	15	1	2	3	4	7	6	5	Pkg. Pin #	9	10	11	12

TTL MEMORY 93406

Input								Word #	Output				
MSB	A ₇	A ₆	A ₅	A ₄	A ₃	A ₂	A ₁		A ₀	MSB	O ₃	O ₂	O ₁
1	1	1	0	0	0	1	0	226					
1	1	1	0	0	0	1	1	227					
1	1	1	0	0	1	0	0	228					
1	1	1	0	0	1	0	1	229					
1	1	1	0	0	1	1	0	230					
1	1	1	0	0	1	1	1	231					
1	1	1	0	1	0	0	0	232					
1	1	1	0	1	0	0	1	233					
1	1	1	0	1	0	1	0	234					
1	1	1	0	1	0	1	1	235					
1	1	1	0	1	1	0	0	236					
1	1	1	0	1	1	0	1	237					
1	1	1	0	1	1	1	0	238					
1	1	1	0	1	1	1	1	239					
1	1	1	1	0	0	0	0	240					
1	1	1	1	0	0	0	1	241					
1	1	1	1	0	0	1	0	242					
1	1	1	1	0	0	1	1	243					
1	1	1	1	0	1	0	0	244					
1	1	1	1	0	1	0	1	245					
1	1	1	1	0	1	1	0	246					
1	1	1	1	0	1	1	1	247					
1	1	1	1	1	0	0	0	248					
1	1	1	1	1	0	0	1	249					
1	1	1	1	1	0	1	0	250					
1	1	1	1	1	0	1	1	251					
1	1	1	1	1	1	0	0	252					
1	1	1	1	1	1	0	1	253					
1	1	1	1	1	1	1	0	254					
1	1	1	1	1	1	1	1	255					

15 1 2 3 4 7 6 5 Pkg. Pin # 9 10 11 12

Customers Authorizing Signature _____

Date _____

Qualified FSC Representative _____

Date _____

TTL MEMORY 93407 • 93433

16-BIT COINCIDENT SELECT READ/WRITE MEMORY

FORMERLY 5033 • 9033

DESCRIPTION – These devices are Planar* epitaxial integrated 16-bit, bit-oriented, non-destructive readout memory cells, compatible with Fairchild TTL. These memory cells, organized as 16 words by one bit, are designed for high speed scratch-pad memory applications. The 93407 and 93433 are electrically identical, but with different pin configurations. Both devices are available in two fan out options, 40 mA (A) and 20 mA (B) for Industrial/Commercial temperature range.

OPERATION – The memory cell consists of 16 RS flip-flops arranged in an addressable four-by-four matrix. The desired bit location is selected by raising the coincident X-Y address lines to a logic "H" level (>2.1 volts) and holding the non-selected address lines at logic "L" level (<0.7 volts). As many as four locations may be addressed simultaneously without destroying stored information. The stored data and its complement at the addressed bit location may be read at the output terminals. If the addressed bit location contains a "1", the \overline{S}_1 output will be LOW and the \overline{S}_0 output will be HIGH. If the addressed bit location contains a "0", the \overline{S}_1 output will be HIGH and the \overline{S}_0 output will be LOW.

Writing is accomplished by activating one of the write amplifiers. To write a "1", the desired bit location is addressed and the input of the "write one" (W_1) amplifier is raised to a HIGH level. To write a "0", the input of the "write zero" (W_0) amplifier is raised to a HIGH level.

The outputs are open-collector, which may be wired OR for word expansion. (The output transistors are off when none of the bits are selected.) An external resistor should be returned to V_{CC} to pull-up the wired OR outputs.

- TTL COMPATIBLE
- OUTPUT WIRED-OR CAPABILITY
- TRUE AND COMPLEMENTARY OUTPUTS ARE PROVIDED
- NON DESTRUCTIVE READ OUT
- FAN OUT AVAILABLE IN TWO GRADES: A = 40 mA, B = 20 mA FOR INDUSTRIAL/COMMERCIAL TEMPERATURE RANGE

ABSOLUTE MAXIMUM RATINGS (above which the useful life may be impaired)

Storage Temperature	-65°C to +150°C
Temperature (Ambient) Under Bias	-55°C to +125°C
V_{CC} Pin Potential to Ground	-0.5 V to +8.0 V
Input Pin Voltage	-1.5 V to +5.5 V
Current Into Output Terminal	100 mA
Output Voltage	-0.5 V to +8.0 V

LOGIC DIAGRAM

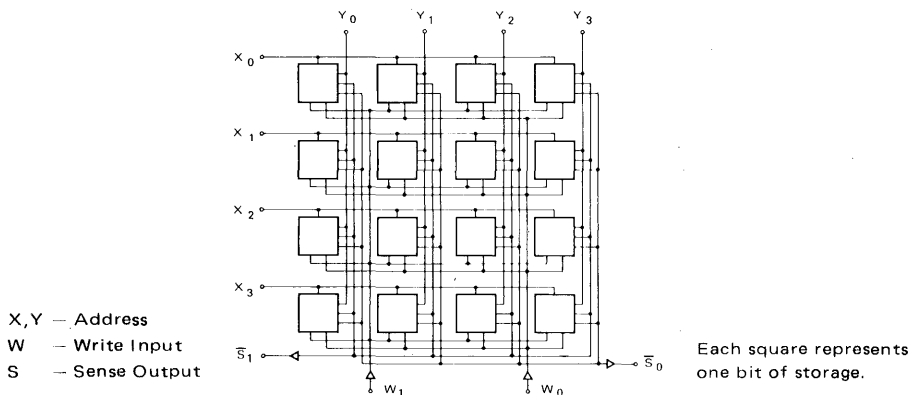

LOGIC SYMBOL

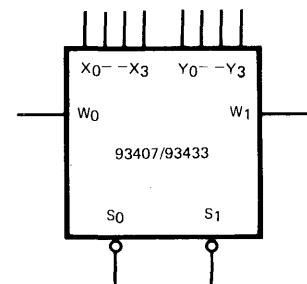

93407
 V_{CC} = Pin 4
 GND = Pin 10

93433
 V_{CC} = Pin 14
 GND = Pin 7

CONNECTION DIAGRAMS
 DIP (TOP VIEW)*

93407

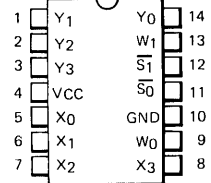

93433

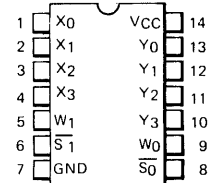

X, Y — ADDRESS
 W — WRITE INPUT
 S — SENSE OUTPUT

*Pin connection is same for all packages.

*Planar is a patented Fairchild process.

FAIRCHILD TTL MEMORY • 93407 • 93433

ELECTRICAL CHARACTERISTICS ($T_A = -55^\circ\text{C}$ to $+125^\circ\text{C}$, $V_{CC} = 5.0\text{V} \pm 10\%$) (Part No. 93407/BXM, 93433/BXM)**

SYMBOL	PARAMETER	LIMITS		UNITS	TEST CONDITIONS
		MIN.	MAX.		
IFX	X Address Input Load Current		11	mA	$V_{CC} = 5.5\text{V}$, $V_X = 0\text{V}$, $V_Y = 4.5\text{V}$, other X inputs grounded
IFY	Y Address Input Load Current		11	mA	$V_{CC} = 5.5\text{V}$, $V_Y = 0\text{V}$, $V_X = 4.5\text{V}$, other Y inputs grounded
IRX	X Address Input Leakage Current		400	μA	$V_{CC} = 5.5\text{V}$, $V_X = 4.5\text{V}$, other X and Y inputs grounded
IRY	Y Address Input Leakage Current		400	μA	$V_{CC} = 5.5\text{V}$, $V_Y = 4.5\text{V}$, other X and Y inputs grounded
IFW	Write Input Load Current		1.5	mA	$V_{CC} = 5.5\text{V}$, $V_W = 0\text{V}$
IRW	Write Input Leakage Current		100	μA	$V_{CC} = 5.5\text{V}$, $V_W = 4.5\text{V}$
ICC	Power Supply Current		65	mA	$V_{CC} = 5.5\text{V}$, All Inputs Grounded
IBV	Power Supply Current at $V_{CC} = 7\text{V}$		84	mA	$V_{CC} = 7.0\text{V}$, All Inputs Grounded
ICEX	Output Leakage Current		250	μA	$V_{CC} = 5.5\text{V}$, $V_{CEX} = 5.5\text{V}$, all inputs grounded
VOL	Output LOW Voltage		0.40	V	$V_{CC} = 4.5\text{V}$, One Bit Selected $I_{OL} = 20\text{mA}$
$V_{XY(W)}$	Address Input Threshold to Prevent Writing		0.75	V*	$V_{CC} = 5.0\text{V}$, other X and Y grounded. Alternately pulse W_0 and W_1 , cell must not change state.
$V_{XY(W)}$	Address Input Threshold to Insure Writing	2.1		V*	$V_{CC} = 5.0\text{V}$, other X and Y grounded. Alternately pulse W_0 and W_1 , cell state must alternate.
$V_{XY(R)}$	Address Input Threshold to Prevent Reading		0.8	V	$V_{CC} = 5.0\text{V}$, other inputs grounded. Both outputs must be on HIGH state.
$V_{XY(R)}$	Address Input Threshold to Insure Reading	2.1		V*	$V_{CC} = 5.0\text{V}$, other X and Y grounded. Alternately pulse W_0 and W_1 , cell state must alternate.
$V_W(W)$	Write Input Threshold to Prevent Writing		0.8	V*	$V_{CC} = 5.0\text{V}$, one X and one Y to 4.5 V, other X and Y grounded. One write input to $V_W(W)$, pulse the other write input. If W_0 is pulsed, S_0 will assume LOW state. If W_1 is pulsed, S_1 will assume LOW state.
$V_W(W)$	Write Input Threshold to Insure Writing	2.1		V*	$V_{CC} = 5.0\text{V}$, one X and one Y to 4.5 V, other X and Y grounded. One write input to $V_W(W)$, pulse the other write input. If W_0 is pulsed, S_1 will assume LOW state. If W_1 is pulsed, S_0 will assume LOW state.

ELECTRICAL CHARACTERISTICS ($T_A = 0^\circ\text{C}$ to 75°C , $V_{CC} = 5.0\text{V} \pm 5\%$) (Part No. 93407/AXC, 93407/BXC, 93433/AXC, 93433/BXC)**

SYMBOL	PARAMETER	LIMITS		UNITS	TEST CONDITIONS
		MIN.	MAX.		
IFX	X Address Input Load Current		11	mA	$V_{CC} = 5.25\text{V}$, $V_X = 0\text{V}$, $V_Y = 4.5\text{V}$, other X inputs grounded
IFY	Y Address Input Load Current		11	mA	$V_{CC} = 5.25\text{V}$, $V_Y = 0\text{V}$, $V_X = 4.5\text{V}$, other X inputs grounded
IRX	X Address Input Leakage Current		400	μA	$V_{CC} = 5.25\text{V}$, $V_X = 4.5\text{V}$, other X and Y inputs grounded
IRY	Y Address Input Leakage Current		400	μA	$V_{CC} = 5.25\text{V}$, $V_Y = 4.5\text{V}$, other X and Y inputs grounded
IFW	Write Input Load Current		1.5	mA	$V_{CC} = 5.25\text{V}$, $V_W = 0\text{V}$
IRW	Write Input Leakage Current		100	μA	$V_{CC} = 5.25\text{V}$, $V_W = 4.5\text{V}$
ICC	Power Supply Current		65	mA	$V_{CC} = 5.25\text{V}$, All Inputs Grounded
IBV	Power Supply Current at $V_{CC} = 7\text{V}$		95	mA	$V_{CC} = 7.0\text{V}$, All Inputs Grounded
ICEX	Output Leakage Current		250	μA	$V_{CC} = 5.25\text{V}$, $V_{CEX} = 5.5\text{V}$, all inputs grounded
VOL	Output LOW Voltage		0.45	V	$V_{CC} = 4.75\text{V}$, One bit selected $I_{OL} = 20\text{mA}$ for IND μ grade. $I_{OL} = 40\text{mA}$ for IND A grade.
$V_{XY(W)}$	Address Input Threshold to Prevent Writing		0.8	V*	$V_{CC} = 5.0\text{V}$, other X and Y grounded. Alternately pulse W_0 and W_1 , cell must not change state.
$V_{XY(W)}$	Address Input Threshold to Insure Writing	2.0		V*	$V_{CC} = 5.0\text{V}$, other X and Y grounded. Alternately pulse W_0 and W_1 , cell state must alternate.
$V_{XY(R)}$	Address Input Threshold to Prevent Reading		1.0	V	$V_{CC} = 5.0\text{V}$, other inputs grounded. Both outputs must be on HIGH state.
$V_{XY(R)}$	Address Input Threshold to Insure Reading	2.0		V*	$V_{CC} = 5.0\text{V}$, other X and Y grounded. Alternately pulse W_0 and W_1 , cell state must alternate.
$V_W(W)$	Write Input Threshold to Prevent Writing		1.0	V*	$V_{CC} = 5.0\text{V}$, one X and one Y to 4.5 V, other X and Y grounded. One write input to $V_W(W)$, pulse the other write input. If W_0 is pulsed, S_0 will assume LOW state. If W_1 is pulsed, S_1 will assume LOW state.
$V_W(W)$	Write Input Threshold to Insure Writing	2.0		V*	$V_{CC} = 5.0\text{V}$, one X and one Y to 4.5 V, other X and Y grounded. One write input to $V_W(W)$, pulse the other write input. If W_0 is pulsed, S_1 will assume LOW state. If W_1 is pulsed, S_0 will assume LOW state.

*Amplitude of the pulse $\geq 2.5\text{V}$, pulse width $\geq 100\text{ns}$. The cell state is determined 35 ns after pulse disappears.

**X = package type; F for Flatpak, D for Ceramic Dip. See Packaging Information Section for packages available on this product.

TTL LOADING RULES

	HIGH LEVEL	LOW LEVEL
Address Input	6.5 U.L.	6.5 U.L.
Write Input	1.5 U.L.	0.9 U.L.
Sense Output	Open Collector	IND A grade = 25 U.L. MIL or IND B grade = 12.5 U.L.

1 Unit Load (U.L.) = 60 μA HIGH/1.6 mA LOW

TYPICAL ELECTRICAL CHARACTERISTICS

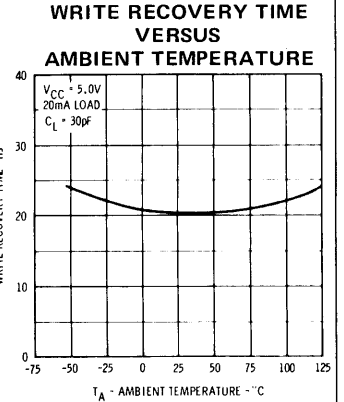
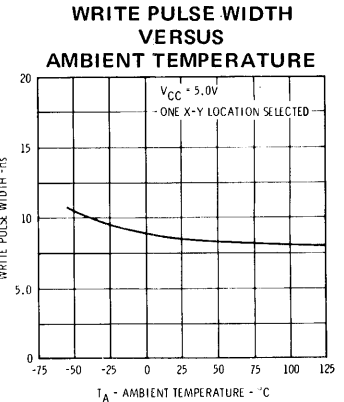
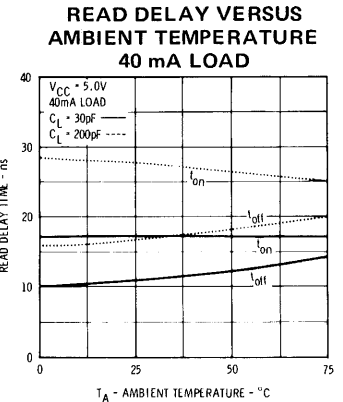
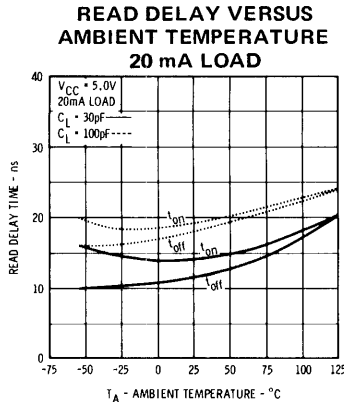
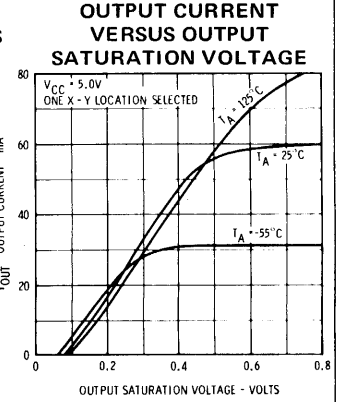
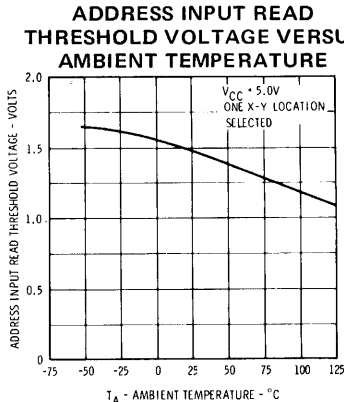
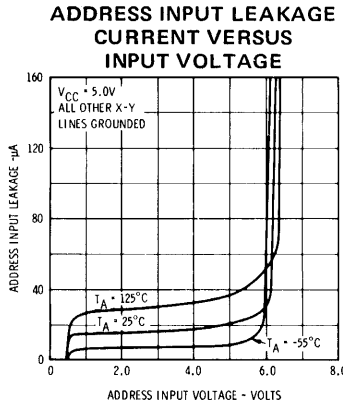
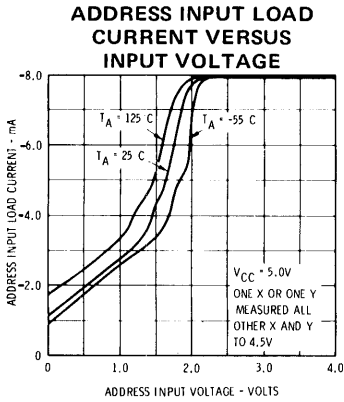

SWITCHING TIME TEST CIRCUIT AND WAVEFORMS

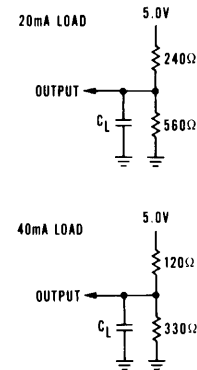
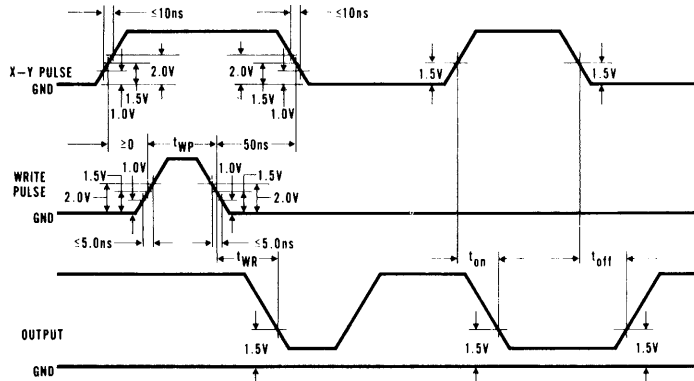

SWITCHING CHARACTERISTICS (TA = 25°C, VCC = 5.0 V, One X-Y Location Selected.)

SYMBOL	PARAMETER	MIL B GRADE		IND A GRADE		IND B GRADE		UNITS	CONDITIONS	
		MIN.	MAX.	MIN.	MAX.	MIN.	MAX.		LOAD (mA)	CL (pF)
t _{WP}	Write Pulse Width	25		25		25		ns	40	
t _{WR}	Write Recovery Time		40		35		35	ns	40	30
t _{on}	Turn On Delay		25		20		20	ns	40	30
			35		30		30		20	100
t _{off}	Turn Off Read Delay				20			ns	40	30
			25		30		20		20	30
			35		30		30		20	100

APPLICATION:

A memory utilizing these memory cells may have any desired word length. The number of words in the memory is a multiple of four words. The following example of a 64 word memory illustrates how a number of 16-bit memory cells may be used to construct a typical memory.

The 64 word memory as shown in Figure A consists of groups of four memory cells. Each of the groups of four memory cells supplies one bit for each of the 64 words stored in the memory. All bits belonging to one word are stored in the same address location. Therefore, the address of a word in the memory is the address of each bit of the addressed word in the groups of four memory cells. The equal outputs of the four memory cells are tied together so that each group of four memory cells has one HIGH and one LOW level output.

The six memory address lines from an external source are decoded at the first level with two 9301 decoders. The fourth input to each of the two decoders can be used as an enable control input to the 64 word memory. If the address enable is at a LOW logic level, one and only one of the eight outputs, 0 to 7, in the illustration assumes a LOW logic level. If the address enable is at a HIGH logic level, the outputs 0 to 7 of the two decoders assume a HIGH logic level, thus none of the 64 words stored in the memory is addressed. The outputs, 0 to 7, of the two decoders serve as X-and-Y address lines. The output signals of the decoders are connected to driving transistors which provide the necessary current to address the memory cells.

The example given above is only one of the many organizations and is presented as an illustration. Obviously many address decoding schemes may be utilized depending on memory size, driver fan out, decoder fan out, wiring, heat dissipation, etc.

Figures B through D show alternative schemes to enter data into the memory cell.

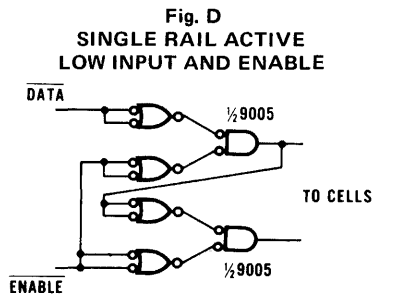
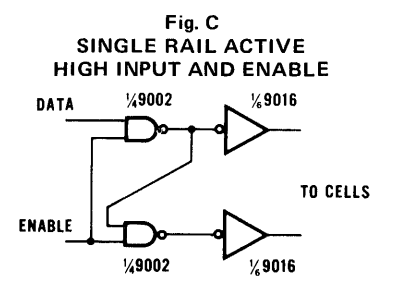
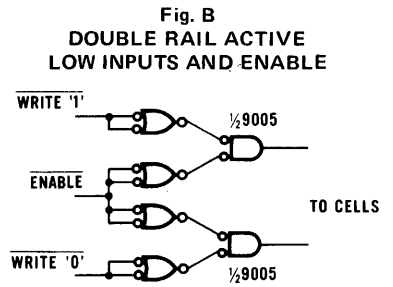
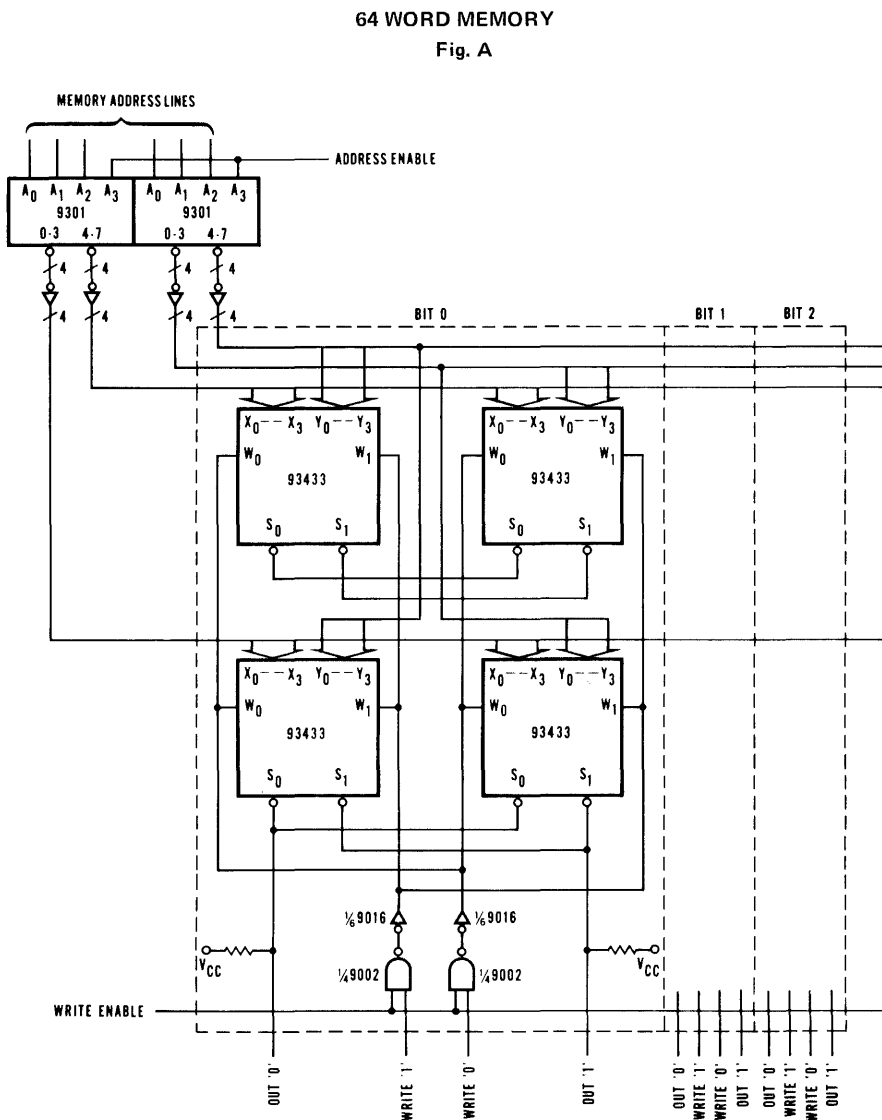

TTL ISOPLANAR MEMORY 93410 • 93410A

256-BIT FULLY DECODED RANDOM ACCESS MEMORY

DESCRIPTION — The 93410 and 93410A are high speed 256 Bit TTL Random Access Memories with full decoding on chip. Each memory, organized as 256 words x 1 bit, is designed for scratch pad, buffer and distributed main memory applications. Both devices have three chip select lines to simplify their use in larger memory systems. Address input pin locations are specifically chosen to permit maximum packaging density and for ease of PC board layout. An uncommitted collector output is provided to permit "OR-ties" for ease of memory expansion.

The 93410A is a high speed version of the 93410, offering a 35 ns access time.

- **ORGANIZATION - 256 WORDS X 1 BIT**
- **THREE HIGH SPEED CHIP SELECT INPUTS**
- **TYPICAL ACCESS TIME**

93410A	Commercial	35 ns
93410	Commercial	45 ns
93410	Military	45 ns
- **NON INVERTED DATA OUTPUT**
- **ON CHIP DECODING**
- **POWER DISSIPATION - 1.8 mW/BIT**
- **POWER DISSIPATION DECREASES WITH TEMPERATURE**

PIN NAMES

\overline{CS}_1 \overline{CS}_2 CS_3	Chip Select Input
A_0 thru A_7	Address Inputs
D_{IN}	Data Input
D_{OUT}	Data Output
\overline{WE}	Write Enable

LOADING

(Notes a & b)

0.5 U.L.
0.5 U.L.
0.5 U.L.
10 U.L.
0.5 U.L.

NOTES:

- a. 1 Unit Load (U.L.) = 40 μ A HIGH/1.6 mA LOW
- b. 10 U.L. is the output LOW drive factor. An external pull up resistor is needed to provide HIGH level drive capability. This output will sink a maximum of 16 mA at $V_{out} = 0.45$ V.

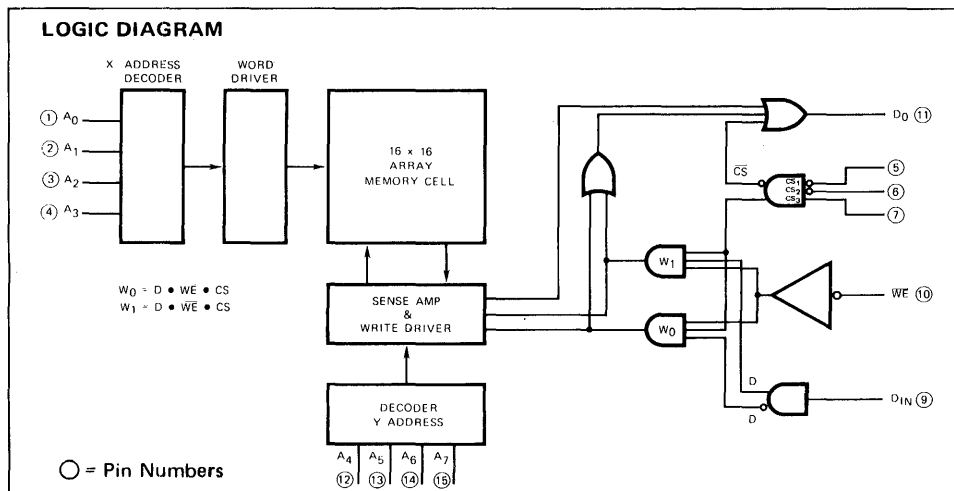
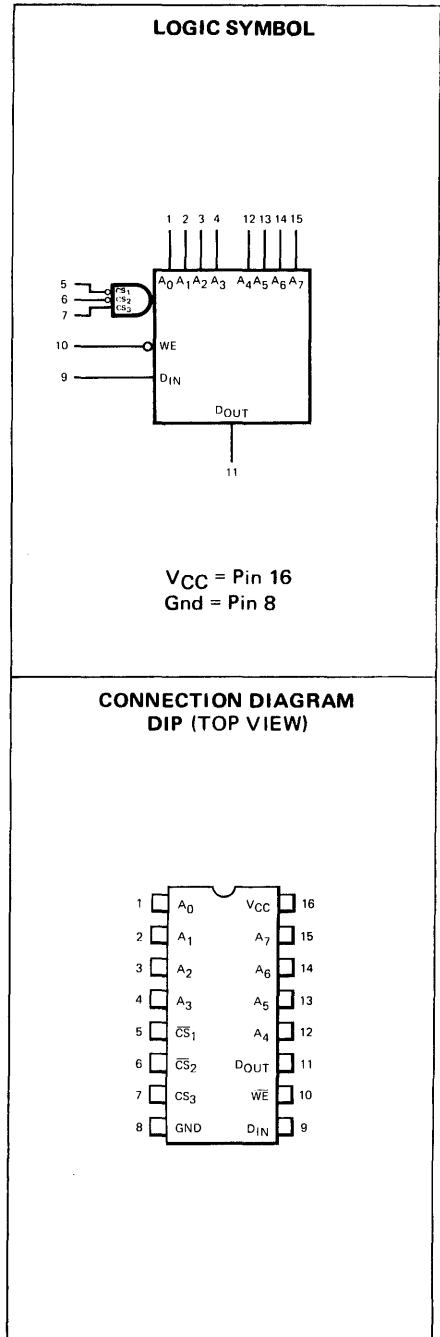

FAIRCHILD ISOPLANAR TTL MEMORY • 93410 • 93410A

FUNCTIONAL DESCRIPTION

The 93410 and 93410A are fully decoded 256-bit Random Access Memories organized 256 words by 1 bit. Bit selection is achieved by means of an 8-bit address, A₀ thru A₇.

Three chip select inputs are provided, two are active LOW (\overline{CS}_1 and \overline{CS}_2) and the third active HIGH (CS₃) for maximum logic flexibility. This permits memory array expansion up to 2048 words without the need for additional external decoders. For larger memories the fast chip select access time permits the decoding of chip select, CS, from the address without increasing address access time.

The read and write operations are controlled by the state of the active LOW Write Enable \overline{WE} (pin 10). With \overline{WE} held LOW and the chip selected, the data at D_{IN} is written into the addressed location. To read, \overline{WE} is held HIGH and the chip selected. Data in the specified location is presented at D_{OUT} and is non-inverted.

Uncommitted collector outputs are provided to allow maximum flexibility in output connection. In many applications such as memory expansion, the outputs of many 93410s or 93410As can be tied together. In other applications the wired-OR is not used. In either case an external pull up resistor of value R_L must be used to provide a HIGH at the output when it is off. Any value of R_L within the range specified below may be used.

$$\frac{V_{CC} \text{ (MAX)}}{16 - \text{F.O. (1.6)}} \leq R_L \leq \frac{V_{CC} \text{ (MIN)} - V_{OH}}{N (I_{CEX}) + \text{F.O. (0.04)}}$$

R_L is in kΩ

N = number of wired-OR outputs tied together

F.O. = number of TTL Unit Loads (U.L.) driven

I_{CEX} = Memory Output Leakage Current in mA

V_{OH} = Required Output HIGH level at Output Node

The minimum value of R_L is limited by output current sinking ability. The maximum value of R_L is determined by the output and input leakage current which must be supplied to hold the output at V_{OH}.

TABLE I – TRUTH TABLE

INPUTS			OUTPUT			MODE
CS			\overline{WE}	DI	DO	
PIN 5	PIN 6	PIN 7				
H	X	X	X	X	H	Not Selected
X	H	X	X	X	H	Not Selected
X	X	L	X	X	H	Not Selected
L	L	H	L	L	H	Write "0"
L	L	H	L	H	H	Write "1"
L	L	H	H	X	DO	Read data from addressed location

H = HIGH Voltage

L = LOW Voltage

X = Don't Care (HIGH or LOW)

ABSOLUTE MAXIMUM RATINGS (above which the useful life may be impaired)

Storage Temperature	-65°C to +150°C
Temperature (Ambient) Under Bias	-55°C to +125°C
V _{CC} Pin Potential to Ground Pin	-0.5 V to +7.0 V
*Input Voltage (dc)	-0.5 V to +5.5 V
*Input Current (dc)	-12 mA to +5.0 mA
**Voltage Applied to Outputs (output HIGH)	0.5 V to +5.50 V
Output Current (dc) (Output LOW)	+20 mA

*Either Input Voltage limit or Input Current limit is sufficient to protect the inputs.

**Output Current Limit Required.

GUARANTEED OPERATING RANGES

PART NUMBER	SUPPLY VOLTAGE (V _{CC})			AMBIENT TEMPERATURE ⁴
	MIN.	TYP.	MAX.	
93410XC, 93410AXC	4.75 V	5.0 V	5.25 V	0°C to 75°C
93410XM	4.75 V	5.0 V	5.25 V	-55°C to +125°C

X = package type; F for Flatpak, D for Ceramic Dip, P for Plastic Dip. See Packaging Information Section for packages available on this product.

FAIRCHILD ISOPLANAR TTL MEMORY • 93410 • 93410A

ELECTRICAL CHARACTERISTICS OVER OPERATING TEMPERATURE RANGE¹ (unless otherwise noted)

SYMBOL	PARAMETER	LIMITS ²			UNITS	CONDITIONS		
		MIN.	TYP. ³	MAX.				
V _{OL}	Output LOW Voltage		0.3	0.45	V	V _{CC} = MIN I _{OL} = 16 mA		
V _{IH}	Input HIGH Voltage	2.0	1.6		V	Guaranteed input logical HIGH voltage for all inputs		
V _{IL}	Input LOW Voltage		1.5	0.85	V	Guaranteed input logical LOW voltage for all inputs		
I _{IL}	Input LOW Current		-530	-800	μA	V _{CC} = MAX., V _{IN} = 0 V		
I _{IH}	Input HIGH Current		1.0	20	μA	V _{CC} = MAX., V _{IN} = 4.5 V		
I _{CEX}	Output Leakage Current		1.0	50	μA	V _{CC} = MAX., V _{OUT} = 4.5 V		
V _{CD}	Input Clamp Diode Voltage		-1.0	-1.5	V	V _{CC} = MAX., I _{IN} = -10 mA		
I _{CC}	Power Supply Current	93410XC		90	135	mA	T _A ≥ 25°C	V _{CC} = MAX. All inputs grounded See Power Supply vs Temp. Curve
				100	140		T _A < 25°C	
		93410XM		90	135		T _A ≥ 25°C	
				100	145		T _A < 25°C	

SWITCHING CHARACTERISTICS OVER OPERATING TEMPERATURE RANGE

SYMBOL	PARAMETER	93410AXC			93410XC			93410XM			UNITS	CONDITIONS
		MIN.	TYP.	MAX.	MIN.	TYP.	MAX.	MIN.	TYP.	MAX.		
READ MODE	DELAY TIMES											
t _{ACS}	Chip Select Access Time		20	24		25	30		25	40	ns	See Test Circuit 5
t _{RCS}	Chip Select Recovery Time		20	25		25	32		25	40	ns	
t _{AA}	Address Access Time		35	45		45	60		45	70	ns	
WRITE MODE	DELAY TIMES											
t _{WS}	Write Disable Time	10	20	35	10	20	40	10	20	50	ns	
t _{WR}	Write Recovery Time		25	35		25	40		25	50	ns	
	INPUT TIMING REQUIREMENTS											
t _w	Minimum Write Pulse Width	30	20		30	25		40	25		ns	See Test Circuit
t _{WSD}	Data Set-up Time Prior to Write	5	0		5	0		5	0		ns	
t _{WHD}	Data Hold Time After Write	5	0		5	0		5	0		ns	
t _{WSA}	Address Set-up Time	5	0		5	0		5	0		ns	
t _{WSCS}	Chip Select Set-up Time	5	0		5	0		5	0		ns	
t _{WHCS}	Chip Select Hold Time	5	0		5	0		5	0		ns	
C _{IN}	Input Pin Capacitance			4.0			4.0			4.0	pF	
C _{OUT}	Output Pin Capacitance			8.0			8.0			8.0	pF	

NOTES:

- Conditions for testing, not shown in the table, are chosen to guarantee operation under "worst case" conditions.
- The specified LIMITS represent the "worst case" value for the parameter. Since these "worst case" values normally occur at the temperature and supply voltage extremes, additional noise immunity and guard banding can be achieved by decreasing the allowable system operating ranges.
- Typical limits are at V_{CC} = 5.0 V, 25°C, and max. loading.
- Guaranteed with transverse airflow exceeding 400 linear F.P.M. and 2 minute warm up.
Typical thermal resistance values of the package are:
θ_{JA} (Junction to Ambient) = 50°C/W (at 400 F.P.M. Airflow)
θ_{JA} (Junction to Ambient) = 90°C/W (Still Air)
θ_{JL} (Junction to Case) = 25°C/W
The -55°C Operating Temperature relates to a -30°C worst case cold Junction Temperature.
- The maximum address access time is guaranteed to be the worst case bit in the memory using a pseudo random testing pattern.

93410 AC TEST LOAD AND WAVEFORM

LOADING CONDITION

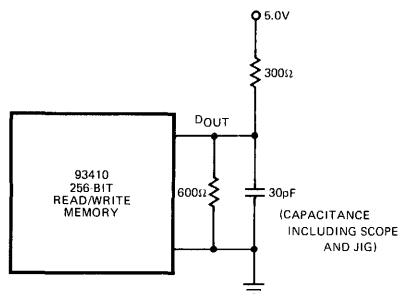

INPUT PULSES

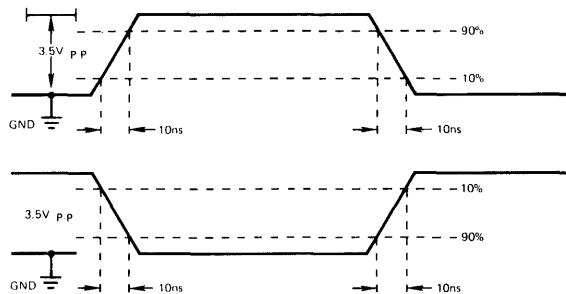

(ALL TIME MEASUREMENTS REFERENCED TO 1.5 V)

SWITCHING WAVEFORMS

READ MODE

PROPAGATION DELAY FROM CHIP SELECT

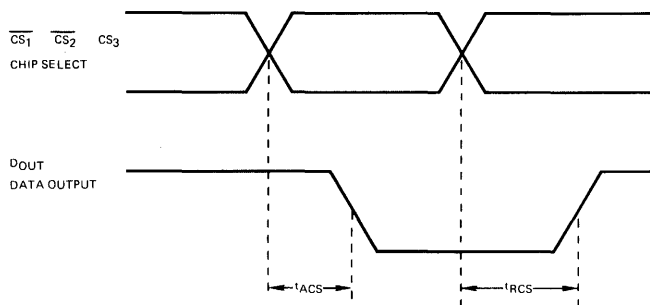

PROPAGATION DELAY FROM ADDRESS

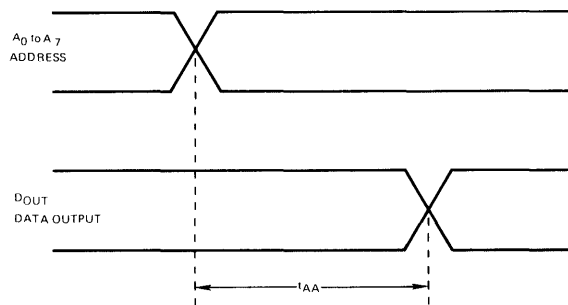

WRITE MODE

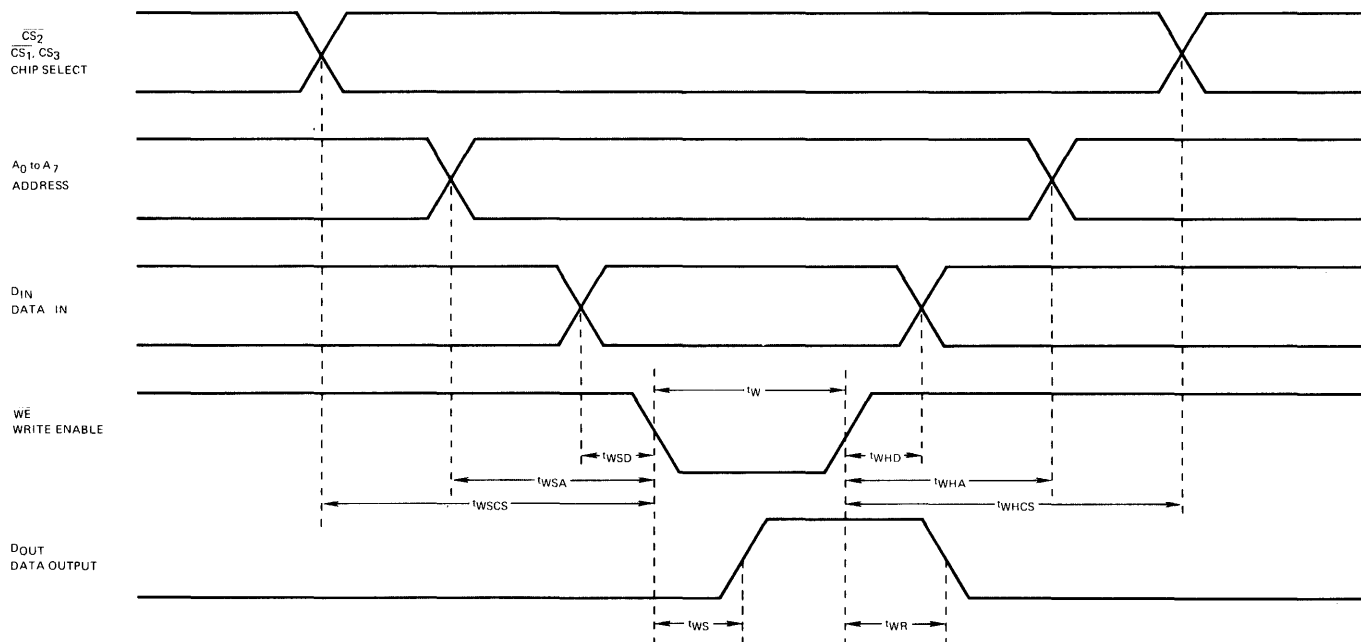

TYPICAL ELECTRICAL CHARACTERISTICS

OUTPUT CURRENT VERSUS OUTPUT VOLTAGE (OUTPUT HIGH)

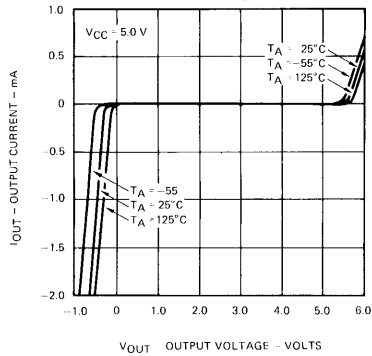

OUTPUT CURRENT VERSUS OUTPUT VOLTAGE (OUTPUT LOW)

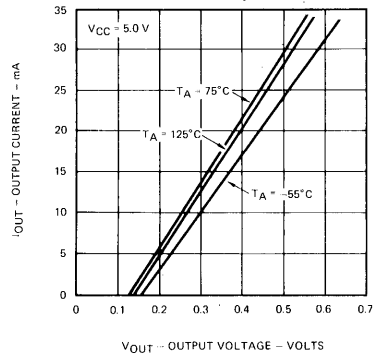

POWER SUPPLY CURRENT VERSUS TEMPERATURE

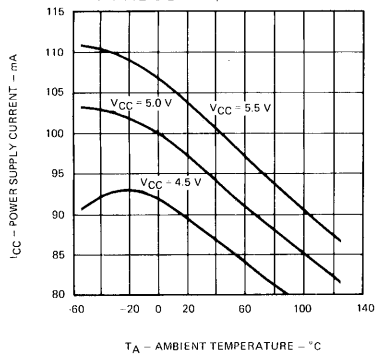

NORMALIZED ADDRESS ACCESS TIME VERSUS LOAD CAPACITANCE

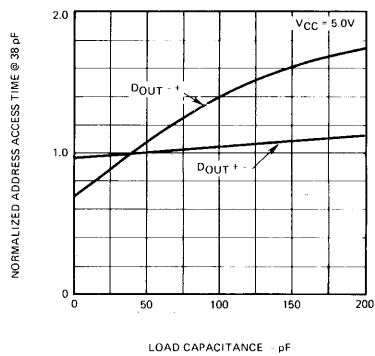

INPUT CURRENT VERSUS INPUT VOLTAGE VERSUS TEMPERATURE

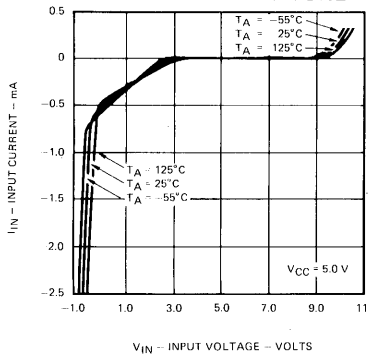

INPUT CURRENT VERSUS INPUT VOLTAGE VERSUS SUPPLY VOLTAGE

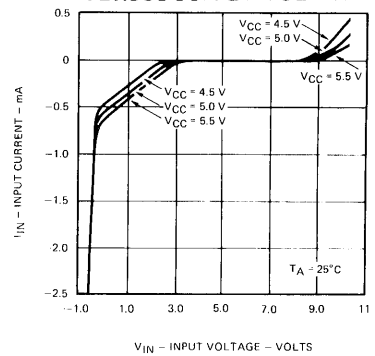

TTL ISOPLANAR MEMORY 93415

1024-BIT FULLY DECODED RANDOM ACCESS MEMORY

DESCRIPTION — The 93415 is a 1024-Bit Read/Write Random Access Memory organized 1024 words x 1-bit. It has a typical access time of 60 ns and is designed for buffer and control storage and high performance main memory applications.

The 93415 includes full decoding on the chip, has separate data input and data output lines and an active LOW chip select line.

The device is fully compatible with standard DTL and TTL logic families and has an uncommitted collector output for ease of memory expansion.

- NON-INVERTING DATA OUTPUTS
- ORGANIZED 1024 WORDS X 1-BIT
- READ ACCESS TIME 60 ns TYP.
- CHIP SELECT ACCESS TIME 30 ns TYP.
- POWER DISSIPATION 0.5 mW/BIT TYP.
- INPUT LOADING 0.25 TTL UNIT LOADS
- UNCOMMITTED COLLECTOR OUTPUT
- POWER DISSIPATION DECREASES WITH INCREASING TEMPERATURE
- TTL COMPATIBLE

PIN NAMES

\overline{CS}	Chip Select
A ₀ to A ₉	Address Inputs
\overline{WE}	Write Enable
D _{IN}	Data Input
D _{OUT}	Data Output

LOADING

0.25 U.L.
0.25 U.L.
0.25 U.L.
0.25 U.L.
10 U.L.

1 Unit Load (U.L.) = 40 μ A HIGH/1.6 mA LOW

LOGIC SYMBOL

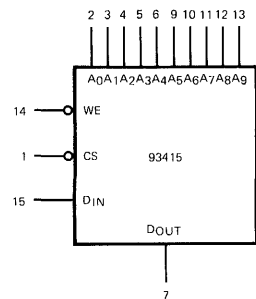

V_{CC} = PIN 16
GND = PIN 8

CONNECTION DIAGRAM DIP (TOP VIEW)

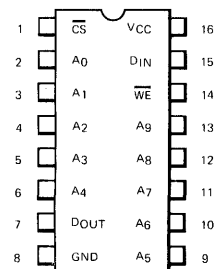

LOGIC DIAGRAM

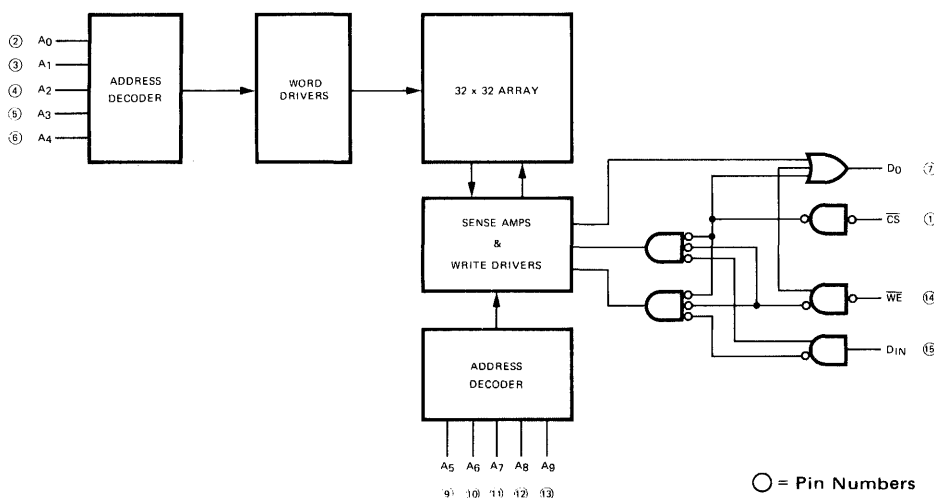

FAIRCHILD ISOPLANAR TTL MEMORY • 93415

FUNCTIONAL DESCRIPTION — The 93415 is a fully decoded 1024-bit Random Access Memory organized 1024 words by 1-bit. Bit selection is achieved by means of a 10-bit address A₀ to A₉.

One chip select input is provided for memory array expansion with the need for one additional external decoder. For larger memories the fast chip select access time permits the decoding of chip select, \overline{CS} , from the address without affecting system performance.

The read and write operations are controlled by the state of the active LOW Write Enable \overline{WE} (pin 14). With \overline{WE} held LOW and the chip selected, the data at D_{IN} is written into the addressed location. To read, \overline{WE} is held HIGH and the chip selected. Data in the specified location is presented at D_{OUT} and is non-inverted.

Uncommitted collector outputs are provided on the 93415 to allow maximum flexibility in output connection. In many applications such as memory expansion, the outputs of many 93415 can be tied together. In other applications the wired-OR is not used. In either case an external pull up resistor of value R_L must be used to provide a HIGH at the output when it is off. Any value of R_L within the range specified below may be used.

$$\frac{V_{CC}(\text{min})}{I_{OL} - \text{F.O. (1.6)}} \leq R_L \leq \frac{V_{CC}(\text{min}) - V_{OH}}{N(I_{CEX}) + \text{F.O. (0.04)}}$$

R_L is in kΩ
 N = number of wired-OR outputs tied together
 F.O. = number of TTL Unit Loads (U.L.) driven
 I_{CEX} = Memory Output Leakage Current
 V_{OH} = Required Output HIGH Level at Output Node
 I_{OL} = Output LOW Current

The minimum value of R_L is limited by output current sinking ability. The maximum value of R_L is determined by the output and input leakage current which must be supplied to hold the output at V_{OH}.

TABLE I — TRUTH TABLE

INPUTS			OUTPUT	MODE
\overline{CS}	\overline{WE}	DI	Open Collector	
H	X	X	H	NOT SELECTED
L	L	L	H	WRITE "0"
L	L	H	H	WRITE "1"
L	H	X	D ₀	READ

H = HIGH Voltage
 L = LOW Voltage
 X = Don't Care (HIGH or LOW)

TYPICAL INPUT AND OUTPUT CHARACTERISTICS

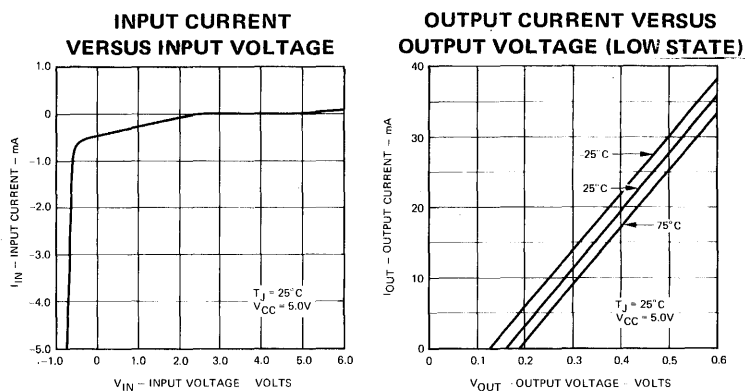

ABSOLUTE MAXIMUM RATINGS (above which the useful life may be impaired)

Storage Temperature	-65°C to +150°C
Temperature (Ambient) Under Bias	0°C to +75°C
V _{CC} Pin Potential to Ground Pin	-0.5V to +7.0V
*Input Voltage (dc)	-0.5V to +5.5V
*Input Current (dc)	-12 mA to +5.0 mA
Voltage Applied to Outputs (Output HIGH)	0.5 V to +4.50V
Output Current (dc) (Output LOW)	+20 mA

*Either input voltage or input current limit is sufficient to protect the input.

GUARANTEED OPERATING RANGES

PART NUMBER	SUPPLY VOLTAGE (V _{CC})			AMBIENT TEMPERATURE (Note 4)
	.MIN.	TYP.	MAX.	
93415XC	4.75 V	5.0 V	5.25 V	0°C to 75°C

X = package type; F for Flatpak, D for Ceramic Dip, P for Plastic Dip. See Packaging Information Section for packages available on this product.

FAIRCHILD ISOPLANAR TTL MEMORY • 93415

TO BE ANNOUNCED

ELECTRICAL CHARACTERISTICS OVER OPERATING TEMPERATURE RANGE (unless otherwise noted)

SYMBOL	CHARACTERISTIC	LIMITS			UNITS	CONDITIONS
		MIN.	TYP. (Note 3)	MAX.		
VOL	Output LOW Voltage		0.3	0.45	Volts	V _{CC} = MIN., I _{OL} = 16 mA
VIH	Input HIGH Voltage	2.1	1.6		Volts	Guaranteed Input HIGH Voltage for all Inputs
VIL	Input LOW Voltage		1.5	0.8	Volts	Guaranteed Input LOW Voltage for all Inputs
IIL	Input LOW Current		-250	-400	μA	V _{CC} = MAX., V _{IN} = 0.4 V
IIH	Input HIGH Current		1.0	20	μA	V _{CC} = MAX., V _{IN} = 4.5 V
				1.0	mA	V _{CC} = MAX., V _{IN} = 5.25 V
ICEX	Output Leakage Current		1.0	50	μA	V _{CC} = MAX., V _{OUT} = 4.5 V
VCD	Input Diode Clamp Voltage		-1.0	-1.5	Volts	V _{CC} = MAX., I _{IN} = -10 mA
ICC	Power Supply Current		90	130	mA	T _A ≥ 25°C
			110	150	mA	T _A < 25°C

NOTES:

- Conditions for testing, not shown in the Table, are chosen to guarantee operation under "worst case" conditions.
- The specified LIMITS represents the "worst case" value for the parameters. Since these "worst case" values normally occur at the temperature and supply voltage extremes, additional noise immunity and guard banding can be achieved by decreasing the allowable system operating ranges.
- Typical limits are at V_{CC} = 5.0 V, 25°C, and max. loading.
- The Operating Ambient Temperature Ranges are guaranteed with transverse air flow exceeding 400 linear feet per minute and a two minute warm-up. Typical thermal resistance values of the package are:
 θ_{JA} (Junction to Ambient) = 50°C/Watt (at 400 fpm air flow)
 θ_{JA} (Junction to Ambient) = 90°C/Watt (still air)
 θ_{JC} (Junction to Case) = 25°C/Watt
 The 100°C Operating Temperature relates to a "worst case" junction temperature of 125°C.
- The maximum address access time is guaranteed to be the "worst case" bit in the memory using a pseudo random testing pattern.

SWITCHING CHARACTERISTICS – OVER OPERATING TEMPERATURE AND VOLTAGE RANGES

SYMBOL	CHARACTERISTIC	MIN.	TYP.	MAX.	UNITS	CONDITIONS
READ MODE	DELAY TIMES					
t _{ACS}	Chip Select Access Time		30	55		See Test Circuit and Waveforms on page 9-30 (Note 5)
t _{RCS}	Chip Select Recovery Time		30	55	ns	
t _{AA}	Address Access Time		60	90		
WRITE MODE	DELAY TIMES					
t _{WS}	Write Disable Time		35	45	ns	See Test Circuit and Waveforms on page 9-30
t _{WR}	Write Recovery Time		45	65		
	INPUT TIMING REQUIREMENTS					
t _W	Minimum Write Pulse Width		30	55		
t _{WSD}	Data Set-Up Time Prior to Write		0	5		
t _{WHD}	Data Hold Time After Write		0	5		
t _{WSA}	Address Set-Up Time		20	35	ns	
t _{WHA}	Address Hold Time		0	5		
t _{WSCS}	Chip Select Set-Up Time		0	5		
t _{WHCS}	Chip Select Hold Time		0	5		
C _{IN}	Input Pin Capacitance		4	5	pF	
C _{OUT}	Output Pin Capacitance		7	8		

TTL MEMORY 93434

256-BIT READ-ONLY MEMORY

FORMERLY 9034

DESCRIPTION – The Fairchild 93434 is a 256-Bit bipolar TTL Read-Only Memory. The memory is organized as 32 words of eight bits each. The words are selected through five address lines. The eight outputs of the words are uncommitted collectors which may be wired-OR with the outputs of other ROMs. An Enable input is provided for additional decoding flexibility. A HIGH on the Enable input forces all outputs to be HIGH.

The contents of the memory are permanently programmed to customer order. A customer order form is available on request.

- TTL COMPATIBLE
- OUTPUT WIRED-OR CAPABILITY
- SINGLE TTL LOAD INPUTS
- INPUT CLAMP DIODES

ABSOLUTE MAXIMUM RATINGS

Storage Temperature	-65°C to +150°C
Temperature (Ambient) Under Bias	-55°C to +125°C
V _{CC} Pin Potential to Ground	-0.5V to +8.0V
Input Pin Voltage	-1.5V to 5.5V
Current Into Output Terminal	100 mA
Output Voltages	-0.5 V to V _{CC} Value

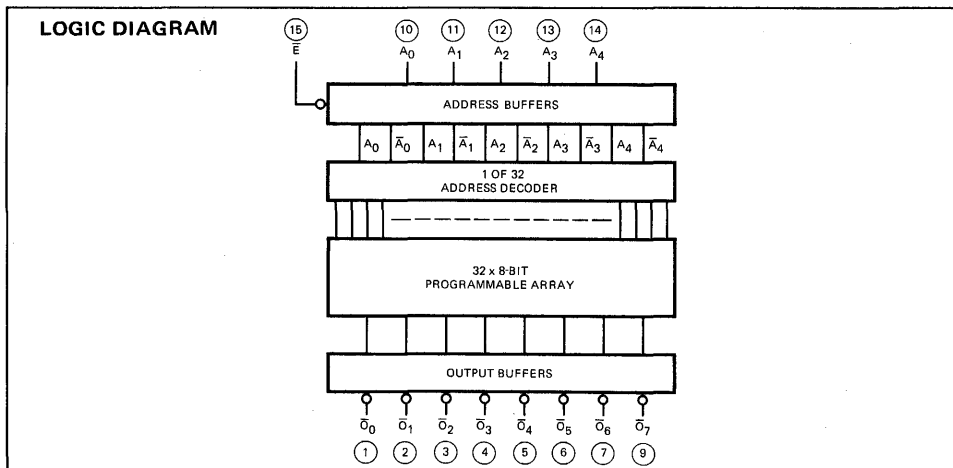

LOGIC SYMBOL

V_{CC} = PIN 16
GND = PIN 8

CONNECTION DIAGRAMS
DIP (TOP VIEW)

FLATPAK (TOP VIEW)

FAIRCHILD TTL MEMORY • 93434

ELECTRICAL CHARACTERISTICS ($T_A = -55^\circ\text{C}$ to $+125^\circ\text{C}$, $V_{CC} = 5.0\text{ V} \pm 10\%$) (units are pulse tested) (Part No. 93434XM)*

SYMBOL	PARAMETER	LIMITS			UNITS	TEST CONDITIONS
		-55°C MIN. MAX.	+25°C MIN. MAX.	+125°C MIN. MAX.		
I _{FA}	Address Input Load Current	-1.6	-1.6	-1.6	mA	V _{CC} = 5.5 V V _A = 0.4 V
I _{FE}	Enable Input Load Current	-1.6	-1.6	-1.6	mA	V _{CC} = 5.5 V V _E = 0.4 V
I _{RA}	Address Input Leakage Current	100	100	100	μA	V _{CC} = 5.5 V V _A = 4.5 V
I _{RE}	Enable Input Leakage Current	100	100	100	μA	V _{CC} = 5.5 V V _E = 4.5 V
I _{CEX}	Output Leakage Current	200	200	200	μA	V _{CC} = 5.5 V V _{CEX} = 5.5 V Enable input to 2.0V
V _{OL}	Output LOW Voltage	0.4	0.4	0.4	V	V _{CC} = 4.5 V I _{OUT} = 10 mA The word containing a "0" bit is selected when performing this test.
V _{IL}	Input LOW Voltage	0.8	0.9	0.8	V	V _{CC} = 5.5 V Enable input grounded. Monitor appropriate output to guarantee this test.
V _{IH}	Input HIGH Voltage	2.0	1.7	1.4	V	V _{CC} = 4.5 V Enable input grounded. Monitor appropriate output to guarantee this test.
I _{CC}	Power Supply Current	80	80	80	mA	V _{CC} = 5.5 V All inputs grounded

ELECTRICAL CHARACTERISTICS ($T_A = 0^\circ\text{C}$ to $+75^\circ\text{C}$, $V_{CC} = 5.0\text{ V} \pm 5\%$) (units are pulse tested) (Part No. 93434XC)*

SYMBOL	PARAMETER	LIMITS			UNITS	TEST CONDITIONS
		0°C MIN. MAX.	+25°C MIN. MAX.	+75°C MIN. MAX.		
I _{FA}	Address Input Load Current	-1.6	-1.6	-1.6	mA	V _{CC} = 5.25 V V _A = 0.45 V
I _{FE}	Enable Input Load Current	-1.6	-1.6	-1.6	mA	V _{CC} = 5.25 V V _E = 0.45 V
I _{RA}	Address Input Leakage Current	100	100	100	μA	V _{CC} = 5.25 V V _A = 4.5 V
I _{RE}	Enable Input Leakage Current	100	100	100	μA	V _{CC} = 5.25 V V _E = 4.5 V
I _{CEX}	Output Leakage Current	200	200	200	μA	V _{CC} = 5.25 V V _{CEX} = 5.25 V Enable input to 2.0 V
V _{OL}	Output LOW Voltage	0.45	0.45	0.45	V	V _{CC} = 4.75 V I _{OUT} = 10 mA The word containing a "0" bit is selected when performing this test.
V _{IL}	Input LOW Voltage	0.85	0.85	0.85	V	V _{CC} = 5.25 V Enable input grounded. Monitor appropriate output to guarantee this test.
V _{IH}	Input HIGH Voltage	1.9	1.8	1.6	V	V _{CC} = 4.75 V Enable input grounded. Monitor appropriate output to guarantee this test.
I _{CC}	Power Supply Current	80	80	80	mA	V _{CC} = 5.25 V All inputs grounded

*X=package type; F for Flatpak, D for Ceramic Dip, P for Plastic Dip. See Packaging Information Section for packages available on this product.

SWITCHING TIME CHARACTERISTICS ($T_A = 25^\circ\text{C}$)

SYMBOL	PARAMETER	LIMITS		UNITS	TEST CONDITIONS
		MIN.	TYP. MAX.		
t ₊₊	Enable and Address Delay	*	50	ns	10 mA load. See Note 1.
t ₋₋	Enable and Address Delay	*	50	ns	10 mA load. See Note 1.
t ₊₋	Address Delay	*	50	ns	10 mA load. See Note 2.
t ₋₊	Address Delay	*	50	ns	10 mA load. See Note 2.

*See Typical Electrical Characteristics curves.

NOTES:

- (1) To test Enable delay, apply input pulse to Enable input. The word selected must contain a "0" in the bit under test.

To test Address delay, the enable input must be low. Apply the input pulse to the Address input under test. The words selected must contain a "1" when input pulse is low and a "0" when input pulse is high in the bit under test.
- (2) To test Address delay, the Enable input must be low. Apply the input pulse to the Address input under test. The words selected must contain a "0" when input pulse is low and a "1" when input pulse is high in the bit under test.

SWITCHING TIME TEST CONDITIONS AND WAVEFORMS

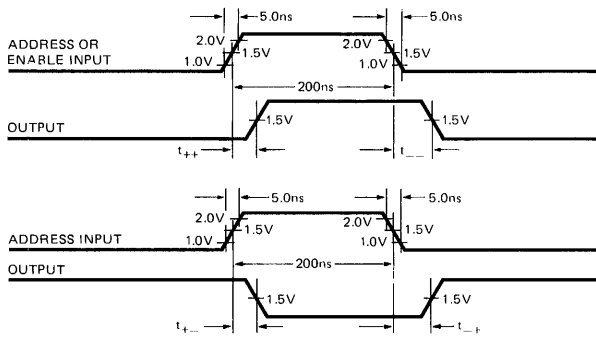

SWITCHING TEST OUTPUT LOAD

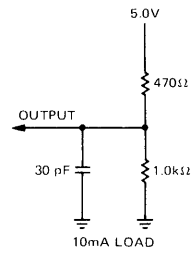

LOADING RULES

TTL INPUT LOAD AND DRIVE FACTORS

INPUTS	LOADING	OUTPUTS	DRIVE FACTOR
LOW Level	1.7 U.L.	All outputs	Open Collector 6.25 U.L.
HIGH Level	1.0 U.L.		

1 LOW Level TTL Unit Load (U.L.) = 1.6 mA
1 HIGH Level TTL Unit Load (U.L.) = 60 μA

TYPICAL ELECTRICAL CHARACTERISTICS

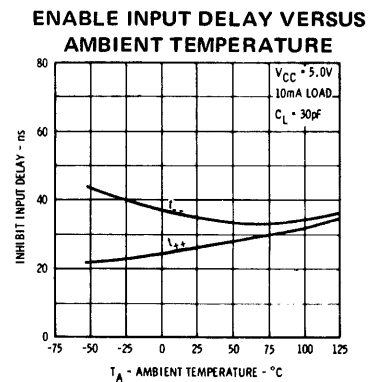
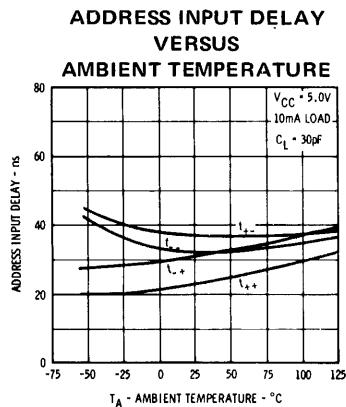
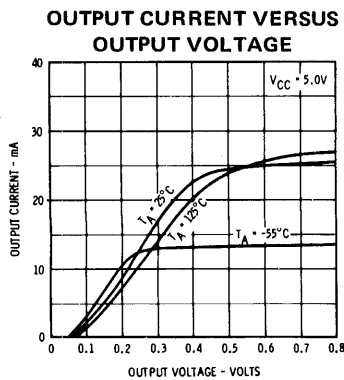
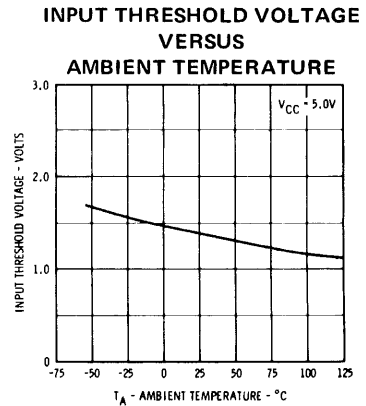
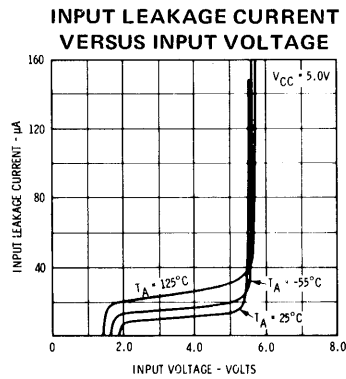
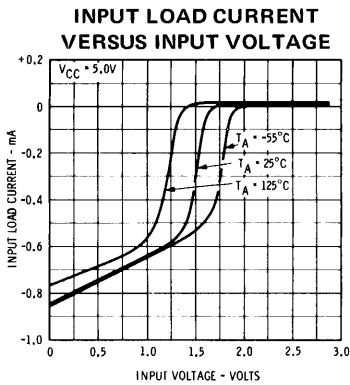

TTL MEMORY 93435

64-BIT LINEAR SELECT READ/WRITE MEMORY

FORMERLY 9035

DESCRIPTION – The 93435 is a high speed 64-Bit Read/Write Memory Cell designed for use in high speed scratch pad memories. It is a linear select 16 word by 4-bit array.

The 93435 is available in the hermetically sealed 36-lead ceramic Dual In-Line package and will operate over the temperature range from -55°C to $+125^{\circ}\text{C}$.

OPERATION – In addition to 16 address inputs, 4 data outputs, and 4 data inputs, the 93435 has a chip select and a write enable. When the chip select is HIGH, a word may be addressed by a HIGH on one of the address inputs. Data is written into the addressed word location only when the write enable is held LOW. While the address is present, the outputs continuously show the contents of the word selected. Readout is non-destructive.

Up to four words may be addressed and read simultaneously with the OR function of each bit appearing at the outputs. Data can be written into two locations simultaneously.

Uncommitted collector outputs are provided on the 93435 to allow maximum flexibility in output connection. In many applications such as memory expansion, the outputs of many 93435's can be tied together. In other applications the wired-OR is not used. In either case an external pullup resistor of value R must be used to provide a HIGH at the output when it is off. Any value of R within the range specified below may be used.

$$\frac{5.1}{10 - \text{F.O. (1.6)}} \leq R \leq \frac{2.1}{N(0.1) + \text{F.O. (0.06)}}$$

R is in $k\Omega$
N = number of wired-OR outputs
F.O. = number of TTL loads driven

The minimum value of R is limited by output current sinking ability. The maximum value of R is determined by the output and input leakage current (I_{CEX} and I_{R}) which must be supplied to hold the output at 2.4 V.

- 35 ns MAXIMUM ACCESS TIME – 20 ns TYPICAL
- CHIP SELECT AND WRITE ENABLES
- UNCOMMITTED COLLECTOR OUTPUTS FOR WIRED-OR CAPABILITY
- LINEAR SELECT
- ON CHIP ADDRESS LINE BUFFERING
- TTL COMPATIBLE

ABSOLUTE MAXIMUM RATINGS

Storage Temperature	-65°C to $+150^{\circ}\text{C}$
Temperature (Ambient) Under Bias	-55°C to $+125^{\circ}\text{C}$
V_{CC} Pin Potential to Ground	-0.5 V to $+7.0\text{ V}$
Input Pin Voltage	-0.5 V to $+5.5\text{ V}$
Current into Output Terminal	50 mA
Output Voltage	-0.5 V to $+8.0\text{ V}$

LOGIC SYMBOL

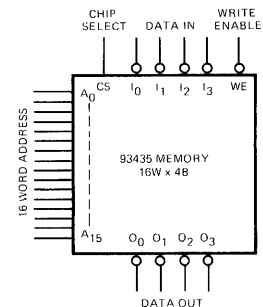

CONNECTION DIAGRAM DIP (TOP VIEW)

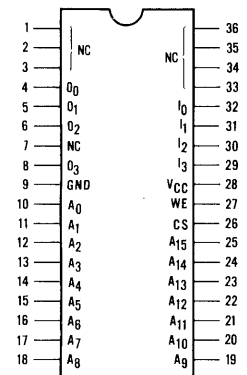

NC = No Internal Connection

FAIRCHILD TTL MEMORY • 93435

LOADING RULES

	HIGH LEVEL (TTL Unit Loads)	LOW LEVEL (TTL Unit Loads)
Address	1.67	1
Chip Select	26.7	1 (see note 1)
Write Enable	1.67	1
Data Input	3.34	2
Data Output	Open Collector	6.2

1 LOW Level TTL Unit Load = 1.6 mA
1 HIGH Level TTL Unit Load = 60 μ A

ELECTRICAL CHARACTERISTICS ($T_A = -55^\circ\text{C}$ to 125°C , $V_{CC} = 5.0\text{ V} \pm 10\%$) (units are pulse tested) (Part No. 93435XM)*

SYMBOL	PARAMETER	LIMITS			UNITS	CONDITIONS
		-55°C MIN. MAX.	$+25^\circ\text{C}$ MIN. MAX.	$+125^\circ\text{C}$ MIN. MAX.		
I _{FA}	Address Input Load Current	-1.6	-1.6	-1.6	mA	$V_{CC} = 5.5\text{ V}$, $V_A = 0.4\text{ V}$
I _{FCS}	Chip Select Load Current	-1.6	-1.6	-1.6	mA	$V_{CC} = 5.5\text{ V}$, $V_{CS} = 0.4\text{ V}$ See Note 1
I _{FWE}	Write Enable Load Current	-1.6	-1.6	-1.6	mA	$V_{CC} = 5.5\text{ V}$, $V_W = 0.4\text{ V}$
I _{FD}	Data Input Load Current	-3.2	-3.2	-3.2	mA	$V_{CC} = 5.5\text{ V}$, $V_D = 0.4\text{ V}$
I _{RA}	Address Input Leakage Current	100	100	100	μ A	$V_{CC} = 5.5\text{ V}$, $V_A = 4.5\text{ V}$
I _{RCS}	Chip Select Input Leakage Current	1.6	1.6	1.6	mA	$V_{CC} = 5.5\text{ V}$, $V_{CS} = 4.5\text{ V}$
I _{RWE}	Write Enable Leakage Current	100	100	100	μ A	$V_{CC} = 5.5\text{ V}$, $V_W = 4.5\text{ V}$
I _{RD}	Data Input Leakage Current	200	200	200	μ A	$V_{CC} = 5.5\text{ V}$, $V_D = 4.5\text{ V}$
I _{CEX}	Output Leakage Current	100	100	100	μ A	$V_{CC} = 5.5\text{ V}$, $V_{CEX} = 5.5\text{ V}$ Write Enable Input Grounded
V _{OL}	Output LOW Voltage	0.4	0.4	0.4	Volts	$V_{CC} = 4.5\text{ V}$, $I_{OL} = 10\text{ mA}$ One Word Addressed
V _{IL}	Input LOW Voltage	0.8	0.9	0.8	Volts	$V_{CC} = 5.0\text{ V}$, Monitor Appropriate Output To Guarantee This Test Limit
V _{IH}	Input HIGH Voltage	2.1	2.0	2.0	Volts	$V_{CC} = 5.0\text{ V}$, Monitor Appropriate Output To Guarantee This Test Limit
I _{PD}	Supply Current	118	118	118	mA	$V_{CC} = 5.5\text{ V}$, One Word Addressed

ELECTRICAL CHARACTERISTICS ($T_A = 0^\circ\text{C}$ to 75°C , $V_{CC} = 5.0\text{ V} \pm 5\%$) (units are pulse tested) (Part No. 93435XC)*

SYMBOL	PARAMETER	LIMITS			UNITS	CONDITIONS
		0°C MIN. MAX.	$+25^\circ\text{C}$ MIN. MAX.	$+75^\circ\text{C}$ MIN. MAX.		
I _{FA}	Address Input Load Current	-1.6	-1.6	-1.6	mA	$V_{CC} = 5.25\text{ V}$, $V_A = 0.45\text{ V}$
I _{FCS}	Chip Select Load Current	-1.6	-1.6	-1.6	mA	$V_{CC} = 5.25\text{ V}$, $V_{CS} = 0.45\text{ V}$ See Note 1
I _{FWE}	Write Enable Load Current	-1.6	-1.6	-1.6	mA	$V_{CC} = 5.25\text{ V}$, $V_W = 0.45\text{ V}$
I _{FD}	Data Input Load Current	-3.2	-3.2	-3.2	mA	$V_{CC} = 5.25\text{ V}$, $V_D = 0.45\text{ V}$
I _{RA}	Address Input Leakage Current	100	100	100	μ A	$V_{CC} = 5.25\text{ V}$, $V_A = 4.5\text{ V}$
I _{RCS}	Chip Select Input Leakage Current	1.6	1.6	1.6	mA	$V_{CC} = 5.25\text{ V}$, $V_{CS} = 4.5\text{ V}$
I _{RWE}	Write Enable Leakage Current	100	100	100	μ A	$V_{CC} = 5.25\text{ V}$, $V_W = 4.5\text{ V}$
I _{RD}	Data Input Leakage Current	200	200	200	μ A	$V_{CC} = 5.25\text{ V}$, $V_D = 4.5\text{ V}$
I _{CEX}	Output Leakage Current	100	100	100	μ A	$V_{CC} = 5.25\text{ V}$, $V_{CEX} = 5.25\text{ V}$ Write Enable Input Grounded
V _{OL}	Output LOW Voltage	0.45	0.45	0.45	Volts	$V_{CC} = 4.75\text{ V}$, $I_{OL} = 10\text{ mA}$ One Word Addressed
V _{IL}	Input LOW Voltage	0.85	0.85	0.85	Volts	$V_{CC} = 5.0\text{ V}$, Monitor Appropriate Output To Guarantee This Test Limit
V _{IH}	Input HIGH Voltage	2.0	2.0	2.0	Volts	$V_{CC} = 5.0\text{ V}$, Monitor Appropriate Output To Guarantee This Test Limit
I _{PD}	Supply Current	124	124	124	mA	$V_{CC} = 5.25\text{ V}$, One Word Addressed

*X = package type; F for Flatpak, D for Ceramic Dip, P for Plastic Dip. See Packaging Information Section for packages available on this product.
NOTE:

(1) I_{FCS} increases by 1.6 mA for each address input held at a logic 1.

TYPICAL ELECTRICAL CHARACTERISTICS

ADDRESS INPUT LOAD CURRENT VERSUS INPUT VOLTAGE

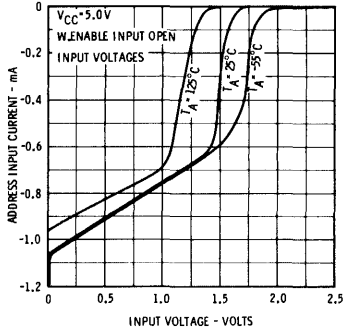

ADDRESS INPUT LEAKAGE CURRENT VERSUS INPUT VOLTAGE

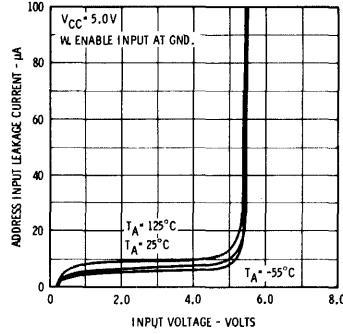

OUTPUT CURRENT VERSUS OUTPUT SATURATION VOLTAGE

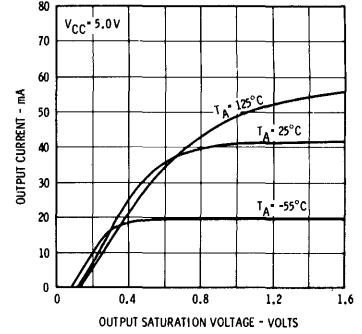

ADDRESS TO OUTPUT DELAY TIME VERSUS OUTPUT LOAD CAPACITANCE

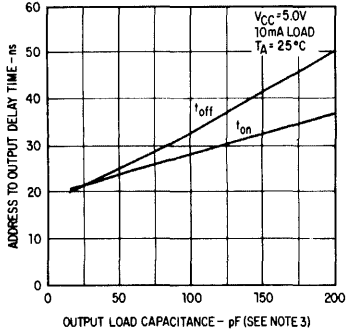

ADDRESS TO OUTPUT DELAY TIME VERSUS TEMPERATURE

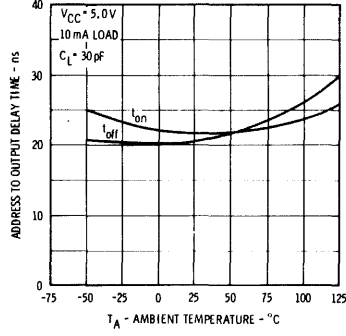

WRITE PULSE WIDTH VERSUS TEMPERATURE

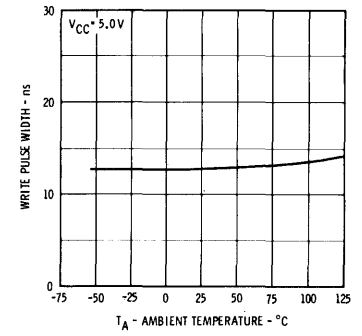

SWITCHING CHARACTERISTICS (T_A = 25°C, V_{CC} = 5.0 V)

SYMBOL	PARAMETER	LIMIT (ns)			CONDITION		
		MIN.	TYP.	MAX.	LOAD	C	NOTE
t _{on}	Address to Output Turn-On Delay	10	22	35	10 mA	30 pF	1
t _{off}	Address to Output Turn-Off Delay	10	20	35	10 mA	30 pF	1
t _{WP}	Write Pulse Width Required to Write	25	15		10 mA	30 pF	2
t _{WD}	Write Delay	10	30	50	10 mA	30 pF	2

NOTES:

- To test t_{on} and t_{off}, a LOW must be stored in the cell under test.
- One word is selected during the test.
- The typical capacitance of one 93435 output is 7.0 pF.

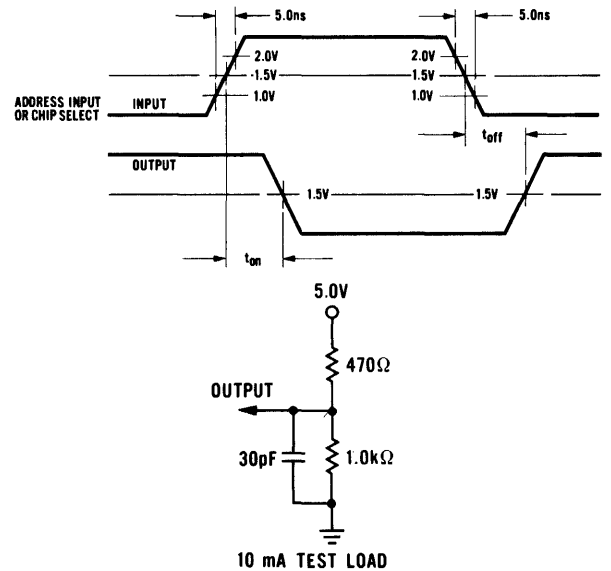
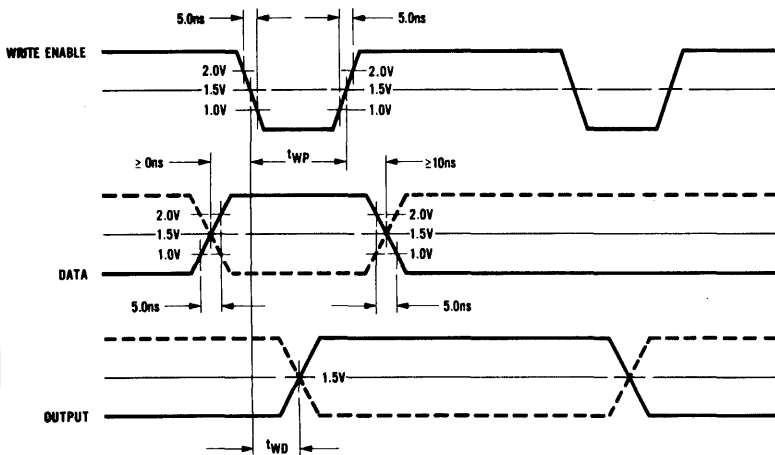

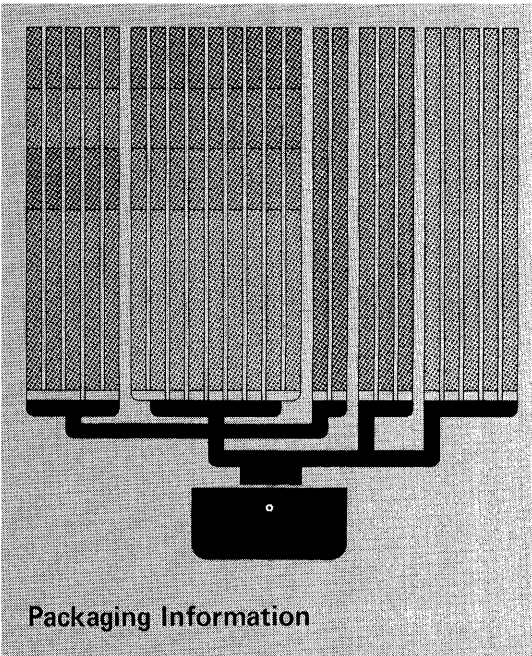

PACKAGING INFORMATION

Fairchild digital integrated circuits may be ordered using a simplified purchasing code in which the package style is defined as follows:

PACKAGE STYLE

- D = Dual In-Line – Ceramic (Hermetic)
- P = Dual In-Line – Plastic
- F = Flat Package

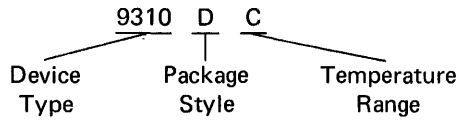

In order to accommodate varying die sizes (SSI, MSI, etc), numbers of pins (14, 16, 24, etc.), and package outlines, a number of different package forms are required in each of these three categories.

The following lists indicate the specific package dimensions currently used for each device type. The detailed outline corresponding to each package code is shown at the end of this section.

DEVICE	MILITARY (M) -55° to +125° C		DEVICE	COMMERCIAL (C)/INDUSTRIAL 0° to +70°/75° C		
	CERAMIC DIP (D)	FLATPAK (F)		CERAMIC DIP (D)	PLASTIC DIP (P)	FLATPAK (F)
4100 (see 93400)						
4101 (see 93401)						
4102 (see 93402)						
4103 (see 93403)						
4106 (see 93406)						
5033 (see 93407)						
5400	6A	3I	7400	6A	9A	3I
5401	6A	3I	7401	6A	9A	3I
5402	6A	3I	7402	6A	9A	3I
5403	6A	3I	7403	6A	9A	3I
5404	6A	3I	7404	6A	9A	3I
5405	6A	3I	7405	6A	9A	3I
5406	6A	3I	7406	6A	9A	3I
5407	6A	3I	7407	6A	9A	3I
5408	6A	3I	7408	6A	9A	3I
5409	6A	3I	7409	6A	9A	3I
5410	6A	3I	7410	6A	9A	3I
5411	6A	3I	7411	6A	9A	3I
5412	6A	3I	7412	6A	9A	3I
5413	6A	3I	7413	6A	9A	3I
5416	6A	3I	7416	6A	9A	3I
5417	6A	3I	7417	6A	9A	3I
5420	6A	3I	7420	6A	9A	3I
5423	6B	4L	7423	6B	9B	4L
5425	6A	3I	7425	6A	9A	3I
5426	6A		7426	6A	9A	3I
5427	6A	3I	7427	6A	9A	3I
5430	6A	3I	7430	6A	9A	3I
5432	6A	3I	7432	6A	9A	3I
5437	6A	3I	7437	6A	9A	3I
5438	6A	3I	7438	6A	9A	3I
5439	6A	3I	7439	6A	9A	3I
5440	6A	3I	7440	6A	9A	3I
			7441	6B	9B	4L
5442	6B	4L	7442	6B	9B	4L
5443	6B	4L	7443	6B	9B	4L
5444	6B	4L	7444	6B	9B	4L

PACKAGING INFORMATION

DEVICE	MILITARY (M) -55° to +125° C		DEVICE	COMMERCIAL (C)/INDUSTRIAL 0° to +70°/75° C		
	CERAMIC DIP (D)	FLATPAK (F)		CERAMIC DIP (D)	PLASTIC DIP (P)	FLATPAK (F)
5445	7B	4L	7445	7B	9B	4L
5446	7B	4L	7446	7B	9B	4L
5447	7B	4L	7447	7B	9B	4L
5448	7B	4L	7448	7B	9B	4L
5449		3I	7449			3I
5450	6A	3I	7450	6A	9A	3I
5451	6A	3I	7451	6A	9A	3I
5453	6A	3I	7453	6A	9A	3I
5454	6A	3I	7454	6A	9A	3I
5460	6A	3I	7460	6A	9A	3I
5470	6A	3I	7470	6A	9A	3I
5472	6A	3I	7472	6A	9A	3I
5473	6A	3I	7473	6A	9A	3I
5474	6A	3I	7474	6A	9A	3I
5475	6B	4L	7475	6B	9B	4L
5476	6B	4L	7476	6B	9B	4L
5477		3I	7477			3I
5480	6A	3I	7480	6A	9A	3I
5482	6A	3I	7482	6A	9A	3I
5483	6B	4L	7483	6B	9B	4L
5486	6A	3I	7486	6A	9A	3I
5490	6A	3I	7490	6A	9A	3I
5491	6A	3I	7491	6A	9A	3I
5492	6A	3I	7492	6A	9A	3I
5493	6A	3I	7493	6A	9A	3I
5494	6B	4L	7494	6B	9B	4L
5495	6A	3B	7495	6A	9A	3B
5496	7B	4L	7496	7B	9B	4L
54104	6A	3I	74104	6A	9A	3I
54105	6A	3I	74105	6A	9A	3I
54107	6A		74107	6A	9A	
54121	6A	3I	74121	6A	9A	3I
			74141	6B	9B	
54145	7B	4L	74145	7B	9B	4L
54150	6N	4M	74150	6N		4M
54151	7B	4L	74151	7B	9B	4L
54152	7A	3B	74152	7A	9A	3B
54153	7B	4L	74153	7B	9B	4L
54164	7A	3B	74164	7A	9A	3B
54165	7B	4L	74165	7B	9B	4L
54180	7A	3B	74180	7A	9A	3B
54181	6N	4M	74181	6N		4M
54182	7B	4L	74182	7B	9B	4L
54190	7B	4L	74190	7B	9B	4L
54191	7B	4L	74191	7B	9B	4L
54192	7B	4L	74192	7B	9B	4L
54193	7B	4L	74193	7B	9B	4L
54196	7A	3B	74196	7A	9A	3B
54197	7A	3B	74197	7A	9A	3B
54198	6N	4M	74198	6N		4M
54H00	6A	3I	74H00	6A	9A	3I

PACKAGING INFORMATION

DEVICE	MILITARY (M) -55° to +125°C		DEVICE	COMMERCIAL (C)/INDUSTRIAL 0° to +70°/75°C		
	CERAMIC DIP (D)	FLATPAK (F)		CERAMIC DIP (D)	PLASTIC DIP (P)	FLATPAK (F)
54H01	6A	3I	74H01	6A	9A	3I
54H04	6A	3I	74H04	6A	9A	3I
54H05	6A	3I	74H05	6A	9A	3I
54H08	6A	3I	74H08	6A	9A	3I
54H10	6A	3I	74H10	6A	9A	3I
54H11	6A	3I	74H11	6A	9A	3I
54H20	6A	3I	74H20	6A	9A	3I
54H21	6A	3I	74H21	6A	9A	3I
54H22	6A	3I	74H22	6A	9A	3I
54H30	6A	3I	74H30	6A	9A	3I
54H40	6A	3I	74H40	6A	9A	3I
54H50	6A	3I	74H50	6A	9A	3I
54H51	6A	3I	74H51	6A	9A	3I
54H52	6A	3I	74H52	6A	9A	3I
54H53	6A	3I	74H53	6A	9A	3I
54H54	6A	3I	74H54	6A	9A	3I
54H55	6A	3I	74H55	6A	9A	3I
54H60	6A	3I	74H60	6A	9A	3I
54H61	6A	3I	74H61	6A	9A	3I
54H62	6A	3I	74H62	6A	9A	3I
54H71	6A	3I	74H71	6A	9A	3I
54H72	6A	3I	74H72	6A	9A	3I
54H73	6A	3I	74H73	6A	9A	3I
54H74	6A	3I	74H74	6A	9A	3I
54H76	6B	4L	74H76	6B	9B	4L
54H78	6A	3I	74H78	6A	9A	3I
54H87	7A	3B	74H87	7A		3B
54H101	6A	3I	74H101	6A	9A	3I
54H102	6A	3I	74H102	6A	9A	3I
54H103	6A	3I	74H103	6A	9A	3I
54H106	6B	4L	74H106	6B	9B	4L
54H108	6A	3I	74H108	6A	9A	3I
54H183	7A	3B	74H183	7A		3B
54S00	6A	3I	74S00	6A		3I
54S03	6A	3I	74S03	6A		3I
54S04	6A	3I	74S04	6A		3I
54S05	6A	3I	74S05	6A		3I
54S20	6A	3I	74S20	6A		3I
54S22	6A	3I	74S22	6A		3I
54S40	6A	3I	74S40	6A		3I
54S64	6A	3I	74S64	6A		3I
54S65	6A	3I	74S65	6A		3I
54S74	6A	3I	74S74	6A		3I
54S112	6B	4L	74S112	6B		4L
54S113	6A	3I	74S113	6A		3I
54S114	6A	3I	74S114	6A		3I
54S140	6A	3I	74S140	6A		3I
55107	6A		75107	6A	9A	
55108	6A		75108	6A	9A	
55109	6A		75109	6A	9A	
55110			75110	6A	9A	
			7545C	6A		

10

PACKAGING INFORMATION

DEVICE	MILITARY (M) -55°C to +125°C		COMMERCIAL (C)/INDUSTRIAL 0°C to +70°C/75°C		
	CERAMIC DIP (D)	FLATPAK (F)	CERAMIC DIP (D)	PLASTIC DIP (P)	FLATPAK (F)
9000	6A	3I	6A		3I
9001	6A	3I	6A		3I
9002	6A	3I	6A		3I
9003	6A	3I	6A		3I
9004	6A	3I	6A		3I
9005	6A	3I	6A		3I
9006	6A	3I	6A		3I
9007	6A	3I	6A		3I
9008	6A	3I	6A		3I
9009	6A	3I	6A		3I
9012	6A	3I	6A		3I
9014	6B	4L	6B		4L
9015	6B	4L	6B		4L
9016	6A	3I	6A		3I
9017	6A	3I	6A		3I
9020	7B	4L	7B		4L
9022	7B	4L	7B		4L
9024	7B	4L	7B		4L
9033 (see 93433)					
9034 (see 93434)					
9035 (see 93435)					
9H00	6A	3I	6A	9A	3I
9H01	6A	3I	6A	9A	3I
9H04	6A	3I	6A	9A	3I
9H05	6A	3I	6A	9A	3I
9H08	6A	3I	6A	9A	3I
9H10	6A	3I	6A	9A	3I
9H11	6A	3I	6A	9A	3I
9H20	6A	3I	6A	9A	3I
9H21	6A	3I	6A	9A	3I
9H22	6A	3I	6A	9A	3I
9H30	6A	3I	6A	9A	3I
9H40	6A	3I	6A	9A	3I
9H50	6A	3I	6A	9A	3I
9H51	6A	3I	6A	9A	3I
9H52	6A	3I	6A	9A	3I
9H53	6A	3I	6A	9A	3I
9H54	6A	3I	6A	9A	3I
9H55	6A	3I	6A	9A	3I
9H60	6A	3I	6A	9A	3I
9H61	6A	3I	6A	9A	3I
9H62	6A	3I	6A	9A	3I
9H71	6A	3I	6A	9A	3I
9H72	6A	3I	6A	9A	3I
9H73	6A	3I	6A	9A	3I
9H74	6A	3I	6A	9A	3I
9H76	6B	4L	6B	9B	4L
9H78	6A	3I	6A	9A	3I
9H101	6A	3I	6A	9A	3I
9H102	6A	3I	6A	9A	3I
9H103	6A	3I	6A	9A	3I

PACKAGING INFORMATION

DEVICE	MILITARY (M) -55°C to +125°C		COMMERCIAL (C)/INDUSTRIAL 0°C to +70°C/75°C		
	CERAMIC DIP (D)	FLATPAK (F)	CERAMIC DIP (D)	PLASTIC DIP (P)	FLATPAK (F)
9H106	6B	4L	6B	9B	4L
9H108	6A	3I	6A	9A	3I
9L00	6A	3I	6A		3I
9L04	6A	3I	6A		3I
9L24	7B	4L	7B		4L
9L54	6A	3I	6A		3I
9L86	6A	3I	6A		3I
9N00	6A	3I	6A	9A	3I
9N01	6A	3I	6A	9A	3I
9N02	6A	3I	6A	9A	3I
9N03	6A	3I	6A	9A	3I
9N04	6A	3I	6A	9A	3I
9N05	6A	3I	6A	9A	3I
9N06	6A	3I	6A	9A	3I
9N07	6A	3I	6A	9A	3I
9N08	6A	3I	6A	9A	3I
9N09	6A	3I	6A	9A	3I
9N10	6A	3I	6A	9A	3I
9N11	6A	3I	6A	9A	3I
9N12	6A	3I	6A	9A	3I
9N13	6A	3I	6A	9A	3I
9N16	6A	3I	6A	9A	3I
9N17	6A	3I	6A	9A	3I
9N20	6A	3I	6A	9A	3I
9N23	6B	4L	6B	9B	4L
9N25	6A	3I	6A	9A	3I
9N26	6A	3I	6A	9A	3I
9N27	6A	3I	6A	9A	3I
9N30	6A	3I	6A	9A	3I
9N32	6A	3I	6A	9A	3I
9N37	6A	3I	6A	9A	3I
9N38	6A	3I	6A	9A	3I
9N39	6A	3I	6A	9A	3I
9N40	6A	3I	6A	9A	3I
9N50	6A	3I	6A	9A	3I
9N51	6A	3I	6A	9A	3I
9N53	6A	3I	6A	9A	3I
9N54	6A	3I	6A	9A	3I
9N60	6A	3I	6A	9A	3I
9N70	6A	3I	6A	9A	3I
9N72	6A	3I	6A	9A	3I
9N73	6A	3I	6A	9A	3I
9N74	6A	3I	6A	9A	3I
9N76	6B	4L	6B	9B	4L
9N86	6A	3I	6A	9A	3I
9N107	6A	3I	6A	9A	3I
9S00	6A	3I	6A		3I
9S03	6A	3I	6A		3I
9S04	6A	3I	6A		3I
9S04A	6A	3I	6A		3I
9S05	6A	3I	6A		3I
9S05A	6A	3I	6A		3I

10

PACKAGING INFORMATION

DEVICE	MILITARY (M) -55°C to +125°C		COMMERCIAL (C)/INDUSTRIAL 0°C to +70°C/75°C		
	CERAMIC DIP (D)	FLATPAK (F)	CERAMIC DIP (D)	PLASTIC DIP (P)	FLATPAK (F)
9S20	6A	3I	6A		3I
9S22	6A	3I	6A		3I
9S40	6A	3I	6A		3I
9S64	6A	3I	6A		3I
9S65	6A	3I	6A		3I
9S74	6A	3I	6A		3I
9S109	6B	4L	6B		4L
9S112	6B	4L	6B		4L
9S113	6A	3I	6A		3I
9S114	6A	3I	6A		3I
9S140	6A	3I	6A		3I
9300	7B	4L	7B		4L
93H00	7B	4L	7B		4L
9301	7B	4L	7B		4L
9302	7B	4L	7B		4L
9304	6B	4L	6B		4L
9305	7A	3B	7A		3B
9307	6B	4L	6B		4L
9308	6N	4M	6N	9N	4M
9309	6B	4L	6B		4L
9310	7B	4L	7B		4L
9311	6N	4M	6N	9N	4M
9312	7B	4L	7B		4L
9313	7B	4L	7B		4L
9314	7B	4L	7B		4L
9315	6B	4L	6B	9B	4L
9316	7B	4L	7B		4L
9317B	7B	4L	7B		4L
9317C	7B	4L	7B		4L
9318	7B	4L	7B		4L
9321	7B	4L	7B		4L
9322	7B	4L	7B		4L
9324	7B	4L	7B		4L
9328	7B	4L	7B		4L
9334	7B	4L	7B		4L
9338	7B	4L	7B		4L
9340	6N	4M	6N	9N	4M
9341	6N	4M	6N	9N	4M
9342	7B	4L	7B		4L
9344	6N	4M	6N	9N	4M
9345	7B	4L	7B	9B	4L
9348	7B	4L	7B		4L
9350			7A		
9352	6B	4L	6B	9B	4L
9353	6B	4L	6B	9B	4L
9354	6B	4L	6B	9B	4L
9356			7A		
9357A	7B	4L	7B	9B	4L
9357B	7B	4L	7B	9B	4L
9358	7B	4L	7B	9B	4L
9359		3I			3I

PACKAGING INFORMATION

DEVICE	MILITARY (M) -55°C to +125°C		COMMERCIAL (C)/INDUSTRIAL 0°C to +70°C/75°C		
	CERAMIC	FLATPAK (F) DIP (D)	CERAMIC	PLASTIC DIP (D)	FLATPAK (F) DIP (P)
9360	7B	4L	7B	9B	4L
9366	7B	4L	7B	9B	4L
93H72	7B	4L	7B		4L
9375	6B	4L	6B	9B	4L
9377		3I			3I
9380	6A	3I	6A	9A	3I
9382	6A	3I	6A	9A	3I
9383	6B	4L	6B	9B	4L
9386	7A	3B	7A		3B
93H87	7A	3B	7A		3B
9390	6A	3B	6A	9A	3B
9391	6A	3I	6A	9A	3I
9392	6A	3B	6A	9A	3B
9393	6A	3B	6A	9A	3B
9394	6B	4L	6B	9B	4L
9395	6A	3I	6A	9A	3I
9396	7B	4L	7B	9B	4L
93141			6B	9B	
93145	7B	4L	7B	9B	4L
93150	6N	4M	6N	9N	4M
93151	7B	4L	7B	9B	4L
93152	7A	3B	7A	9A	3B
93153	7B	4L	7B	9B	4L
93164	7A	3B	7A	9A	3B
93165	7B	4L	7B	9B	4L
93180	7A	3B	7A	9A	3B
93H183	7A	3B	7A		3B
93190	7B	4L	7B	9B	4L
93191	7B	4L	7B	9B	4L
93196	7A	3B	7A	9A	3B
93197	7A	3B	7A	9A	3B
93198	6N	4M	6N	9N	4M
93400			7B		
93400B			7B		
93401			7B		
93402			6N		
93403			7B		4L
93406			7K		
93407/A			6A		3I
93407/B	6A	3I	6A		3I
93410	7K		7K		
93410A			7K		
93415			7K		
93433/A			6A		3I
93433/B	6A	3I	6A		3I
93434	7B		7B		
93435	7U		7U		
93L00	7B	4L	7B		4L
93L01	7B	4L	7B		4L
93L08	6N	4M	6N		4M
93L09	6B	4L	6B		4L
93L10	7B	4L	7B		4L
93L11	6N	4M	6N		4M
93L12	7B	4L	7B		4L

10

PACKAGING INFORMATION

DEVICE	MILITARY (M) -55°C to +125°C		COMMERCIAL (C)/INDUSTRIAL 0°C to +70°C/75°C		
	CERAMIC DIP (D)	FLATPAK (F)	CERAMIC DIP (D)	PLASTIC DIP (P)	FLATPAK (F)
93L14	7B	4L	7B		4L
93L16	7B	4L	7B		4L
93L18	7B	4L	7B		4L
93L21	7B	4L	7B		4L
93L22	7B	4L	7B		4L
93L24	7B	4L	7B		4L
93L28	7B	4L	7B		4L
93L40	6N	4M	6N		4M
93S00	7B	4L	7B		4L
93S05	7A	3B	7A		3B
93S10	7B	4L	7B		4L
93S12	7B	4L	7B		4L
93S16	7B	4L	7B		4L
93S41	6N	4M	6N		4M
93S42	7B	4L	7B		4L
93S62	7A	3B	7A		3B
9600	6A	3I	6A	9A	3I
9601	6A	3I	6A	9A	3I
9602	6B	4L	6B		4L
96L02	6B	4L	6B		4L
9603	6A	3I	6A	9A	3I
9614	7B	4L	7B		4L
9615	7B	4L	7B		4L
9616			6A		
9617			6A		
9620	6A	3I	6A		3I
9621	6A	3I	6A		3I
9622	6A	3I	6A		3I
9624	6A	3I	6A		3I
9625	6A	3I	6A		3I
9644	7B		7B		

PACKAGE PHYSICAL DIMENSIONS

in accordance with
JEDEC (TO-86) outline
14 Lead MSI Cerpak

3B

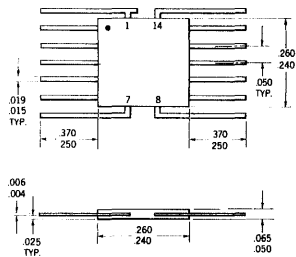

NOTES: All dimensions in inches
Leads are gold-plated kovar
Package weight is 0.26 gram
Lead 1 orientation may be either tab or dot

in accordance with
JEDEC (TO-86) outline
14 Lead Cerpak

3I

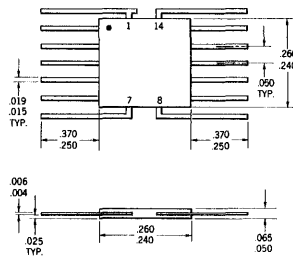

NOTES: All dimensions in inches
Leads are gold-plated kovar
Package weight is 0.26 gram
Lead 1 orientation may be either tab or dot

PACKAGE PHYSICAL DIMENSIONS

16 Lead Cerpak

4L

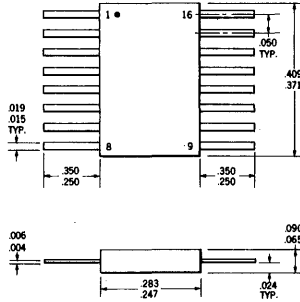

NOTES: All dimensions in inches
Leads are gold-plated kovar
Package weight is 0.4 gram

24 Lead BeO Cerpak

4M

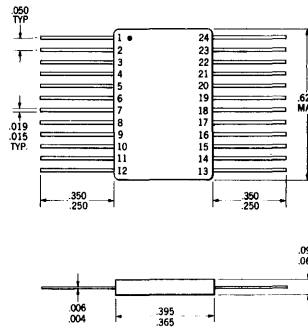

NOTES: All dimensions in inches
Leads are gold-plated kovar
Package weight is 0.6 gram

in accordance with
JEDEC (TO-116) outline
14 Lead SSI Dual In-line

6A

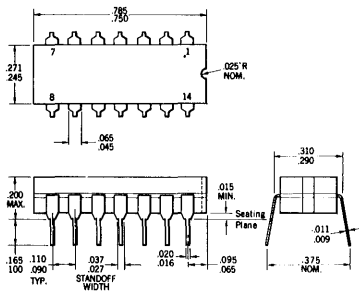

NOTES: All dimensions in inches
Leads are intended for insertion in hole rows on .300" centers
They are purposely shipped with "positive" misalignment to facilitate insertion
Board-drilling dimensions should equal your practice for .020 inch diameter lead
Leads are tin-plated kovar
Package weight is 2.0 grams

16 Lead SSI Dual In-line

6B

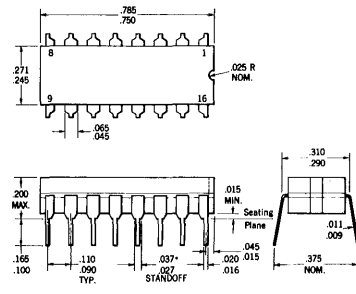

NOTES: All dimensions in inches
Leads are intended for insertion in hole rows on .300" centers
They are purposely shipped with "positive" misalignment to facilitate insertion
Board-drilling dimensions should equal your practice for .020 inch diameter lead
Leads are tin-plated kovar
Package weight is 2.0 grams
*The .0371 / .027 dimension does not apply to the corner leads

24 Lead MSI Dual In-line

6N

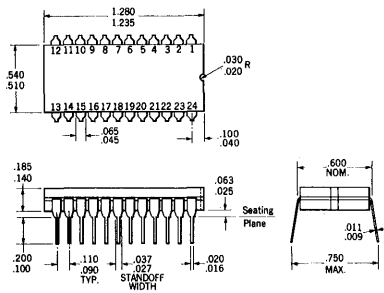

NOTES: All dimensions in inches
Leads are intended for insertion in hole rows on .600" centers
They are purposely shipped with "positive" misalignment to facilitate insertion
Leads are tin-plated kovar
Package weight is 6.6 grams

Similar* to
JEDEC (TO-116) outline
14 Lead MSI Dual In-line

7A

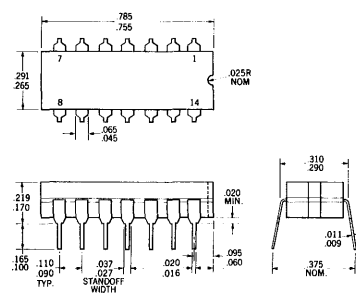

NOTES: All dimensions in inches
Leads are intended for insertion in hole rows on .300" centers
They are purposely shipped with "positive" misalignment to facilitate insertion
Board-drilling dimensions should equal your practice for .020 inch diameter lead
Leads are tin-plated kovar
Package weight is 2.2 grams
*Similar to JEDEC TO-116 except for package width

10

PACKAGE PHYSICAL DIMENSIONS

16 Lead MSI Dual In-line

7B

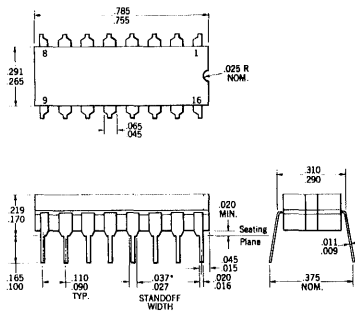

NOTES: All dimensions in inches
Leads are intended for insertion in hole rows on .300" centers
They are purposely shipped with "positive" misalignment to facilitate insertion
Board-drilling dimensions should equal your practice for .020 inch diameter lead
Leads are tin-plated kovar
Package weight is 2.2 grams
*The .037 dimension does not apply to the corner leads

16 Lead Dual In-line (Metal Cap)

7K

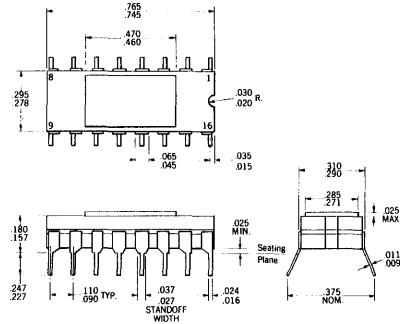

NOTES: All dimensions in inches
Leads are intended for insertion in hole rows on .300" centers
They are purposely shipped with "positive" misalignment to facilitate insertion
Board-drilling dimensions should equal your practice for .020 inch diameter lead
Leads are gold-plated kovar
Low temperature seal
Package weight is 1.3 grams

36 Lead Side Brazed Dual In-line

7U

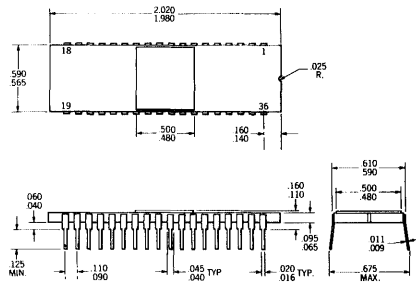

NOTES: All dimensions in inches
Leads are intended for insertion in hole rows on .600" centers
They are purposely shipped with "positive" misalignment to facilitate insertion
Leads are gold-plated kovar
Package weight is 6.2 grams

in accordance with JEDEC (TO-116) outline

9A

14 Lead Silicene Dual In-line

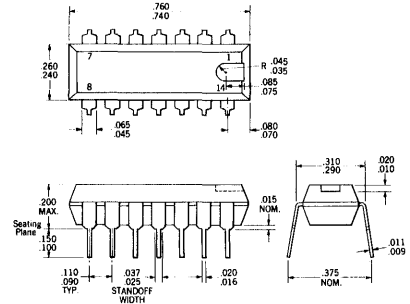

NOTES: All dimensions in inches
Leads are intended for insertion in hole rows on .300" centers
They are purposely shipped with "positive" misalignment to facilitate insertion
Board-drilling dimensions should equal your practice for .020 inch diameter lead
Leads are tin-plated kovar
Package weight is 0.9 grams

16 Lead Silicone Dual In-line

9B

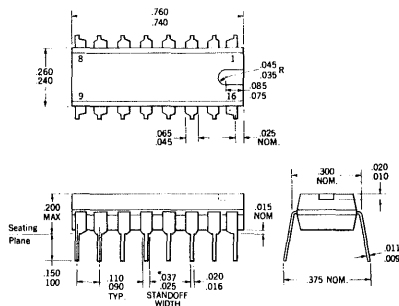

NOTES: All dimensions in inches
Leads are intended for insertion in hole rows on .300" centers
They are purposely shipped with "positive" misalignment to facilitate insertion
Board-drilling dimensions should equal your practice for .020 inch diameter lead
Leads are tin-plated kovar
Package weight is 0.9 grams
*The .037/.027 dimension does not apply to the corner leads

24 Lead Plastic MSI Dual In-line

9N

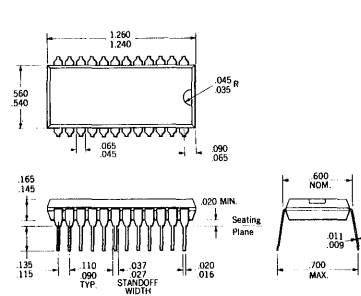

NOTES: All dimensions in inches
Leads are intended for insertion in hole rows on .600" centers
They are purposely shipped with "positive" misalignment to facilitate insertion
Leads are tin-plated kovar
Package weight is 2.7 grams

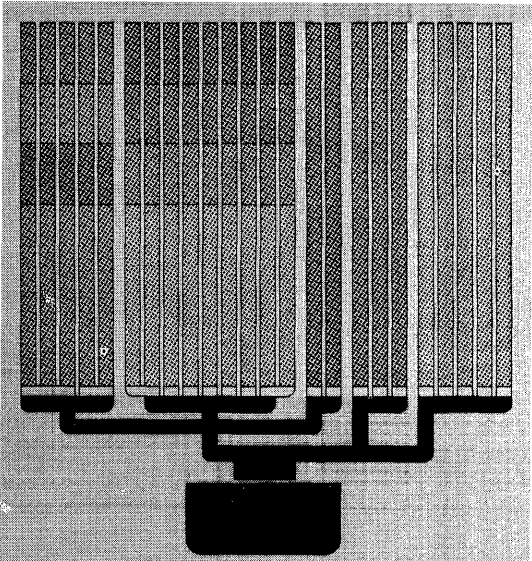

Industry Cross Reference Guide

INDUSTRY TTL CROSS REFERENCE GUIDE

The following charts indicate the recommended Fairchild replacement for the most popular TTL devices in use today. Two categories of replacement are given.

1. Pin for Pin Replacement

Function and pin configuration are identical, however some small differences in the electrical or mechanical specification or method of test may exist.

2. Functional Equivalent

Device performing similar function, but with different pin outs, or organization.

Exact interchangeability in every application is not guaranteed. Before specifying a substitute, the user should compare the most recent data and device parameters from both sources of supply.

Cross reference information is provided for the following manufacturers.

- | | | |
|----------------------------|------------|---------------------|
| • Advanced Micro Devices | • ITT | • Philips |
| • Computer Microtechnology | • Motorola | • Signetics |
| • Intel | • National | • Texas Instruments |

AMD – ADVANCED MICRO DEVICES

DEVICE ORDER NUMBER FORMAT

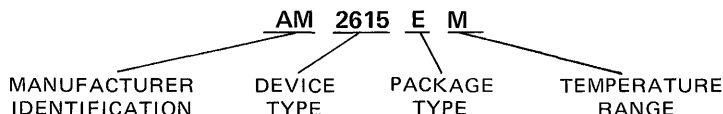

PACKAGE CROSS REFERENCE

PACKAGE	AMD	FAIRCHILD
Dual In-Line Ceramic	U7B, E,F,G, U6N, U6B, U6A	D
Dual In-Line Plastic	U6E, U6M, A,B,C	P
Flatpak	U4L, U4M, U3I, M,N,P	F

TEMPERATURE RANGE CROSS REFERENCE

TEMPERATURE RANGE	AMD	FAIRCHILD
COMMERCIAL 0°C to +70°C/75°C	C, 59X	C
MILITARY -55°C to +125°C	M, 51X	M

AMD	FAIRCHILD PIN FOR PIN REPLACEMENT	FAIRCHILD FUNCTIONAL EQUIVALENT	AMD	FAIRCHILD PIN FOR PIN REPLACEMENT	FAIRCHILD FUNCTIONAL EQUIVALENT	AMD	FAIRCHILD PIN FOR PIN REPLACEMENT	FAIRCHILD FUNCTIONAL EQUIVALENT
2501		9366	9306	9306		9324	9324	
2505		9344	9308	9308		93L24	93L24	
2506		9341	93L08	93L08		9328	9328	
2600		9600	9309	9309		93L28	93L28	
2602		9602	93L09	93L09		9338	9338	
26L02		96L02	9310	9310		93L38		9338
2614		9614	93L10	93L10		9340	9340	
2615		9615	9311	9311		93L40	93L40	
2700		93410	93L11	93L11		9341	9341	
3101	93403		9312	9312		93L41		9341
31L01		93403	93L12	93L12		9342	9342	
54181	9341		9314	9314		9600	9600	
54182	9342		93L14	93L14		9601	9601	
9300	9300		9316	9316		9602	9602	
93L00	93L00		93L16	93L16		96L02	96L02	
9301	9301		9318	9318		9614	9614	
93L01	93L01		93L18	93L18		9620	9620	
9304	9304		9322	9322		9621	9621	
			93L22	93L22				

CMI – COMPUTER MICROTECHNOLOGY INC.

DEVICE ORDER NUMBER FORMAT

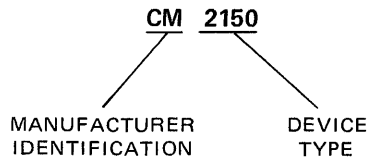

CMI	FAIRCHILD PIN FOR PIN REPLACEMENT	FAIRCHILD FUNCTIONAL EQUIVALENT
2100	93403	
2150	93410	
2800		93406
2850	93406	

INTEL

DEVICE ORDER NUMBER FORMAT

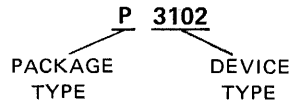

PACKAGE CROSS REFERENCE

PACKAGE	INTEL	FAIRCHILD
Dual In-Line Ceramic	C	D
Dual In-Line Plastic	P	P

INTEL	FAIRCHILD PIN FOR PIN REPLACEMENT	FAIRCHILD FUNCTIONAL EQUIVALENT	INTEL	FAIRCHILD PIN FOR PIN REPLACEMENT	FAIRCHILD FUNCTIONAL EQUIVALENT	INTEL	FAIRCHILD PIN FOR PIN REPLACEMENT	FAIRCHILD FUNCTIONAL EQUIVALENT
3101	93403		3106		93410	3202	93401	
3101A		93403	3106A		93410	3205		9301
3102	93400		3107		93410	3404		9314
3104	93402		3107A		93410	3301	93406	

ITT SEMICONDUCTORS

DEVICE ORDER NUMBER FORMAT

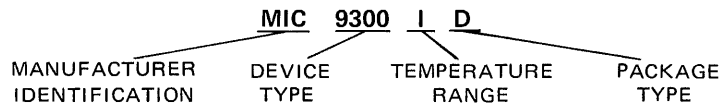

PACKAGE CROSS REFERENCE

PACKAGE	ITT	FAIRCHILD
Dual In-Line Ceramic	D	D
Dual In-Line Plastic	—	P
Flatpak	B	F

TEMPERATURE RANGE CROSS REFERENCE

TEMPERATURE RANGE	ITT	FAIRCHILD
COMMERCIAL 0°C to +70°C/75°C	5	C
MILITARY -55°C to +125°C	1	M

ITT	FAIRCHILD PIN FOR PIN REPLACEMENT	FAIRCHILD FUNCTIONAL EQUIVALENT	ITT	FAIRCHILD PIN FOR PIN REPLACEMENT	FAIRCHILD FUNCTIONAL EQUIVALENT	ITT	FAIRCHILD PIN FOR PIN REPLACEMENT	FAIRCHILD FUNCTIONAL EQUIVALENT
5033	93407	93433	9008	9008		9033	93433	93407
9000	9000		9009	9009		9300	9300	
9001	9001		9014	9014		9301	9301	
9002	9002		9015	9015		9304	9304	
9003	9003		9016	9016		9309	9309	
9004	9004		9017	9017		9312	9312	
9005	9005		9022	9022		9316	9316	
9006	9006		9024	9024		9601	9601	
9007	9007							

MOTOROLA

DEVICE ORDER NUMBER FORMAT

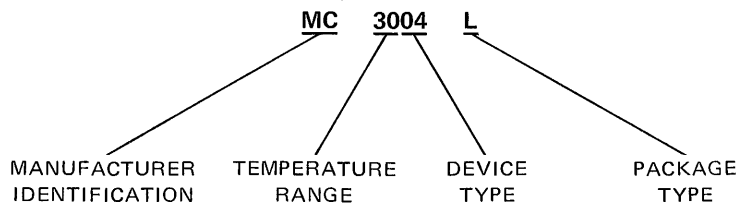

PACKAGE CROSS REFERENCE

PACKAGE	MOTOROLA	FAIRCHILD
Dual In-Line Ceramic	L	D
Dual In-Line Plastic	P	P
Flatpak	F	F

TEMPERATURE RANGE CROSS REFERENCE

TEMPERATURE RANGE	MOTOROLA	FAIRCHILD
COMMERCIAL 0°C to +70°C/75°C	30,40,72,74,83	C
MILITARY -55°C to +125°C	31,43,82,54,93	M

MOTOROLA	FAIRCHILD PIN FOR PIN REPLACEMENT	FAIRCHILD FUNCTIONAL EQUIVALENT	MOTOROLA	FAIRCHILD PIN FOR PIN REPLACEMENT	FAIRCHILD FUNCTIONAL EQUIVALENT	MOTOROLA	FAIRCHILD PIN FOR PIN REPLACEMENT	FAIRCHILD FUNCTIONAL EQUIVALENT	
5400	See T.I. Cross Reference		3025		9H40, 74H40	4018		9316	
54H00			3026			9H40, 74H40		4021	9324
7400			3030			9H60, 74H60		4022	9324
74H00			3031			9H52, 74H52		4023	9305
3000	9H00, 74H00	9N02, 7402, 9015 9N32, 7432	3032	9H53, 74H53	4026	4026	9304		
3001	9H08, 74H08		3033	9H54, 74H54	4027	4027	9304		
3002			3034	9H55, 74H55	4028	4028	9341		
3003			3054	9H71, 74H71	4032	4032	9342		
3004	9H01, 74H01		3055	9H72, 74H72	4035	4035	9314		
3005	9H10, 74H10		3060		9H74, 74H74	4037	4037	9314	
3006	9H11, 74H11		3061	9S114	9H78, 74H78	4039	4039	9307	
3007			3062	9S113	9H103, 74H103	4064	93403		
3008	9H04, 74H04		3063	9H73, 74H73		7242	9386		
3009	9H05, 74H05		4000		9309	8242	9386		
3010	9H20, 74H20	4001		93434	8300	9300			
3011	9H21, 74H21	4002(MCM)	93434		8301	9301			
3012	9H22, 74H22	4004	93407	93433	8304	9304			
3015		4005	93407	93433	8308	9308			
3016	9H30, 74H30	4006		9321	8309	9309			
3018	9H62, 74H62	4007		9321	8310	9310			
3019	9H61, 74H61	4008		9348	8311	9311			
3020	9H50, 74H50	4010		9348	8312	9312			
3021		4012		9300, 93H72	8316	9316			
3022		4015		93174	8328	9328			
3023	9H51, 74H51	4016		9310	8601	9601			
3024	9H40, 74H40								

**NATIONAL
DEVICE ORDER NUMBER FORMAT
DM 8213 D**

MANUFACTURER IDENTIFICATION TEMPERATURE RANGE DEVICE TYPE PACKAGE TYPE

PACKAGE CROSS REFERENCE

PACKAGE	NATIONAL	FAIRCHILD
Dual In-Line Ceramic Dual In-Line Plastic Flatpak	D N F	D P F

TEMPERATURE RANGE CROSS REFERENCE

TEMPERATURE RANGE	NATIONAL	FAIRCHILD
COMMERCIAL 0°C to +70°C/75°C MILITARY -50°C to +125°C	8,74 7,54	C M

NATIONAL	FAIRCHILD PIN FOR PIN REPLACEMENT	FAIRCHILD FUNCTIONAL EQUIVALENT	NATIONAL	FAIRCHILD PIN FOR PIN REPLACEMENT	FAIRCHILD FUNCTIONAL EQUIVALENT	NATIONAL	FAIRCHILD PIN FOR PIN REPLACEMENT	FAIRCHILD FUNCTIONAL EQUIVALENT	
5400	See T.I. Cross Reference		8290	93196		8533	9393		
54H00			8291	93197		8550	9375		
7400			8300	9300		8551			9314
74H00			8309	9309		8560	9360		
8200			9324	8310		9310	8563		9366
8210		9312	8311	9311	8570	93164			
8211		9312	8312	9312	8580	9395			
8213	9311		8316	9316	8582		93410		
8220		9348	8322	9322	8588	93434			
8223		9321	8520		9305	8590	93165		
8280	93176		8530	9390		8601	9601		
8281	93177		8532	9392		8602	9602		
8283	9383								

**PHILIPS
DEVICE ORDER NUMBER FORMAT
FJH 341**

TTL FAMILY DESIGNATION CIRCUIT FUNCTION DEVICE NUMBER TEMPERATURE RANGE

PACKAGE CROSS REFERENCE

PACKAGE	PHILIPS	FAIRCHILD
Dual In-Line Ceramic Dual In-Line Plastic Flatpak	- A, B -	D P F

TEMPERATURE RANGE CROSS REFERENCE

TEMPERATURE RANGE	PHILIPS	FAIRCHILD
COMMERCIAL 0°C to +70°C/75°C MILITARY -55°C to +125°C	1 2	C M

PHILIPS	FAIRCHILD PIN FOR PIN REPLACEMENT	FAIRCHILD FUNCTIONAL EQUIVALENT	PHILIPS	FAIRCHILD PIN FOR PIN REPLACEMENT	FAIRCHILD FUNCTIONAL EQUIVALENT	PHILIPS	FAIRCHILD PIN FOR PIN REPLACEMENT	FAIRCHILD FUNCTIONAL EQUIVALENT
FJH101	9N30, 7430		FJH261	9352, 7442		FJJ131	9N74, 7474	
FJH111	9N20, 7420		FJH291	9N03, 7403		FJJ141	9390, 7490	9350
FJH121	9N10, 7410		FJH301	9N26, 7426		FJJ151	9391, 7491	
FJH131	9N00, 7400		FJH311		9N01, 7401	FJJ181	9375, 7475	
FJH141	9N40, 7440		FJH321		9N05, 7405	FJJ191	9N76, 7476	
FJH151	9N50, 7450		FJH331		9348	FJJ211	9393, 7493	9356
FJH161	9N51, 7451		FJH341	9311		FJJ251	9392, 7492	
FJH171	9N53, 7453		FJH351	9312		FJJ261	9N107, 74107	
FJH181	9N54, 7454		FJH391	9322		FJJ321	9300	
FJH191	9380, 7480		FJH401	9309		FJJ401	93191	
FJH201	9382, 7482		FJH431		9311	FJJ411	9366	
FJH211	9383, 7483		FJH441	93151	9312	FJK101	9603, 74121	
FJH221	9N02, 7402		FJH451	9341		FJL101	9315, 7441	
FJH231	9N01, 7401		FJH491		9321	FJY101	9N60, 7460	
FJH241	9N04, 7404		FJJ101	9N70, 7470		FJQ101		9338
FJH251	9N05, 7405		FJJ111	9N72, 7472		FJQ111	93403	
			FJJ121	9N73, 7473		FJR101	93434	

SIGNETICS

DEVICE ORDER NUMBER FORMAT

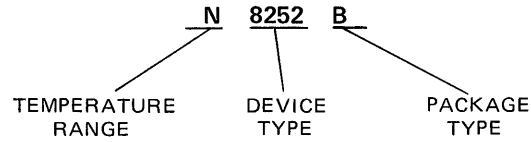

PACKAGE CROSS REFERENCE

PACKAGE	SIGNETICS	FAIRCHILD
Dual In-Line Ceramic	E, F, Y	D
Dual In-Line Plastic	A, B, N	P
Flatpak	J, Q, P, R	F

TEMPERATURE RANGE CROSS REFERENCE

TEMPERATURE RANGE	SIGNETICS	FAIRCHILD
COMMERCIAL 0°C to +70°C/75°C	N	C
MILITARY -55°C to +125°C	S	M

SIGNETICS	FAIRCHILD PIN FOR PIN REPLACEMENT	FAIRCHILD FUNCTIONAL EQUIVALENT	SIGNETICS	FAIRCHILD PIN FOR PIN REPLACEMENT	FAIRCHILD FUNCTIONAL EQUIVALENT	SIGNETICS	FAIRCHILD PIN FOR PIN REPLACEMENT	FAIRCHILD FUNCTIONAL EQUIVALENT	
5400	See T.I. Cross Reference		8252	9301		8808		9N30, 7430	
54H00			8260			9341		8815	9N25, 7425
54S00			8261			9342		8816	9N20, 7420
7400			8262			9348		8821	9N76, 7476
74H00			82S62	93S62				8822	9N73, 7473
74S00			8263			9309		8824	9N76, 7476
8206		93410	82S63	9309	8825		9N70, 7470		
8207		93410	8264	9309	8827		9N73, 7473		
8220		93402	82S64	9309	8828		9N74, 7474		
8223		93434	8266	9322	8829		9N72, 7472		
8224	93434		8267	9322	8840		9N50, 7450		
8225	93403		8268	9380	8848		9N53, 7453		
8226		93406	8269	9324	8855		9N40, 7440		
8229		93406	8270	93H72	8870		9N10, 7410		
8230	9312		8271	93178	93H72	8880		9N00, 7400	
82S30	93S12		8275	93179	9314	8881		9N01, 7401	
8231	9313		8276		9391	8885		9N02, 7402	
82S31		9313	8277	9328		8H16		9H20, 74H20	
8232		9312	8280	93176	9310	8H20		9H106	
82S32		9312	8281	93177	9316	8H21		9H108	
8233		9322	8284		93191	8H22		9H108	
82S33		9322	8285		93190	8H70		9H10	
8234		9322	8288		9392	8H90		9H00	
82S34		9322	8290	93196	9310	8T01		9315	
8235		9322	82S90		93S10	8T04		9307	
82S35		9322	8291	93197	9316	8T05		9307	
8241		9N86, 7486	82S91		93S16	8T06		9307	
82S41		9N86, 7486	8292		93L10	8T15		9616	
8242	9386		8293		93L16	8T16		9617	
82S42		9386	8806		9N60, 7460	8T22	9601		

TEXAS INSTRUMENTS

DEVICE ORDER NUMBER FORMAT

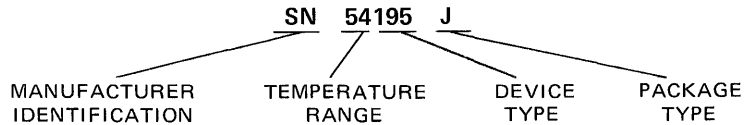

PACKAGE CROSS REFERENCE

PACKAGE	T.I.	FAIRCHILD
Dual In-Line Ceramic	J	D
Dual In-Line Plastic	N	P
Flatpak	T, W	F

TEMPERATURE RANGE CROSS REFERENCE

TEMPERATURE RANGE	T.I.	FAIRCHILD
COMMERCIAL 0°C to +75°C/75°C	74, 75	C
MILITARY -55°C to +125°C	54, 55	M

T.I.	FAIRCHILD PIN FOR PIN REPLACEMENT	FAIRCHILD FUNCTIONAL EQUIVALENT	T.I.	FAIRCHILD PIN FOR PIN REPLACEMENT	FAIRCHILD FUNCTIONAL EQUIVALENT	T.I.	FAIRCHILD PIN FOR PIN REPLACEMENT	FAIRCHILD FUNCTIONAL EQUIVALENT
5400	5400, 9N00	9002	54S20	54S20, 9S20		54H51	54H51, 9H51	
54H00	54H00, 9H00		54H21	54H21, 9H21		54H52	54H52, 9H52	
54L00		9L00	54H22	54H22, 9H22		5453	5453, 9N53	9008
54S00	54S00, 9S00		54S22	54S22, 9S22		54H53	54H53, 9H53	
5401	5401, 9N01	9012	5423	5423, 9N23		5454	5454, 9N54	9008
54H01	54H01, 9H01		5425	5425, 9N25		54H54	54H54, 9H54	
5402	5402, 9N02	9015	5426	5426, 9N26		54H55	54H55, 9H55	
5403	5403, 9N03	9012	5427	5427, 9N27		5460	5460, 9N60	9006
54S03	54S03, 9S03		5430	5430, 9N30	9007	54H60	54H60, 9H60	
5404	5404, 9N04	9016	54H30	54H30, 9H30		54H61	54H61, 9H61	
54H04	54H04, 9H04		5432	5432, 9N32		54H62	54H62, 9H62	
54L04		9L04	5437	5437, 9N37		54S64	54S64, 9S64	
54S04	54S04, 9S04	9S04A	5438	5438, 9N38		54S65	54S65, 9S65	
5405	5405, 9N05	9017	5439	5439, 9N39		5470	5470, 9N70	9001
54H05	54H05, 9H05		5440	5440, 9N40	9009	54H71	54H71, 9H71	
54S05	54S05, 9S05	9S05A	54H40	54H40, 9H40		5472	5472, 9N72	9000
5406	5406, 9N06		54S40	54S40, 9S40		54H72	54H72, 9H72	
5407	5407, 9N07		5441	9315		5473	5473, 9N73	9020
5408	5408, 9N08		5442	5442, 9352	9301	54H73	54H73, 9H73	
54H08	54H08, 9H08		54L42		93L01	5474	5474, 9N74	9024
5409	5409, 9N09		5443	5443, 9353	9311	54H74	54H74, 9H74	9024
5410	5410, 9N10	9003	5444	5444, 9354	9311	54L74		9L24
54H10	54H10, 9H10		5445	5445, 9345		54S74	54S74, 9S74	
5411	5411, 9N11		5446A	5446, 9357A	9317C	5475	5475, 9375	9314
54H11	54H11, 9H11		5447A	5447, 9357B	9317B	5476	5476, 9N76	9022
5412	5412, 9N12		5448	5448, 9358	9307	54H76	54H76, 9H76	
5413	5413, 9N13		5449	5449, 9359	9307	5477	5477, 9377	9314
5416	5416, 9N16		5450	5450, 9N50	9005	54H78	54H78, 9H78	
5417	5417, 9N17		54H50	54H50, 9H50		5480	5480, 9380	9304
5420	5420, 9N20	9004	5451	5451, 9N51	9005	5481	93407	
54H20	54H20, 9H20							

T.I.	FAIRCHILD PIN FOR PIN REPLACEMENT	FAIRCHILD FUNCTIONAL EQUIVALENT	T.I.	FAIRCHILD PIN FOR PIN REPLACEMENT	FAIRCHILD FUNCTIONAL EQUIVALENT	T.I.	FAIRCHILD PIN FOR PIN REPLACEMENT	FAIRCHILD FUNCTIONAL EQUIVALENT
5482	5482, 9382	9304	54162		9310	7408	7408, 9N08	
5483	5483, 9383	9340	54163		9316	74H08	74H08, 9H08	
5484		93433	54164	54164, 93164		7409	7409, 9N09	
5485		9324	54165	54165, 93165		7410	7410, 9N10	9003
54L85		93L24	54166	54166, 93166		74H10	74H10, 9H10	
5486	5486, 9N86	9014	54170		9338	7411	7411, 9N11	
54L86		9L86	54172		9338	74H11	74H11, 9H11	
54H87	54H87, 93H87		54176	54176, 93176		7412	7412, 9N12	
5488A	93434		54177	54177, 93177		7413	7413, 9N13	
5489	93403		54178	54178, 93178		7416	7416, 9N16	
5490	5490, 9390	9350	54179	54179, 93179		7417	7417, 9N17	
54L90		93L10	54180	54180, 93180	9348	7420	7420, 9N20	9004
5491	5491, 9391		54180	54180, 93180	9348	74H20	74H20, 9H20	
5492	5492, 9392	9305	54181	54181, 9341		74S20	74S20, 9S20	
5493	5493, 9393	9356	54S181	54S181, 93S41		74H21	74H21, 9H21	
54L93		93L16	54182	54182, 9342		74H22	74H22, 9H22	
5494	5494, 9394	9300	54S182	54S182, 93S42		74S22	74S22, 9S22	
5495A	5495, 9395	9300	54H183	54H183, 93H183	9304	7423	7423, 9N23	
54L95		93L00	54184	93434		7425	7425, 9N25	
5496	5496, 9396		54185	93434		7426	7426, 9N26	
54L99		93L00	54187	93406		7427	7427, 9N27	
54100		9308	54190	54190, 93190		7430	7430, 9N30	9007
54H101	54H101, 9H101		54191	54191, 93191		74H30	74H30, 9H30	
54H102	54H102, 9H102		54192	54192, 9360		7432	7432, 9N32	
54H103	54H103, 9H103		54193	54193, 9366		7437	7437, 9N37	
54104	9000		54194		93H72			
54105	9001		54195	9300		7438	7438, 9N38	
54H106	54H106, 9H106		54S195	93S00		7439	7439, 9N39	
54107	54107, 9N107		54196	54196, 93196	9310	7440	7440, 9N40	9009
54H108	54H108, 9H108		54197	54197, 93197	9316	74H40	74H40, 9H40	
54110		9001	54198	54198, 93198		74S40	74S40, 9S40	
54S112	54S112, 9S112		54200		93410	7441A	9315	
54S113	54S113, 9S113		54201		93410	7442	7442, 9352	9301
54S114	54S114, 9S114		7400	7400, 9N00	9002	74L42		93L01
54121	54121, 9603		74H00	74H00, 9H00		7443	7443, 9353	9311
54122		9601	74L00		9L00	7444	7444, 9354	9311
54123		9602	74S00	74S00, 9S00		7445	7445, 9345	
54S140	54S140, 9S140		7401	7401, 9N01	9012	7446A	7446, 9357A	9317C
54145	54145, 93145		74H01	74H01, 9H01		7447A	7447, 9357B	9317B
54150	54150, 93150		7402	7402, 9N02	9015	7448	7448, 9358	9307
54151	54151, 93151	9312	7403	7403, 9N03	9012	7449	7449, 9359	9307
54S151		93S12	74S03	74S03, 9S03		7450	7450, 9N50	9005
54152	54152, 93152	9312	7404	7404, 9N04	9016	74H50	74H50, 9H50	
54153	54153, 93153	9309	74H04	74H04, 9H04		7451	7451, 9N51	9005
54L153		93L09	74L04		9L04	74H51	74H51, 9H51	
54154	9311		74S04	74S04, 9S04	9S04A	74H52	74H52, 9H52	
54155		9321	7405	7405, 9N05	9017	7453	7453, 9N53	9008
54157	9322		74H05	74H05, 9H05		74H53	74H53, 9H53	
54160	9310		74S05	74S05, 9S05	9S05A	7454	7454, 9N54	9008
54161	9316		7406	7406, 9N06		74H54	74H54, 9H54	
			7407	7407, 9N07		74H55	74H55, 9H55	

T.I.	FAIRCHILD PIN FOR PIN REPLACEMENT	FAIRCHILD FUNCTIONAL EQUIVALENT	T.I.	FAIRCHILD PIN FOR PIN REPLACEMENT	FAIRCHILD FUNCTIONAL EQUIVALENT	T.I.	FAIRCHILD PIN FOR PIN REPLACEMENT	FAIRCHILD FUNCTIONAL EQUIVALENT
7460	7460, 9N60	9006	74105	9001		74194		93H72
74H60	74H60, 9H60		74H106	74H106, 9H106		74195	9300	
74H61	74H61, 9H61		74107	74107, 9N107	9020	74S195	93S00	
74H62	74H62, 9H62		74H108	74H108, 9H108		74196	74196, 93196	9310
74S64	74S64, 9S64		74S109	74S109, 9S109		74197	74197, 93197	9316
74S65	74S65, 9S65		74110		9001	74198	74198, 93198	
7470	7470, 9N70	9001	74S112	74S112, 9S112		74200		93410
74H71	74H71, 9H71		74S113	74S113, 9S113		74201		93410
7472	7472, 9N72	9000	74S114	74S114, 9S114				
74H72	74H72, 9N72		74121	74121, 9603				
7473	7473, 9N73	9020	74122		9601			
74H73	74H73, 9H73		74123		9602			
7474	7474, 9N74		74S140	74S140, 9S140				
74H74	74H74, 9H74	9024	74141	74141, 93141				
74L74		9L24	74145	74145, 93145				
74S74	74S74, 9S74		74150	74150, 93150				
7475	7475, 9375	9314	74151	74151, 93151	9312			
7476	7476, 9N76	9022	74S151		93S12			
74H76	74H76, 9H76		74152	74152, 93152	9312			
7477	7477, 9377	9314	74153	74153, 93153	9309			
74H78	74H78, 9H78		74L153		93L09			
7480	7480, 9380	9304	74154	9311				
7481	93407		74155		9321			
7482	7482, 9382	9304	74157	9322				
7483	7483, 9383	9340	74160	9310				
7484		93433	74161	9316				
7485		9324	74162		9310			
74L85		93L24	74163		9316			
7486	7486, 9N86	9014	74164	74164, 93164				
74L86		9L86	74165	74165, 93165				
74H87	74H87, 93H87		74166	74166, 93166				
7488A	93434		74170		9338			
7489	93403		74172		9338			
7490	7490, 9390	9350	74176	74176, 93176				
74L90		93L10	74177	74177, 93177				
7491	7491, 9391		74178	74178, 93178				
7492	7492, 9392		74179	74179, 93179				
7493	7493, 9392	9356	74180	74180, 93180	9348			
74L93		93L16	74181	74181, 9341				
7494	7494, 9394	9300	74S181	74S181, 93S41				
7495A	7495, 9395	9300	74182	74182, 9342				
74L95		93L00	74S182	74S182, 93S42				
7496	7496, 9396		74H183	74H183, 93H183	9304			
74L99		93L00	74184	93434 (Option)				
74100		9308	74185	93434 (Option)				
74H10	74H101, 9H101		74187	93406				
74H10	74H102, 9H102		74190	74190, 93190				
74H10	74H103, 9H103		74191	74191, 93191				
74104	9000		74192	74192, 9360				
			74193	74193, 9366				

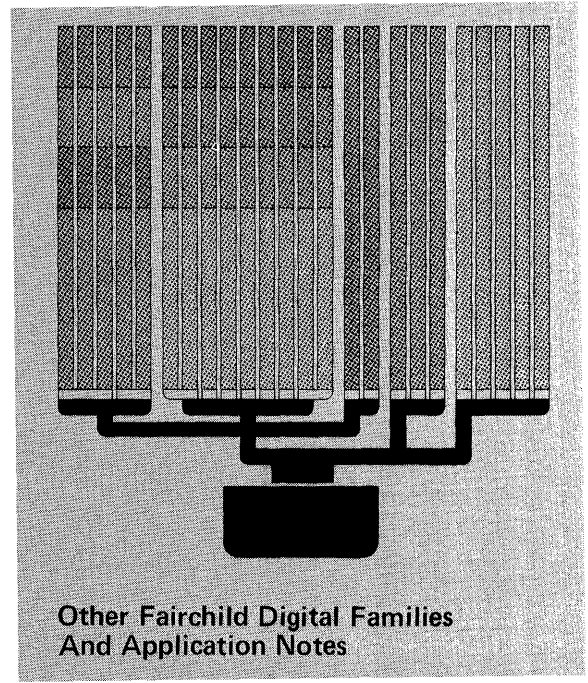

**Other Fairchild Digital Families
And Application Notes**

LIST OF OTHER FAIRCHILD DIGITAL PRODUCTS AND APPLICATION NOTES

In addition to TTL, Fairchild also manufactures other digital logic integrated circuit families. Further information on these other products is available on request from:

Fairchild Semiconductor
P.O. BOX 880A
Mountain View, California 94040
Att. Distribution Services

CTL—COMPLEMENTARY TRANSISTOR LOGIC

9952 Series (CTL I)

9030 8-Bit Memory Cell
9952 Dual 2-Input NOR Gate
9953 AND/OR Gate
9954 AND/OR Gate
9955 AND/OR Gate
9956 Dual 2-Input Buffer
9957 Flip-Flop
9964 AND/OR Gate
9965 AND/OR Gate
9966 AND/OR Gate
9967 Flip-Flop
9968 Dual High Speed Latch
9971 AND/OR Gate
9972 AND/OR Gate

9852 Series (CTL II)

9801 Dual Gated Phase Splitter NOR/OR
9806 Hex Inverter NOR/OR
9816 Hex Restorer (Buffer) AND/OR Gate
9820 100 Ω Line Receiver
9821 100 Ω Line Driver
9822 Dual Full Adder/Subtractor
9823 Carry Lookahead Logic for 9822
9824 4-Bit Comparator
9828 Dual JK-D Flip-Flop
9834 Quad Latch (with output gating)
9838 1-of-8 Decoder
9852 Dual 2-Input Inverter NOR/OR
9853 2-2-3-Input AND/OR Gate
9854 Dual 4-Input AND/OR Gate
9855 Single 8-Input AND/OR Gate
9856 Dual 2-Input Restorer (Buffer) AND/OR Gate
9863 9874 (minus 2 k Ω resistors) AND/OR Gate
9864 3-1-3-Input AND/OR Gate
9865 Quad 1-Input AND/OR Gate
9866 Quad 2-Input (one pair or tied) AND/OR Gate
9871 Quad 2-Input (pairs or tied) AND/OR Gate
9872 9866 (minus 2 K Input resistors) AND/OR Gate
9874 3-2-2-2-Input AND/OR Gate
9875 4-3-3-Input AND/OR Gate
9877 Micro Operator
9881 8-Input Multiplexer
9883 8-Input Priority Encoder

DTL—DIODE TRANSISTOR LOGIC

9930 Series

9930 Dual 4-Input Extendable NAND Gate
9932 Quad 2-Input Extendable NAND Buffer Gate
9933 Extender
9935 Extendable Hex Inverter
9936 Hex Inverter
9937 Hex Inverter
9941 Monostable Multivibrator
9944 Quad 2-Input Extendable NAND Buffer Gate (Open Collector)
9945 RS Flip-Flop
9946 Quad 2-Input NAND Gate
9948 RS Flip-Flop
9949 Quad 2-Input NAND Gate
9950 ac Coupled RS Flip-Flop
9951 Monostable Multivibrator
9961 Dual 4-Input Extendable NAND Gate
9962 Triple 3-Input NAND Gate
9963 Triple 3-Input NAND Gate
9135 Hex Inverter (Open Collector)
9157 Quad 2-Input Buffered NAND Gate
9158 Quad 2-Input Power NAND Gate
9093 Dual JK Flip-Flop
9094 Dual JK Flip-Flop
9097 Dual JK Flip-Flop
9099 Dual JK Flip-Flop
9109 High Voltage Hex Inverter
9110 High Voltage Hex Inverter
9111 RS Flip-Flop
9112 High Voltage Hex Inverter

1800 Series

1800 Dual 5-Input NAND Gate
1801 Dual 5-Input NAND Gate
1802 Single 8-Input NAND Gate
1803 Single 8-Input NAND Gate
1804 Single 10-Input NAND Gate
1805 Single 10-Input NAND Gate
1806 Quad 2-Input AND Gate
1807 Quad 2-Input AND Gate
1808 Quad 2-Input OR Gate
1809 Quad 2-Input OR Gate
1810 Quad 2-Input NOR Gate
1811 Quad 2-Input NOR Gate
1812 Quad 2-Input Exclusive OR Gate
1813 Quad Latch
1814 Quad Latch

ECL – EMITTER COUPLED LOGIC

9500 Series

95H00	4-Bit Universal Register
9502	Dual 4-Input OR/NOR Gate (2.4 ns)
95H02	High Speed 9502 (1.6 ns)
9503	Triple 2-Input OR/NOR Gate (2.4 ns)
95H03	High Speed 9503 (1.6 ns)
9504	Quad 2-Input NOR Gate (2.4 ns)
95H04	High Speed 9504 (1.6 ns)
9505	Quad OR/AND Gate
9507	Quad AND/NAND Gate
95H10	Synchronous Decade Counter
95H16	Synchronous Binary Counter
95H22	High Input Z 95H02
95L22	Low Power 9502 (20 mW, 2 ns)
95H23	High Input Z 95H03
95L23	Low Power 9503 (20 mW, 2 ns)
95H24	High Input Z 95H04
95L24	Low Power 9504 (20 mW, 2 ns)
9528	160 MHz "Dual D" Flip-Flop
95H28	220 MHz 9528
95H29	210 MHz JK Flip-Flop
9534	Quad Latch
9538	2 Line/8 Line Decoder
*95H39	8-Bit Multiport Memory
95H41	4-Bit ALU
*95H42	Lookahead Unit for 95H41
95H55	5-Bit Comparator
9578	Quad Exclusive-OR Gate/4-Bit Comparator
9579	Quad 2-Input Multiplexer
9580	Triple 2-Input Multiplexer
9581	8-Input Multiplexer
9582	Multifunction Receiver/Schmitt Trigger
95H84	2-Bit Adder/Subtractor
95H90	250 MHz Prescaler (divide by 10/11)
9595	ECL – TTL Converter
95400	64-Bit RAM – 16X4
95401	16-Bit RAM – 16X1
95410	256-Bit RAM – 256X1

95100 Series

*95101	Dual 2-Wide OR-AND/NAND Gate
95102	Dual OR/NOR Gate
95103	Triple OR/NOR Gate
95104	Quad OR/NOR Gate
*95105	4-Wide OR-AND/NAND Gate
*95106	Dual 3-Input, 3-Output OR Gate
*95108	Quad 1-Input OR/NOR Gate
*95109	Dual 3-Input, 3-Output NOR Gate
95110	Synchronous Decade Counter
95116	Synchronous Hexadecimal Counter
95128	Dual D Flip-Flop
95129	JK Flip-Flop
*95134	Quad Latch
*95138	1-of-8 Decoder
95141	4-Bit ALU/Function Generator
*95178	Quad Exclusive OR
*95179	Quad 2-Input Multiplexer
*95180	Triple 2-Input Multiplexer
*95196	Quad ECL–TTL Level Converter
*95197	Quad TTL–ECL Level Converter

RTL – RESISTOR TRANSISTOR LOGIC

9900 Series

9900	Buffer
9901	Counter Adapter
9902	Flip-Flop
9903	3-Input NOR Gate
9904	Half Adder
9905	Half Shift Register
9906	Half Shift Register
9907	4-Input Gate
9908	Adder
9909	Buffer
9910	Dual Gate
9911	Dual Gate W/Inverter
9912	Half Adder
9913	Type D F/F
9914	Dual 2-Input NOR Gate
9915	Dual 3-Input NOR Gate
9921	Expander
9923	JK Flip-Flop
9926	JK Flip-Flop
9927	Quad Inverter
9974	JK Flip-Flop

C μ L (RTL) – COUNTING MICROLOGIC

9958	Decade Counter
9959	4-Bit Latch
9960	Decoder/Driver
9989	Binary Counter

TTL APPLICATIONS NOTE INDEX

The following Applications notes provide further information on many of the devices described in this catalog. New Application notes are prepared often. Check Fairchild Application Index, published quarterly, for the most up to date listing.

APP-161	9300 Shift Register
163	9304 Dual Adder
167	9308 Dual 4-Bit Latch
168	93434 Read Only Memory
170	9311 1-of-16 Decoder
181	9309 and 9312 Multiplexers
182	9328 Dual 8-Bit Shift Register
184	9310/16 Counters
202	Philosophy and Design of MSI
205	Thermal Evaluation of Integrated Circuits
212	Digital Display Systems
219	93400 TTL Random Access Memories for High Speed Applications
220	9334 8-Bit Addressable Latch
294	9338 8-Bit Multiple Port Register
295	9321 Dual 1-of-4 Decoder/Demultiplexer
296	9322 Quad 2-Input Multiplexer
303	9305 Variable Modulo Counter
304	9360/66 Up/Down Counters
305	9348 12-Input Parity Checker/Generator

*To be announced.