

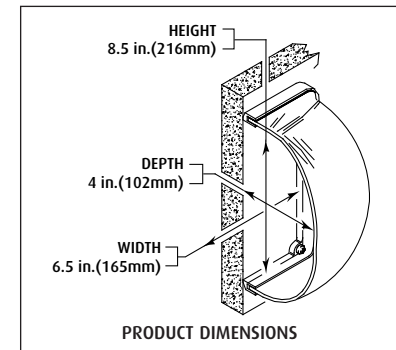

**Safety Technology International, Inc.**  
 2306 Airport Road • Waterford, Michigan 48327-1209  
 Phone: 248-673-9898 • Fax: 248-673-1246  
 Toll Free: 800-888-4784 • E-mail: info@sti-usa.com  
 Web: www.sti-usa.com

**Safety Technology International (Europe) Ltd.**  
 Unit 49G Pipers Road • Park Farm Industrial Estate • Redditch  
 Worcestershire • B98 0HU • England • Tel: 44 (0) 1527 520 999  
 Fax: 44 (0) 1527 501 999 • Freephone: 0800 085 1678 (UK only)  
 E-mail: info@sti-europe.com • Web: www.sti-europe.com

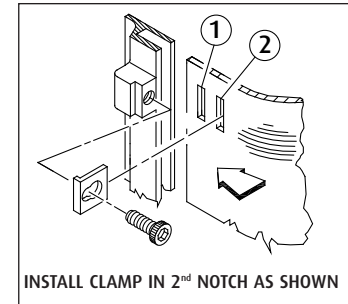
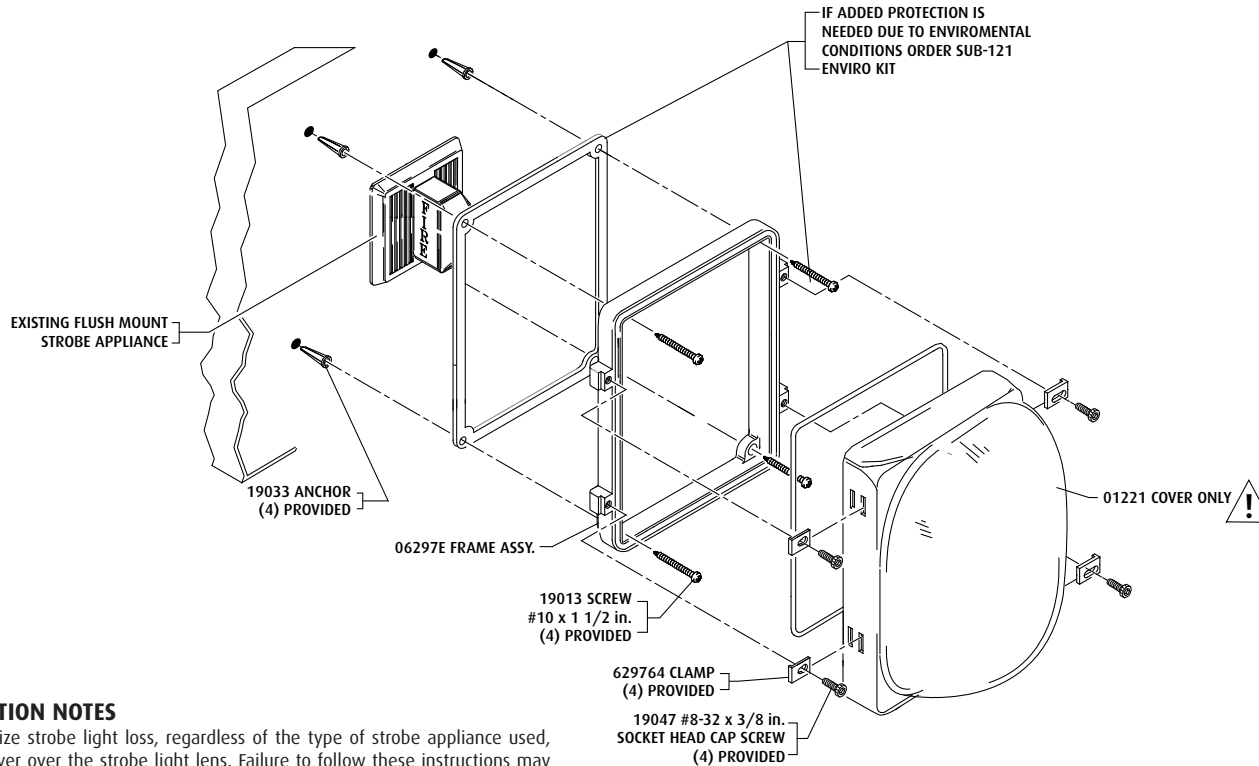

### INSTALLATION NOTES

1. To minimize strobe light loss, regardless of the type of strobe appliance used, center cover over the strobe light lens. Failure to follow these instructions may lead to light loss transmission.
2. Damage Stopper must be installed to comply with applicable NEC, NFPA and local codes.
3. In applications where wash downs, rainfall or condensation occur, it is recommended that a drain or weep hole be provided. Refer to weep hole installation diagram.
4. Damage Stopper may be installed outdoors when appliance carries an outdoor rating.

### INSTALLATION INSTRUCTIONS - REFER TO EXPLODED VIEW

1. Using backbox assembly as a template, place against mounting surface at proper location according to NFPA 72.
2. Mark and drill (4) holes 1/4 in. (6.3mm) diameter, 1 in. (25mm) deep.
4. Insert the (4) anchors into the wall.
4. Mount frame assembly to wall with screws.
5. Install electrical fittings as needed.
6. Install strobe appliance (except for retrofit applications).
7. Install cover with clips and screws.
8. Test appliance according to appliance manufacturer's instructions.

### CLEANING INSTRUCTIONS

Rinse with water to remove abrasive dust and dirt. Wash with soap or mild detergent, using a soft cloth (do not scrub). Rinse once more then dry with a soft cloth or chamois. To remove grease or wet paint, rub gently with a cloth wetted with naphtha. Then wash and rinse. DO NOT USE RAZOR BLADES.

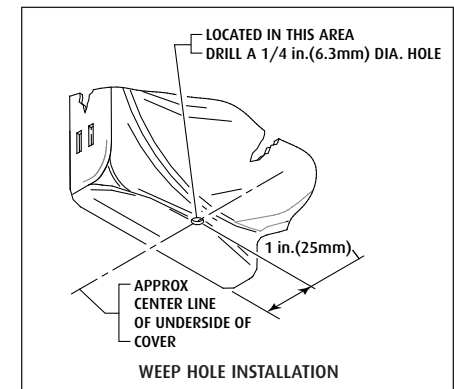

## INSTALLATION OF STI-1221E STROBE DAMAGE STOPPER®

All specifications and information shown were current as of publication, and are subject to change without notice.

1221EIS APRIL2006



## UL INSTALLATION REQUIREMENTS STI-1210 / STI-1221 SERIES

### CAUTION:

- This enclosure is rated to protect signaling appliances indoors and in areas of indirect weather exposure. The cover may be used outdoors only with devices also suitable for outdoor use.
- When covering fire-signaling appliances with this enclosure, some light and sound loss occurs. Please follow these guidelines listed during installation.
- Voice speaker appliance: No spacing adjustment is required for 0.5W, 1.0W and 2.0W appliances.
- Refer to the appliance manufacturer's candela rating. Multiply this number by the light loss value from the chart below to determine the new candela rating. Use this number and refer to the notification layout table of NFPA 72 for proper device locations.
- The use of this cover on audible devices decreases the sound output by 6dB(A). Actual sound level output should be checked after installation to determine if adequate sound levels exist. Refer to the notification layout table of NFPA 72 for proper device locations.

### Performance Review - LIGHT DERATING FACTOR

MANUFACTURER	SERIES	STI-1210	STI-1221/1221A4X	MANUFACTURER	SERIES	STI-1210	STI-1221/1221A4X
ADT SECURITY	ADTG1-V SERIES	40%	34%	HONEYWELL	XLS202 SERIES	40%	34%
AMSECO	SL24W-153075	22%	37%	HONEYWELL	XLSG1-HV SERIES	40%	34%
AMSECO – COLORED LENSES	SL24W-153075 A, B, G, OR R	47%	26%	HONEYWELL	XLSG1-HOV SERIES	40%	34%
AMSECO – COLORED LENSES	SL24C-3075110 A, B, G, OR R	47%	26%	MIRCOM	FS-240	47%	26%
AMSECO – COLORED LENSES	CSL24W-A, B, G, OR R	47%	26%	MIRCOM	MS SERIES	43%	45%
AMSECO – COLORED LENSES	CSL24C-A, B, G, OR R	47%	26%	MIRCOM	MG1-V SERIES	40%	34%
DETECTION SYSTEMS	GES24 SERIES	-	31%	MIRCOM	MG1-HV SERIES	40%	34%
DETECTION SYSTEMS	GES24-15/75	-	-	MIRCOM	MG1-HOV SERIES	40%	34%
EST / EDWARDS	2440S SERIES	43%	45%	MIRTONE	MG1-V SERIES	43%	45%
EST / EDWARDS	202 SERIES	43%	45%	NATIONAL TIME & SIGNAL	GES24 SERIES	-	31%
EST / EDWARDS	G1-V SERIES	40%	34%	NATIONAL TIME & SIGNAL	GES24-15/75	-	-
EST / EDWARDS	G1-HV SERIES	40%	34%	POTTER ELECTRIC	AS-24-153075R	47%	26%
EST / EDWARDS	G1-HOV SERIES	40%	34%	POTTER ELECTRIC	AS-24-153075W	47%	26%
EST / EDWARDS	EG1-V SERIES	40%	34%	SECUTRON	GES24 SERIES	-	31%
EST / EDWARDS	EG1-HV SERIES	40%	34%	SECUTRON	GES24-15/75	-	-
EST / EDWARDS	EG1-HOV SERIES	40%	34%	SIEMENS	202- SERIES	43%	45%
FARADAY LLC	2700	-	57%	SIEMENS	G1-V SERIES	40%	34%
GENTEX	GES24 SERIES	-	31%	SIEMENS	U-MCS SERIES	-	-
GENTEX	GES24-15/75	-	-	SYSTEM SENSOR	SS24110ADA	46%	37%
HARRINGTON SIGNAL	GES24 SERIES	-	31%	SYSTEM SENSOR	P2, PC2, P4, PC4, SX, SC	53%	61%
HARRINGTON SIGNAL	GES24-15/75	-	-	WHEELock	RSS-24MCW	-	-
HONEYWELL	XLSG1-V SERIES	43%	45%	ZITON PTY LTD	ZG1-V SERIES	40%	34%

**STI-1210 Series Sound Derating Factor**  
 System Sensor P2, PC2, P4, PC4, SX, SC series models: 6.7 dBA  
 General: 6 dBA  
**STI Generic Light Loss Value**  
 STI-1210 Series: 53%; STI-1221 Series: 61%