

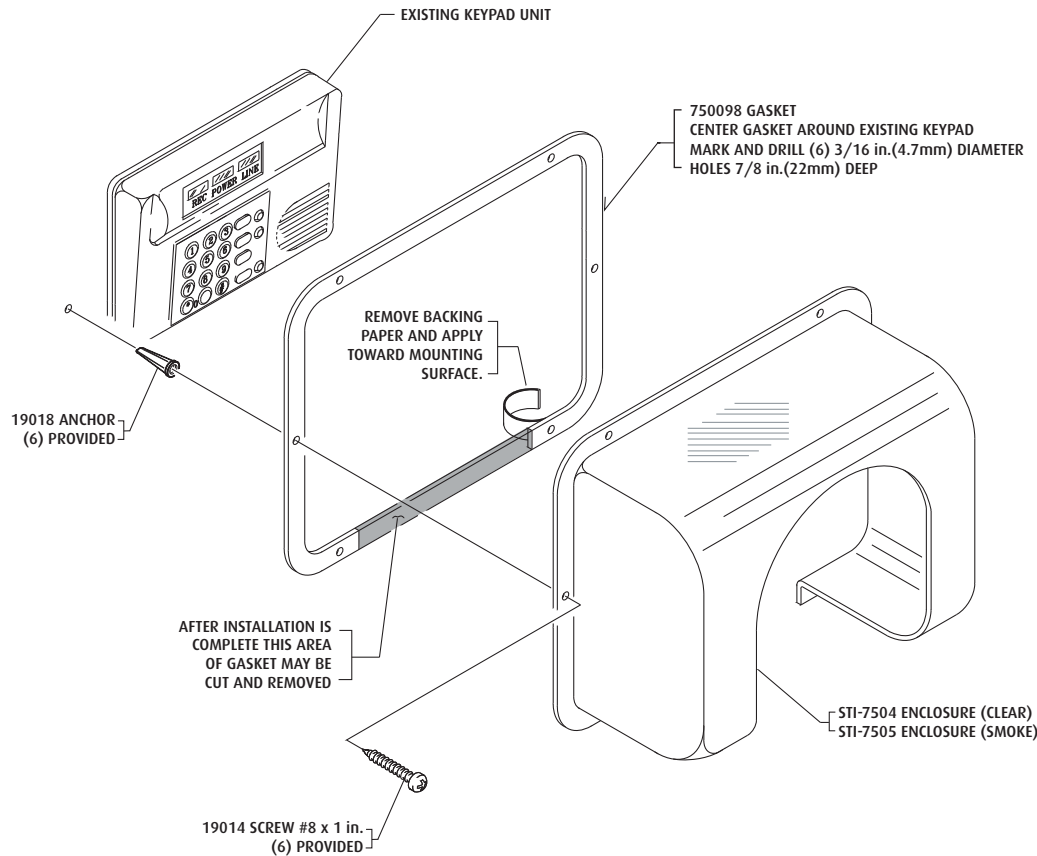

Safety Technology International, Inc.
 2306 Airport Road • Waterford, Michigan 48327-1209
 Phone: 248-673-9898 • Fax: 248-673-1246
 Toll Free: 800-888-4784 • E-mail: info@sti-usa.com
 Web: www.sti-usa.com

Safety Technology International (Europe) Ltd.
 Unit 49G Pipers Road • Park Farm Industrial Estate • Redditch
 Worcestershire • B98 0HU • England • Tel: 44 (0) 1527 520 999
 Fax: 44 (0) 1527 501 999 • Freephone: 0800 085 1678 (UK only)
 E-mail: info@sti-europe.com • Web: www.sti-europe.com



INSTALLATION INSTRUCTIONS

1. Place the cover over the appliance. Be sure that it is accessible through the front opening in cover.
2. Mark and drill 7 holes 3/16 in. (4.7mm).
3. Complete assembly as shown.

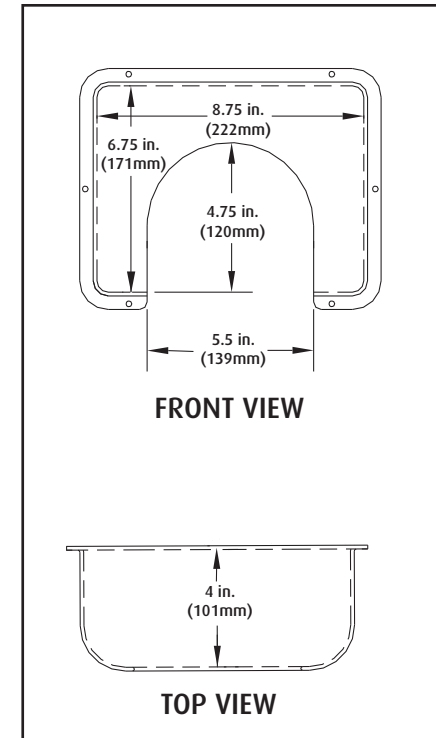

CLEANING INSTRUCTIONS

1. Rinse cover with water to remove abrasive dust and dirt.
2. Wash with soap or mild detergent using a soft cloth. (DO NOT SCRUB.)
3. Rinse once more, then dry with a soft cloth or chamois.
4. To remove grease or wet paint, rub gently with a cloth wetted thoroughly with naphtha, then wash and rinse. (DO NOT USE RAZOR BLADES.)

INSTALLATION OF SNOOPER STOPPERS® STI-7504 AND STI-7505

All specifications and information shown were current as of publication, and are subject to change without notice.

STI-750405IS AUG2006