

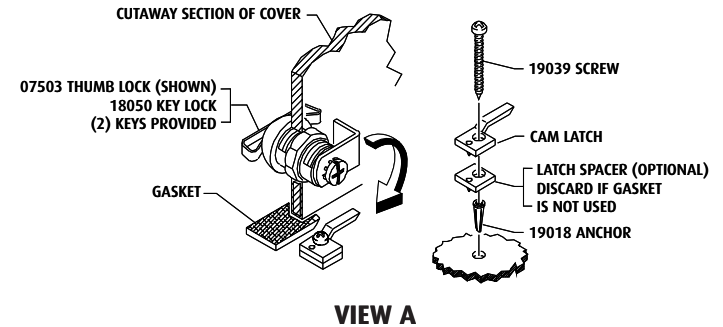

Safety Technology International, Inc.
 2306 Airport Road • Waterford, Michigan 48327-1209
 Phone: 248-673-9898 • Fax: 248-673-1246
 Toll Free: 800-888-4784 • E-mail: info@sti-usa.com
 Web: www.sti-usa.com

Safety Technology International (Europe) Ltd.
 Unit 49G Pipers Road • Park Farm Industrial Estate • Redditch
 Worcestershire • B98 0HU • England • Tel: 44 (0) 1527 520 999
 Fax: 44 (0) 1527 501 999 • Freephone: 0800 085 1678 (UK only)
 E-mail: info@sti-europe.com • Web: www.sti-europe.com

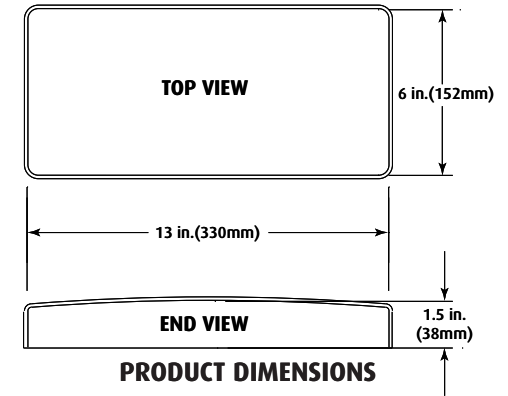
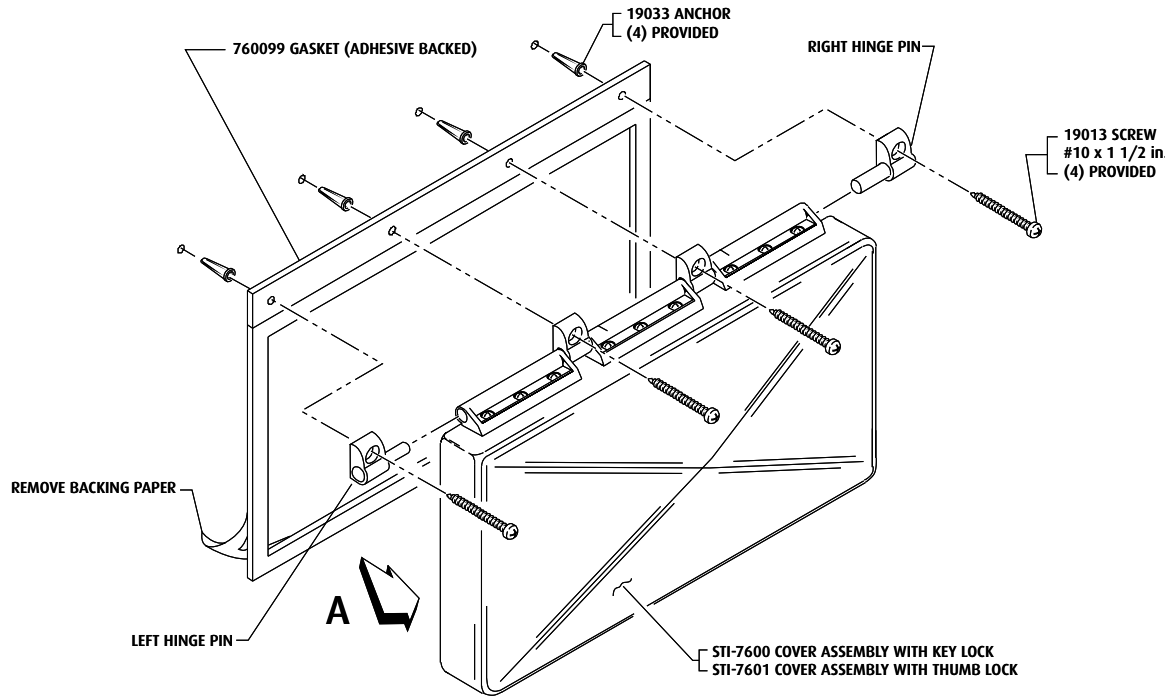

INSTALLATION INSTRUCTIONS

1. Center cover over device to be protected.
2. Place a mark near the location of the cam latch.
3. Install cam latch and latch spacer if gasket is used.
4. Turn key or thumb lock to locked position (cam is facing downward, see view A).
5. Place cover over device making sure cam is fully engaged under cam latch (see view A).
6. Force cover against wall and mark mounting holes.
7. Remove cover and drill 3/16 in.(4.7mm) diameter holes.
8. Install gasket and cover assembly with screws provided. The use of provided anchors is optional.

CLEANING INSTRUCTIONS

1. Rinse cover with water to remove abrasive dust and dirt.
2. Wash with soap or mild detergent using a soft cloth. (DO NOT SCRUB.)
3. Rinse once more, then dry with a soft cloth or chamois.
4. To remove grease or wet paint, rub gently with a cloth wetted thoroughly with naphtha, then wash and rinse. (DO NOT USE RAZOR BLADES.)

INSTALLATION OF STI-7600 MEGA STOPPER®

All specifications and information shown were current as of publication, and are subject to change without notice.