

## Installation

1. The M1DBHR can be mounted inside the M1 enclosure on the left or right hand side of the M1 board using the supplied ELK-SWG Circuit Board Glides. If all the mounting locations are consumed, an additional ELK-SWB14 or ELK-SWB28 enclosure may be installed.

The ELK-SWG Circuit Board Glides attach to the enclosure at strategically placed 2-hole punch patterns. Note that one hole in each pattern is slightly larger than the other. The small hole is for a 6/32 type "F" mounting screw and the large hole is for a half-moon shape locator tab on the bottom of each glide.



2. Starting at the top, loosely start a 6/32" mounting screw in the small hole of the first 2-hole pattern. Place the slotted edge of a board glide under this screw, making sure that the half-moon tab fits into the larger hole and the grooved edge is facing down. Tighten the screw using a long shafted screwdriver. Install a second board glide in the 2-hole pattern 4" below. Attach the second board glide using the same procedures. The grooved edge of this glide should face up.
3. Slide the M1DBHR board into the grooves provided by the glides. The circuit board should slide freely. If loose or too tight, simply loosen one of the mounting screws and adjust the glide to assure a good fit.

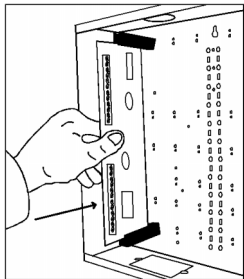

## Wiring Connections

1. Turn Control Panel Master Power Switch Off.
2. Use a 4 wire cable to connect the Controls' Data Bus terminals +VKP, Data A, Data B, and Neg from Control to terminals +, A, B, and - on the M1DBHR. NOTE: If existing wires are already attached to the Data Bus terminals, remove them and follow the detailed wiring diagram on the next page. One of the main purposes of the M1DBHR is to connect and distribute most devices and homeruns through it, as opposed to directly to the main control board.
3. Make all connections as per the diagram on the next page.
4. Power up the Control.

REMEMBER: Any data bus devices that are added to the Control MUST have the address switches properly set and they must be enrolled using the Bus Module Enrollment process under the Installer Level Programming.

# Data Bus Hub Retrofit ELK-M1DBHR

## APPLICATION:

The ELK-M1DBHR is an "active" RS-485 data bus hub designed for jobs where an M1 Control is retrofitting an older panel that has multiple homerun 4 conductor keypad/data wires. It splits the main 485 data bus into 4 managed 485 branches. Each branch can have 2 parallel home run cables for a total of 8 home runs. The end of each cable is EOL terminated to insure proper operation and supervision.

**ELK**  
PRODUCTS, INC.

## Data Bus Hub Retrofit ELK-M1DBHR



## FEATURES:

- Splits The Controls' RS-485 Data Bus Output Into 4 Managed Branches
- Each Managed Branch Can Have 2 Parallel Home Run Cables (Total Of 8 Home Runs)
- EOL Termination Of Each Branch Insures Proper Operation And Supervision
- Works With Std. 4 Conductor Home Run Wire
- An Additional Unit May Be Connected In Parallel To The Control For Expanding Total Capacity
- Includes Mounting Rails for ELK-SWB Boxes

## SPECIFICATIONS:

- Inputs: Elevator Screw Terminals, 4 Position
- Output: Elevator Screw Terminals, 4 Position
- Circuit Board Dimensions: 4.9" x 2.75"

**ELK**  
PRODUCTS, INC.

828-397-4200 Voice  
828-397-4415 Fax  
<http://www.elkproducts.com>  
email: [info@elkproducts.com](mailto:info@elkproducts.com)  
PO Box 100 • Hwy. 70W • Hildebran, NC 28637 • USA

Instructions Printed On Inside

The ELK-M1DBHR "Active" Data Bus Hub Retrofit is ideal for connecting multiple home run cables to the M1. It splits the Controls' main RS-485 Data Bus into 4 managed RS-485 branches. Each branch can have 2 parallel home run cables for a total of 8 home runs. The last (end of line) device on each home run should be jumper terminated to insure proper operation and supervision.

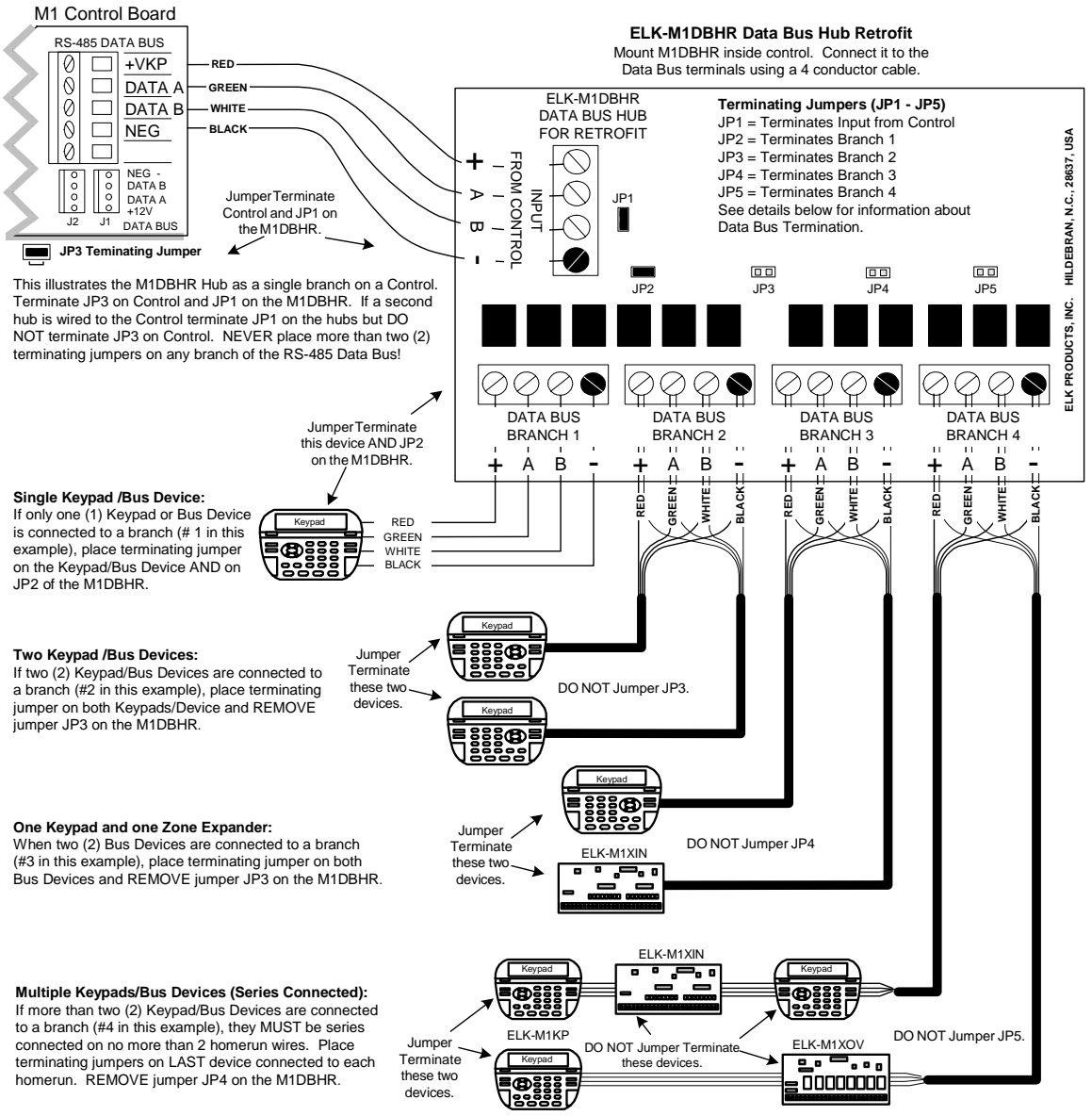

The Maximum length of the RS-485 Data Bus or any single Branch is 4000 ft.  
 Max. devices varies by product. +VVKP protected with 1.25A PTC

**END-OF-LINE DATA BUS TERMINATION IS VERY IMPORTANT!** All data bus devices (keypad, expanders, etc.) have terminating jumpers. The jumpers engage a 120 Ohm resistor across data A & B lines. Refer to the individual instruction manuals and the Control hardware pack for the location of these jumpers. **WARNING! DO NOT place more than two (2) terminating jumpers on any branch of the RS-485 Data Bus. Reliability and response will be negatively affected!**

