

OPERATION

A listen-in session can be initiated two ways.

A. By an alarm from a zone that has the "two way listen-in" option enabled. After the alarm has transmitted, the dialer will hold the line for up to 60 seconds, allowing the CS Operator to press the **DTMF** "Dual tone multi frequency" command *55* to initiate listen-in. If this tone command is not received, the dialer will hang-up and release the phone line.

B. Via the telephone remote control feature, if enabled. Call the control and wait for it to answer. Then enter a valid passcode. Select option 7 "Audio Monitor" and follow the Tone Commands below. Telephone remote control is enabled from Installer Programming, Menu 07 - Global System Definitions, Option G01.

NOTE: An active two way session will terminate automatically after 3 minutes, unless manually extended using DTMF tone command 7.

DTMF TONE COMMAND

DTMF *55* BEGIN LISTEN-IN - For use by the Central Station to initiate listen-in.

DTMF 1 TALK - Mutes all microphones and turns Output 1 speakers ON.
DTMF 2 LISTEN - Turns Output 1 speakers OFF permitting premises listen-in.
DTMF 3 MAX. SENSITIVITY - Raises the gain on microphone sensitivity.
DTMF 4 MICROPHONE SELECT -
40 Selects ALL microphones
41 Selects Microphone Zn 1
42 Selects Microphone Zn 2
43 Selects Microphone Zn 3

NOTE: All 3 mic zones are initially active when listen-in begins.

DTMF 5 - [future use]
DTMF 6 LOW SENSITIVITY - Lowers the gain on microphone gain to minimum sensitivity.
DTMF 7 EXTEND - Restart 3 minute listen-in.
DTMF 8 TERMINATE FOR NOW - Ends the listen-in session but allows callback restart within 1 to 60 seconds (programmable). Control will answer on first ring during this time.
DTMF 99 TERMINATE SESSION - Ends the listen-in session.
DTMF 0 - [future use]
DTMF * CANCEL last key-press (undo)
DTMF # - [future use]

Operation of the two way listen-in feature is affected by the following installer programming options:

- Menu 05-Zone Definitions, Option 06 "Enable Listen-in" must be enabled "Yes" for any triggering zone(s).
- Menu 07-Global System Definitions:
Option G31 "2 Way Listen-in" must be enabled "Yes".
Option G32 "2 Way Callback Time" is a timer value which may be set to allow time for the CS to callback and initiate a listen-in session after dialer hangup.
Option G01 "TelRmtCtl" must be enabled "Yes" if you wish to initiate listen-in by Telephone Remote Control.

0112706

Two Way Listen-in Interface ELK-M1TWI

APPLICATION:

The **ELK-M1TWI** Interface allows microphones to be connected to the ELK-M1 for two way voice verification and listen-in. It features 3 separate microphone zones with up to 4 microphones per zone. Programming options and operation procedures are already built into the M1 control.

ELK
PRODUCTS, INC.

Two Way Listen-in Interface ELK-M1TWI



FEATURES:

- Interfaces Listen-in Microphones to the M1
- Powers Microphones and Performs Switching
- Provides 3 Separate Microphone Zones
- Each Zone Can Have Up to 4 Microphones
- All Programming and Operation Is Performed from the M1 Control

SPECIFICATIONS:

- Requires ELK-M1TWM or M1TWS Microphones
- Operating Voltage: 12 Volts D.C.
- M1TWI Board Current Draw: 10mA
- Microphone Current Draw: 5mA each
- Housing Dimensions: 4.375" x 3.0" x 1.125"
- Circuit Board Dimensions: 3.5" x 2.75"

NOTE: Use of Two Way Listen-in may be regulated local or state law and/or ordinance. It is the responsibility of the Installer to check before using this feature.

ELK
PRODUCTS, INC.

828-397-4200 Voice
828-397-4415 Fax
<http://www.elkproducts.com>
email: info@elkproducts.com

PO Box 100 • Hwy. 70W • Hildebran, NC 28637 • USA

Instructions Printed On Inside

INSTALLATION

The following equipment is required: ELK-M1TWI Interface, 8 Conductor J7 Cable (packed with M1TWI), 12 Conductor J16 Cable (packed with M1), and at least 1 M1TWS Speaker/Microphone or M1TWMMicrophone.

1. Mount the M1TWI in the M1 enclosure near the right side of the main board. The 12" audio/power cable must reach connector J7, located about 1/3 up from the lower right side of the M1 board. The M1TWI can be mounted using double sided tape or screws. An alternate method is to remove the board from the black case and mount it on a set of ELK-SWG Glides (not included) which holds the board vertically and conserves space.
2. Install at least one Microphone/Speaker (M1TWS) near the center of the building. Recommended wire is 22 to 24 gauge UTP (unshielded twisted pair) for the microphone, and 18 to 20 gauge for the speaker.
3. Connect the first microphone to the two terminals marked Zn 1. The M1TWI has 3 microphone zones (inputs) and 3 triggers. During a listen-in session the operator can choose to listen to ALL zones or select a specific zone. See operation instructions. Each zone is capable of handling up to 4 microphones.
4. Connect the microphone Zn 1 trigger terminal T1 to Output 7 (Tan wire) on the M1 J16 connector. Plug the J16 cable into the M1. **NOTE: Outputs 7, 8, and 9 automatically become assigned as the triggers for Microphone zones 1, 2, and 3 whenever the "Two Way Listen-in" option is enabled in the M1 Installer Programming. See Menu 07-Global System Definitions, option 31.**
5. Connect speaker wires directly to Output 1 on the M1. **NOTE: The maximum number of speakers is based on the total load (resistance/impedance). Output 1 should never be loaded below 2 Ohms total load. Typically that allows up to four 8 Ohm speakers to be paralleled.**
6. Connect the Aud, +, and - terminals to the Brown/White, White/Blue, and Blue/White wires of the 8 conductor J7 Cable. Plug the J7 cable into the M1 connector marked J7 "Audio Network Interface". The M1TWI is now powered up and ready to test.

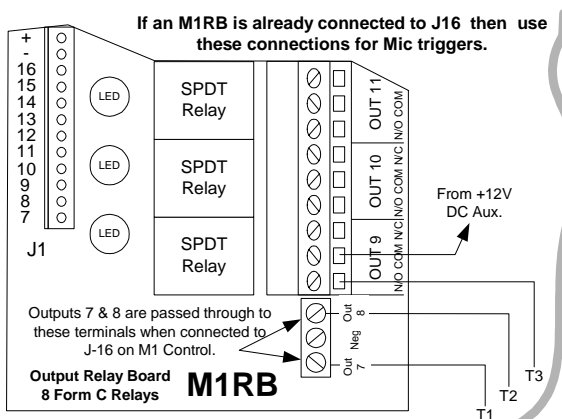

IMPORTANT NOTE:
Use of Two Way Listen-in may be regulated local or state law and/or ordinance. It is the responsibility of the Installer to check before using this feature.

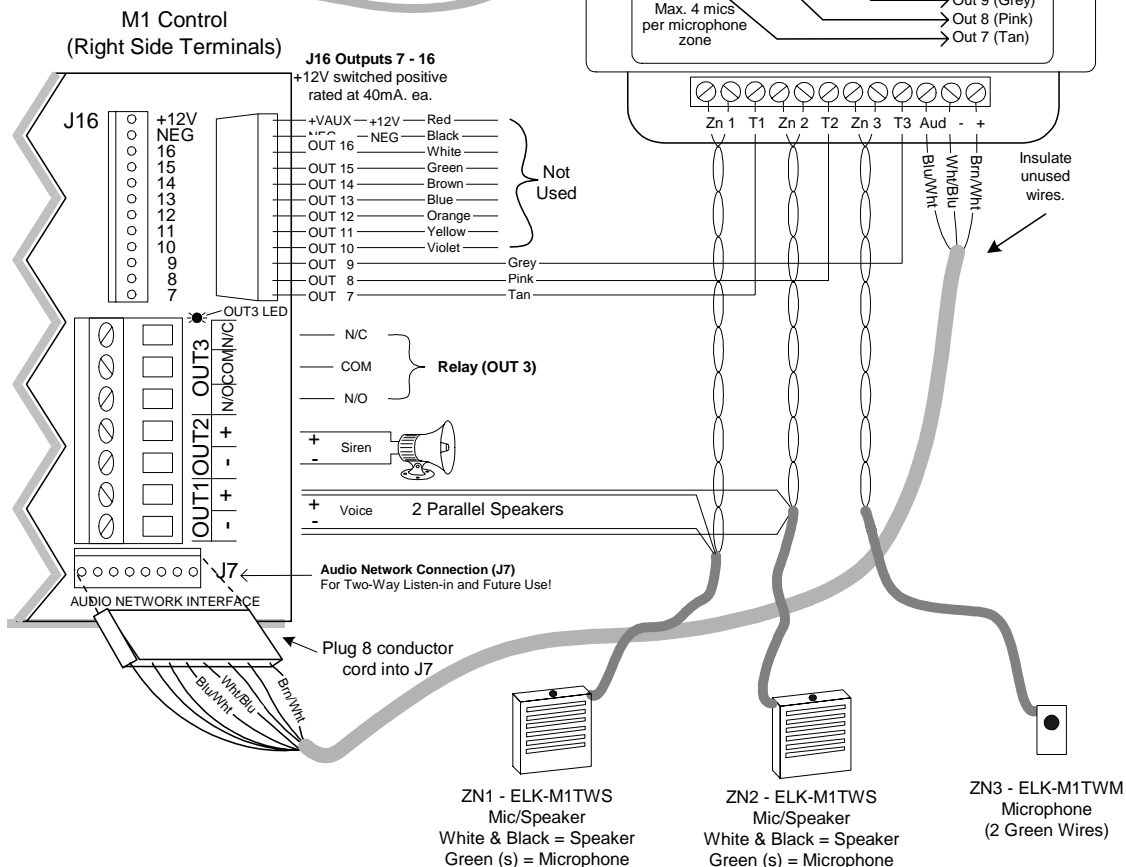
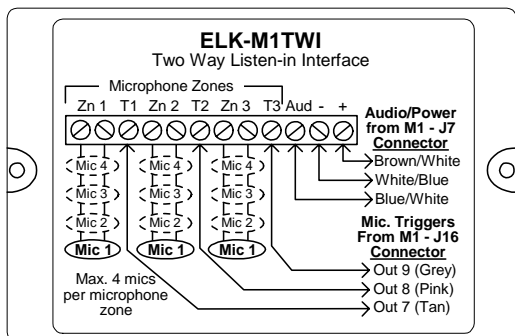

Hookup Diagram for ELK-TWI Listen-in with 2 Mic/Speaker Zones and 1 Microphone only Zone