

STI Fire Series Stopper® Station



SS-2000F



SS-2002F

PRODUCT OVERVIEW

This STI Stopper Station with a patented design is a highly advanced push button unit that is ADA Compliant and UL Listed to U.S. and Canadian safety standards. Model SS-2000F is designed specifically to complement fire alarm systems of the 21st century. Operation includes Push-to-Activate and Key-to-Reset. The unit incorporates quality features throughout, including raised lettering molded into its polycarbonate housing.

If you wish, you can protect your fire Stopper Station with a super tough STI cover to help stop vandalism or accidental damage. The Mini Stopper® II cover can be ordered with an optional pre-alarm to help stop malicious activation for inside applications. Outside applications require a Mini Weather Stopper® to be mounted over the Stopper Station button to maintain UL Approval.

FEATURES

- ADA Compliant and UL Listed to U.S. and Canadian safety standards for outdoor and indoor use.
- Stainless steel backplate with ground lug.
- SS-2000F has two replaceable N.O., SPST gold-plated contact blocks rated for 1 amp @ 250 VDC.
- SS-2002F has two Form "C" contacts rated 125/250 VAC, 10A, 1/2 HP, 30 VDC, 6A.
- Polycarbonate complies with FDA regulations for food contact applications.
- Typical working properties of polycarbonate are -40° to 250°F (-40° to 121°C).
- Add a tough STI cover to protect against vandalism, accidental damage or weather.
- When using an STI Stopper Station outdoors, UL requires unit to be protected with an STI UL Listed Weather Stopper®.
- Patented design helps stop accidental activation.
- Super tough housing.
- Cover available for indoor use, with a built-in alarm to help stop malicious activation.
- Simple Push-to-Activate and Key-to-Reset operation.
- Raised letters and symbols molded into housing.
- Three year guarantee against breakage of polycarbonate in normal use (one year on electro mechanical and electronic components).

STI Fire Series Stopper® Station

Dimensions and Technical Information

MODELS AVAILABLE

- SS-200* F Red button Push-to-Activate Key-to-Reset
- SS-201* F Button with Bopper Stopper® cover
- SS-203* F Button with Mini Stopper® II cover with no horn - flush mount
- SS-204* F Button with Mini Stopper II cover with horn - flush mount
- SS-205* F Button with Mini Weather Stopper® cover - flush mount
- SS-206* F Button with Mini Weather Stopper cover - surface mount
- SS-207* F Button with Mini Stopper II cover without horn with spacer
- SS-208* F Button with Mini Stopper II cover with horn with spacer

* **NOTE:** Last digit of part number choose:
 "0" for Push, Key-To-Reset (Octagon)
 "2" for Push, Key-To-Reset (Mushroom)
 For complete cover information, see spec sheet on the specific cover

Accessories

- SUB-102722-R Plastic Spacer - red for SS-2000F
- 19030 One extra key for 2000F model
- 18061 One extra key for 2002F model
- 10196 N.O. contact for 2000F model
- 10197H Contact holder for "0" button only
- 10198 N.C. contact for 2000F model
- SUB-71100A-R Backbox - red for SS-2002F (included)

APPROVALS & WARRANTY

TESTING

- It has been tested and approved or listed by:
- Underwriter Laboratories File No. S2466
 - Canadian Underwriter Laboratories Issue File No. S2466
 - California State Fire Marshal approval 7150-1416:102
 - ADA Compliant

NOTE

Please note that it is mandated by UL that your STI Stopper Station be protected with an STI UL Listed Weather Stopper® or Mini Weather Stopper® cover when used outdoors.

WARRANTY

Three year guarantee against breakage of polycarbonate in normal use (one year on electro mechanical and electronic components).

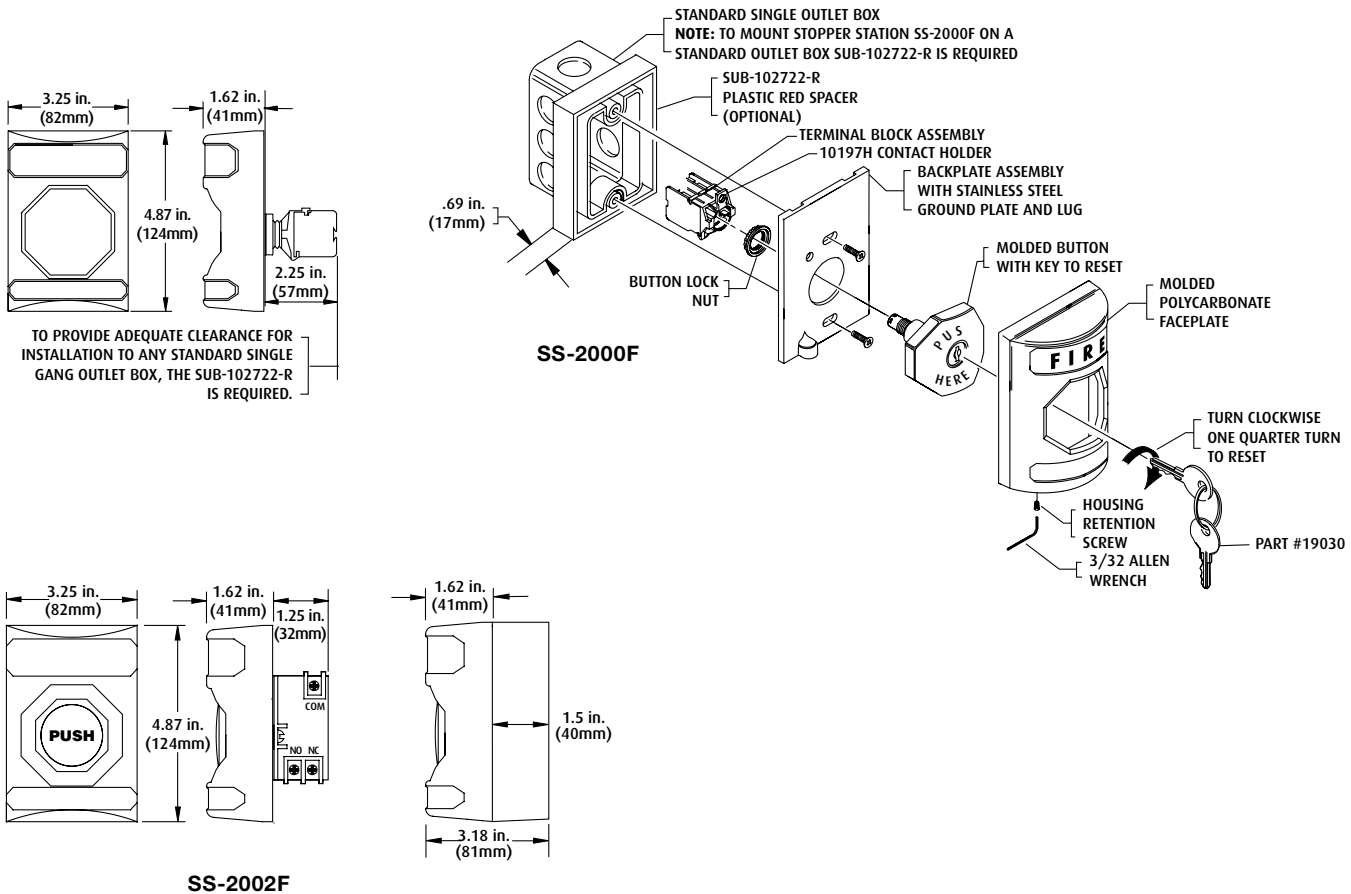

Safety Technology International, Inc.

2306 Airport Road
 Waterford, Michigan
 48327, USA

Tel: 248-673-9898
 Fax: 248-673-1246
 Tollfree: 800-888-4784
 info@sti-usa.com
 www.sti-usa.com

Unit 49G Pipers Road
 Park Farm Industrial Estate
 Redditch, Worcestershire
 B98 0HU England

Tel: 44 (0) 1527 520 999
 Fax: 44 (0) 1527 501 999
 Free: 0800 085 1678 (UK)
 www.sti-europe.com