

Smoke Strobe Lens

NOTICE: This manual should be left with the owner/user of this equipment.

General Information

The National Fire Protection Association has published codes, standards, and recommended practices for the installation and use of this product. It is recommended that the installer be familiar with these requirements, with local codes, and any special requirements of the local authority having jurisdiction.

This SMOKE strobe lens is designed to replace the FIRE lens used with the PS12 and PS24 strobes.

NOTE: To install the SMOKE lens, a PS12 or PS24 strobe accessory must be purchased separately.

Mounting

Remove the two screws on the back of the PS12 or PS24 assembly (see Figure 2). The FIRE lens can now be removed. Reverse this procedure to install the SMOKE lens.

Please follow the installation instructions (I56-305-07) included with the PS12 and PS24 accessory to complete the installation.

Model Numbers

SMOKE lens, wall mount	PS12/24-LENS-SW
SMOKE lens, ceiling mount	PS12/24-LENS-SC

Figure 1. SMOKE lens:

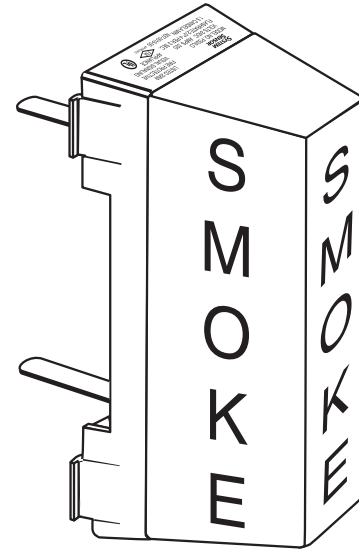
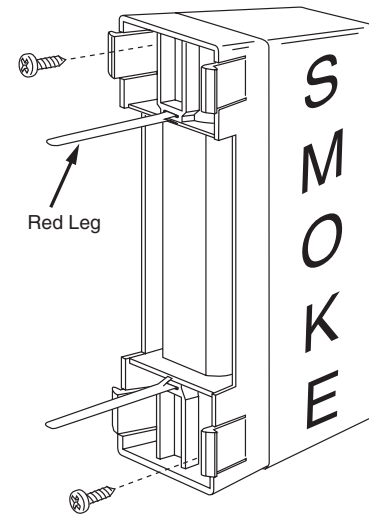

Figure 2. Remove the rear screws:



Three-Year Limited Warranty

System Sensor warrants its enclosed SMOKE lens to be free from defects in materials and workmanship under normal use and service for a period of three years from date of manufacture. System Sensor makes no other express warranty for this SMOKE lens. No agent, representative, dealer, or employee of the Company has the authority to increase or alter the obligations or limitations of this Warranty. The Company's obligation of this Warranty shall be limited to the repair or replacement of any part of the SMOKE lens which is found to be defective in materials or workmanship under normal use and service during the three year period commencing with the date of manufacture. After phoning System Sensor's toll free number 800-SENSOR2 (736-7672) for a Return Authorization number, send defective units postage prepaid to: System Sensor, Returns

Department, RA # _____, 3825 Ohio Avenue, St. Charles, IL 60174. Please include a note describing the malfunction and suspected cause of failure. The Company shall not be obligated to repair or replace units which are found to be defective because of damage, unreasonable use, modifications, or alterations occurring after the date of manufacture. In no case shall the Company be liable for any consequential or incidental damages for breach of this or any other Warranty, expressed or implied whatsoever, even if the loss or damage is caused by the Company's negligence or fault. Some states do not allow the exclusion or limitation of incidental or consequential damages, so the above limitation or exclusion may not apply to you. This Warranty gives you specific legal rights, and you may also have other rights which vary from state to state.