



Sync•Circuit™ Module

The Sync•Circuit module synchronizes SpectrAlert® Advance strobes at 1 Hz and horns and chimes at temporal 3 over a single pair of wires. Patented module technology also allows the silencing of horns or chimes on horn/strobe and chime/strobe models over a pair of wires.



Features

- Two-wire operation from module to the devices
- Silences horns and chimes over a two-wire loop
- Synchronizes strobes at 1 Hz
- Synchronizes horns and chimes to temporal 3 pattern
- Patented technology
- Interconnects modules for multiple zone synchronization
- Module controls two Style Y (Class B) circuits or one Style Z (Class A) circuit
- New NAC slave feature enables the interconnection of slave modules over a supervised NAC loop

The MDL3 Module is designed to work with the SpectrAlert and SpectrAlert Advance series of notification appliances to provide a means of synchronizing the temporal-coded horns and chimes, synchronizing the one-second flash timing of the strobe, and silencing the horns and chimes of the horn/strobe and chime/strobes combination over a two-wire circuit while leaving the strobes active.

Application Flexibility. The Sync•Circuit module is designed to power and synchronize either two 3-amp circuits wired in Class B, or one 3-amp circuit powered as Class A. Should more than two zones require synchronization, additional modules can be added by interconnecting the “slave” input and output terminals between modules.

Agency Listings



Sync-Circuit™ Module Specifications

Architectural/Engineering Specifications

Synchronization Circuit Module shall be a System Sensor Sync-Circuit Model _____ listed to UL 464 and UL 1971 and shall be approved for fire protective service. The module shall synchronize SpectrAlert® or SpectrAlert Advance strobes at 1 Hz and horns at temporal 3. Also, the module shall be capable of silencing the horns on horn/strobe models, while operating the strobes, over a single pair of wires. The module shall be capable of mounting to a 4 1/16" x 4 1/16" x 2 1/8" back box and shall control two Style Y (class B) or one Style Z (class A) circuit. The module shall be capable of multiple zone synchronization by connecting multiple modules (slaves) together. Slaves can be driven from either the slave output of a prior MDL3 or from the NAC output of the master. Using the NAC enables all wiring to be supervised, whereas the slave-out terminals are not supervised, so their use is confined to specific applications.

Note: The module shall not operate on a coded power supply.

Physical Specifications

Dimensions	5 1/4" L x 5 1/4" W
Mounting	4 1/16" x 4 1/16" x 2 1/8" back box
Indoor Operating Temperature	32° to 120° F (0° to 49° C)
Electrical/Operating Specifications	
Operating Voltage	12 or 24 VDC and FWR unfiltered
Operating Voltage Range (12 V)	8.5 to 17.5 VDC
Operating Voltage Range (24 V)	16.5 to 33 VDC
Maximum Load on Loop	3 Amps/zone
U.S. Patent Nos.	5,598,139 5,850,178

Horns and Chimes Silenced Over Two-Wire Circuit

- Any mix of Horn/Strobes, Chime/Strobes or Strobe-only devices is acceptable
- Horn and chime control connects to interruptible power source

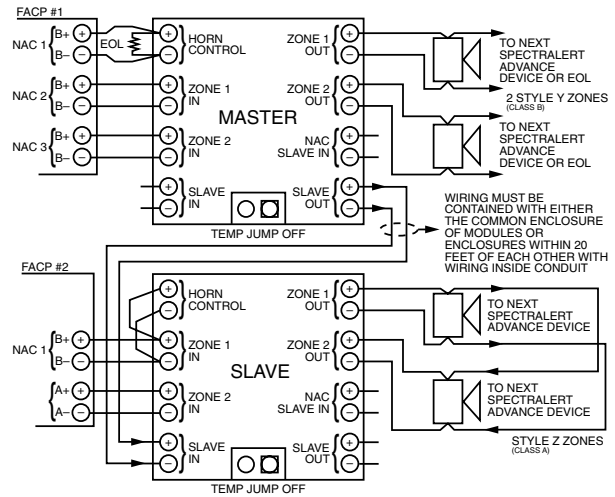

Master-Slave Mode

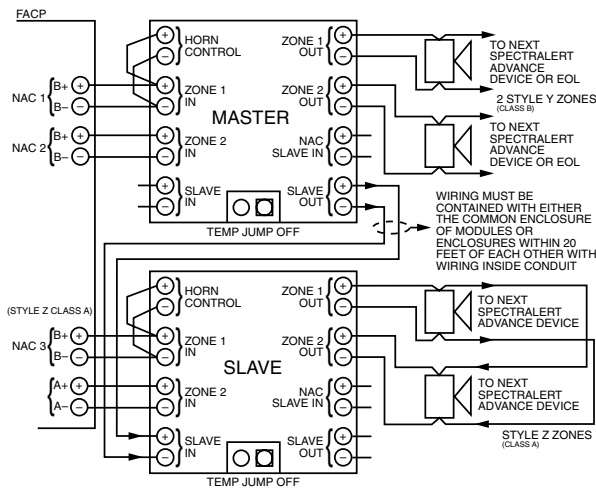

Master-Slave Using NAC-Slave Input

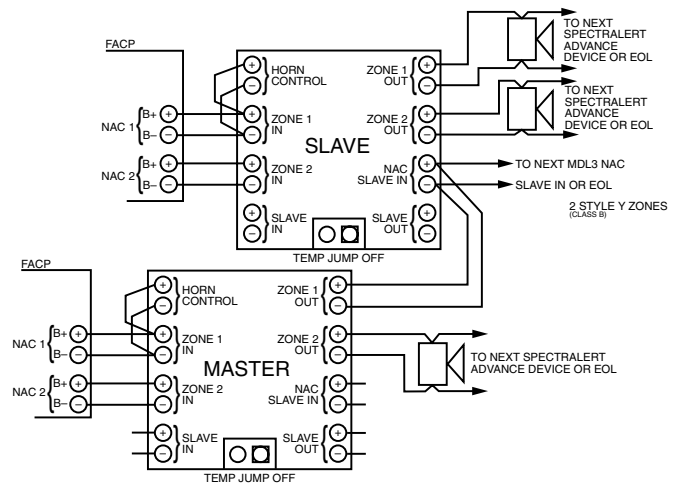

Current Draw and Ordering Information

Red	White	Voltage	Average Current (mA)		Peak Current (mA)		In-rush Current (mA)		NAC Slave Input (mA)	
			DC	FWR	DC	FWR	DC	FWR	DC	FWR
MDL3R,	MDL3W,	12	10	12	50	60	100	120	3.5	4
MDL3RA (Canadian)	MDL3WA (Canadian)	24	12	15	60	75	120	150	4.5	5



3825 Ohio Avenue • St. Charles, IL 60174
Phone: 800-SENSOR2 • Fax: 630-377-6495

©2009 System Sensor.
Product specifications subject to change without notice. Visit systemsensor.com for current product information, including the latest version of this data sheet.
A05-1007-005 • 2/09 • #2030